

Pb-free
HEAT



EBW1444US-E

High Flux , Power LED

Features

Package	High Heat Radiation Ceramic LCC Type with Metallic Reflector Diffused Pale Yellow Resin
Product feature	<ul style="list-style-type: none">• Outer Dimension 8.67 x 5.27 x 1.6mm (L x W x H)• Temperature range Storage Temperature : -40°C~120°C Operating Temperature : -40°C~100°C• Lead-free soldering compatible• RoHS compliant
Chromaticity coordinates	x = 0.356 TYP., y = 0.370 TYP. (Condition : IF=350mA)
Spatial distribution	120 deg.
Die materials	InGaN
Rank grouping parameter	Sorted by luminous intensity and chromaticity per rank tray
Assembly method	Auto pick & place machine (Auto Mounter)
Soldering methods	Recommendation of Reflow soldering
Packing form	100pcs per tray in a 32 x 111mm . 2~11 trays are contained into 1 moisture-proof bag. (Standard)
ESD	2kV (HBM)

Recommended Applications

- Residential lighting, Office lighting, Plant lighting, Store lighting, and Special lighting etc.

EBW1444US-E

High Flux , Power LED

Color , Luminous Flux

(Ta=25°C,IF=350mA)

Part No.	Emitted Color	Lens Color	CCT TYP.	Chromaticity Coordinates TYP.		Luminous Flux ϕ_v (lm)	
				x	y	MIN.	TYP.
				EBW1444US-E	Daylight	Pale Yellow	4,800K

Absolute Maximum Ratings

(Ta=25°C)

Item	Symbol	Ratings	Unit
Power Dissipation	P_d	8,000	mW
Continuous Forward Current	I_F	500	mA
Repetitive Peak Forward Current ※1	I_{FRM}	1250	mA
Allowable Reverse Current	I_R	85	mA
ESD(HBM)※2	ESD	2,000	V
Solder Temperature ※3 (Reflow soldering)	T_{sld}	260	°C
Operating Temperature※4	T_{opr}	-40~+100	°C
Storage Temperature※4	T_{stg}	-40~+120	°C

 ※1 I_{FRM} Measurement condition / Pulse Width \leq 1ms., Duty \leq 1/20

 ※2 ESD testing method : EIAJ 4701/300(304) (HBM) 1.5k Ω , 100pF

※3 Please refer to the attached sheets soldering conditions.

※4 The range of operating and storage temperature is not tray condition.

Thermal Characteristics

(Ta=25°C)

Item	Symbol	Ratings TYP.	Unit
Thermal Resistance (Junction/Solder Point)	$R_{th(j-s)}$	2.5	°C/W
Junction Temperature	T_j	125	°C

Electro-Optical Characteristics

(Ta=25°C)

Item	Condition	Symbol	Characteristics		
Forward Voltage	I _F =350mA	V _F	MIN.	11.6	V
			TYP.	13.0	
			MAX.	14.8	
Reverse Voltage	I _R =85mA	V _R	MIN.	0.8	V
			MAX.	1.7	
Half Intensity Angle	I _F =350mA	Δ θ _x	TYP.	120	deg.
		Δ θ _y			
Chromaticity Coordinates	I _F =350mA	x	TYP.	0.356	-
		y	TYP.	0.370	-

Sorting chart for Forward Voltage Characteristics

(Ta=25°C)

Rank	VF(V)		Condition
	MIN.	MAX.	
1	11.6	13.6	I _F =350mA
2	13.6	14.8	

Tolerance Each Rank : +/- 0.1V

※LEDs shall be "Forward Voltage" sorted put into the following chart and each rank parts shall be packed separately when shipping.

Luminous Flux Rank (Unit : lm)

(Ta=25°C)

Rank	Φ_v (lm)		Condition
	MIN.	MAX.	
C6	300	330	IF=350mA
C7	330	390	

Tolerance Each Rank : +/-10%

※LEDs shall be "Luminous Flux" sorted put into the following chart and each rank parts shall be packed separately when shipping.

Sorting Chart for Chromaticity Coordinates

(Ta=25°C)

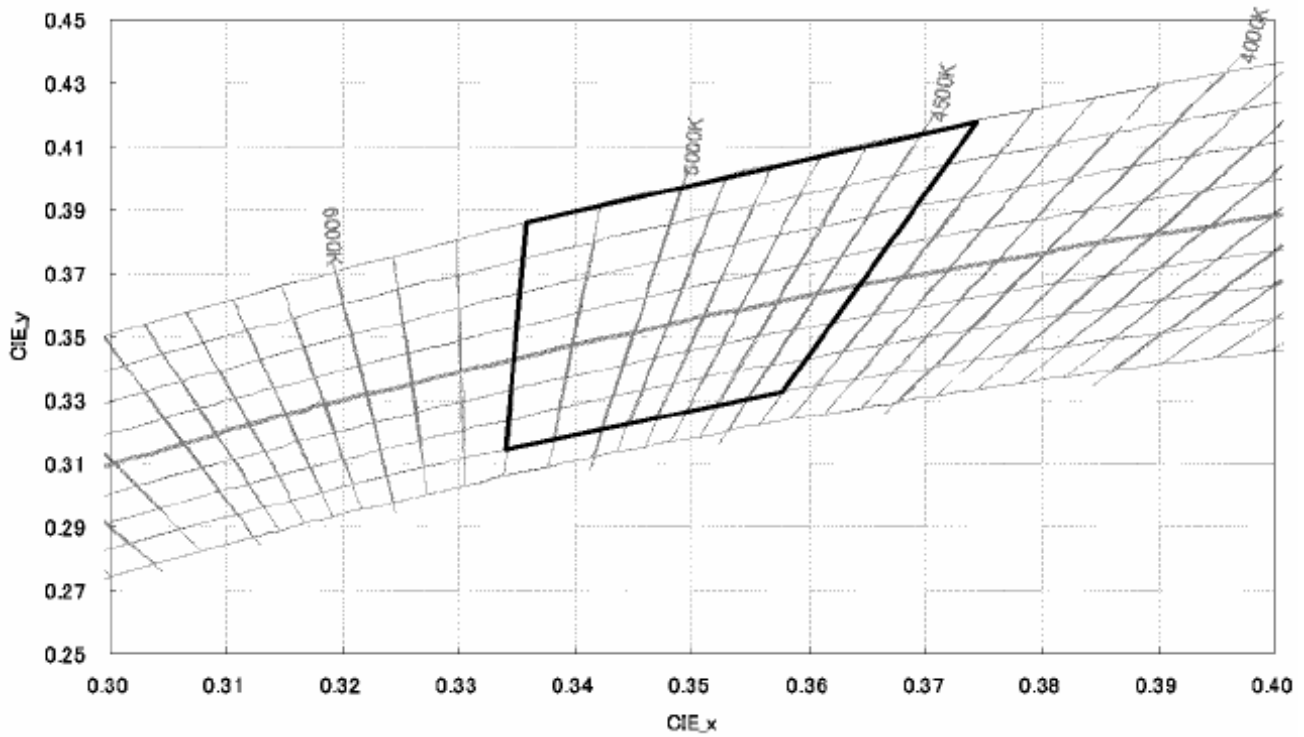

Tolerance Each Rank : +/-0.02

LEFT DOWN point		LEFT UP point		RIGHT UP point		RIGHT DOWN point	
x	y	x	y	x	y	x	y
0.3340	0.3147	0.3357	0.3860	0.3744	0.4180	0.3577	0.3324

Technical Data

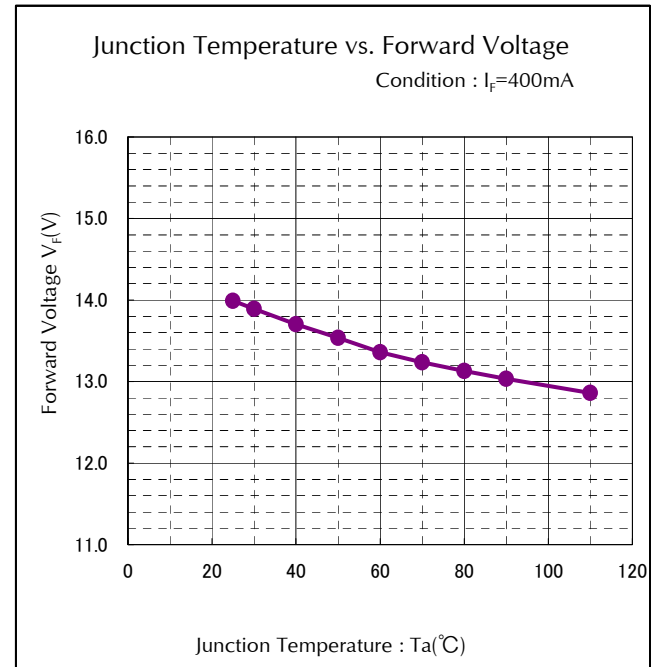
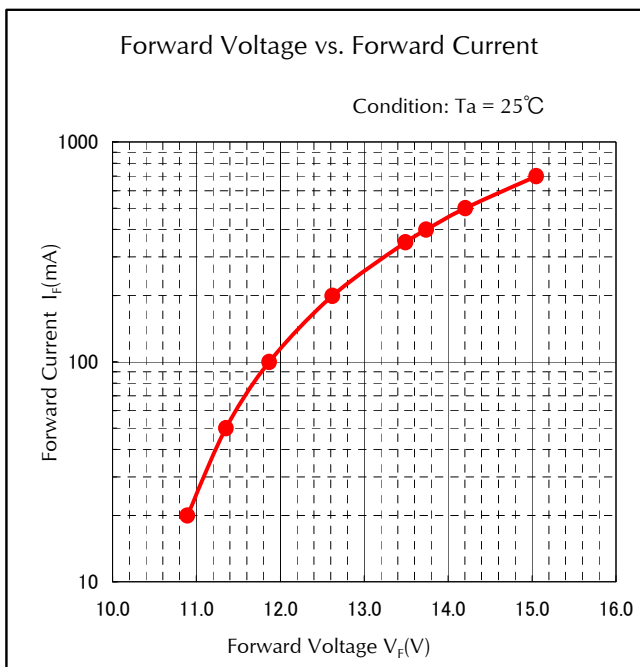
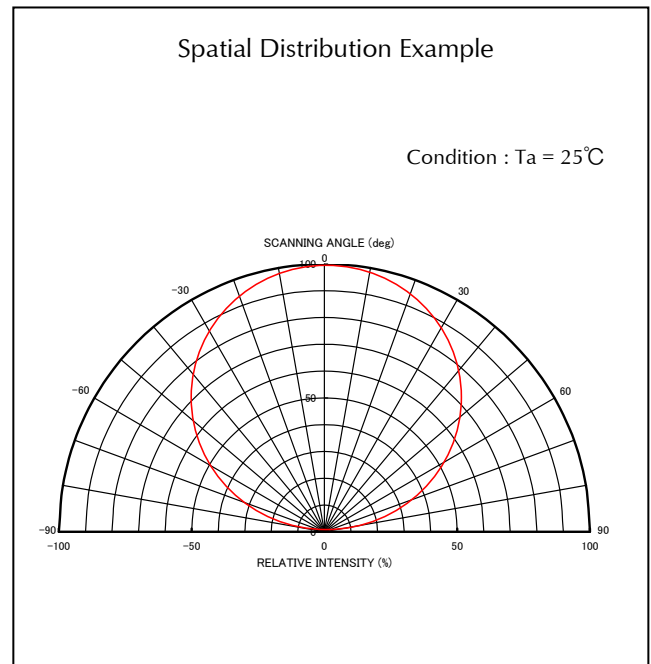
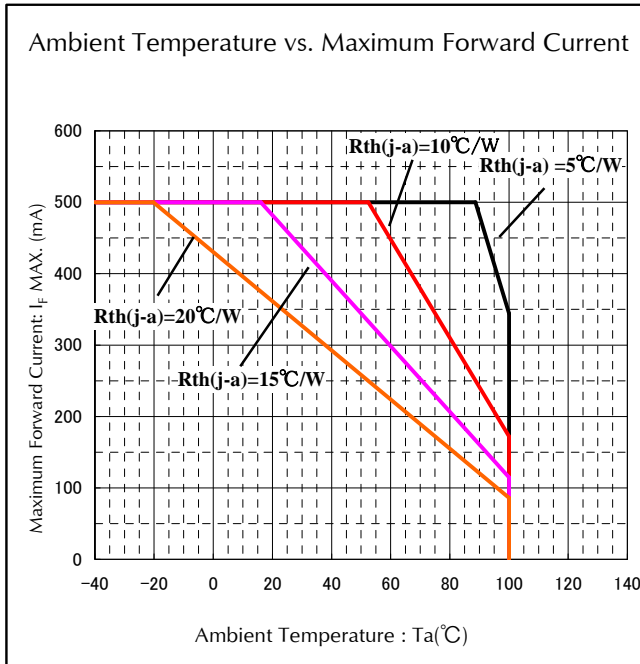

Technical Data

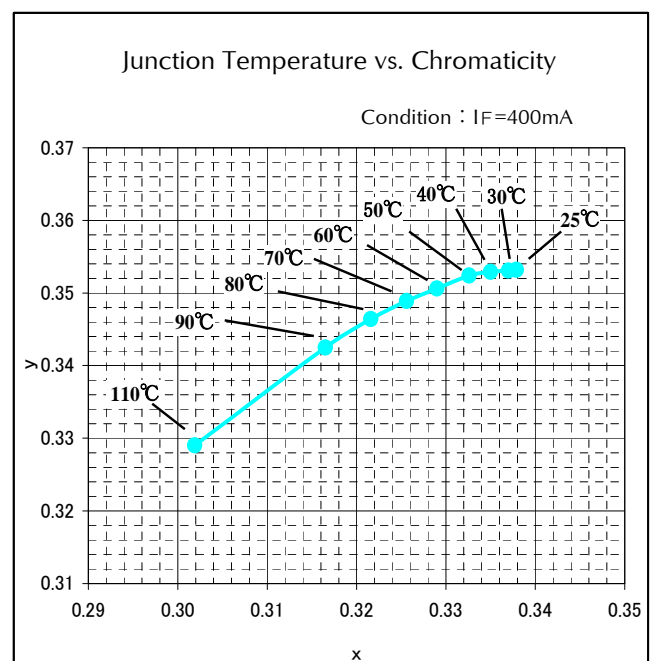
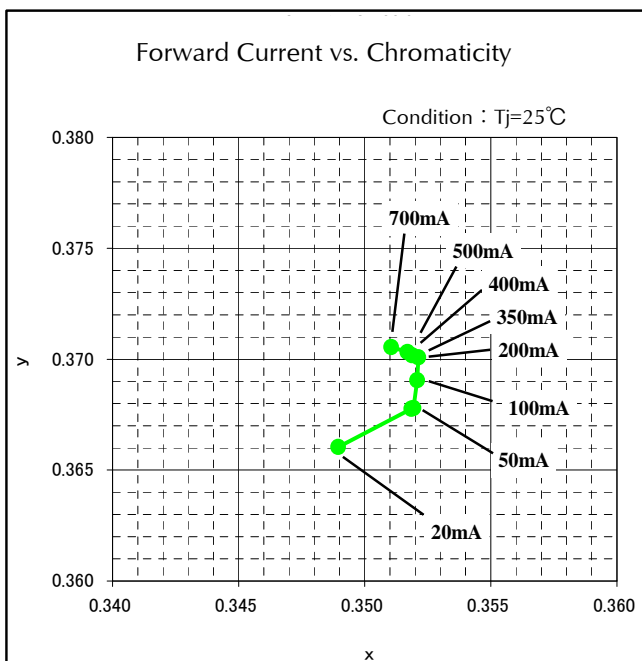
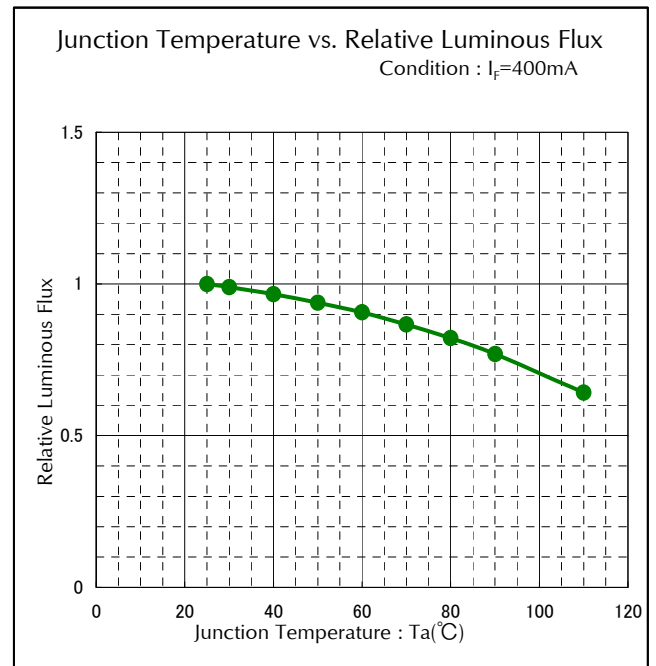
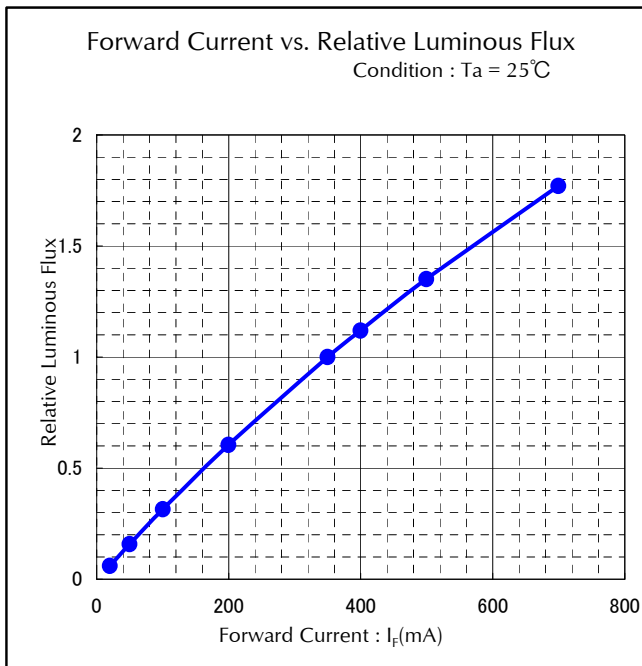

Technical Data

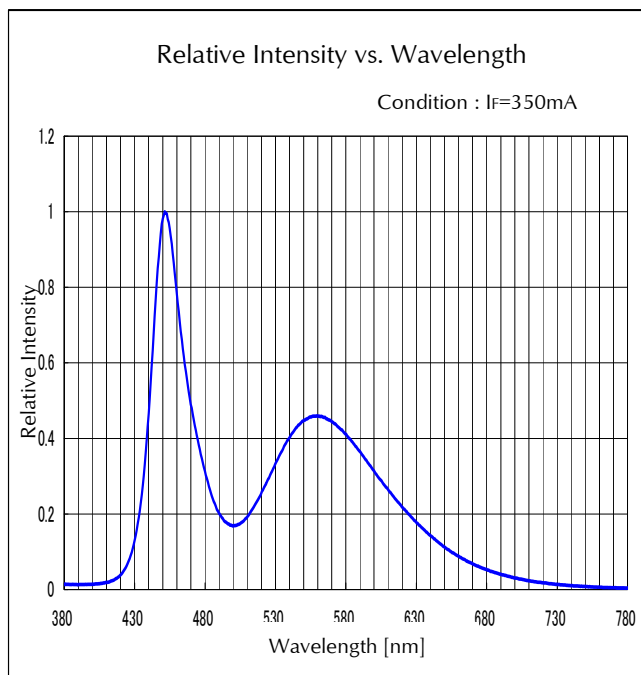

Package Dimensions

(Unit : mm)

MASS : (175.0)mg

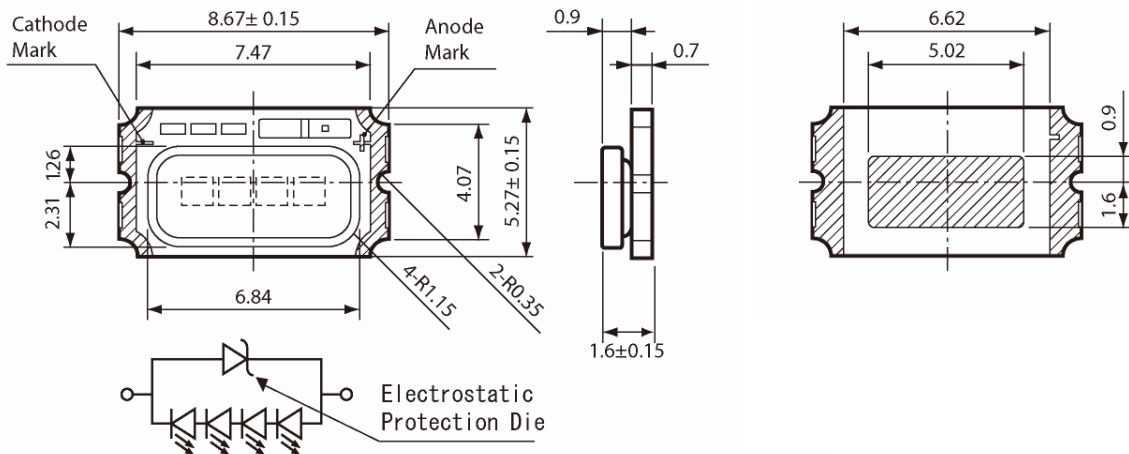

Recommended Soldering Pattern

(Unit : mm)

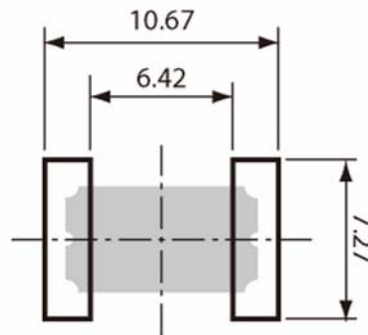

Pocket Dimensions

(Unit : mm)

※ Quantity: 100pcs/ tray

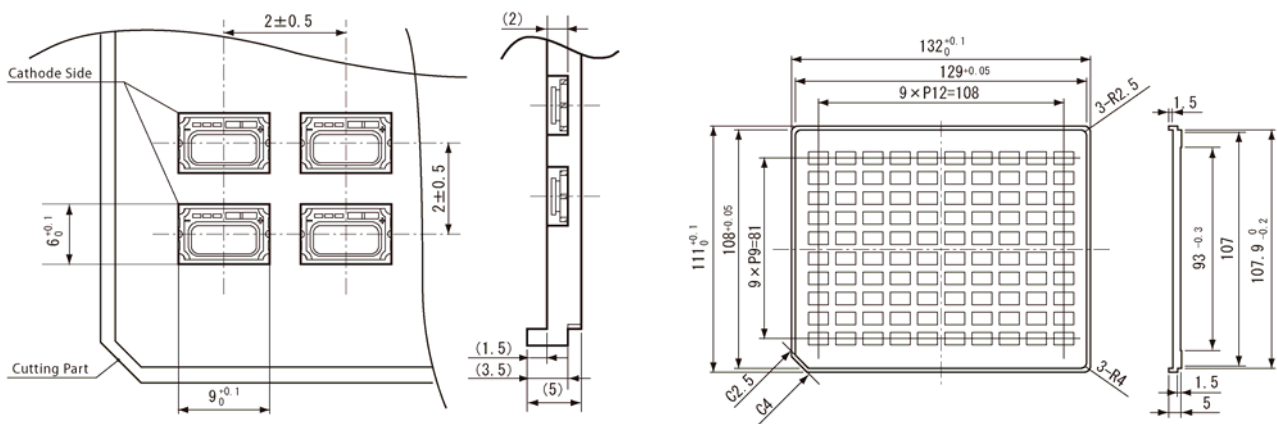

Reflow Soldering Conditions

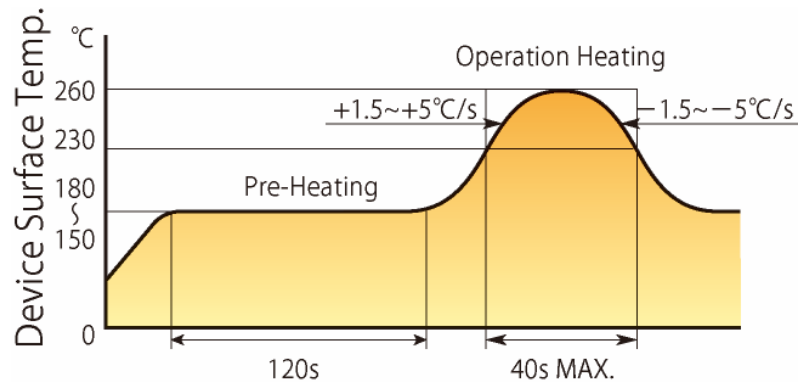

- 1) The above profile temperature gives the maximum temperature of the LED resin surface. Please set the temperature so as to avoid exceeding this range.
- 2) Total times of reflow soldering process shall be no more than 2 times. When the second reflow soldering process is performed, intervals between the first and second reflow should be short as possible (while allowing some time for the component to return to room temperature after the first reflow) in order to prevent the LED resin from absorbing moisture.

Reliability Testing Result

Reliability Testing Result	Applicable Standard	Testing Conditions	Duration	Failure
Room Temp. Operating Life	EIAJ ED-4701/100(101)	Ta = 25°C, If = Maximum Rated Current	1,000 h	0/20
High Temp. Operating Life	EIAJ ED-4701/100(101)	Ta = Maximum Rated Operating Temp., If = 350mA	1,000 h	0/20
Low Temp. Operating Life	EIAJ ED-4701/100(101)	Ta = -40°C, If = Maximum Rated Current	1,000 h	0/20
Wet High Temp. Operating Life	EIAJ ED-4701/100(102)	Ta = 60°C, 90%, If = 350mA	1,000 h	0/20
Temperature Cycling	EIAJ ED-4701/100(105)	Ta = -40°C ~ Maximum Rated Storage Temp. (each 15min.)	1,000 cycles	0/20
Resistance to Soldering Heat	EIAJ ED-4701/300(301)	Preheating : 150 ~ 180°C(120s Max.) Operation Heating : 260°C	2 times	0/20

Failure Criteria

Items	Symbols	Conditions	Failure criteria
Luminous Intensity	Iv	If=100mA	Testing Min. Value < Spec. Min. Value x 0.5
Forward Voltage	Vf	If=100mA	Testing Max. Value ≥ Spec. Max. Value x 1.2
Cosmetic Appearance	-	-	Occurrence of notable decoloration, deformation and cracking

Special Notice to Customers Using the Products and Technical Information Shown in This Data Sheet

- 1) The technical information shown in the data sheets are limited to the typical characteristics and circuit examples of the referenced products. It does not constitute the warranting of industrial property nor the granting of any license.
- 2) For the purpose of product improvement, the specifications, characteristics and technical data described in the data sheets are subject to change without prior notice. Therefore it is recommended that the most updated specifications be used in your design.
- 3) When using the products described in the data sheets, please adhere to the maximum ratings for operating voltage, heat dissipation characteristics, and other precautions for use. We are not responsible for any damage which may occur if these specifications are exceeded.
- 4) The products that have been described to this catalog are manufactured so that they will be used for the electrical instrument of the benchmark (OA equipment, telecommunications equipment, AV machine, home appliance and measuring instrument).
The application of aircrafts, space borne application, transportation equipment, medical equipment and nuclear power control equipment, etc. needs a high reliability and safety, and the breakdown and the wrong operation might influence the life or the human body. Please consult us beforehand if you plan to use our product for the usages of aircrafts, space borne application, transportation equipment, medical equipment and nuclear power control equipment, etc. except OA equipment, telecommunications equipment, AV machine, home appliance and measuring instrument.
- 5) In order to export the products or technologies described in this data sheet which are under the "Foreign Exchange and Foreign Trade Control Law," it is necessary to first obtain an export permit from the Japanese government.
- 6) No part of this data sheet may be reprinted or reproduced without prior written permission from Stanley Electric Co., Ltd.
- 7) The most updated edition of this data sheet can be obtained from the address below:
<http://www.stanley-components.com>