Standard Read/Write ID Transponder with Anti-collision

DATASHEET

Features

- Read/write anti-collision ID transponder in plastic package
- Contactless read/write data transmission
- Inductive coupled power supply at 125kHz
- Basic component: R/W Atmel® IDIC® e5551
- Anti-collision mode by password request
 - E.g. 10 transponders read out in < 500ms (RF/32, Maxblock 2) depending on the application
- Built-in coil and capacitor for circuit antenna
- Starts with cyclical data read out
- 224-bit EEPROM user programmable in 32-bit blocks
- Typically < 50ms to write and verify a block
- Write protection by lock bits
- Malprogramming protection
- Options set by EEPROM
 - Bit rate [bit/s]: RF/8, RF/16, RF/32, RF/40, RF/50, RF/64, RF/100, RF/128
 - Modulation: BIN, FSK, PSK, Manchester, bi-phase

Application

- Access control systems
- Brand protection
- Process control and automation systems
- Installation and medical equipment
- Asset management systems
- Industrial

1. Description

The Atmel® ATA5551M-PPMY is a completely programmable R/W transponder which implements all important functions for identification systems, including anti-collision (e.g., 10 transponders in < 500ms depending on the application). It allows the contactless reading and writing of data which are transmitted bi-directionally between a read/write base station and the transponder. It is a plastic-packaged device which accommodates the IDIC e5551 and also the antenna realized as an LC-circuit. No additional external power supply is necessary for the transponder because it receives power from the RF field generated by the base station. Data are transmitted by modulating the amplitude of the RF field. The Atmel ATA5551M-PPMY can be used to adjust and modify the ID code or any other stored data, e.g., rolling code systems. The on-chip 264-bit EEPROM (8 blocks, 33 bits per block) can be read and written block wise from the base station. The blocks can be protected against overwriting. One block is reserved for setting the operation modes of the IC. Another block can obtain a password to prevent unauthorized writing.

Figure 1-1. System Block Diagram

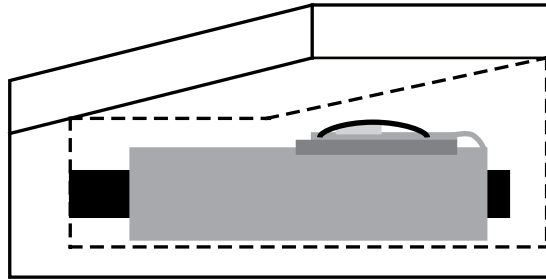

2. General

The transponder is the mobile part of the closed coupled identification system (see [Figure 4-1 on page 3](#)), whereas the reader (writer) is based on an IC or on discrete solutions, and the read/write transponder is based on the Atmel IDIC e5551.

The transponder is a plastic cube device consisting of the following parts:

- The transponder antenna, realized as a tuned LC circuit
- Read/write Atmel IDIC (e5551) with EEPROM

3. Transponder Antenna

The antenna consists of a coil and a capacitor for tuning the circuit to the nominal carrier frequency of 125kHz. The coil has a ferrite core for improving the distance of read, write and programming operations.

4. Read/Write IDIC e5551

The read/write Atmel IDIC e5551 is part of the transponder Atmel ATA5551M-PPMY. The data are transmitted bidirectionally between the base station and the transponder. The transponder receives power via a single coil from the RF signal generated by the base station. The single coil is connected to the chip and also serves as the IC's bi-directional communication interface.

Data are transmitted by modulating the amplitude of the RF signal. Reading of register contents occurs by damping the coil by an internal load. Writing into registers occurs by interrupting the RF field in a specific way. The Atmel ATA5551M-PPMY transponder operates at a nominal frequency of 125kHz. There are different bit rates and encoding schemes.

The on-chip 264-bit EEPROM (8 block, 33 bits each) can be read and written block wise from the base station. The blocks can be protected against overwriting by using lock bits. One block is reserved for setting the operation modes of the IC. Another block contains a password to prevent unauthorized writing.

4.1 Features

- Low-power, low-voltage operation
- Contactless power supply
- Contactless read/write data transmission
- Radio frequency (RF): 100kHz to 150kHz
- 264 bit EEPROM memory in 8 blocks of 33 bits
- 224 bits in 7 blocks of 32 bits are free for user data
- Block write protection
- Extensive protection against contactless malprogramming of the EEPROM
- Anticollision using answer-on-request (AOR)
- Typical < 50ms to write and verify a block
- Other options set by EEPROM:
 - Bitrate [bit/s]: RF/8, RF/16, RF/32, RF/40, RF/50, RF/64, RF/100, RF/128
 - Modulation: BIN, FSK, PSK, Manchester, bi-phase
 - Other: Terminator mode, password mode

Figure 4-1. RFID System using e5551 Tag

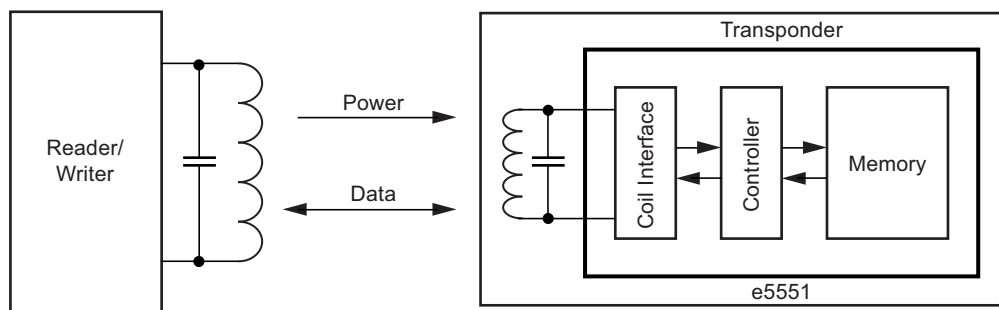

4.2 Atmel e5551 Building Blocks

4.2.1 Analog Front End (AFE)

The AFE includes all circuits which are directly connected to the coil. It generates the IC's power supply and handles the bidirectional data communication with the reader unit. It consists of the following blocks:

- Rectifier to generate a dc supply voltage from the ac coil voltage
- Clock extractor
- Switchable load between Coil1/ Coil2 for data transmission from the IC to the reader unit (read)
- Field gap detector for data transmission from the reader unit into the IC (write)

4.2.2 Controller

The main controller has following functions:

- Load mode register with configuration data from EEPROM block 0 after power-on and also during reading
- Control memory access (read, write)
- Handle write data transmission and the write error modes
- The first two bits of the write data stream are the OPcode. There are two valid OP-codes (standard and stop) which are decoded by the controller.
- In password mode, the 32 bits received after the OPcode are compared with the stored password in block 7.

4.2.3 Bitrate Generator

The bitrate generator can deliver the following bitrates: RF/8 - RF/16 - RF/32 - RF/40 - RF/50 - RF/64 - RF/100 - RF/128

4.2.4 Write Decoder

Decode the detected gaps during writing. Check if write data stream is valid.

4.2.5 Test Logic

Test circuitry allows rapid programming and verification of the IC during test.

4.2.6 HV Generator

Voltage pump which generates $\approx 18V$ for programming of the EEPROM.

4.2.7 Pad Layout

Figure 4-2. Pad Layout

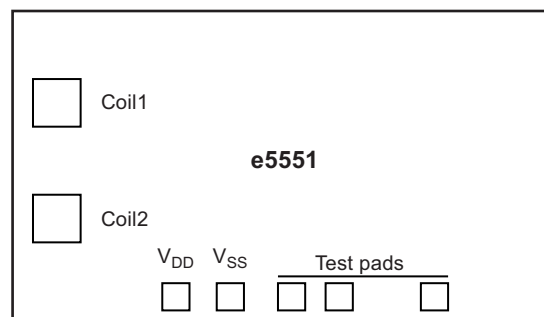
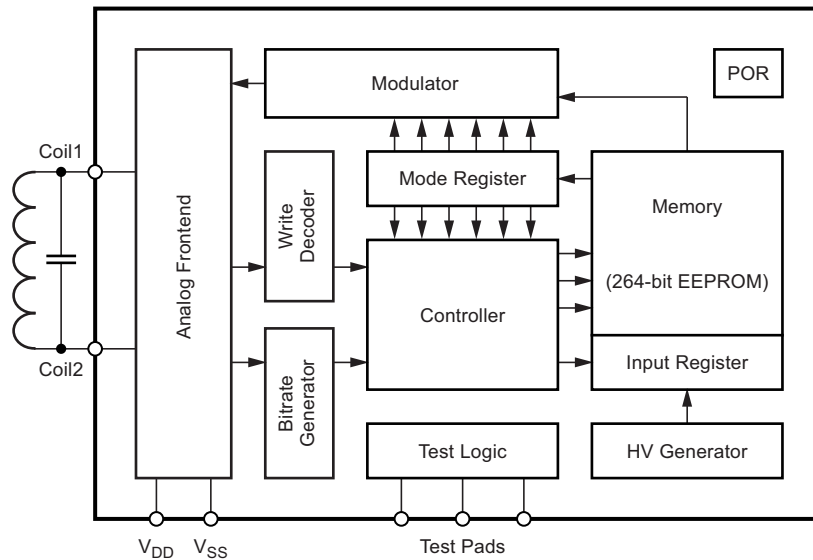

Figure 4-3. Block Diagram Atmel e5551



4.2.8 Power-on Reset (POR)

The power-on reset is a delay reset which is triggered when supply voltage is applied.

4.2.9 Mode Register

The mode register stores the mode data from EEPROM block 0. It is continually refreshed at the start of every block. This increases the reliability of the device (if the originally loaded mode information is false, it will be corrected by subsequent refresh cycles).

4.2.10 Modulator

The modulator consists of several data encoders in two stages, which may be freely combined to obtain the desired modulation. The basic types of modulation are:

- PSK: phase shift: 1) every change; 2) every '1'; 3) every rising edge (carrier: $f_c/2$, $f_c/4$ or $f_c/8$)
- FSK: 1) $f_1 = rf/8$, $f_2 = rf/5$; 2) $f_1 = rf/8$, $f_2 = rf/10$
- Manchester: rising edge = H; falling edge = L
- Biphase: every bit creates a change, a data 'H' creates an additional mid-bit change

Note: The following modulation type combinations will not work:

- Stage1 Manchester or biphase, stage2 PSK2, at any PSK carrier frequency (because the first stage output frequency is higher than the second stage strobe frequency)
- Stage1 Manchester or biphase and stage2 PSK with bitrate = $rf/8$ and PSK carrier frequency = $rf/8$ (for the same reason as above)
- Any stage1 option with any PSK for bitrates $rf/50$ or $rf/100$ if the PSK carrier frequency is not an integer multiple of the bitrate (e.g., $br = rf/50$, $PSKcf = rf/4$, because $50/4 = 12.5$). This is because the PSK carrier frequency must maintain constant phase with respect to the bit clock.

4.2.11 Memory

The memory of the Atmel® e5551 is a 264 bit EEPROM, which is arranged in 8 blocks of 33 bits each. All 33 bits of a block, including the lock bit, are programmed simultaneously. The programming voltage is generated on-chip.

Block 0 contains the mode data, which are not normally transmitted (see Figure 4-5).

Block 1 to 6 are freely programmable. Block 7 may be used as a password. If password protection is not required, it may be used for user data.

Bit 0 of every block is the lock bit for that block. Once locked, the block (including the lockbit itself) cannot be field-reprogrammed.

Data from the memory is transmitted serially, starting with block 1, bit 1, up to block 'MAXBLK', bit 32. 'MAXBLK' is a mode parameter set by the user to a value between 0 and 7 (if maxblk=0, only block 0 will be transmitted).

Figure 4-4. Memory Map

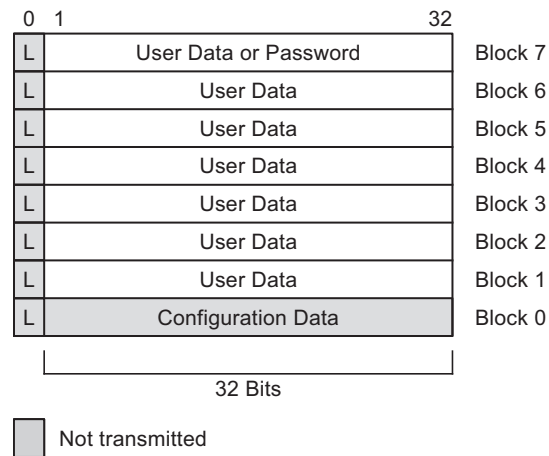

Figure 4-5. Modulator Block Diagram

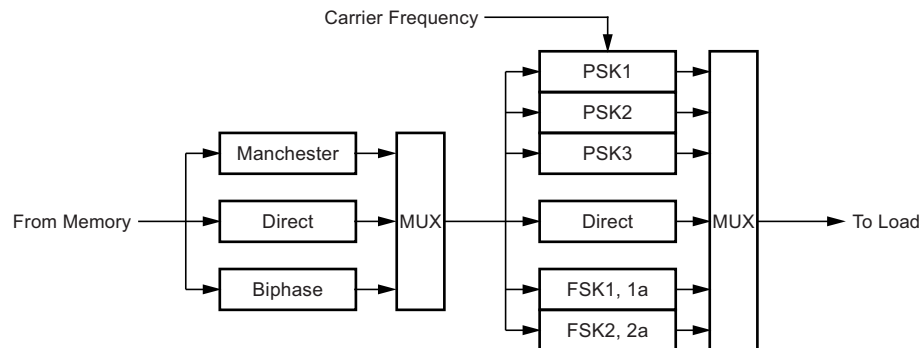
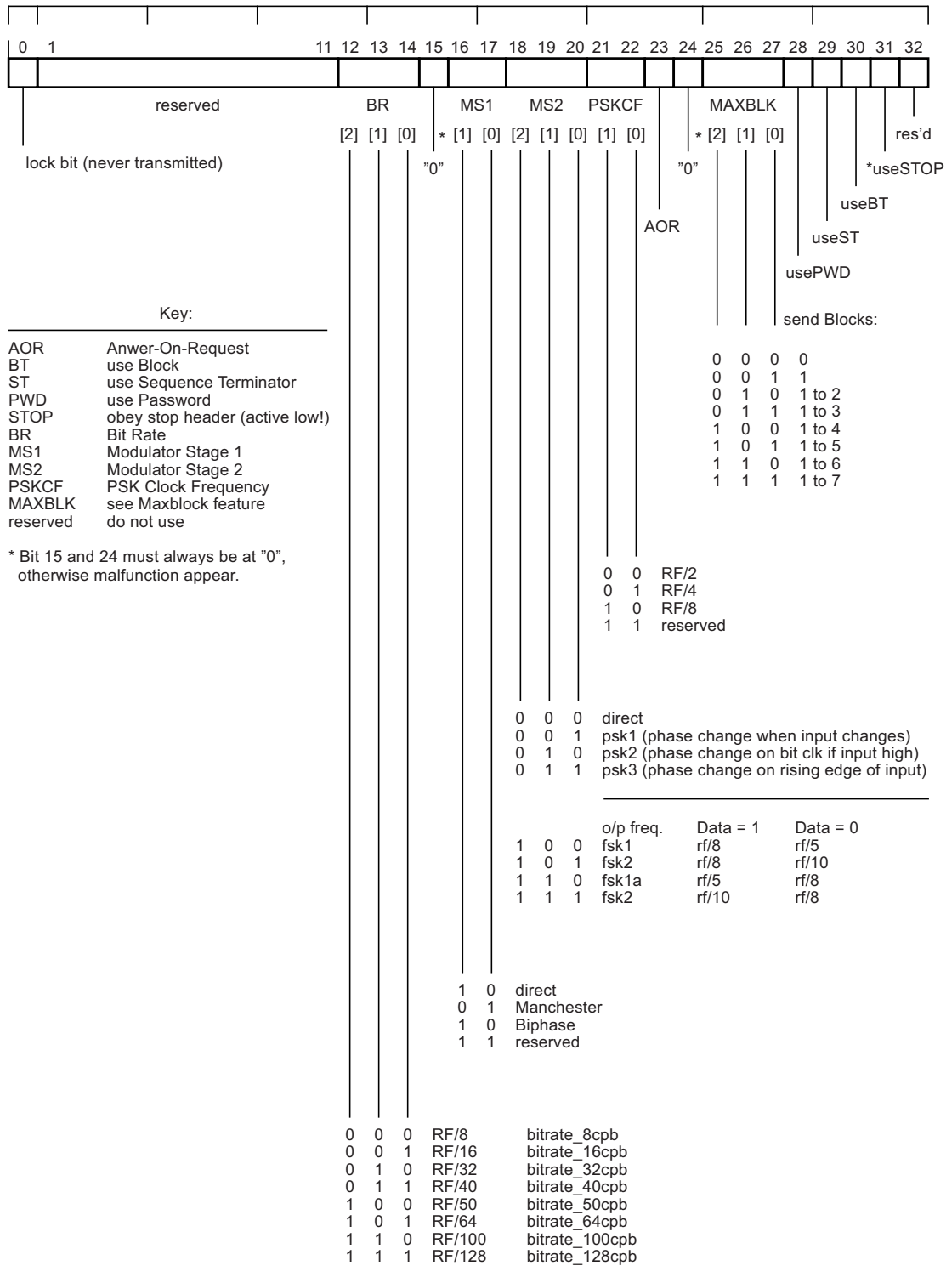

Figure 4-6. Memory Map of Block 0



4.3 Operating the Atmel e5551

4.3.1 General

The basic functions of the Atmel® e5551 are: supply IC from the coil, read data from the EEPROM to the reader, write data into the IC and program these data into the EEPROM. Several errors can be detected to protect the memory from being written with the wrong data (see [Figure 4-21 on page 15](#)).

4.3.2 Supply

The Atmel e5551 is supplied via a tuned LC circuit which is connected to the Coil 1 and Coil 2 pads. The incoming RF (actually a magnetic field) induces a current into the coil. The on-chip rectifier generates the dc supply voltage (VDD, VSS pads). Overvoltage protection prevents the IC from damage due to high-field strengths. Depending on the coil, the open-circuit voltage across the LC circuit can reach more than 100V. The first occurrence of RF triggers a power-on reset pulse, ensuring a defined start-up state.

4.3.3 Read

Reading is the default mode after power-on reset. It is done by switching a load between the coil pads on and off. This changes the current through the IC coil, which can be detected from the reader unit.

4.3.4 Start-up

The many different modes of the Atmel e5551 are activated after the first readout of block 0. The modulation is off while block 0 is read. After this set-up time of 256 field clock periods, modulation with the selected mode starts. Any field gap during this initialization will restart the complete sequence.

4.3.5 Read Datastream

The first block transmitted is block 1. When the last block is reached, reading restarts with block 1. Block 0, which contains mode data, is normally never transmitted. However, the mode register is continuously refreshed with the contents of EEPROM block 0.

Figure 4-7. Application Circuit

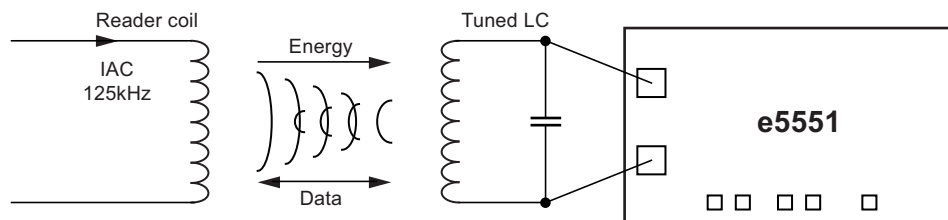

Figure 4-8. Voltage at Coil1/Coil2 after Power-on

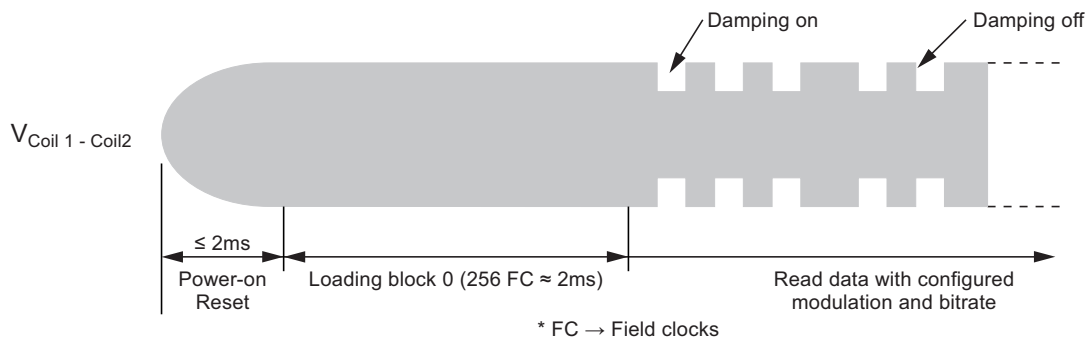

Figure 4-9. Terminators

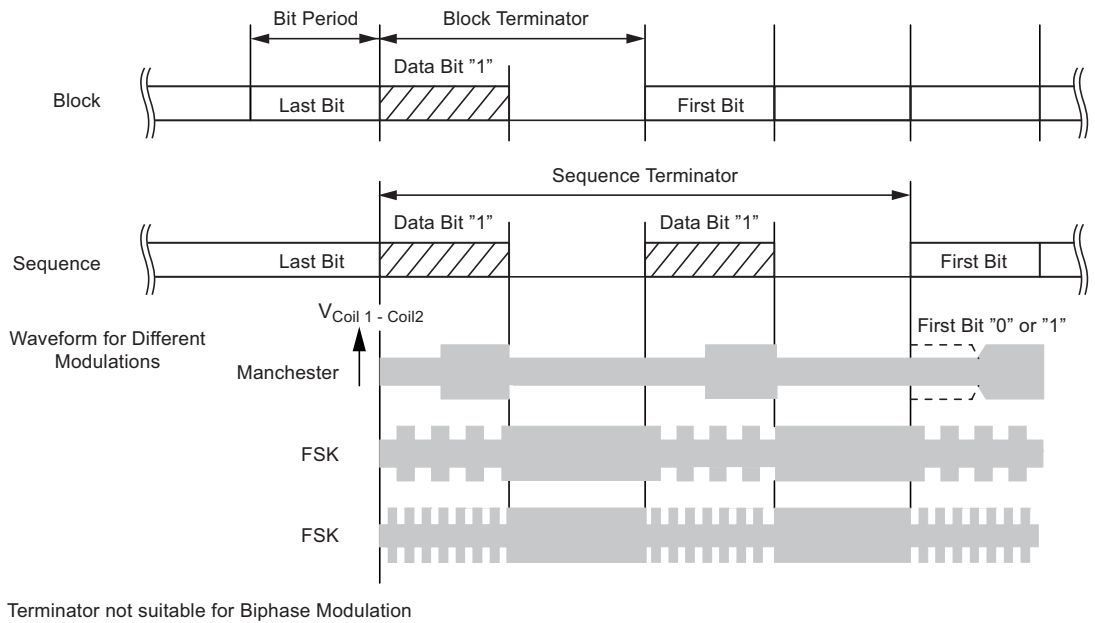

Figure 4-10. Read Data Streams and Terminators

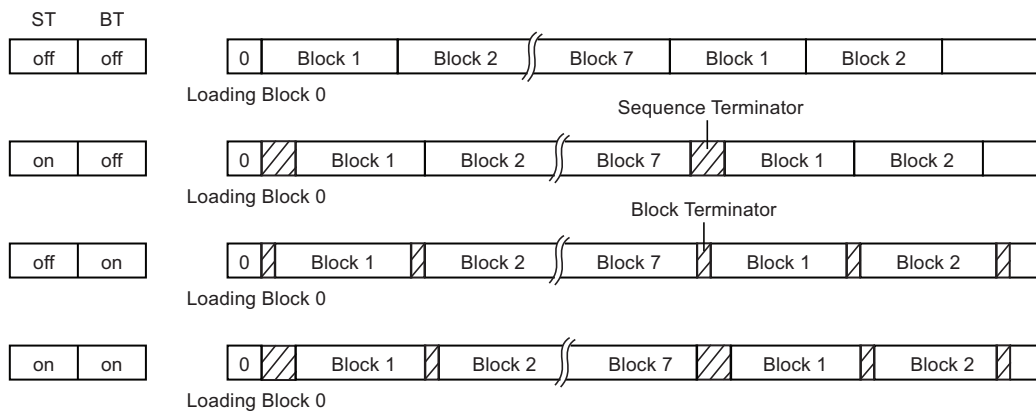
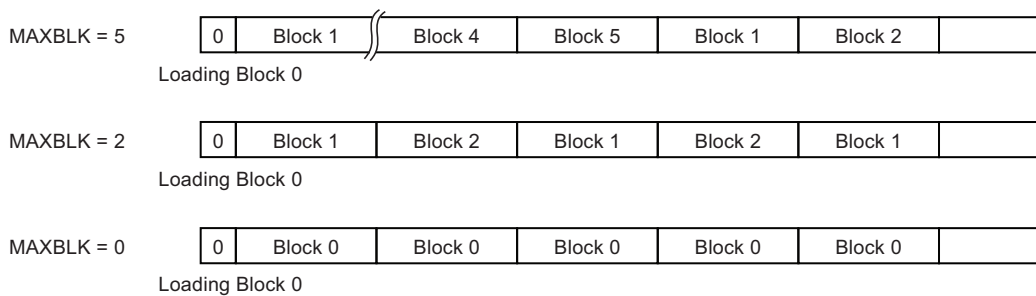

Figure 4-11. MAXBLK Examples



4.3.6 Maxblock Feature

If it is not necessary to read all user data blocks; the MAXBLK field in block 0 can be used to limit the number of blocks read. For example, if MAXBLK = 5, the Atmel® e5551 repeatedly reads and transmits only blocks 1 to 5 (see [Figure 4-10 on page 9](#)). If MAXBLK is set to '0', block 0 – which is normally not transmitted – can be read.

4.3.7 Terminators

The terminators are (optionally selectable) special damping patterns, which may be used to synchronize the reader. There are two types available; a block terminator which precedes every block, and a sequence terminator which always follows the last block.

The sequence terminator consists of two consecutive block terminators. The terminators may be individually enabled with the mode bits ST (sequence terminator enable) or BT (block terminator enable).

Note: It is not possible to include a sequence terminator in a transmission where MAXBLK = 0.

4.3.8 Direct Access

The direct access command allows the reading of an individual block by sending the OP-code ('10'), the lock-bit and the 3-bit address.

Note: PWD has to be 0.

4.3.9 Modulation and Bitrate

There are two modulator stages in the Atmel e5551 (see [Figure 4-3 on page 5](#)) whose mode can be selected using the appropriate bits in block 0 (MS1[1:0] and MS2[2:0]). Also the bitrate can be selected using BR[2:0] in block 0. These options are described in detail in [Figure 4-23 on page 17](#) through [Figure 4-26 on page 20](#).

4.3.10 Anticollision Mode

When the AOR bit is set, the IC does not start modulation after loading configuration block 0. It waits for a valid AOR data stream (wake-up command) from the reader before modulation is enabled.

The wake-up command consists of the OP-code ('10') following by a valid password. The IC will remain active until the RF field is turned off or a stop OP-code is received.

Table 4-1. Atmel e5551 - Modes of Operation

PWD	AOR	STOP	Behavior of Tag after Reset/POR	STOP Function
1	1	0	Anticollision mode: <ul style="list-style-type: none"> • Modulation starts after wake-up with a matching PWD • Programming needs valid PWD • AOR allows programming with read protection (no read after write) 	STOP OP-code ('11') defeats modulation until RF field is turned off
1	0	0	Password mode: <ul style="list-style-type: none"> • Modulation starts after reset • Programming needs valid PWD 	
0	1	0	<ul style="list-style-type: none"> • Modulation starts after wake-up command • Programming with modulation defeat without previous wake-up possible • AOR allows programming with read protection (no read after write) 	
0	0	0	<ul style="list-style-type: none"> • Modulation starts after reset • Direct access command • Programming without password 	
x	0	1	See corresponding modes above	
				STOP OP-code ignored, modulation continues until RF field is turned off

Figure 4-12. Answer-on-request (AOR) Mode

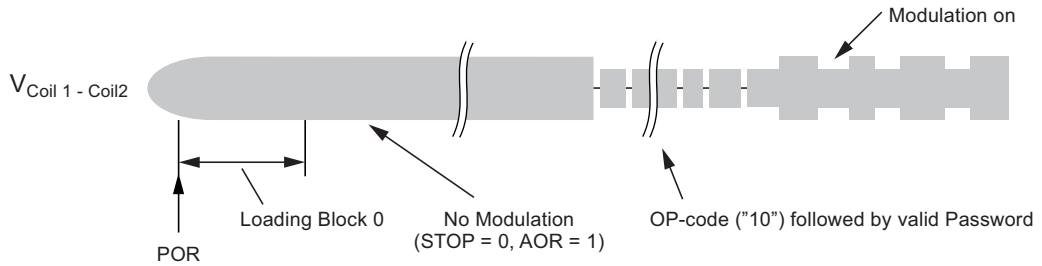
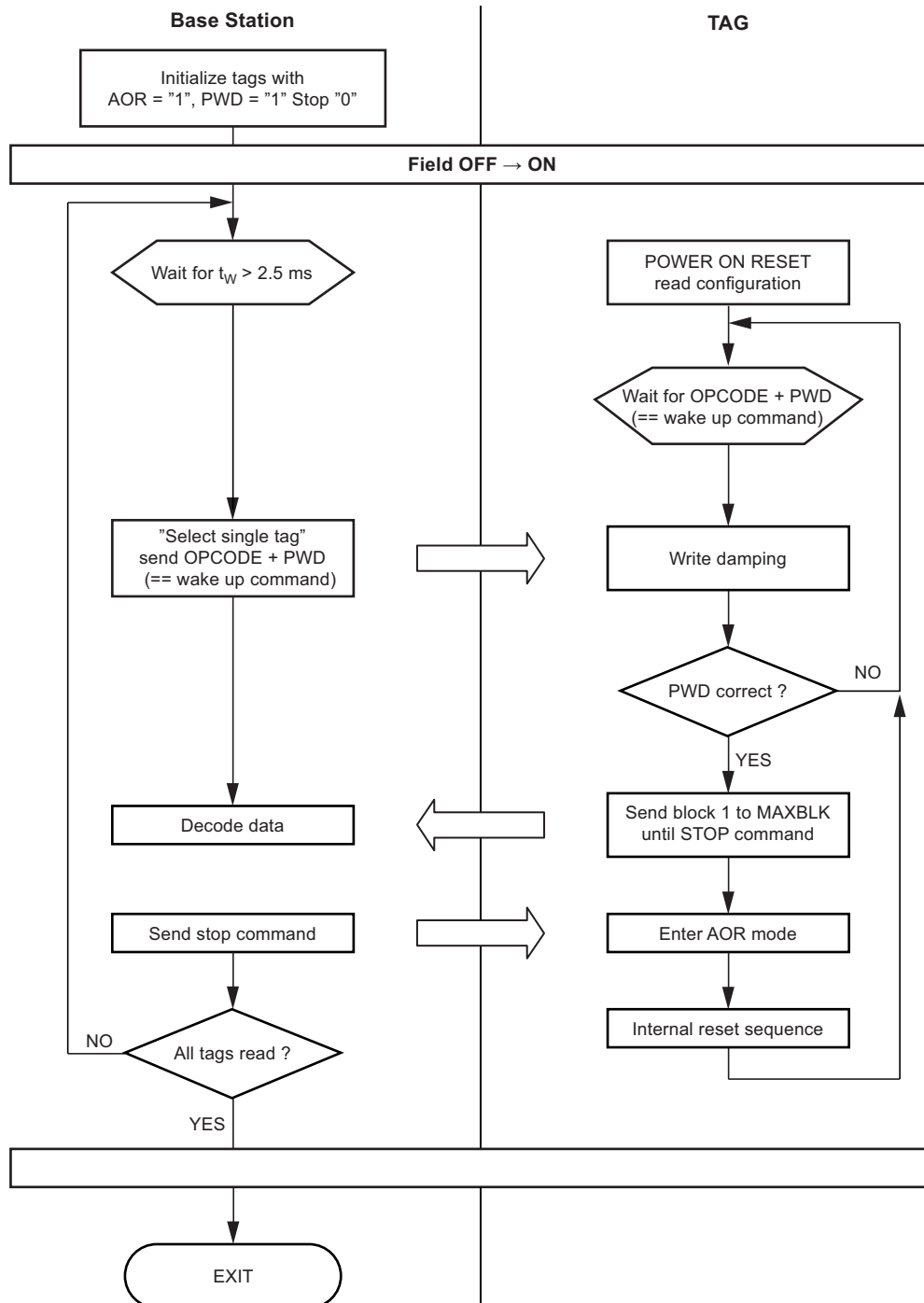

Figure 4-13. Anticollision Procedure



4.3.11 Writing Data into the Atmel ATA5551M-PPMY

Writing data into the IC occurs via the Atmel write method. It is based on interrupting the RF field with short gaps. The time between two gaps encodes the '0/1' information to be transmitted.

The write sequence of the Atmel® ATA5551M-PPMY is shown below. Writing data into the transponder occurs by interrupting the RF field with short gaps. After the start gap the standard write OP code (10) is followed by the lock bit. The next 32 bits contain the actual data. The last three bits denote the destination block address. If the correct number of bits have been received, the actual data is programmed into the specified memory block.

Figure 4-14. Write Protocol

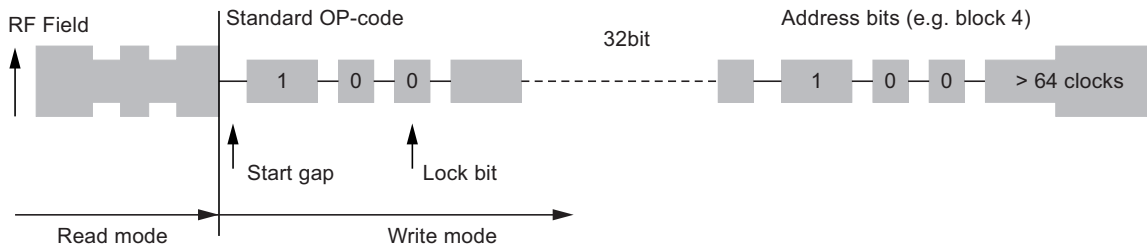
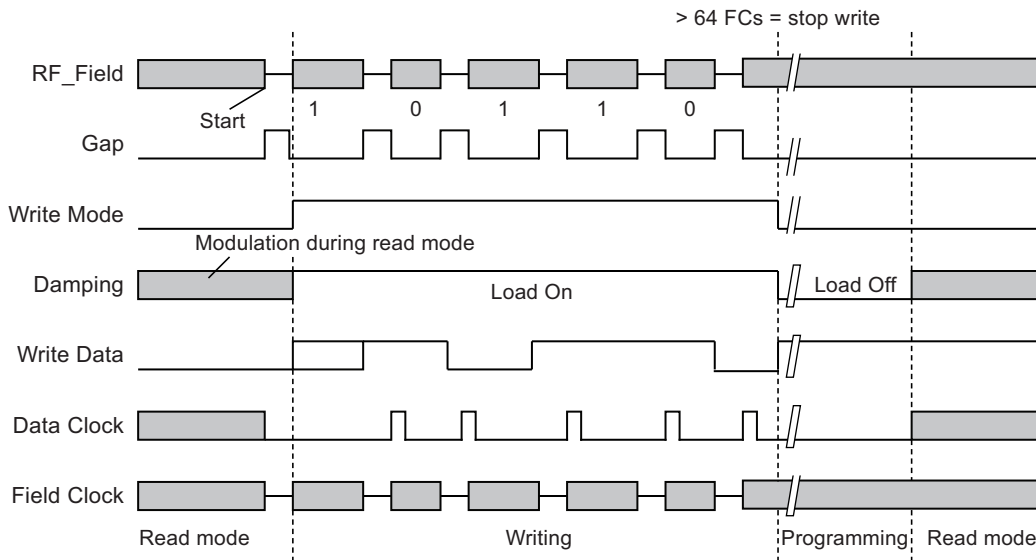

Figure 4-15. Signals during Writing



The time elapsing between two detected gaps is used to encode the information. As soon as a gap is detected, a counter starts counting the number of field clock cycles until the next gap is detected. Depending on how many field clocks elapse, the data is regarded as "0" or "1". The required number of field clocks is shown in Figure 4-16. A valid "0" is assumed if the number of counted clock periods is between 16 and 32, for a valid "1" it is 48 or 64 respectively. Any other value being detected results in an error, and the device exits write mode and returns to read mode.

Figure 4-16. Write Data Decoding Schemes

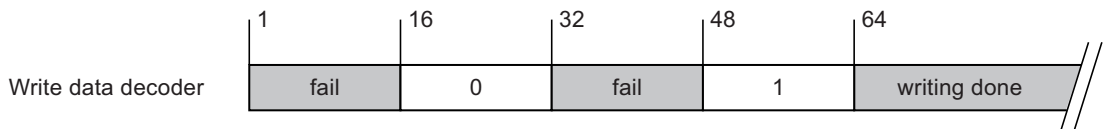
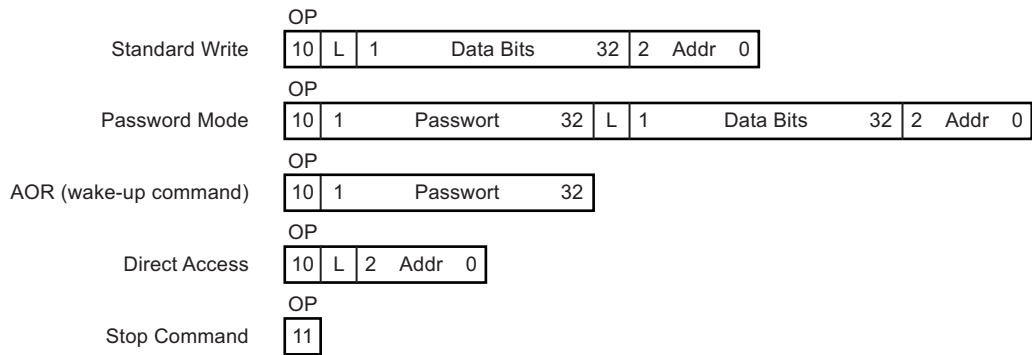

Figure 4-17. Atmel e5551 – OP-code Formats



4.3.12 Start Gap

The first gap is the start gap which triggers write mode. In write mode, the damping is permanently enabled which eases gap detection. The start gap may need to be longer than subsequent gaps in order to be detected reliably.

A start gap will be detected at any time after block 0 has been read (field-on plus approximately 2 ms).

Figure 4-18. Start of Writing

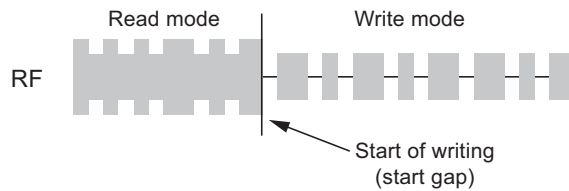

4.3.13 Decoder

The duration of the gaps is usually 50 to 150µs. The time between two gaps is nominally 24 field clocks for a '0' and 56 field clocks for a '1'. When there is no gap for more than 64 field clocks after previous gap, the IDIC exits write mode; it starts with programming if the correct number of valid bits were received.

If there is a gap fail - i.e., one or more of the intervals did represent not a valid '0' or '1' - the IC does not program, but enters read mode beginning with block 1, bit 1.

4.3.14 Writing Data into the Atmel e5551

The Atmel® e5551 expects a two bit OP-code first. There are two valid OP-codes ('10' and '11'). If the OP-code is invalid, the Atmel e5551 starts read mode beginning with block 1 after the last gap. The OP-code ('10') is followed by different information (see [Figure 4-16 on page 12](#)):

- Standard writing needs the OP-code, the lock bit, the 32 data bits and the 3-bit block address.
- Writing with usePWD set requires a valid password between OP-code and address/data bits.
- In AOR mode with usePWD, OP-code and a valid password are necessary to enable modulation.
- The STOP OP-code is used to silence the e5551 (disable damping until power is cycled).

Note: The data bits are read in the same order as written.

4.3.15 STOP OP-Code

The STOP OP-code ('11') is used to stop modulation until a power-on reset occurs. This feature can be used to have a steady RF field where single transponders are collected one by one. Each IC is read and then disabled, so that it does not interfere with the next IC.

Note: The STOP OP-code should contain only the two OP-code bits to disable the IC. Any additional data sent will not be ignored, and the IC will not stop modulation.

Figure 4-19. OP-code Transmission

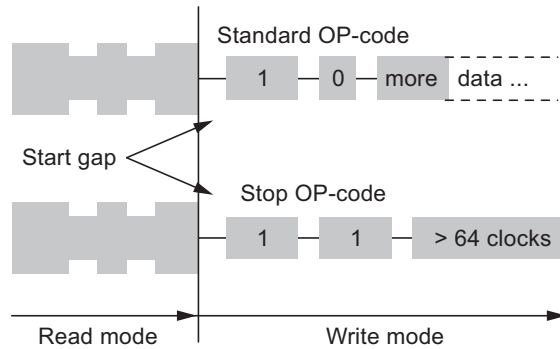

4.3.16 Password

When password mode is on (usePWD = 1), the first 32 bits after the OP-Code are regarded as the password. They are compared bit-by-bit with the contents of block 7, starting at bit 1. If the comparison fails, the IC will not program the memory, but restart in read mode at block 1 once writing has completed.

Notes:

- If PWD is not set, but the IC receives a write datastream containing any 32 bits in place of a password, the IC will enter programming mode.
- In password mode, MAXBLK should be set to a value below 7 to prevent the password from being transmitted by the Atmel® e5551.
- Every transmission of 2 OP-code bits, 32 password bits, one lock bit, 32 data bits and 3 address bits (= 70 bits) needs about 35 ms. Testing all 2^{32} possible combinations (about 4.3 billion) takes about 40,000 h, or over four years. This is a sufficient password protection for a general-purpose IDIC.

Figure 4-20. Programming

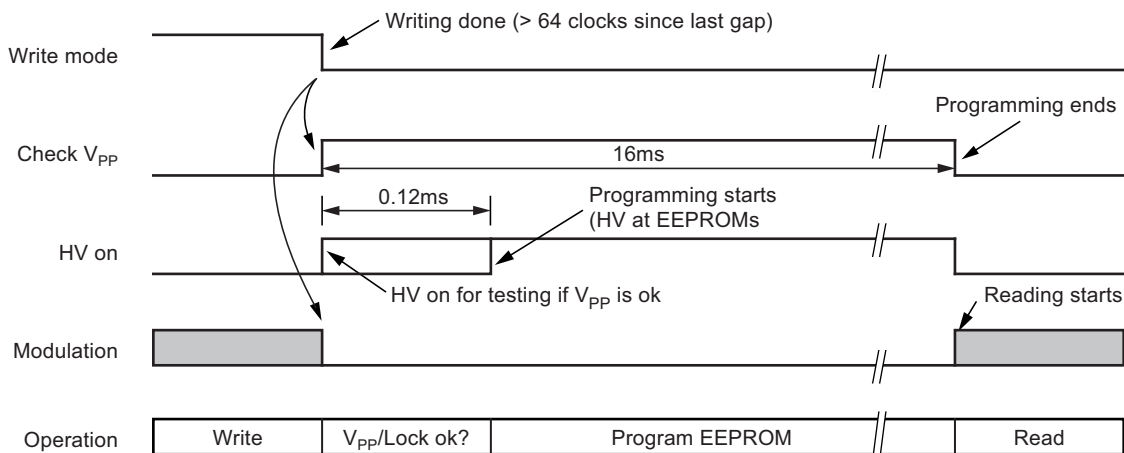
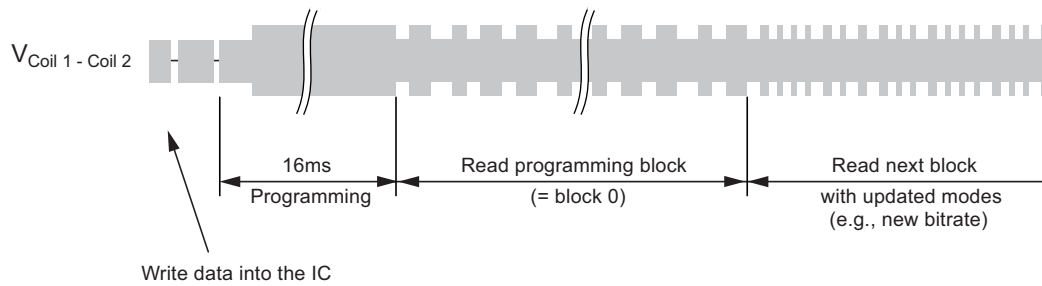

Figure 4-21. Coil Voltage after Programming of Block 0



4.3.17 Programming

When all necessary information has been written to the Atmel® e5551, programming may proceed. There is a 32-clock delay between the end of writing and the start of programming. During this time, V_{pp} - the EEPROM programming voltage - is measured and the lock bit for the block to be programmed is examined. Further, V_{pp} is continually monitored throughout the programming cycle. If at any time V_{pp} is too low, the chip enters read mode immediately.

The programming time is 16 ms.

After programming is done, the Atmel e5551 enters read mode, starting with the block just programmed. If either block or sequence terminators are enabled, the block is preceded by a block terminator. If the mode register (block 0) has been reprogrammed, the new mode will be activated after the just-programmed block has been transmitted using the previous mode.

4.3.18 Error Handling

Several error conditions can be detected to ensure that only valid bits are programmed into the EEPROM. There are two error types which lead to different actions.

4.3.19 Errors during Writing

There are four detectable errors which could occur during writing data into the Atmel e5551:

- Wrong number of field clocks between two gaps
- The OP-code is neither the standard OP-code ('10') nor the stop OP-code ('11')
- Password mode is active but the password does not match the contents of block 7
- The number of bits received is incorrect; valid bit counts are
 - Standard write 38 bits (PWD not set)
 - Password write 70 bits (PWD set)
 - AOR wake-up 34 bits
 - Stop command 2 bits

If any of these four conditions are detected, the IC starts read mode immediately after leaving write mode. Reading starts with block 1.

4.3.20 Errors During Programming

If writing was successful, the following errors could prevent programming:

- The lock bit of the addressed block is set
- VPP is too low

In these cases, programming stops immediately. The IC reverts to read mode, starting with the currently addressed block.

Figure 4-22. Functional Diagram of the Atmel e5551

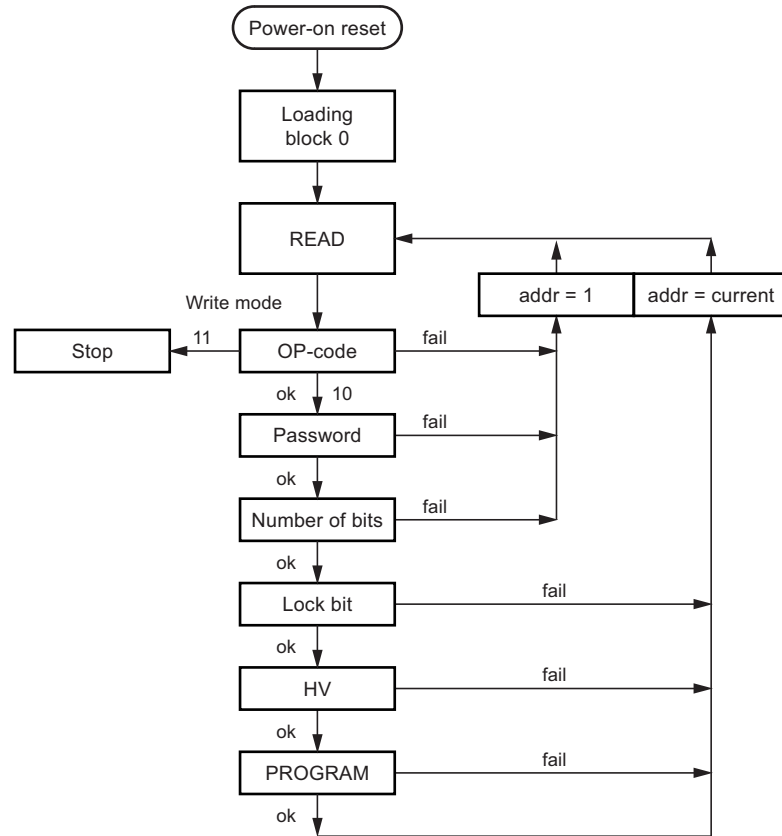

Figure 4-23. Example of Manchester Coding with Data Rate $R_F/16$

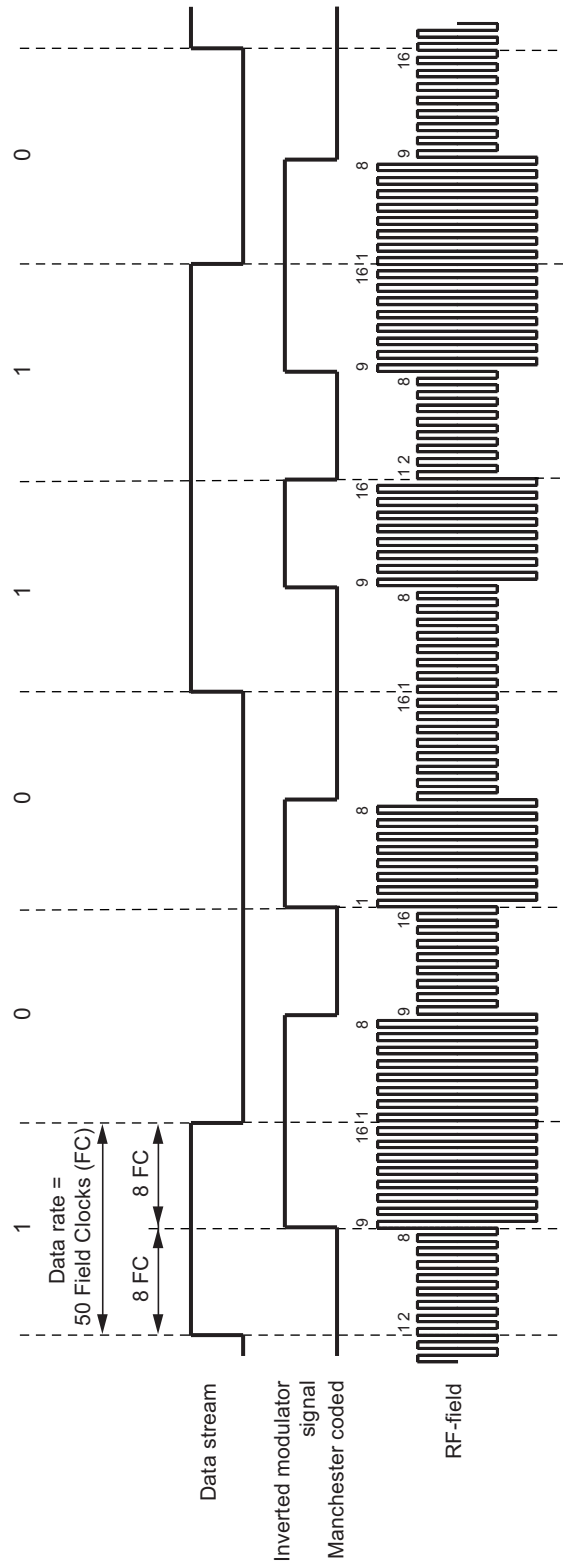

Figure 4-24. Example of Biphas Coding with Data Rate RF/16

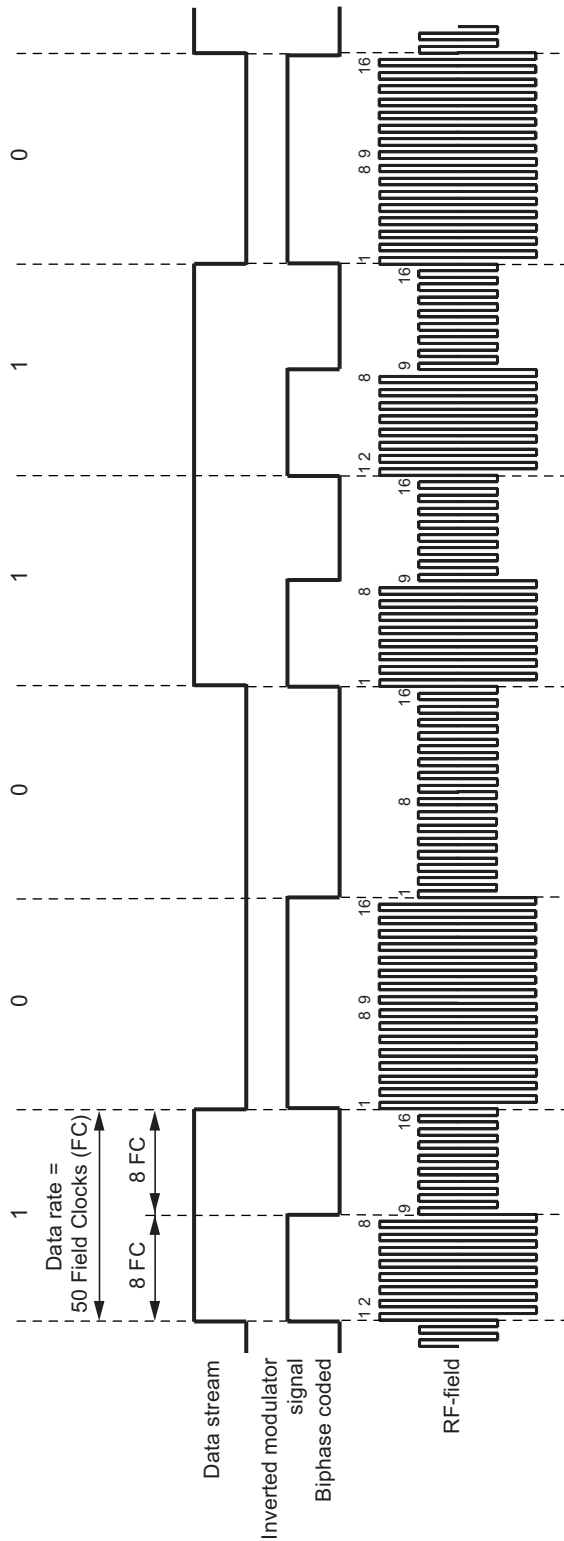

Figure 4-25. Example of FSK Coding with Data Rate $RF/40$, Subcarrier

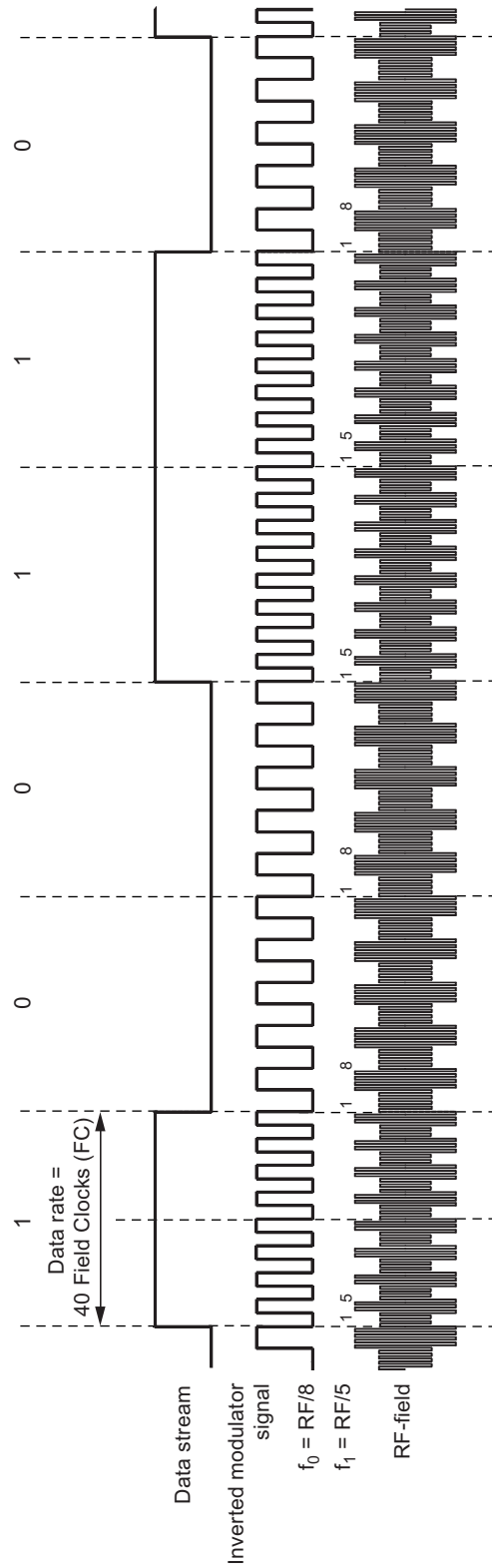

Figure 4-27. Example of PSK2 Coding with Data Rate RF/16

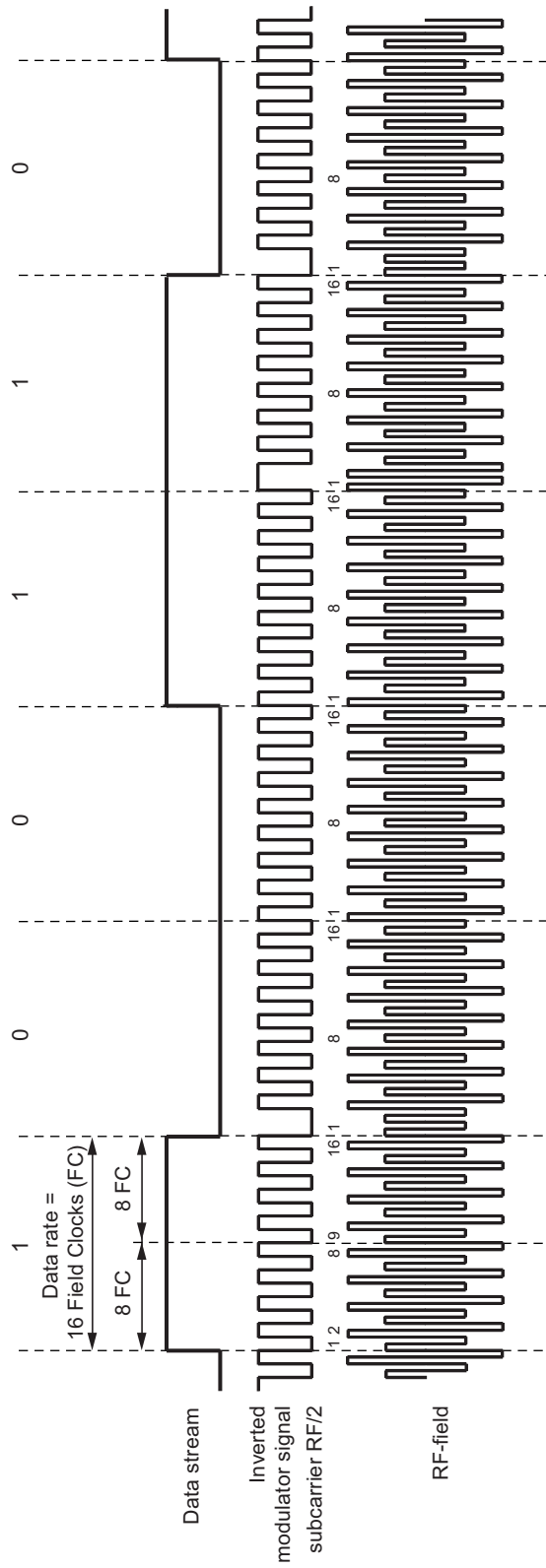
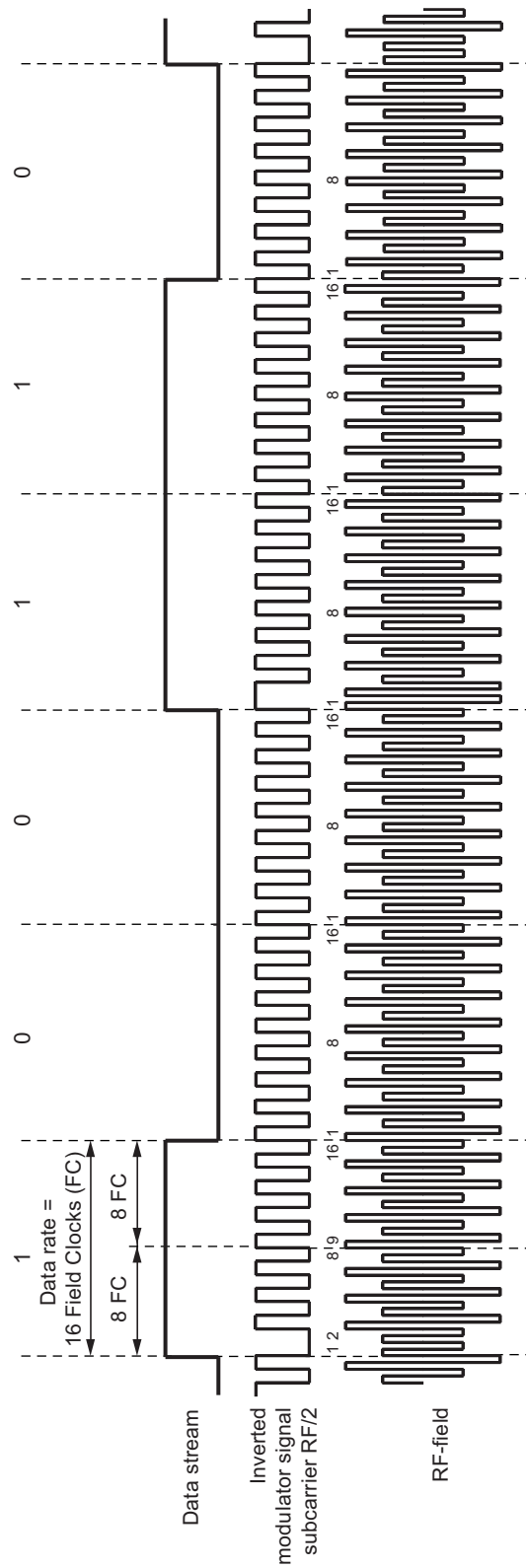

Figure 4-28. Example of PSK3 Coding with Data Rate RF/16



4.4 Operating Characteristics e5551

$T_{amb} = 25^{\circ}\text{C}$, $f_{RF} = 125\text{kHz}$

Parameters	Test Conditions	Symbol	Min.	Typ.	Max.	Unit
Programming time		t_p		18		ms
Startup time		$t_{startup}$			4	ms
Data retention	(1)	$t_{retention}$	10			Years
Programming cycles	(1)	n_{cycle}	100,000			

Note: 1. Since EEPROM performance may be influenced by assembly and packaging, we can confirm the parameters for dow (= die-on-wafer) and ICs assembled in standard package.

5. Absolute Maximum Ratings

Stresses beyond those listed under “Absolute Maximum Ratings” may cause permanent damage to the device. This is a stress rating only and functional operation of the device at these or any other conditions beyond those indicated in the operational sections of this specification is not implied. Exposure to absolute maximum rating conditions for extended periods may affect device reliability

Parameters	Symbol	Value	Unit
Operating temperature range	T_{amb}	-40 to +85	$^{\circ}\text{C}$
Storage temperature range	T_{stg}	-40 to +125	$^{\circ}\text{C}$
Assembly temperature $t < 5$ minutes	T_{ass}	170	$^{\circ}\text{C}$
Magnetic field strength at 125kHz	H_{pp}	1000	A/m

6. Operating Characteristics: Transponder

$T_{amb} = 25^{\circ}\text{C}$, $f = 125\text{kHz}$, unless otherwise specified

Parameters	Test Conditions	Symbol	Min.	Typ.	Max.	Unit	Type*
Inductance		L		4.0		mH	Q
LC Circuit							
Resonance frequency	Room temperature	f_r	120	125	130	kHz	T
Quality factor		Q_{LC}		31			Q
Magnetic Field Strength (H)							
Maximum field strength where tag does not modulate	No influence to other tags in the field	$H_{pp\ not}$		1.5		A/m	Q
Min. field strength for modulation		$H_{pp\ 25}$		18		A/m	Q
Min field strength for programming		H_{pp}		50		A/m	Q
Maximum field strength		$H_{pp\ max}$			600	A/m	Q

*) Type means: T: directly or indirectly tested during production; Q: based on initial product design

7. Measurement Assembly

All measurements are done with commercial RFID reader/writer supplied by “GIS”.

Figure 7-1. Testing Application

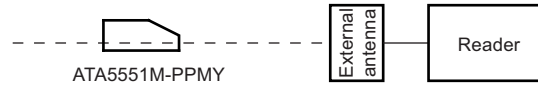

Reader type: TS-RW38 plus USB EA

Antenna type: TS-A50-K1000, circular antenna, inner diameter 51mm, L = 1.08mH

Supplier: GIS

8. Actual Behavior of the Device

The Atmel® ATA5551M-PPMY detects a gap if the voltage across the coils decreases below the threshold value of an internal MOS transistor. Until then, the clock pulses are counted. The number given for a valid “0” or “1” (see [Figure 4-16 on page 12](#)) refers to the actual clock pulses counted by the device. However, there are always more clock pulses being counted than were applied by the base station. The reason for this is the fact that an RF field cannot be switched off immediately. The coil voltage decreases exponentially. So although the RF field coming from the base station is switched off, it takes some time until the voltage across the coils reaches the threshold value of an internal MOS transistor and the device detects the gap.

Referring to the following diagram (see [Figure 8-1](#)), this means that the device uses the times $t_{0\text{ internal}}$ and $t_{1\text{ internal}}$. The exact times for t_0 and t_1 are dependent on the application (e.g., field strength, etc.).

Measured write-time frames of the IDIC demo kit software are:

$$t_0 = 50\mu\text{s to } 130\mu\text{s}$$

$$t_1 = 270\mu\text{s to } 390\mu\text{s}$$

$$t_{\text{gap}} = 180\mu\text{s to } 400\mu\text{s}$$

Antennas with a high Q-factor require longer times for t_{gap} and shorter time values for t_0 and t_1 .

Figure 8-1. Ideal and Real Behavior Signals

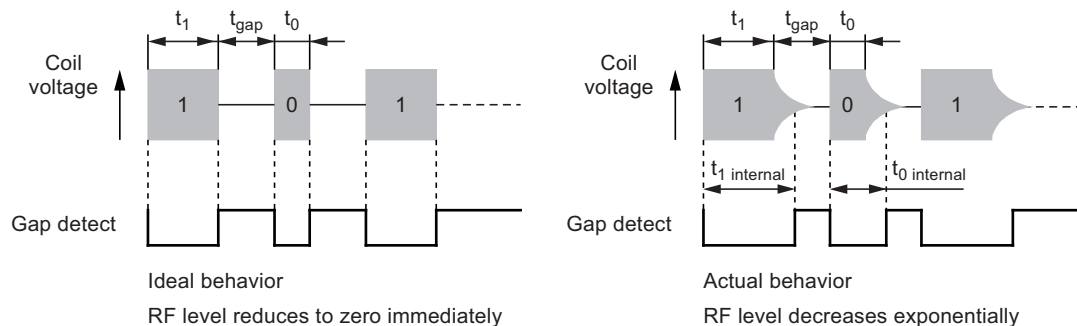

9. Operating Distance

The maximum distance between the base station and the Atmel ATA5551M-PPMY depends mainly on the reader station, the coil geometries and the modulation options chosen. Under laboratory conditions, a distance of up to 9cm can be reached. When using the Atmel RFID demo kit ATA2270-EK2, the typical distances in the range of 0cm to 5cm can be achieved.

10. Ordering Information

10.1 Available Ordering Codes

ATA5551M-PPMY

10.2 Configuration on Delivery

In production the transponder is configured as shown in [Table 10-1](#). All blocks are unlocked. Block 0 is the configuration register and is pre-programmed to the Atmel default operating mode. Manchester modulation with a data rate of RF/32. 2 data blocks (block 1 and block 2) are transmitted. The data setting in all blocks are listed in [Table 10-1](#).

Table 10-1. Configuration on Delivery

Block	Address	Value	Comment
Configuration	block 0	0x E608 8042	Manchester RF/32, Maxblock 2, disabled stop mode
Use data block 1	block 1	0x 7EFF FFFF	
Use data block 2	block 2	0x 7DFF FFFF	
Use data block 3	block 3	0x 7BFF FFFF	
Use data block 4	block 4	0x 77FF FFFF	
Use data block 5	block 5	0x 6FFF FFFF	
Use data block 6	block 6	0x 5FFF FFFF	
Use data block 7	block 7	0x 3FFF FFFF	

11. Package Information

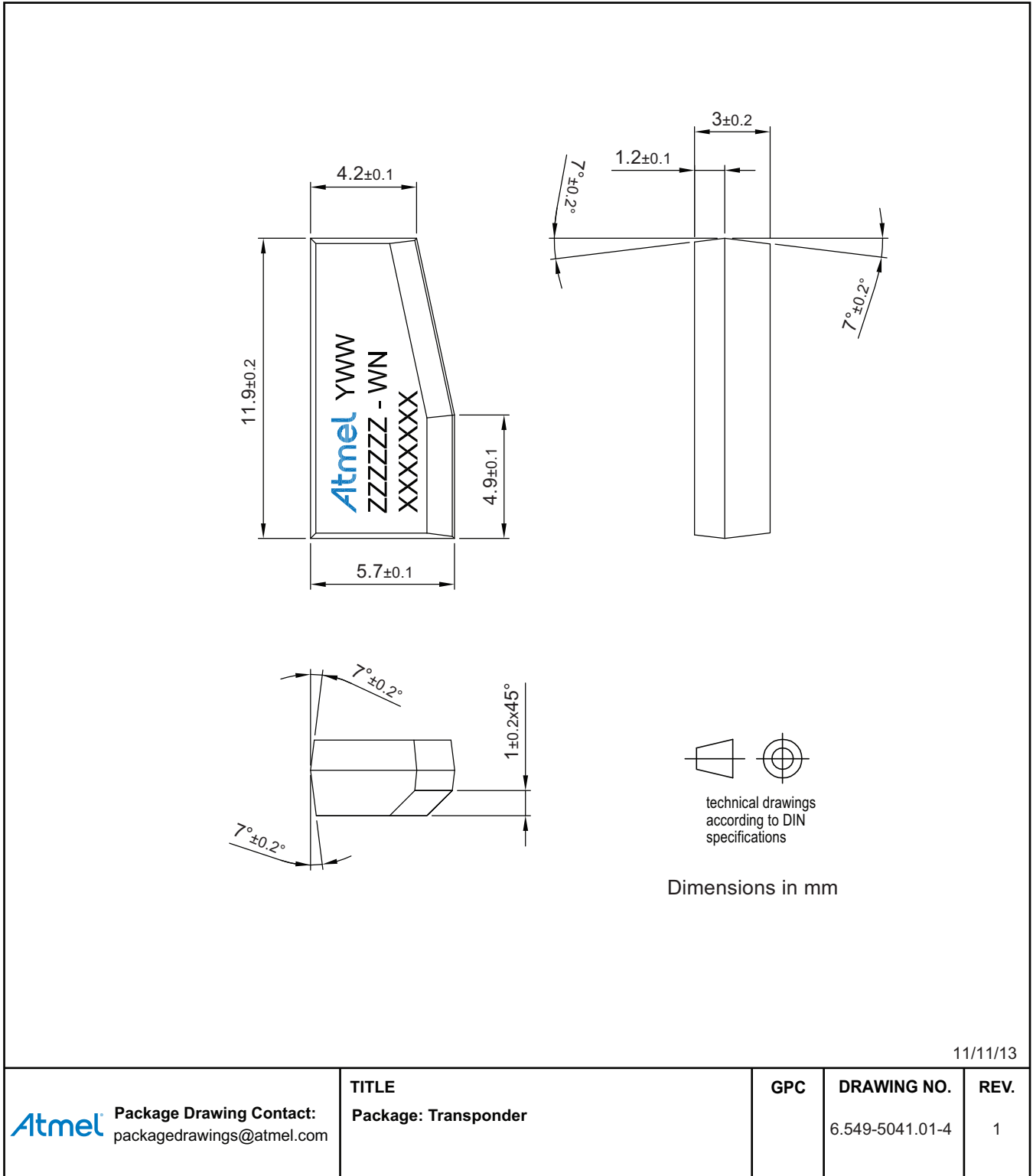

12. Revision History

Please note that the following page numbers referred to in this section refer to the specific revision mentioned, not to this document.

Revision No.	History
9334B-RFID-05/14	<ul style="list-style-type: none">• Section 6 “Operating Characteristics: Transponder” on page 23 updated• Section 7 “Measurement Assembly” on page 24 updated



Atmel Corporation 1600 Technology Drive, San Jose, CA 95110 USA T: (+1)(408) 441.0311 F: (+1)(408) 436.4200 | www.atmel.com

© 2014 Atmel Corporation. / Rev.: Rev.: 9334B–RFID–05/14

Atmel®, Atmel logo and combinations thereof, Enabling Unlimited Possibilities®, and others are registered trademarks or trademarks of Atmel Corporation in U.S. and other countries. Other terms and product names may be trademarks of others.

DISCLAIMER: The information in this document is provided in connection with Atmel products. No license, express or implied, by estoppel or otherwise, to any intellectual property right is granted by this document or in connection with the sale of Atmel products. EXCEPT AS SET FORTH IN THE ATMEL TERMS AND CONDITIONS OF SALES LOCATED ON THE ATMEL WEBSITE, ATMEL ASSUMES NO LIABILITY WHATSOEVER AND DISCLAIMS ANY EXPRESS, IMPLIED OR STATUTORY WARRANTY RELATING TO ITS PRODUCTS INCLUDING, BUT NOT LIMITED TO, THE IMPLIED WARRANTY OF MERCHANTABILITY, FITNESS FOR A PARTICULAR PURPOSE, OR NON-INFRINGEMENT. IN NO EVENT SHALL ATMEL BE LIABLE FOR ANY DIRECT, INDIRECT, CONSEQUENTIAL, PUNITIVE, SPECIAL OR INCIDENTAL DAMAGES (INCLUDING, WITHOUT LIMITATION, DAMAGES FOR LOSS AND PROFITS, BUSINESS INTERRUPTION, OR LOSS OF INFORMATION) ARISING OUT OF THE USE OR INABILITY TO USE THIS DOCUMENT, EVEN IF ATMEL HAS BEEN ADVISED OF THE POSSIBILITY OF SUCH DAMAGES. Atmel makes no representations or warranties with respect to the accuracy or completeness of the contents of this document and reserves the right to make changes to specifications and products descriptions at any time without notice. Atmel does not make any commitment to update the information contained herein. Unless specifically provided otherwise, Atmel products are not suitable for, and shall not be used in, automotive applications. Atmel products are not intended, authorized, or warranted for use as components in applications intended to support or sustain life.

SAFETY-CRITICAL, MILITARY, AND AUTOMOTIVE APPLICATIONS DISCLAIMER: Atmel products are not designed for and will not be used in connection with any applications where the failure of such products would reasonably be expected to result in significant personal injury or death ("Safety-Critical Applications") without an Atmel officer's specific written consent. Safety-Critical Applications include, without limitation, life support devices and systems, equipment or systems for the operation of nuclear facilities and weapons systems. Atmel products are not designed nor intended for use in military or aerospace applications or environments unless specifically designated by Atmel as military-grade. Atmel products are not designed nor intended for use in automotive applications unless specifically designated by Atmel as automotive-grade.