

IS-CHPMP User Manual

Revision B

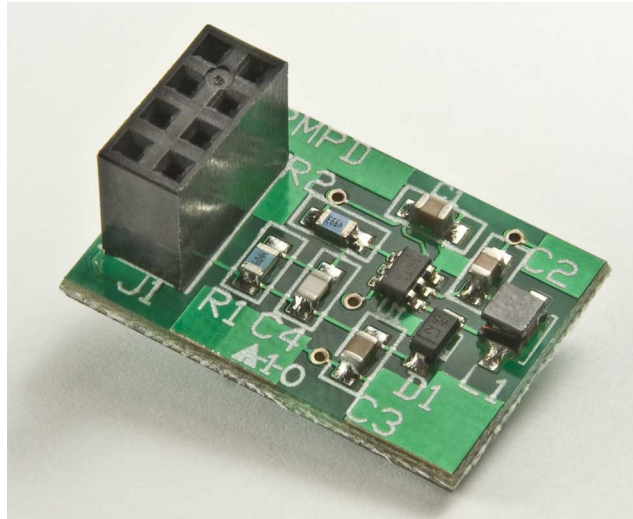

NKK SWITCHES

7850 E. Gelding Drive
Scottsdale, AZ 85260

Toll Free 1-877-2BUYNKK (877-228-9655)

Phone 480-991-0942

Fax 480-998-1435

e-mail <engineering@nkkswitches.com>

All Rights Reserved Worldwide

NKK Switches makes no warranty for the use of these products and assumes no responsibility for any errors, which may appear in this document, nor does it make a commitment to update the information contained herein. Smart Switch is trademark of NKK Switches.

TABLE OF CONTENTS

Table of Contents2

1. General Description.....3

2. Electrical Characteristics4

3. Pin Configurations.....4

4. Typical Operating Characteristics5

5. Schematic.....5

5. Build of Material6

5. Board Layout6

1. General Description.

The IS-CHPMP is a DC/DC voltage step-up converter with an input of 2.7-5.5V and an output of 16V for use in driving OLED displays. The IS-CHPMP utilizes Maxim's MAX8574 step-up converter to take advantage of its floating output during shutdown mode. A 2x4 .100" header is required to interface with charge pump.

IS-CHPMP is RoHS compliant.

Photo 1, Primary side

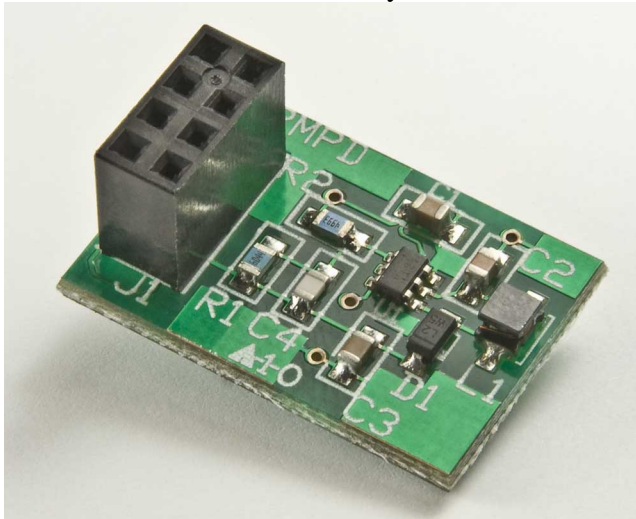
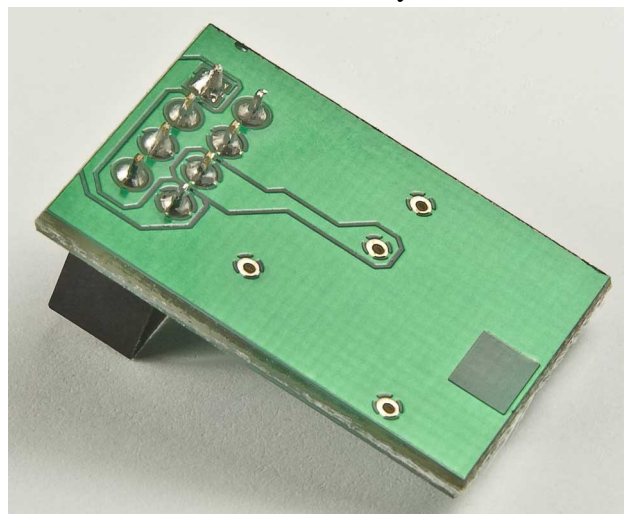

Photo 2, Secondary side



2. Electrical Characteristics

- 2.7-5.5V Input Voltage.
- 16V Output Voltage.
- Floating output when in shutdown mode.
- Current .05uA typical, 1uA maximum in shutdown mode.

3. Pin Configurations

Pin	Name	Function
1	V3.3	Input voltage supply between 2.7-5V.
2	V16	Output voltage preset to 16V.
3	SHTDN	Shutdown input. A logic high puts the MAX8574 into normal operation. A logic low at SHTDN places the MAX8574 into low-power shutdown mode.
4	GND	Ground
5	GND	Ground
6	SHTDN	Shutdown input. A logic high puts the MAX8574 into normal operation. A logic low at SHTDN places the MAX8574 into low-power shutdown mode.
7	V16	Output voltage preset to 16V.
8	V3.3	Input voltage supply between 2.7-5V.

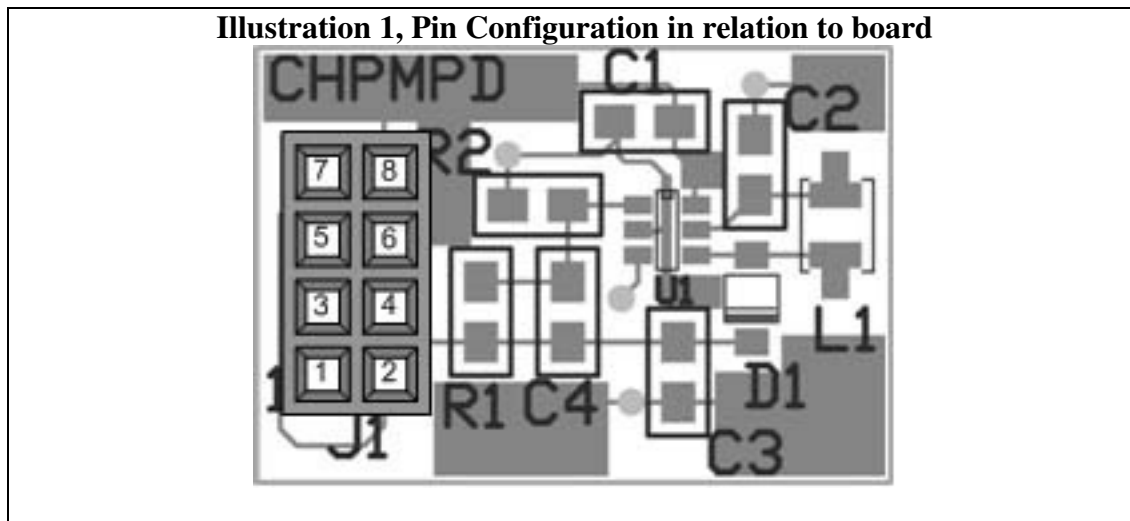

Note: Incorrect installation of the connector could damage the charge pump and/or the motherboard.

4. Typical Operating Characteristics

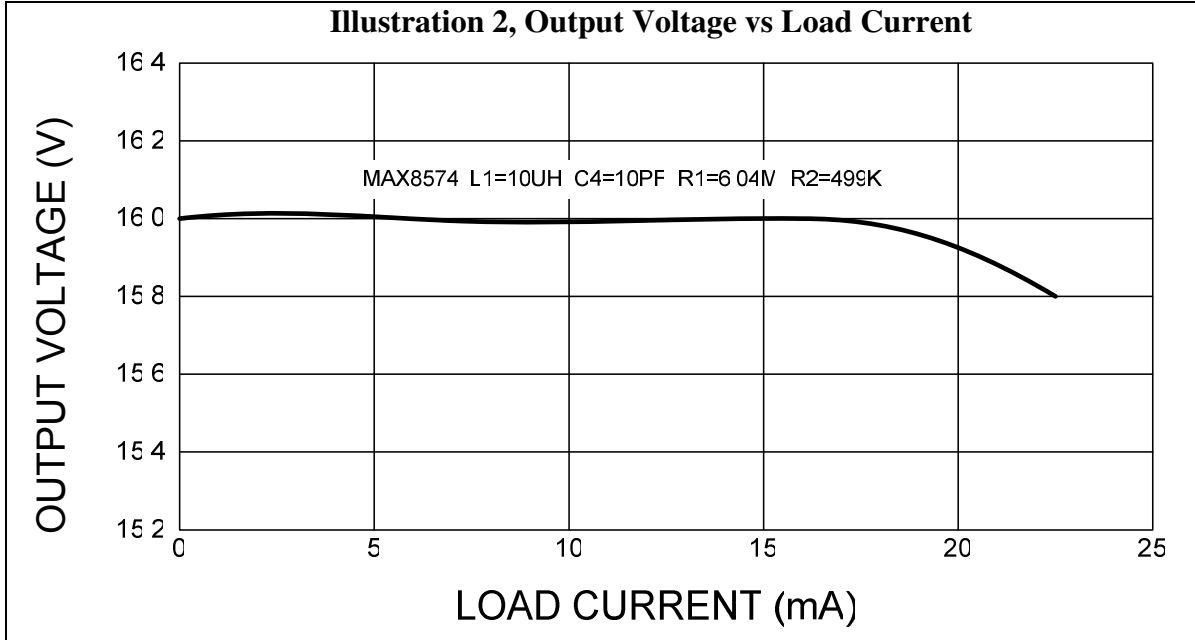

- 4.1. Testing was done using 3.3V input with constant load. Load was set for 16V output operation then increased until output voltage dropped 200mV.
- 4.2. Testing was done on eleven assemblies with a variation of 1% of graph.

5. Schematic

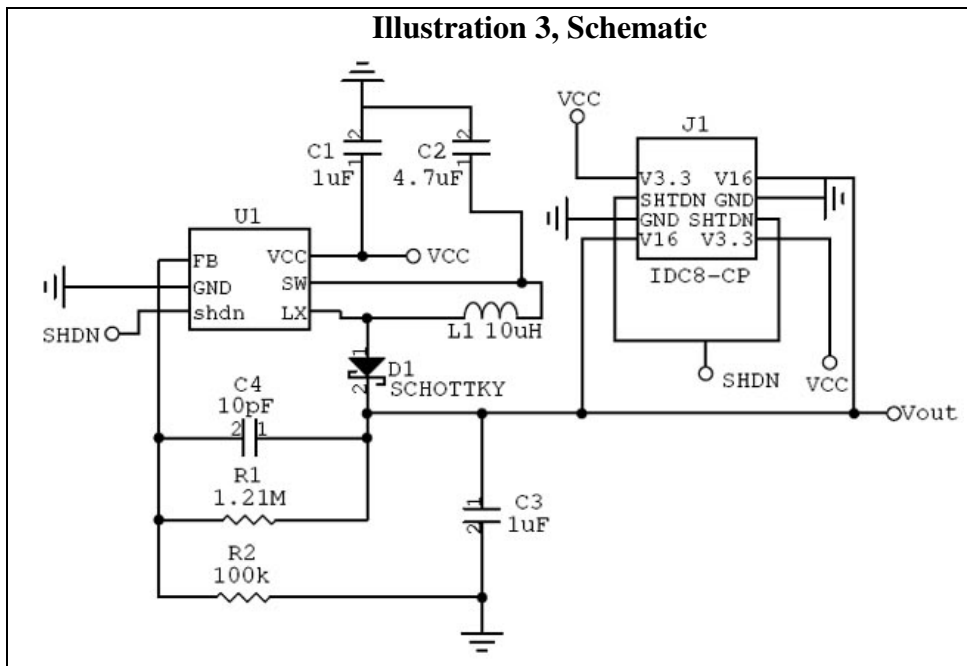

6. Build of Material

Item	Count	Designation	Part Number	Description	Value	Package
1	1	-	P-CHPMPD	PCB/OLED CHARGE PUMP/REV D	-	-
2	1	C1	MA0805XR105K160R	CAPACITOR/1UF/16V/SM0805 X7R	1UF	SM0805
3	1	C2	C2012X5R0J475K	CAPACITOR/4.7UF/6.3V/SM0805 X5R	4.7UF	SM0805
4	1	C3	GRM219R71E105KA88D	CAPACITOR/1UF/25V/SM0805 X7R	1UF	SM0805
5	1	C4	GRM2165C1H4R7CD01D	CAPACITOR/4.7PF/50V/SM0805/C0G	10PF	SM0805
6	1	D1	BAT42W-V-GS08	DIODE/SCHOTTKY/30V/0.200A/SOD-123		SOD-123
7	1	J1	PPPC042LFBN-RC	HEADER/2X4/GOLD/RECEPTACLE/FEMALE/2.54MM		THR HOLE
8	1	L1	LQH32CN100K33L	INDUCTOR/10UH/450MA/.300OHM/SMD	10UH	SMD
9	1	R1	RK73H2ATTD6044F	RESISTOR/6.04M/1/8W/1%/SM0805	6.04M	SM0805
10	1	R2	RK73H2ATTD4993F	RESISTOR/499K/1/8W/1%/SM0805	499K	SM0805
11	1	U1	MAX8574EUT+T	IC/SM SOT-23-6/LCD STEP-UP DC-DC CONVERTER		SOT-23-6

7. Board Layout

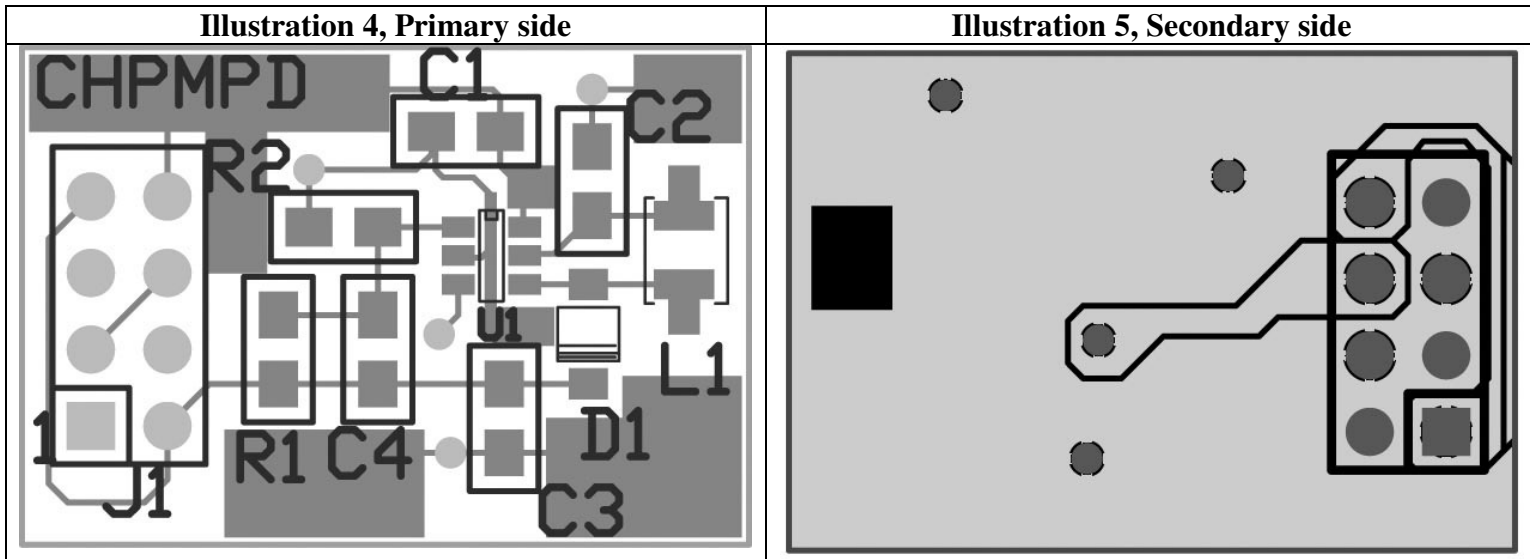

Note: No traces or ground plane shall be present under the inductor.