

2-PHASE DC MOTOR DRIVE IC

GENERAL DESCRIPTION

The FS210, a 1-chip composed of hall sensor and output coil drivers, applied to a 2-phase DC motor. The high sensitivity of Hall effect sensor is suitable for motors from mini-type CPU coolers to blowers and DC fans. Typical operation current up to 0.45A and operating voltage range is from 2.8V ~ 20V.

Using few external components, FS210, a high performance integrated IC, is designed for a single-phase DC motor circuit. The circuit diagram of the typical application example is as below.

FEATURES

- 1 chip hall sensor/drivers
- Wide operating voltage range: 2.8V~20V
- Output sink current up to 0.45A
- Very low switching noise.
- Package : TO-92SP-4

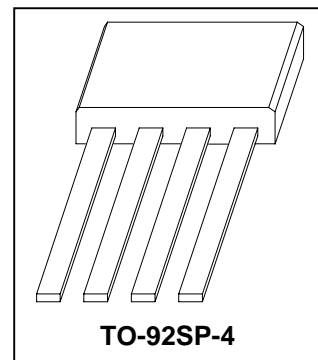

TYPICAL APPLICATION CIRCUIT

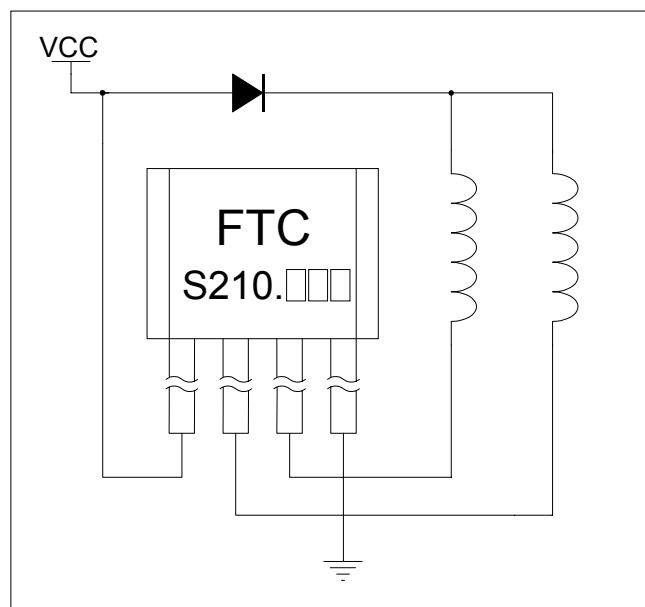

FUNCTIONAL BLOCK DIAGRAM

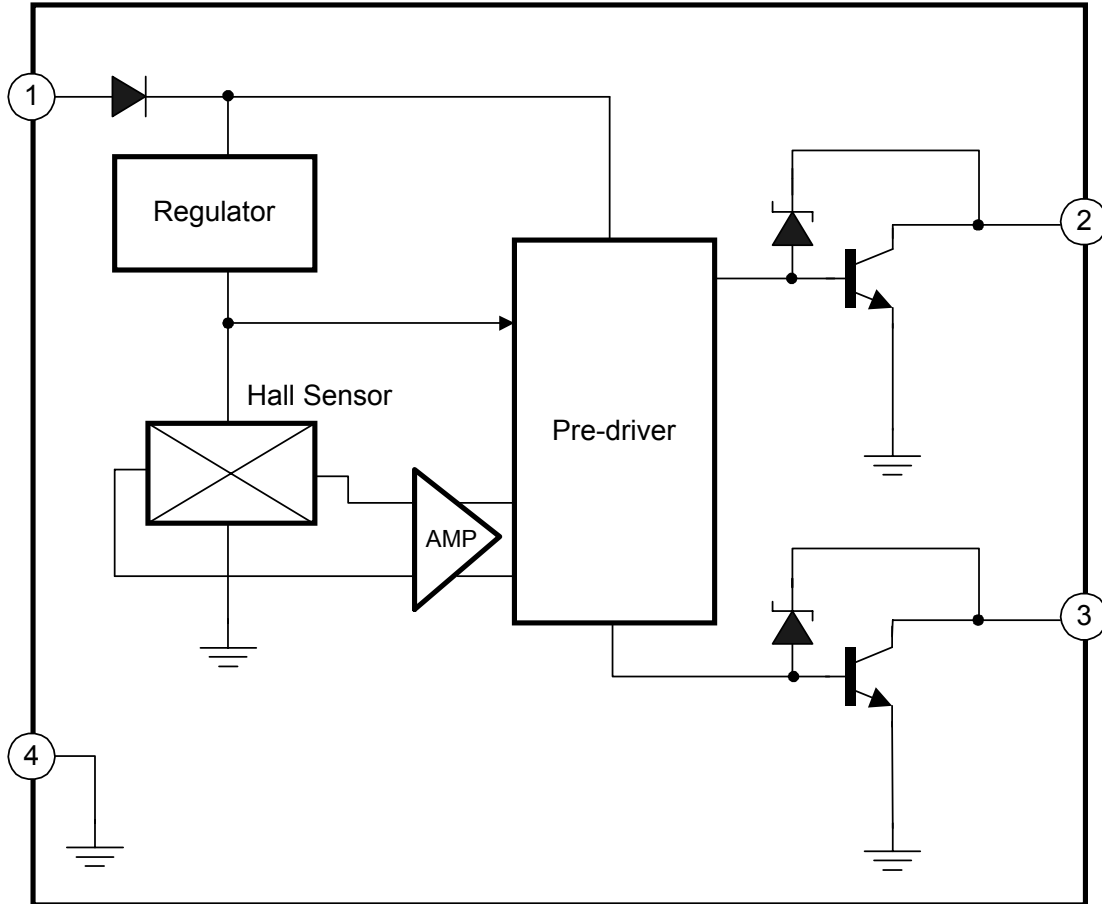

MARK VIEW

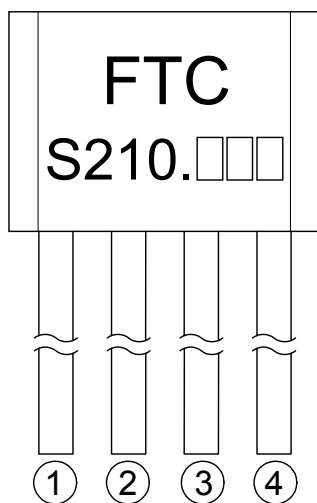

PIN DESCRIPTION

NAME	NO.	STATUS	DESCRIPTION
VCC	1	P	IC Power Supply
NO	2	O	Coil driver output It is low state during the N magnetic field.
SO	3	O	Coil driver output It is low state during the S magnetic field.
GND	4	P	IC Ground

ABSOLUTE MAXIMUM RATINGS

Zener Breakdown Voltage (Vz) -----	35V
NO/SO Pin Voltage -----	30V
VCC Pin Voltage -----	20V
Peak Sink Current (Io)	
Peak Current-----	1A/ 100us
Hold Current-----	700mA
Continuous Current -----	450mA
Power Dissipation	
Ta=25°C -----	850mW
Ta=85°C -----	450mW
Thermal Resistance	
Θ_{ja} = -----	0.15°C /mW
Operating Temperature Range -----	-20 °C 100 °C
Storage Temperature Range -----	-65 °C 150 °C
Junction Temperature -----	+150 °C
Lead Temperature (Soldering, 10 sec) -----	+230 °C

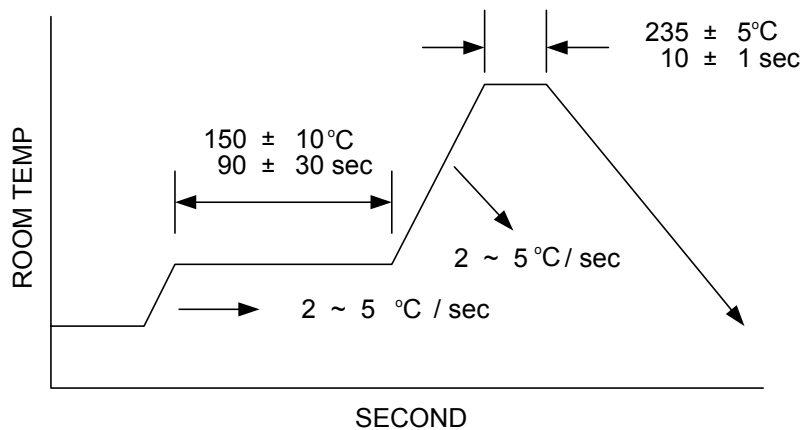

Soldering Condition

DC ELECTRICAL CHARACTERISTICS

PARAMETER	SYMBOL	TEST CONDITIONS	MIN	TYP	MAX	UNIT
Minimum Operating Voltage	V_{CC}	No use pin is open (Fig1)		2.8		V
Maximum Operating Voltage	V_{CC}	$I_{CC} < 20\text{mA}$ No use pin is open (Fig1)		20.0		V
Quiescent Supply current	I_{CC}	No use pin is open $V_{CC} : 3.0\text{V} \sim 20\text{V}$ (Fig1)		18	20	mA
NO/SO Saturation Voltage	V_{SAT}	$I_o = 450\text{mA}$ (Fig1)			1.0	V

Note: Fig1 The IC output state is under N magnetic field.

NO/SO Saturation Voltage Vs. Output Current(I_o) $V_{CC}=12\text{V}$, Temp.=25°C

Output Current (I_o), unit:mA	Saturation Voltage Unit:V	Note
200	0.30	
300	0.47	
400	0.66	
500	0.88	
600	1.09	
700	1.31	

NO/SO Saturation Voltage Vs. Operating Temperature

$V_{CC}=12\text{V}$, $I_o(\text{output current})=450\text{mA}$

Operating Temperature unit: °C	Saturation Voltage Unit:V	Note
-20	0.76	
0	0.77	
20	0.78	
40	0.79	
60	0.82	
80	0.85	
100	0.87	

NO/SO Maximum Output Current Vs. Operating Temperature

V_{cc}=12V

Operating Temperature unit: °C	Absolute Maximum Output Current Unit: mA	Note
20	700	
40	650	
60	580	
80	500	
100	420	
120	400	

AC ELECTRICAL CHARACTERISTICS

PARAMETER	SYMBOL	TEST CONDITIONS	MIN	TYP	MAX	UNIT
Rise time	(t _r)	RL=100 (5w) CL=20pF (Fig1)			10	uS
Fall time	(t _f)	RL=100 (5w) CL=20pF (Fig1)			300	nS

MAGNETIC CHARACTERISTICS

FS210LF-A		Ta= -20 °C +100 °C	
PARAMETER	MIN	MAX	UNIT
Bop	+10	+65	G
Brp	-65	-10	G
Bhys	20	130	G

FS210LF-B		Ta= -20 °C +100 °C	
PARAMETER	MIN	MAX	UNIT
Bop	+5	+80	G
Brp	-80	-5	G
Bhys	10	160	G

FS210LF-Bu		Ta= -20 °C +100 °C	
PARAMETER	MIN	MAX	UNIT
Bop		+80	G
Brp	-80		G
Bhys		160	G

FS210LF-C		Ta= -20 °C +100 °C	
PARAMETER	MIN	MAX	UNIT
Bop		+100	G
Brp	-100		G
Bhys		200	G

FS210 HYSTERESIS CHARACTERISTICS

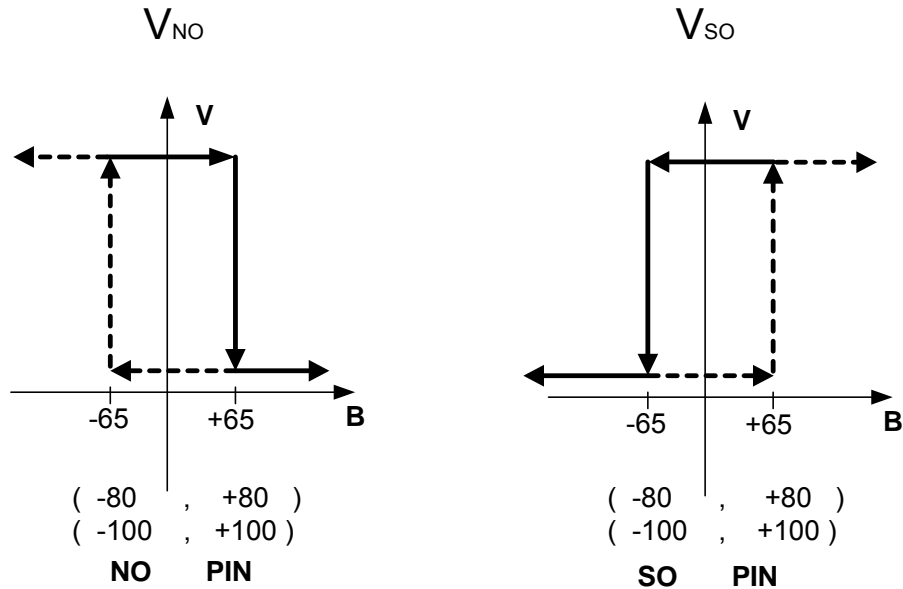

TEST CIRCUITS:

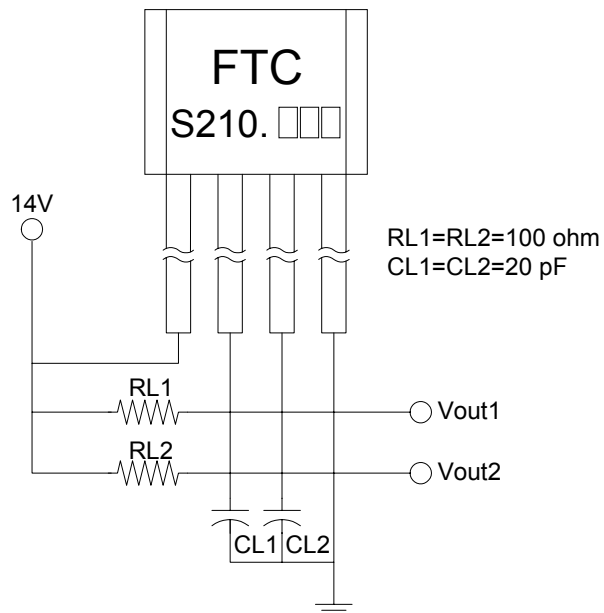

Fig 1

TYPICAL CHARACTERISTICS

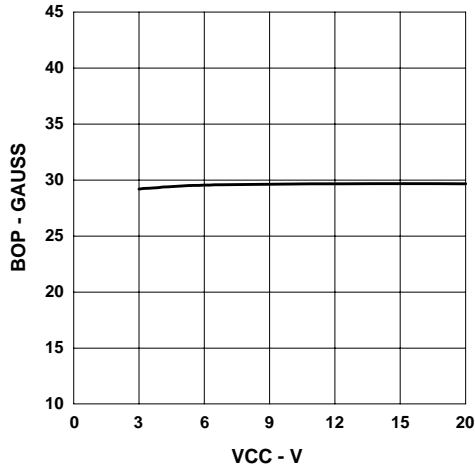

Figure 1

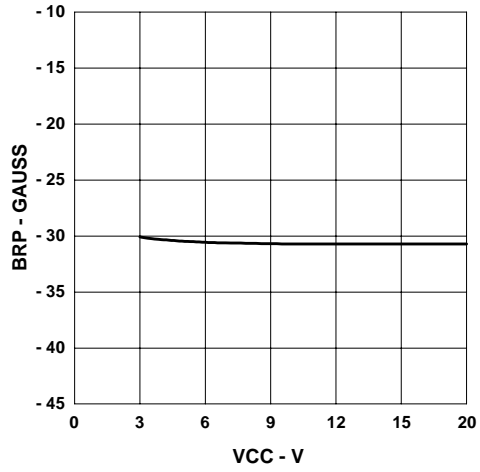

Figure 2

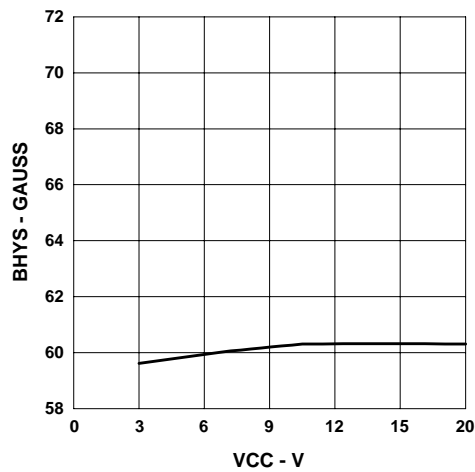

Figure 3

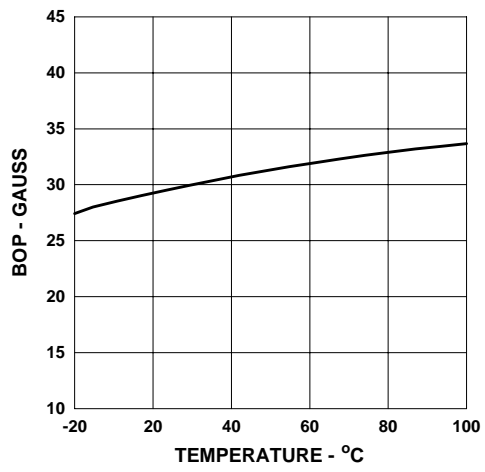

Figure 4

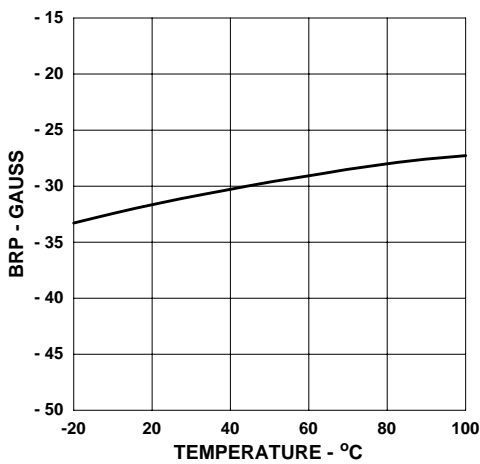

Figure 5

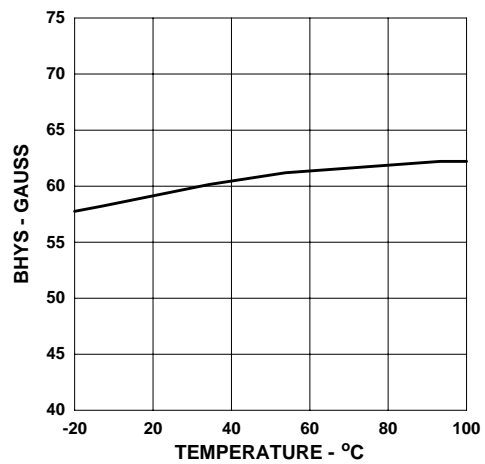

Figure 6

FUNCTION DESCRIPTIONS

HALL SENSOR LOCATION

The Fig 2 is the hall sensor location, where marks the IC number. The best sensitivity, which can be intensified as much as possible, depends on the vertical distance and position between magnetic pole and the hall sensor (Fig 3). For the single-phase motor, this design is very important.

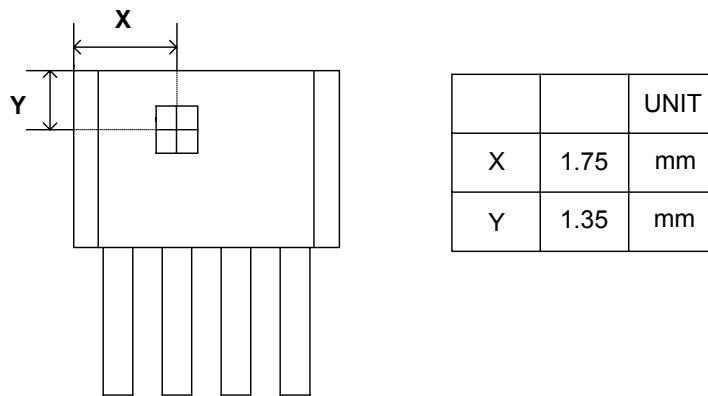

Fig 2. FS210 Hall Sensor Location

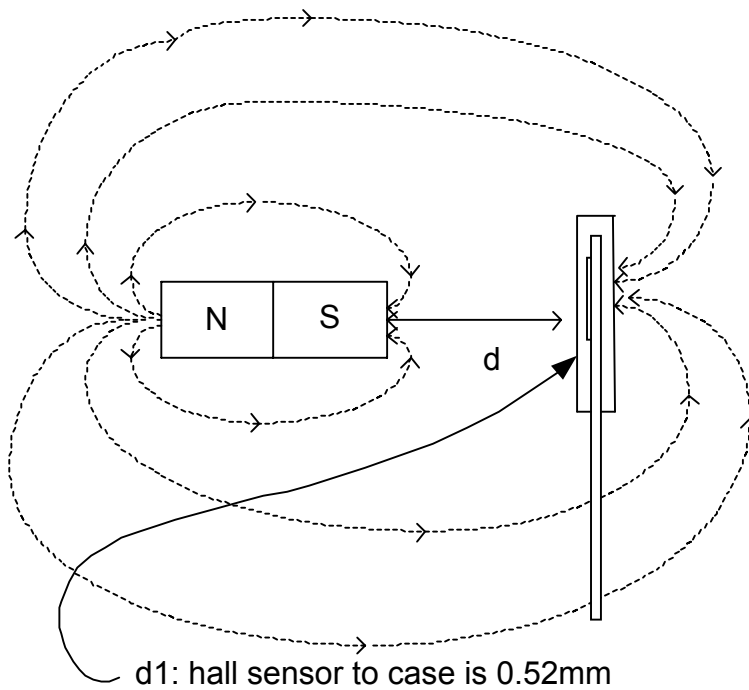

Fig 3. Magnetic Distribution and Z-axis position

APPLICATION NOTE

The Example of Typical Application Circuit

Fig 5 is the example of typical application circuit. The red, yellow, and black wires are the input points of the motor system: red, the input of power supply; yellow, the output of FG; black, the ground signal. R_C is an external pull-up resistance for the use of measuring FG signal. In view of the design, the value of R_C could be decided by the transistor saturation voltage (V_{ON}), sink current (I_C), and off-level voltage (V_C).

The formula is:
$$R_C = \frac{V_C - V_{ON}}{I_C}$$

For example:

$V_C = +5V$ for TTL level.

$I_C = 10mA$ at 0.2V saturation voltage

The safety value of $R_C = 470$

D1 is the reverse protection diode. As if the red and black wires reversely connect with the power source, the current will flow through the ground via IC and coils L1 and L2 to power supply. Under such kind of circumstances, the IC and coils are easy to be burned out. Therefore, D1, the reverse protection diode, is necessary for the design. However, D1 will also cause an extra voltage drop on the supply voltage.

C1 is a capacitor to reduce the ripple noise caused during the transient of the output stages. The volume of the ripple noise depends on the coil impedance and characteristics.

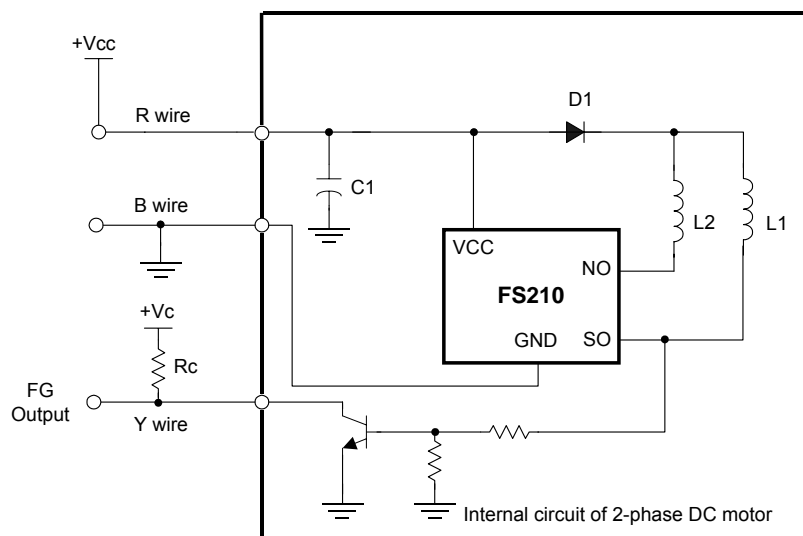
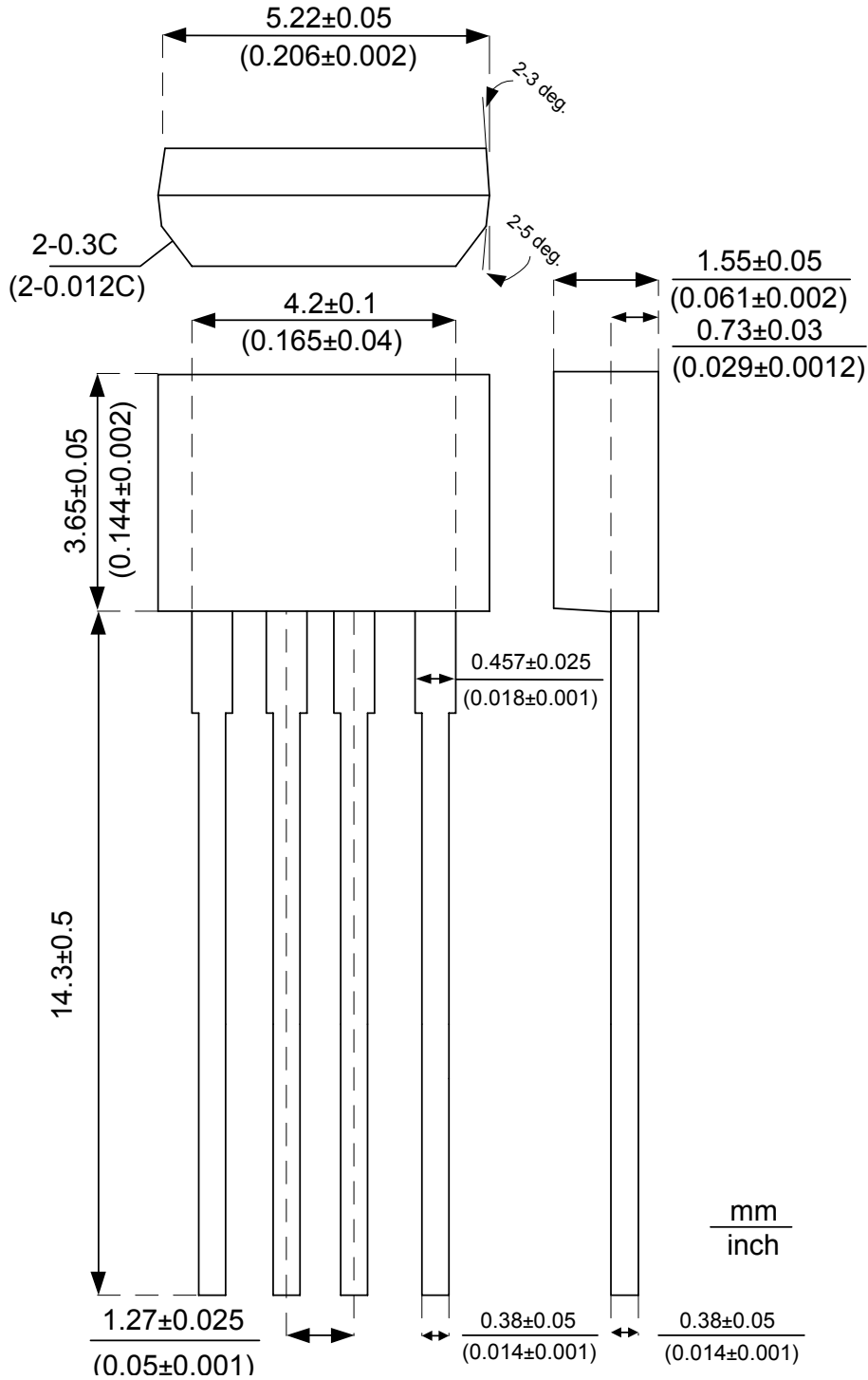

Fig 5. Application Circuit

PACKAGE OUTLINE (LEAD FREE)



PACKING SPECIFICATIONS

BAG & BOX DIMENSION

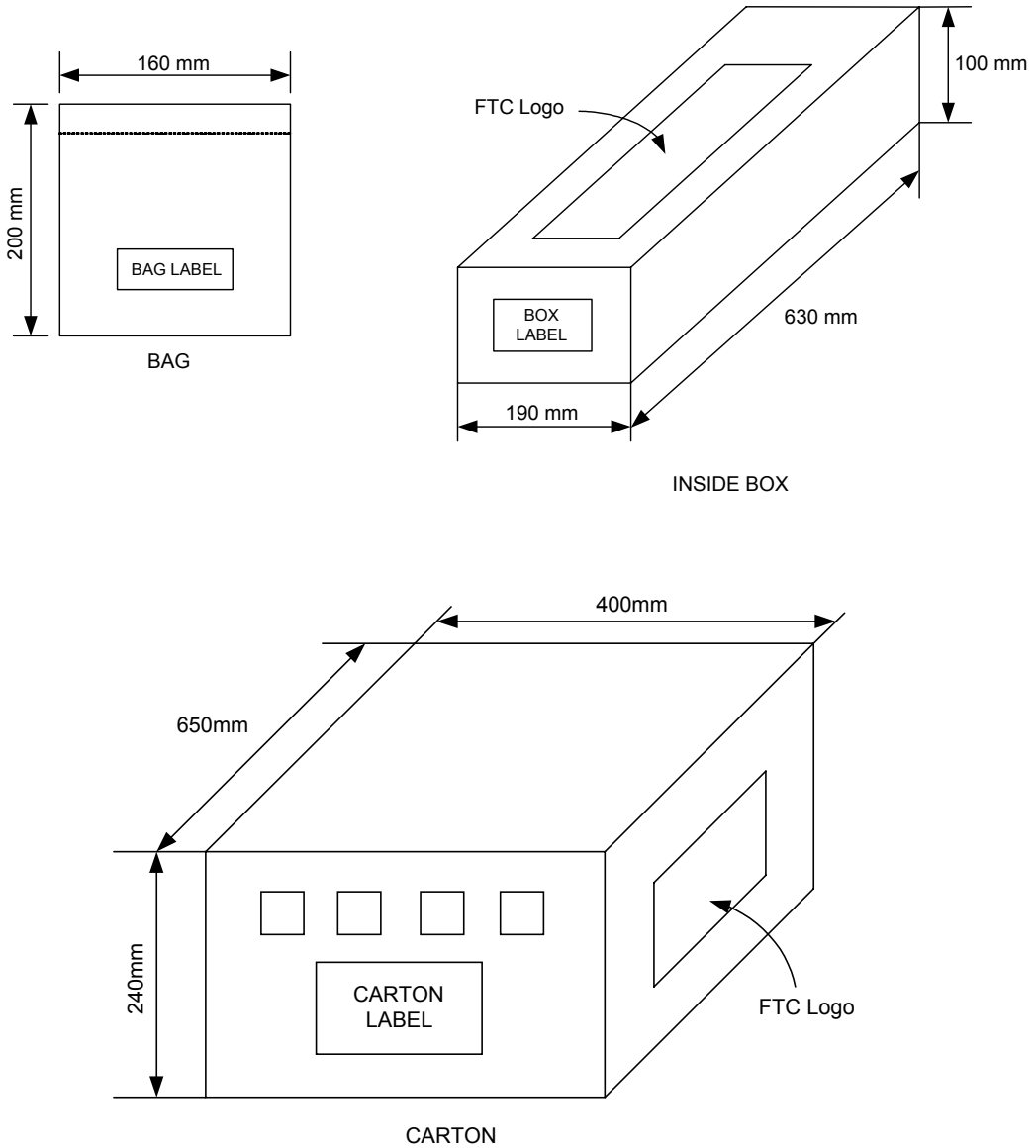

PACKING QUANTITY SPECIFICATIONS

1000 EA / 1 BAG

25 BAGS / 1 INSIDE BOX

4 INSIDE BOXES / 1 CARTON

LABEL SPECIFICATIONS

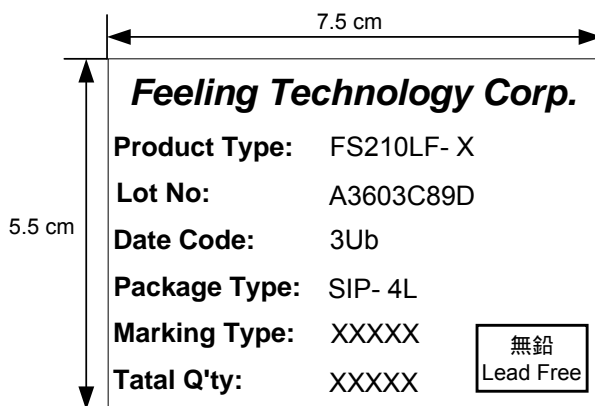

BAG LABEL, INSIDE BOX & CARTON LABEL

ORDER INFORMATION

Part Number	Operating Temperature	Package	Description
FS210LF-A	-20 °C +100 °C	TO-92SP-4	±65G (B)
FS210LF-B	-20 °C +100 °C	TO-92SP-4	±80G (B)
FS210LF-Bu	-20 °C +100 °C	TO-92SP-4	±80G (B)
FS210LF-C	-20 °C +100 °C	TO-92SP-4	±100G (B)