

MSF4N60L

600V N-Channel MOSFET

Description

The MSF4N60L is a N-channel enhancement-mode MOSFET, providing the designer with the best combination of fast switching, ruggedized device design, low on-resistance and cost effectiveness. The TO-220F package is universally preferred for all commercial-industrial applications

Features

- Low On Resistance
- Simple Drive Requirement
- Low Gate Charge
- Fast Switching Characteristic
- RoHS compliant package

Application (500V-600V)

- Open Framed Power Supply
- Adapter
- STB

Packing & Order Information

50/Tube ; 1,000/Box



**RoHS
COMPLIANT**

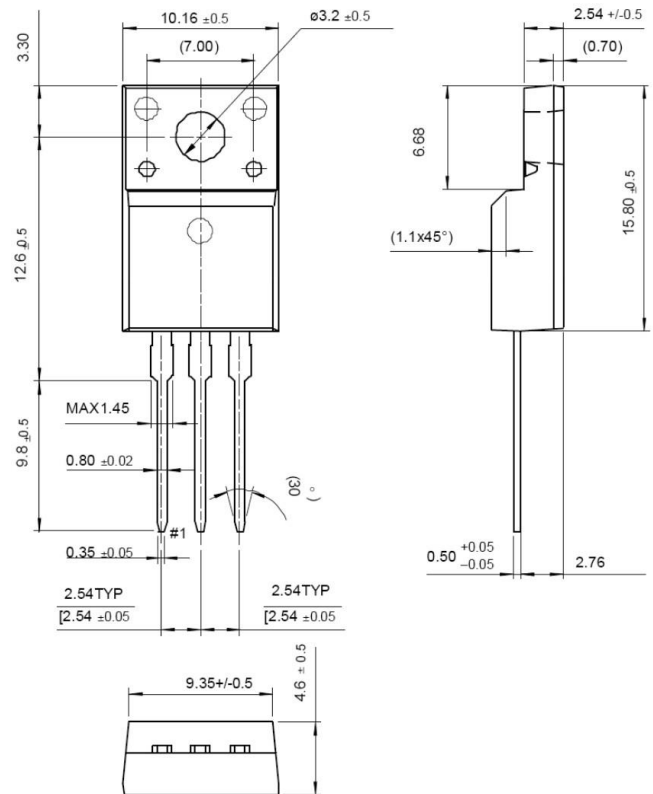

Graphic symbol

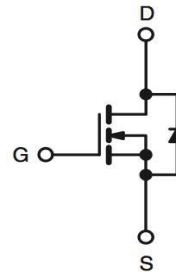

MAXIMUM RATINGS AND ELECTRICAL CHARACTERISTICS

Absolute Maximum Ratings

Symbol	Parameter	Value	Unit
V _{DSS}	Drain-Source Voltage	600	V
V _{GS}	Gate-Source Voltage	±30	V
I _D	Drain Current -Continuous (TC=25°C)	4.5	A
	Drain Current -Continuous (TC=100°C)	2.6	A
I _{DM}	Drain Current Pulsed	18	A
I _{AR}	Avalanche Current	4.0	A
E _{AS}	Single Pulsed Avalanche Energy	48	mJ
E _{AR}	Repetitive Avalanche Energy	3.1	mJ
dv/dt	Peak Diode Recovery dv/dt	4.5	V/ns

MSF4N60L

600V N-Channel MOSFET

Absolute Maximum Ratings

Symbol	Parameter	Value	Unit
T_L	Maximum lead temperature for soldering purposes, 1/8" from case for 5 seconds	300	°C
TPKG	Maximum Temperature for Soldering @ Package Body for 10 seconds	260	°C
P_D	Total Power Dissipation ($T_C = 25\text{ °C}$)	31	W
	Derating Factor above 25 °C	0.25	W/°C
T_{STG}	Operating and Storage Temperature Range	-55 to +150	°C
T_J	Storage Temperature	150	°C

Notes;

1. Repetitive Rating: Pulse width limited by maximum junction temperature
2. $I_{AS}=4A$, $V_{DD}=50V$, $L=7mH$, $V_G=10V$, Starting $T_J=25\text{ °C}$
3. $I_{SD}\leq 4A$, $di/dt\leq 200A/\mu s$, $V_{DD}\leq BV_{DSS}$, Starting $T_J=25\text{ °C}$

Thermal Characteristics ($T_c=25\text{ °C}$ unless otherwise noted)

Symbol	Parameter	Max.	Units
$R_{\theta JC}$	Thermal Resistance, Junction-to-Case	2.6	°C/W
$R_{\theta JA}$	Thermal Resistance, Junction-to-Ambient	62.5	

Static Characteristics

Symbol	Parameter	Test Conditions	Min	Typ.	Max.	Units
BV_{DSS}	Drain-Source Breakdown Voltage	$V_{GS} = 0\text{ V}$, $I_D = 250\mu A$	600	--	--	V
$\Delta BV_{DSS} / \Delta T_J$	Breakdown Voltage Temperature Coefficient	$I_D = 250\mu A$, Referenced to 25°C	--	0.6	--	V/°C
$V_{GS(th)}$	Gate Threshold Voltage	$V_{DS} = V_{GS}$, $I_D = 250\mu A$	2.0	--	4.0	V
I_{DSS}	Zero Gate Voltage Drain Current	$V_{DS} = 600\text{ V}$, $V_{GS} = 0\text{ V}$ $V_{DS} = 480\text{ V}$, $T_C = 125\text{ °C}$	--	--	1 10	μA
I_{GSS}	Gate-Body Leakage Forward	$V_{GS} = \pm 30$	--	--	± 100	nA
$R_{DS(ON)}$	Static Drain-Source On-Resistance	$V_{GS} = 10\text{ V}$, $I_D = 3.5\text{ A}$	--	0.9	1.4	Ω

Dynamic Characteristics

Symbol	Parameter	Test Conditions	Min	Typ.	Max.	Units
C_{ISS}	Input Capacitance	$V_{DS} = 25\text{ V}$, $V_{GS} = 0\text{ V}$, $f = 1.0\text{ MHz}$	--	1482	--	pF
C_{OSS}	Output Capacitance		--	121.7	--	pF
C_{RSS}	Reverse Transfer Capacitance		--	14	--	pF

MSF4N60L

600V N-Channel MOSFET

Dynamic Characteristics						
Symbol	Parameter	Test Conditions	Min	Typ.	Max.	Units
$t_{d(on)}$	Turn-On Time	$V_{DS} = 300\text{ V}, I_D = 7\text{ A},$ $R_G = 25\ \Omega, V_{GS} = 10\text{ V}$	--	10	30	ns
t_r	Turn-On Time		--	40	80	ns
$t_{d(off)}$	Turn-Off Delay Time		--	40	100	ns
t_f	Turn-Off Fall Time		--	50	90	ns
Q_g	Total Gate Charge	$V_{DS} = 300\text{ V}, I_D = 7\text{ A},$ $V_{GS} = 10\text{ V}$	--	28	37	nC
Q_{gs}	Gate-Source Charge		--	4.7	--	nC
Q_{gd}	Gate-Drain Charge		--	11	--	nC

Source-Drain Diode						
Symbol	Parameter	Test Conditions	Min	Typ.	Max.	Units
I_S		$V_D = V_G = 0$	--	--	4.0	A
I_{SM}		$V_S = 1.3\text{ V}$	--	--	16	
V_{SD}		$I_S = 4\text{ A}, V_{GS} = 0\text{ V}$	--	0.85	1.0	V
t_{rr}		$I_F = 7\text{ A}, V_{GS} = 0\text{ V}$	--	350	--	ns
Q_{rr}		$diF/dt = 100\text{ A}/\mu\text{s}$	--	3.3	--	μC

Notes;

1. Pulse Test: Pulse Width $\leq 300\mu\text{s}$, Duty Cycle $\leq 2\%$

MSF4N60L

600V N-Channel MOSFET

■ Characteristics Curve

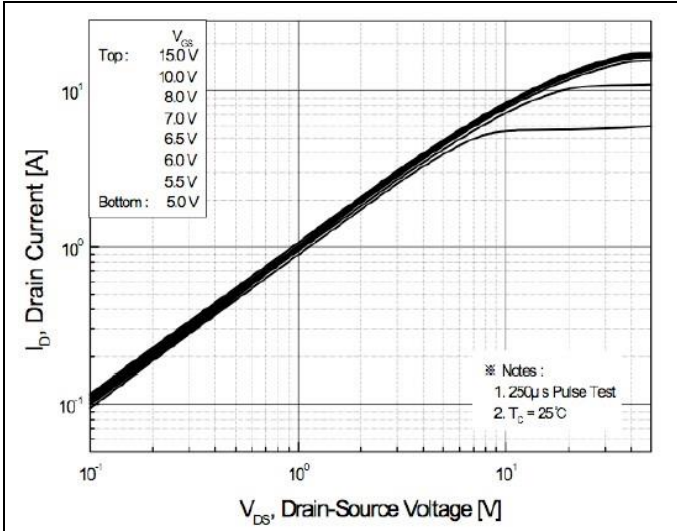

FIG.1-ON REGION CHARACTERISTICS

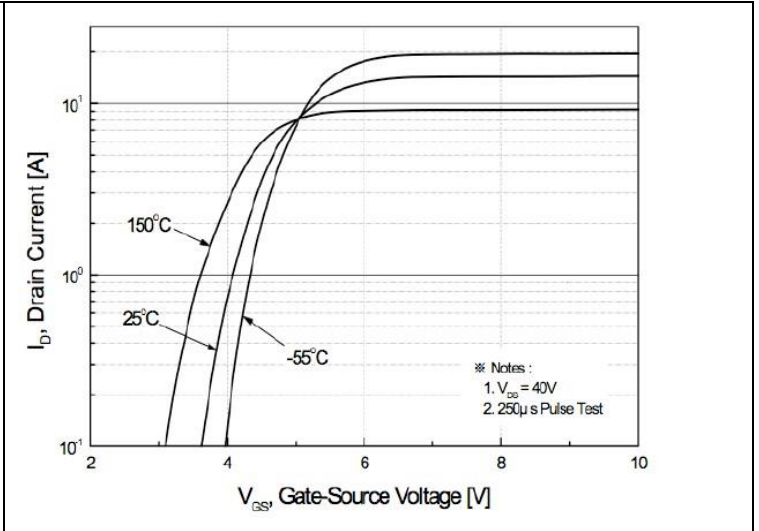

FIG.2-TRANSFER CHARACTERISTICS

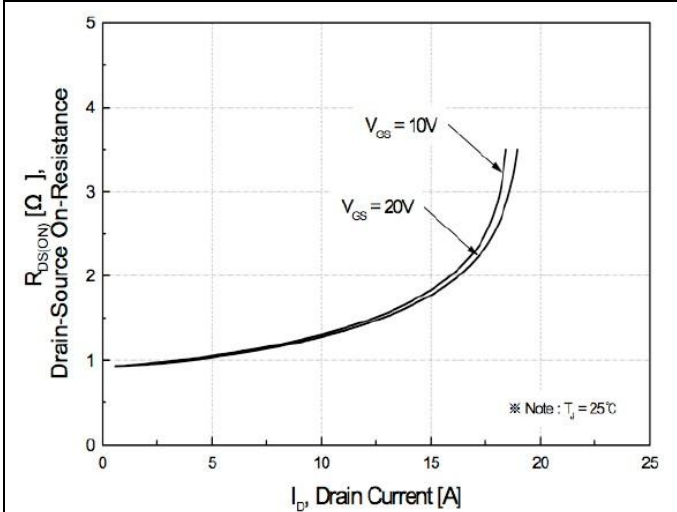

FIG.3-ON RESISTANCE VARIATION VS DRAIN CURRENT AND GATE VOLTAGE

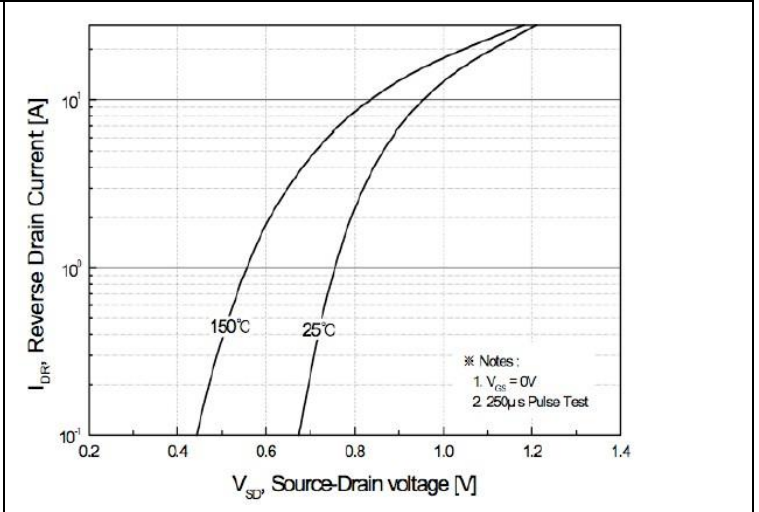

FIG.4-BODY DIODE FORWARD VOLTAGE VARIATION WITH SOURCE CURRENT AND TEMPERATURE

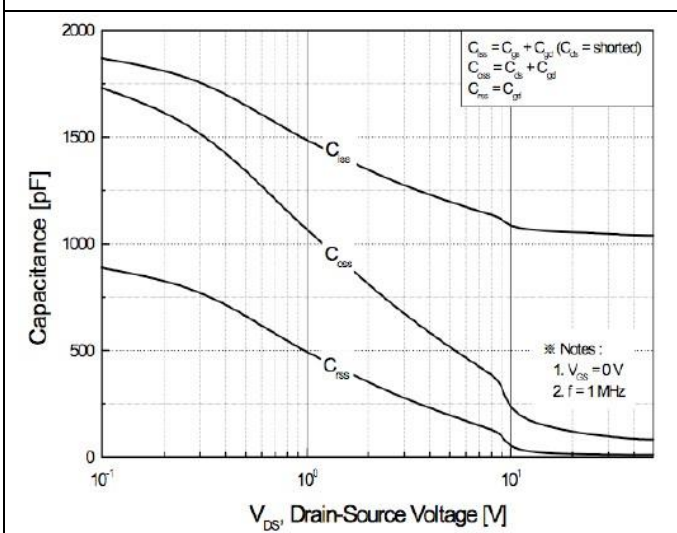

FIG.5-CAPACITANCE CHARACTERISTICS

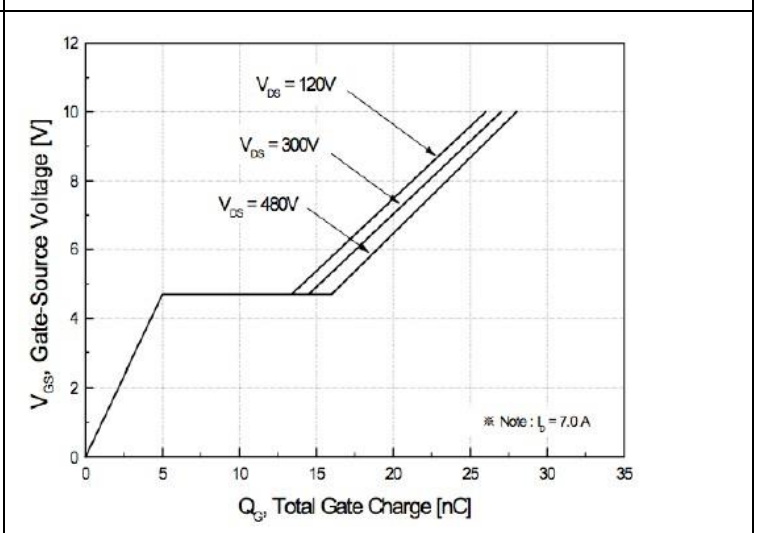

FIG.6-GATE CHARGE CHARACTERISTICS

MSF4N60L

600V N-Channel MOSFET

■ Characteristics Curve

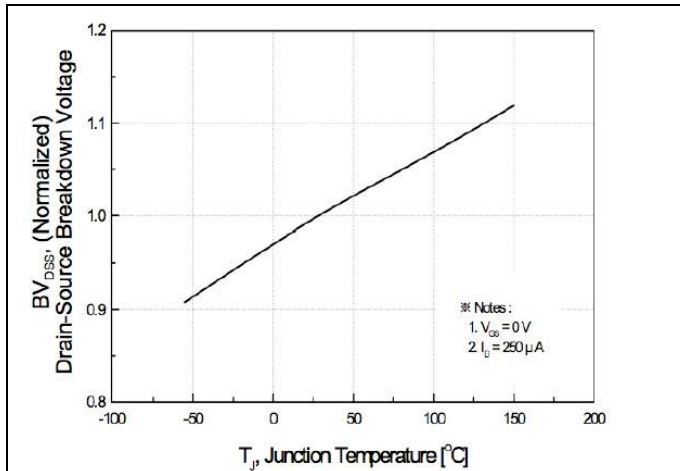

FIG.7-BREAKDOWN VOLTAGE VARIATION VS TEMPERATURE

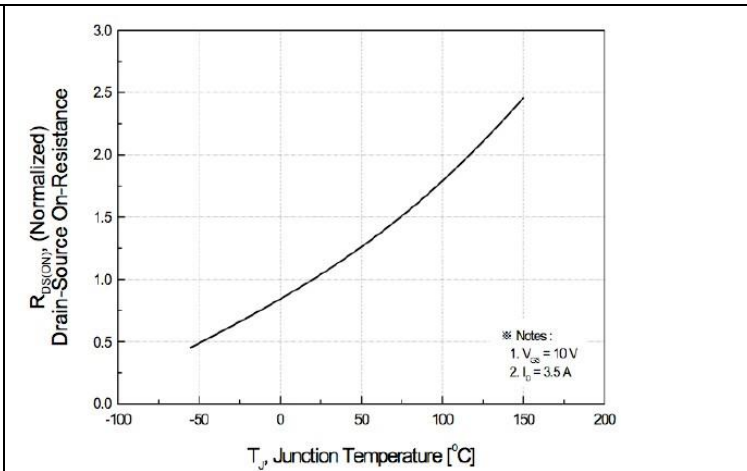

FIG.8-ON-RESISTANCE VARIATION VS TEMPERATURE

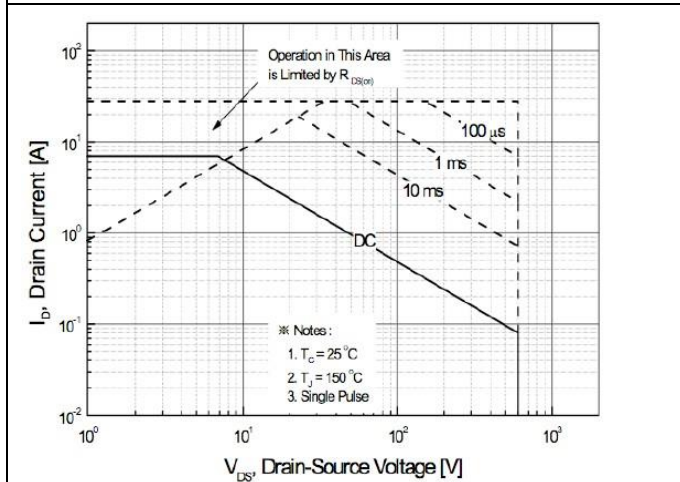

FIG.9-MAXIMUM SAFE OPERATING AREA

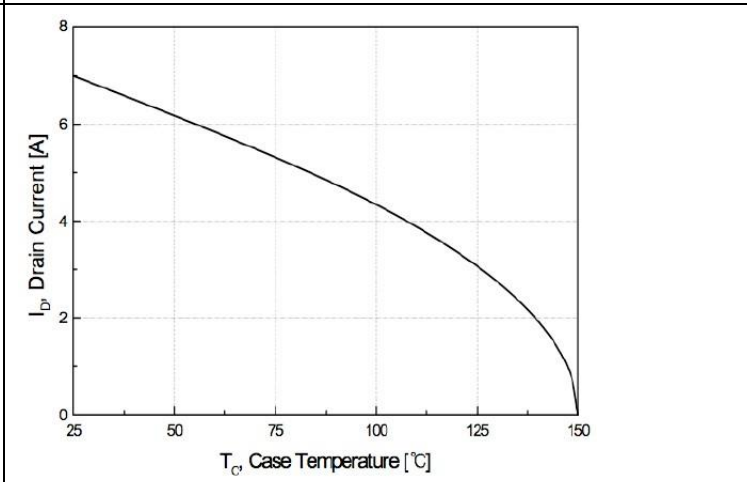

FIG.10-MAXIMUM DRAIN CURRENT VS CASE TEMPERATURE

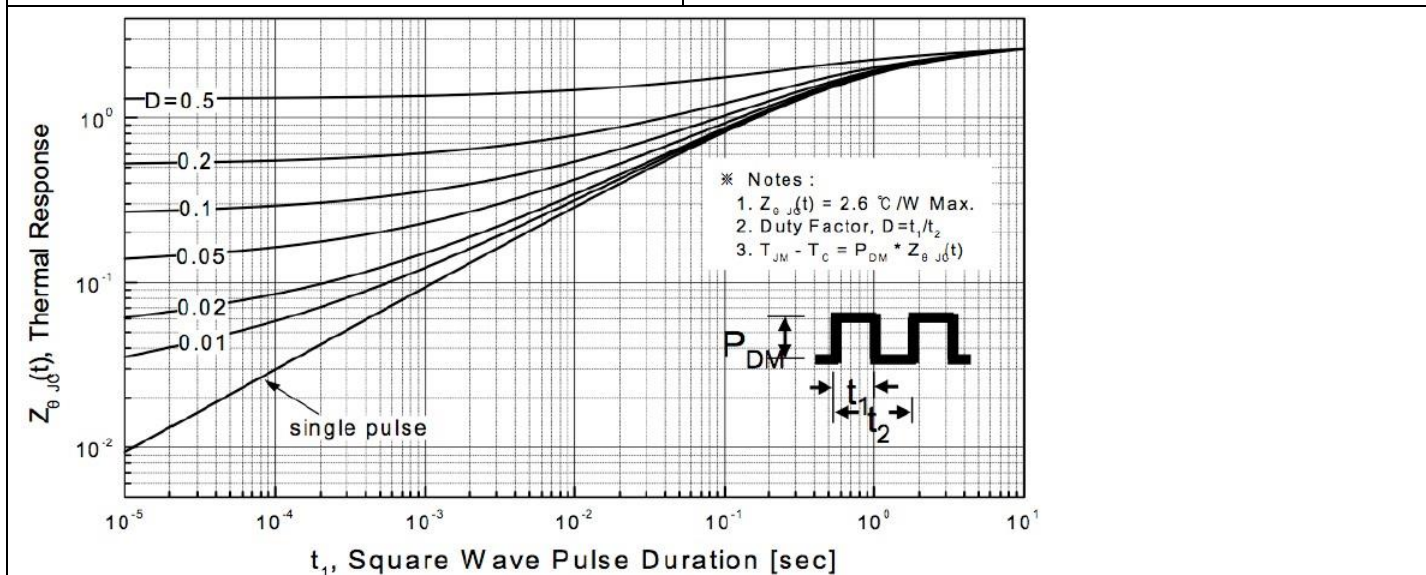

FIG.11-TRANSIENT THERMAL RESPONSE CURVE

MSF4N60L

600V N-Channel MOSFET

■ Characteristics Test Circuit & Waveform

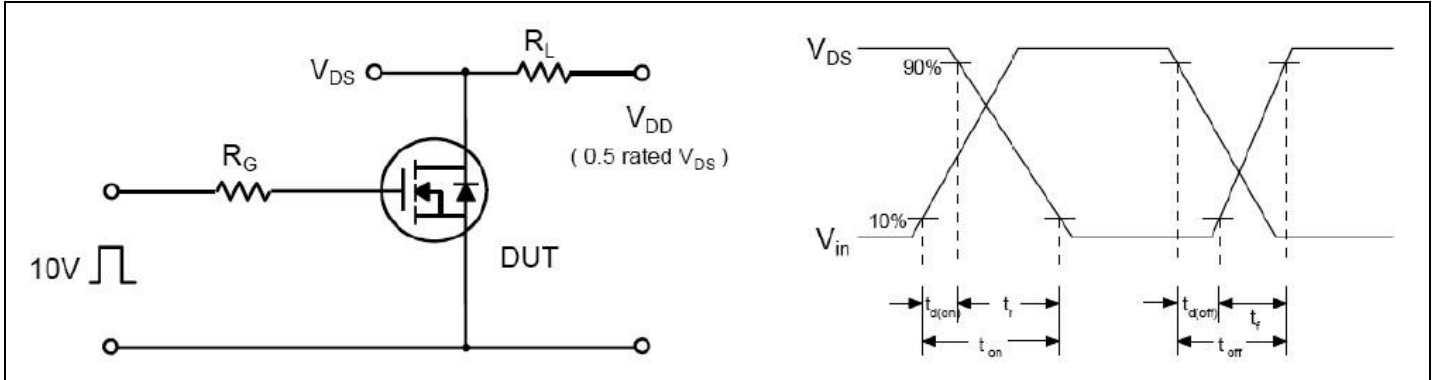

Fig 12. Resistive Switching Test Circuit & Waveforms

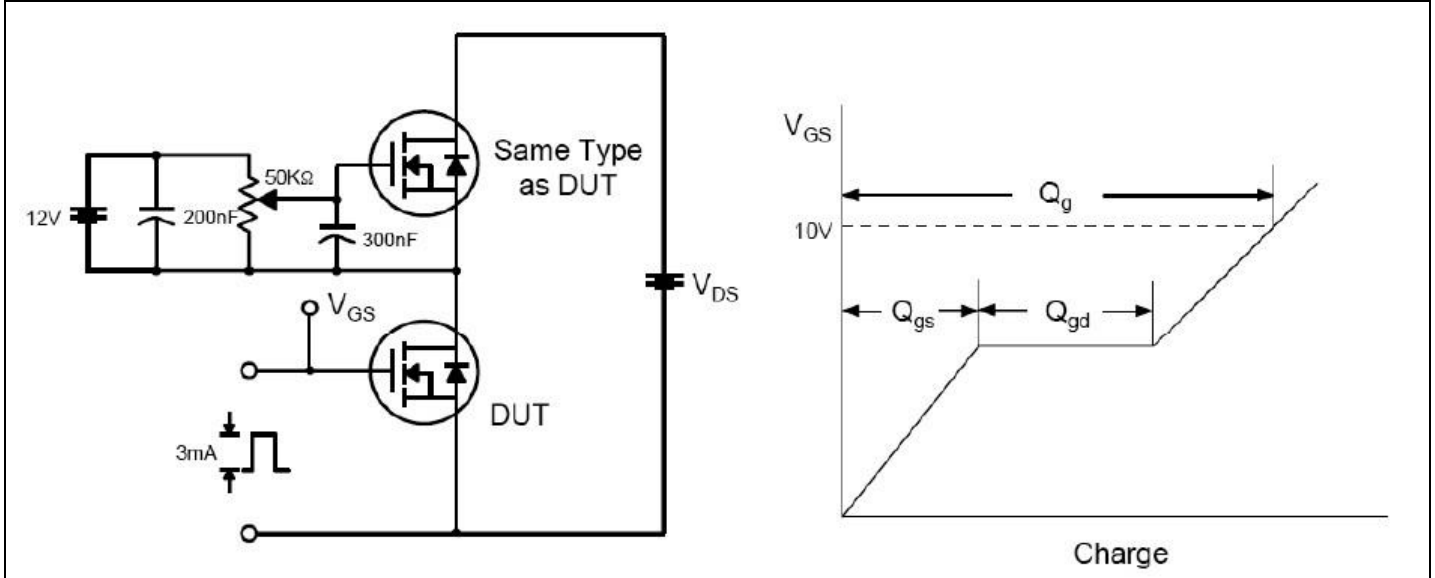

Fig 13. Gate Charge Test Circuit & Waveform

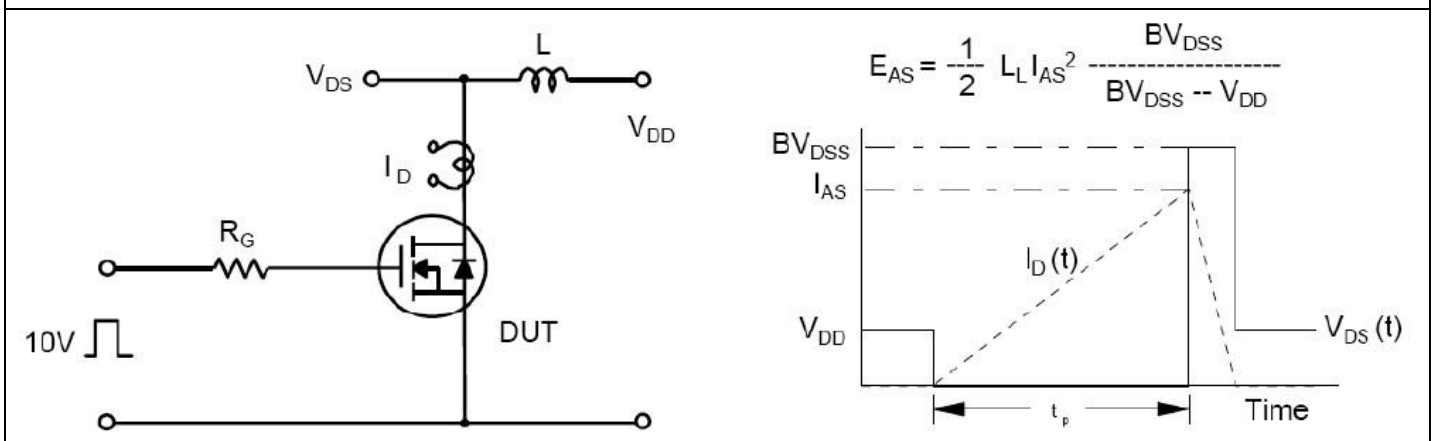

Fig 14. Unclamped Inductive Switching Test Circuit & Waveforms

MSF4N60L

600V N-Channel MOSFET

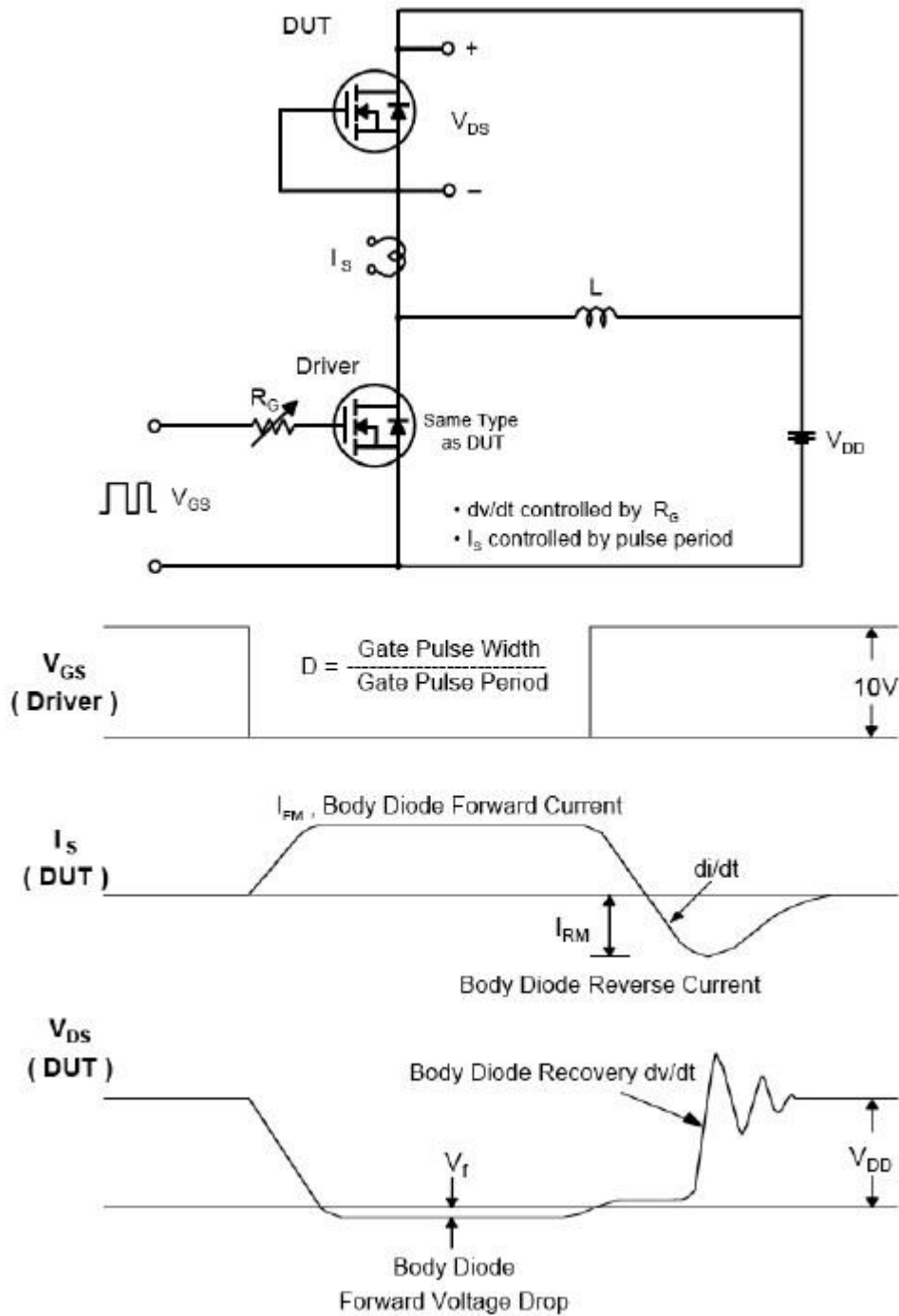

Fig 15. Peak Diode Recovery dv/dt Test Circuit & Waveforms

MSF4N60L

600V N-Channel MOSFET

Disclaimer

ALL PRODUCT, PRODUCT SPECIFICATIONS AND DATA ARE SUBJECT TO CHANGE WITHOUT NOTICE TO IMPROVE RELIABILITY, FUNCTION OR DESIGN OR OTHERWISE.

Bruckewell Technology Inc., its affiliates, agents, and employees, and all persons acting on its or their behalf (collectively, "Bruckewell"), disclaim any and all liability for any errors, inaccuracies or incompleteness contained in any datasheet or in any other disclosure relating to any product.

Bruckewell makes no warranty, representation or guarantee regarding the suitability of the products for any particular purpose or the continuing production of any product. To the maximum extent permitted by applicable law, Bruckewell disclaims

- (i) Any and all liability arising out of the application or use of any product.
- (ii) Any and all liability, including without limitation special, consequential or incidental damages.
- (iii) Any and all implied warranties, including warranties of fitness for particular purpose, non-infringement and merchantability.

Statements regarding the suitability of products for certain types of applications are based on Bruckewell's knowledge of typical requirements that are often placed on Bruckewell products in generic applications.

Such statements are not binding statements about the suitability of products for a particular application. It is the customer's responsibility to validate that a particular product with the properties described in the product specification is suitable for use in a particular application. Parameters provided in datasheets and/or specifications may vary in different applications and performance may vary over time.

Product specifications do not expand or otherwise modify Bruckewell's terms and conditions of purchase, including but not limited to the warranty expressed therein.