

FEMALE STRAIGHT PLUG SOLDER TYPE

R222.052.000

CABLE .085

Series : SMP

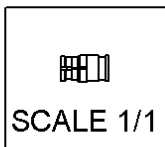
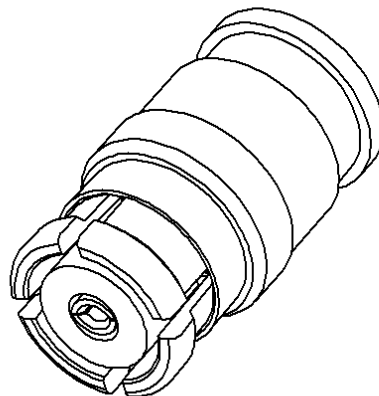
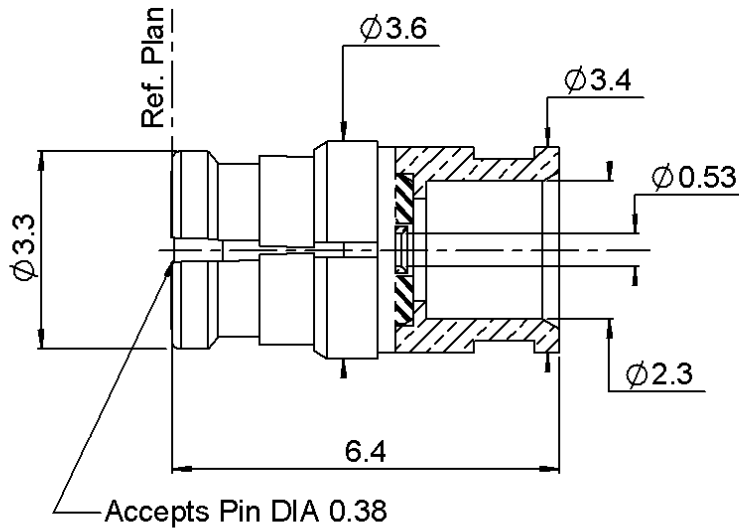

All dimensions are in mm.

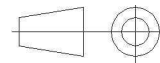

COMPONENTS	MATERIALS	PLATINGS (µm)
BODY	BERYLLIUM COPPER	GOLD 1.3 OVER NICKEL2
CENTER CONTACT	BERYLLIUM COPPER	GOLD 1.27 OVER NICKEL 1.27
OUTER CONTACT	-	-
INSULATOR	PTFE	-
GASKET	-	-
OTHERS PARTS	BERYLLIUM COPPER	GOLD 1.3 OVER NICKEL2
-	-	-
-	-	-

Issue : 0924 C

In the effort to improve our products, we reserve the right to make changes judged to be necessary.



FEMALE STRAIGHT PLUG SOLDER TYPE

R222.052.000

CABLE .085

Series : SMP

PACKAGING

Standard	Unit	Other
100	'W' option	Contact us

SPECIFICATION

CABLE ASSEMBLY

ELECTRICAL CHARACTERISTICS

Stripping	a	b	c	d	e	f
mm	1,30	0,00	0,00	0,00	0,00	0,00

Impedance	50	Ω
Frequency	0-40	GHz
VSWR	1.35 + 0,0000	x F(GHz) Maxi
Insertion loss	0.12	\sqrt{F} (GHz) dB Maxi
RF leakage	- (- F(GHz) dB mini
Voltage rating	335	Veff Maxi
Dielectric withstanding voltage	500	Veff mini
Insulation resistance	5000	M Ω mini

Assembly instruction :

Recommended cable(s)

KS 1
RG 405

Cable retention

- pull off **200** N mini
- torque **NA** N.cm

MECHANICAL CHARACTERISTICS

TOOLING

Center contact retention		
Axial force – Mating end	NA	N mini
Axial force – Opposite end	NA	N mini
Torque	NA	N.cm mini

Part Number	Description	Hexagon
.	.	.
R282.051.000	STRIPPING TOOL	
R282.062.010	POINTER GAUGE	
R282.740.030	SOLDERING MOUNTING	
R282.743.120	POSITIONER FOR SOLDERING SMP	
R282.744.253	POSITIONER FOR SOLDERING SMP	
R282.862.050	SOLDER GAUGE THCK .012	

Recommended torque		
Mating	NA	N.cm
Panel nut	NA	N.cm
Clamp nut	NA	N.cm
A/F clamp nut	0,0000	mm

Mating life	100	Cycles mini
Weight	0,0900	g

OTHERS CHARACTERISTICS

ENVIRONMENTAL

RF leakage:-80dB DC-3GHz
-65dB 3-26.5GHz
Compliant with MIL-STD-348

Operating temperature	-65/+165	$^{\circ}$ C
Hermetic seal	NA	Atm.cm3/s
Panel leakage	NA	

Issue : 0924 C

In the effort to improve our products, we reserve the right to make changes judged to be necessary.



FEMALE STRAIGHT PLUG SOLDER TYPE

R222.052.000

CABLE .085

Series : SMP

COMPONENTS

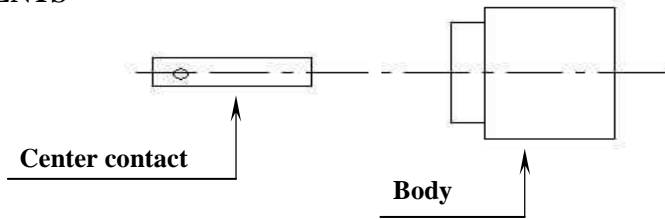

STRIPPING CABLES

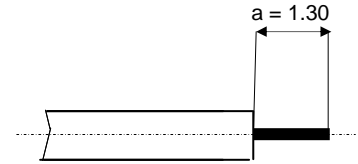

We recommend a thermal preconditioning cable

1

Strip the dielectric of the cable .
Trim the cable.
Clean the cable .
Iron temperature not exceed 250°C

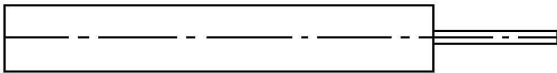

2

Screw the positioner onto the soldering jig.
Slide center contact into positioner.
Insert solder gauge between contact and cable .
Tighten and solder the contact.

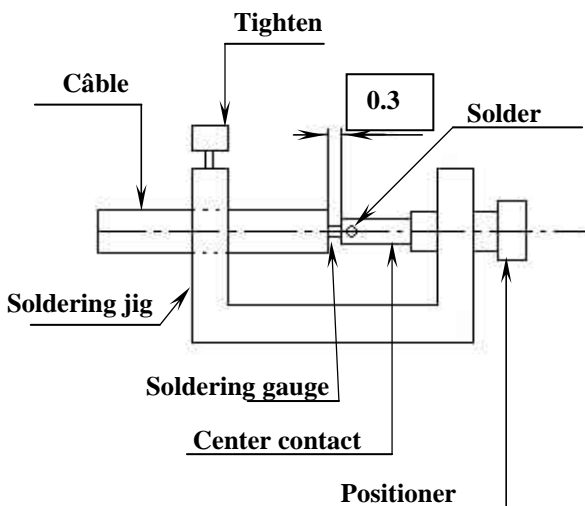

3

After cooling remove cable assembly from the jig.
Slide body into positioner .
Slide cable into the connector until it bottoms against the positioner .
Tighten.
Solder the body onto the cable.
After cooling remove cable assembly from the jig.

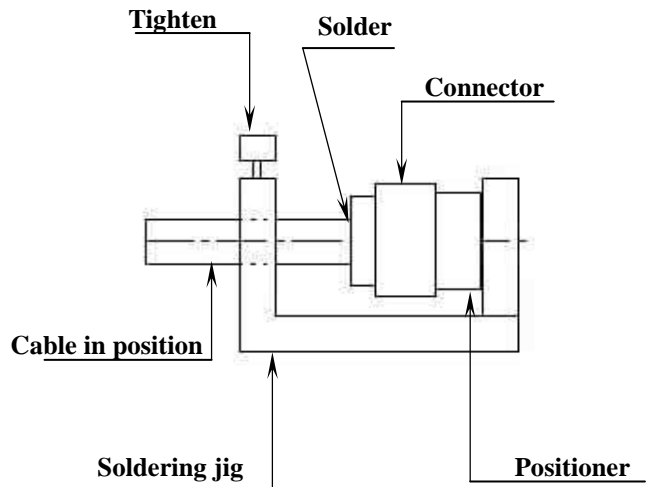

Issue : 0924 C

In the effort to improve our products, we reserve the right to make changes judged to be necessary.