

## 8CH Darlingtion Sink Driver

**IK62083/4**

The IK62083~IK62084 are high-voltage, high-current darlington drivers comprised of eight NPN darlington pairs.

All units feature integral clamp diodes for switching inductive loads.

Application include relay, hammer, lamp and display (LED) drivers.

### Features

- Output current (single output) 500mA (Max)
- Output clamp diodes
- Inputs compatible with various types of logic

TYPE	INPUT BASE RESISTOR	DESIGNATION
IK62083N/DW	2.7kΩ	TTL, 5V CMOS
IK62084N/DW	10.5kΩ	6~15V PMOS, CMOS

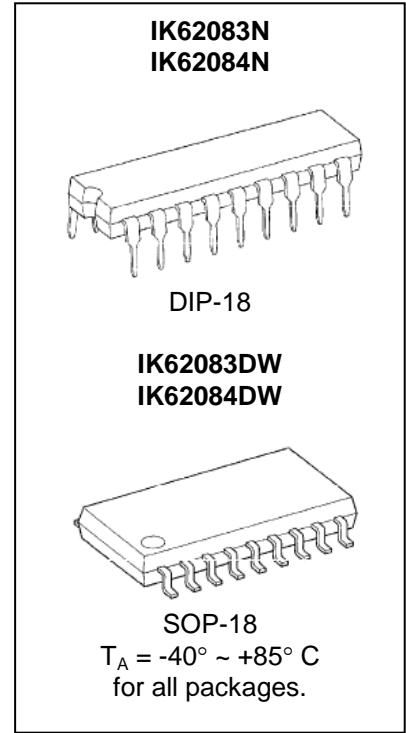

### Pin Configuration (top view)

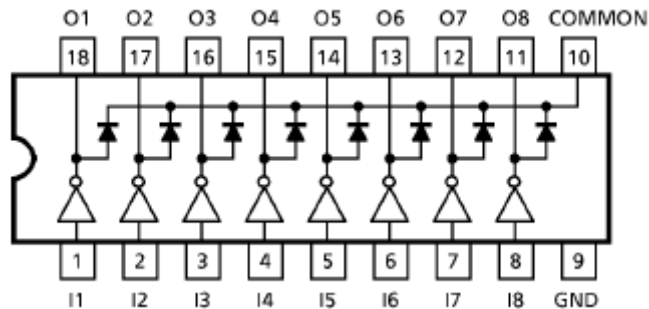

### Block Schematics

IK62083

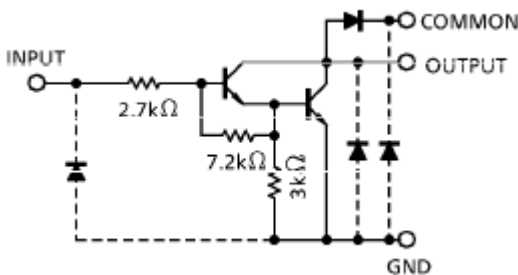

IK62084

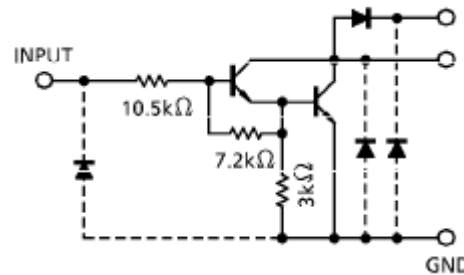

Note: The input and output parasitic diodes cannot be used as clamp diodes.

**Absolute Maximum Ratings**

Ta =25°C

Parameter	Symbol	Limit Values		Unit
		min.	max.	
Output Sustaining Voltage	V <sub>CE(SUS)</sub>	-0.5	50	V
Output Current	I <sub>OUT</sub>	500		mA/ch
Input Voltage	V <sub>IN</sub>	- 0.5	30	V
Clamp Diode Reverse Voltage	V <sub>R</sub>	50		V
Clamp Diode Forward Current	I <sub>F</sub>	500		mA
Power Dissipation	IK62083N	1.47		W
	IK62083DW	0.96		
Operating Temperature	T <sub>opr</sub>	-40	85	°C
Storage Temperature	T <sub>stg</sub>	-55	150	°C

\* Stresses beyond those listed under “absolute maximum ratings” may cause permanent damage to the device. These are stress ratings only and functional operation of the device at these or any other conditions beyond those indicated under “recommended operating conditions” is not implied. Exposure to absolute-maximum-rated conditions for extended periods may affect device reliability.

**Recommended Operating Conditions**

(Ta=-40~85°C)

Parameter	Symbol	Test Condition	Limit Value			Unit
			Min	Typ	Max	
Output Sustaining Voltage	V <sub>CE(SUS)</sub>		0	-	50	V
Output Current	I <sub>OUT</sub>	N T <sub>pw</sub> =25ms,Duty=10%, 8 Circuits	0	-	347	mA/ch
			0	-	123	
		DW T <sub>pw</sub> =25ms,Duty=10%, 8 Circuits	0	-	268	
			0	-	90	
Input Voltage	V <sub>IN</sub>		0	-	30	V
Input Voltage (Output On)	IK62083N/DW	V <sub>IN(ON)</sub>	3.5	-	30	V
	IK62084N/DW		8	-	30	
Clamp Diode Reverse Voltage	V <sub>R</sub>		-	-	50	V
Clamp Diode Forward Current	I <sub>F</sub>		-	-	400	mA
Power Dissipation	N	P <sub>D</sub>	-	-	0.52	W
	DW		-	-	0.4	

## Electrical Characteristics

Ta = 25°C

Parameter		Symbol	Test Circuit	Test Condition	Limit Values			Unit	
					Min	Typ	Max		
Output Leakage Current	IK62083	I <sub>CEX</sub>	1	V <sub>CE</sub> =50V	Ta=25°C	-	-	50	uA
				V <sub>CE</sub> =50V	Ta=85°C	-	-	100	
	IK62084			V <sub>CE</sub> =50V	V <sub>IN</sub> =1V	-	-	500	
Collector-Emitter Saturation Voltage		V <sub>CE(sat)</sub>	2	I <sub>OUT</sub> =350mA, I <sub>IN</sub> =500uA		-	1.3	1.6	V
				I <sub>OUT</sub> =200mA, I <sub>IN</sub> =350uA		-	1.1	1.3	
				I <sub>OUT</sub> =100mA, I <sub>IN</sub> =250uA		-	0.9	1.1	
Input Current	IK62083	I <sub>IN(ON)</sub>	2	V <sub>IN</sub> =3.85V		-	0.93	1.35	mA
	IK62084			V <sub>IN</sub> =5V		-	0.35	0.5	
				V <sub>IN</sub> =12V		-	1.0	1.45	
Input Voltage (Output On)	IK62083	V <sub>IN(ON)</sub>	5	V <sub>CE</sub> =2V, I <sub>OUT</sub> =200mA		-	-	2.4	V
				V <sub>CE</sub> =2V, I <sub>OUT</sub> =250mA		-	-	2.7	
				V <sub>CE</sub> =2V, I <sub>OUT</sub> =300mA		-	-	3.0	
	IK62084			V <sub>CE</sub> =2V, I <sub>OUT</sub> =125mA		-	-	5.0	
				V <sub>CE</sub> =2V, I <sub>OUT</sub> =200mA		-	-	6.0	
				V <sub>CE</sub> =2V, I <sub>OUT</sub> =275mA		-	-	7.0	
				V <sub>CE</sub> =2V, I <sub>OUT</sub> =350mA		-	-	8.0	
DC Current Transfer Ratio		h <sub>FE</sub>	2	V <sub>CE</sub> =2V, I <sub>OUT</sub> =350mA		1000	-	-	
Clamp Diode Reverse Current		I <sub>R</sub>	6	Ta=25°C (Note)		-	-	50	uA
				Ta=85°C (Note)		-	-	100	
Clamp Diode Forward Voltage		V <sub>F</sub>	7	I <sub>F</sub> =350mA		-	-	2.0	V
Input Capacitance		C <sub>IN</sub>	-			-	-	15	pF
Turn-On Delay		t <sub>ON</sub>	8	R <sub>L</sub> =125Ω, V <sub>OUT</sub> =50V		-	0.1	-	us
Turn-Off Delay		t <sub>OFF</sub>	8	R <sub>L</sub> =125Ω, V <sub>OUT</sub> =50V		-	0.21	-	us

Note : V<sub>R</sub>=V<sub>R</sub>MAX

Test Circuit

1.  $I_{CEX}$

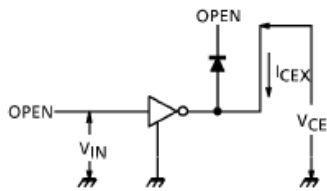

2.  $V_{CE(sat)}$ ,  $h_{FE}$

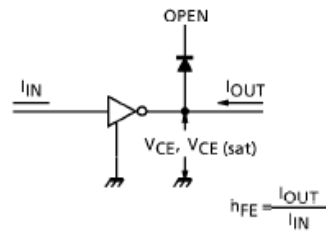

3.  $I_{IN(ON)}$

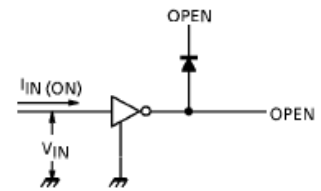

4.  $I_{IN(OFF)}$

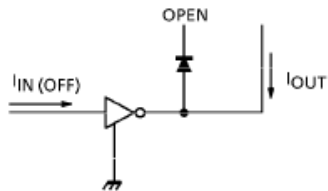

5.  $V_{IN(ON)}$

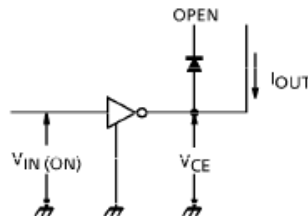

6.  $I_R$

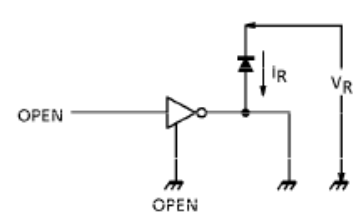

7.  $V_F$

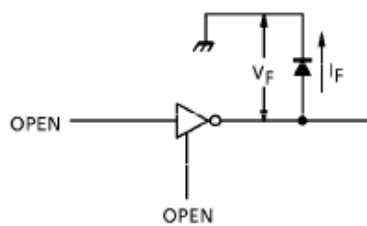

8.  $t_{ON}$ ,  $t_{OFF}$

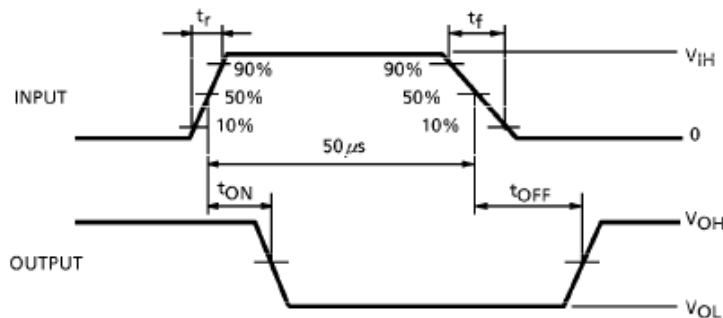
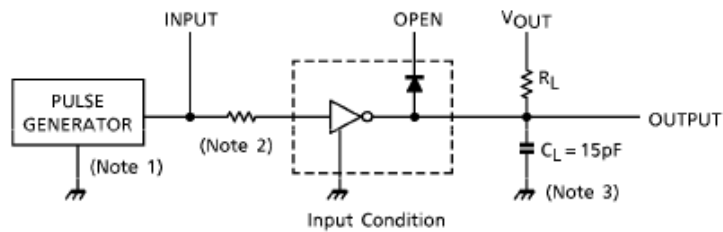

Note 1 : Pulse Width 50us, Duty Cycle 10%  
 Output Impedance 50Ω,  $t_r \leq 5ns$ ,  $t_f \leq 10ns$   
 Note 2 : See below.

**Input Condition**

Type number	R1	$V_{IH}$
IK62083	0Ω	3V
IK62084	0Ω	8V

Note 3 :  $C_L$  includes probe and jig capacitance

**Precautions for Using**

Utmost care is necessary in the design of output line, COMMON and GND line since IC may be destroyed due to short-circuit between outputs, air contaminaton fault, or fault by improper grounding.

IK62083N

IIN vs VIN

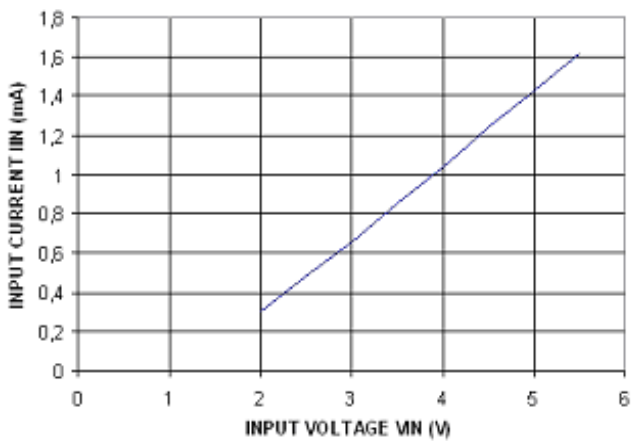

IK62084

IIN vs VIN

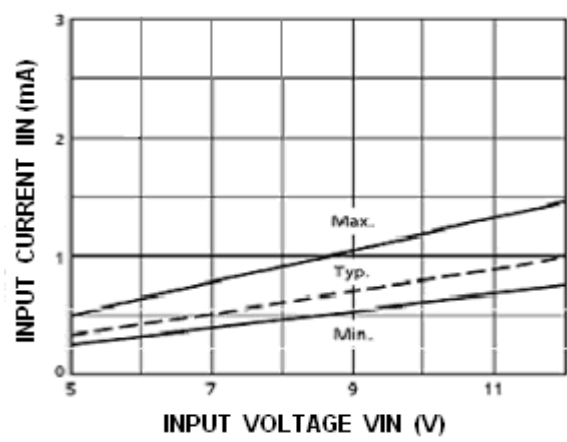

IOUT vs DUTY CYCLE

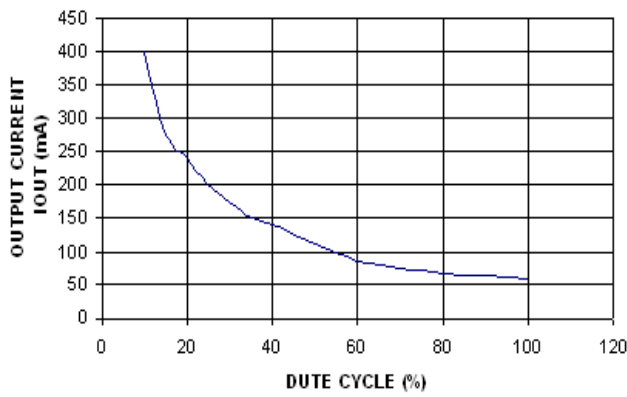

IOUT vs VCE (sat)

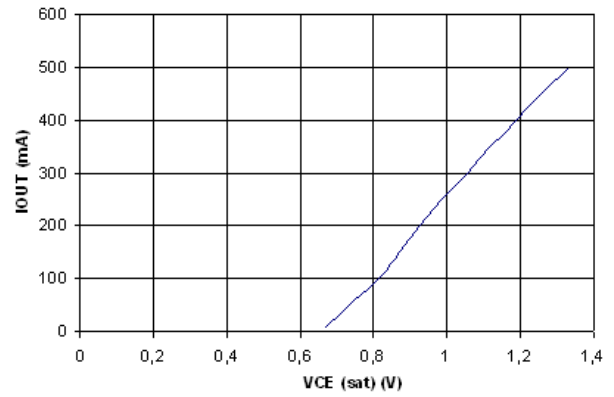

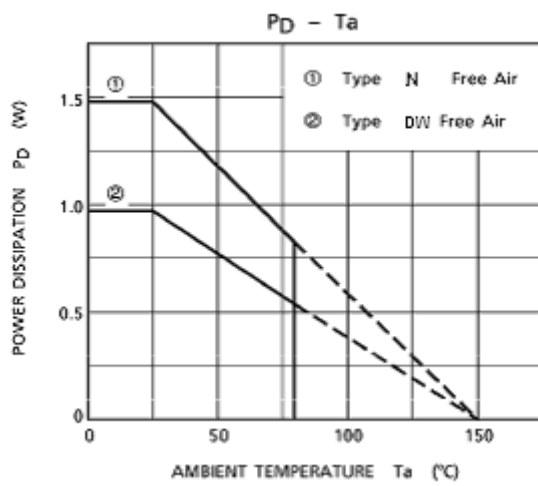
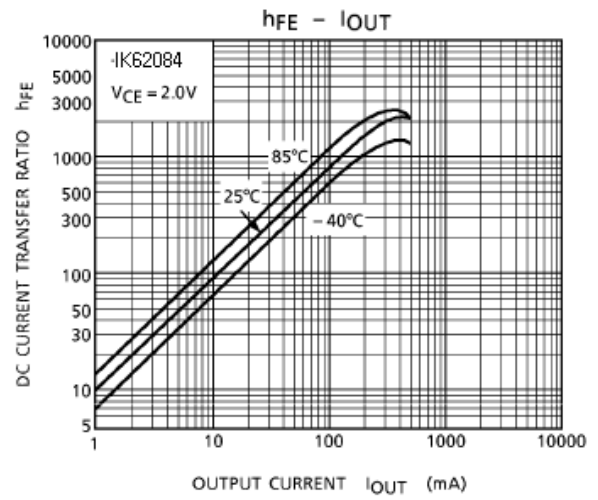
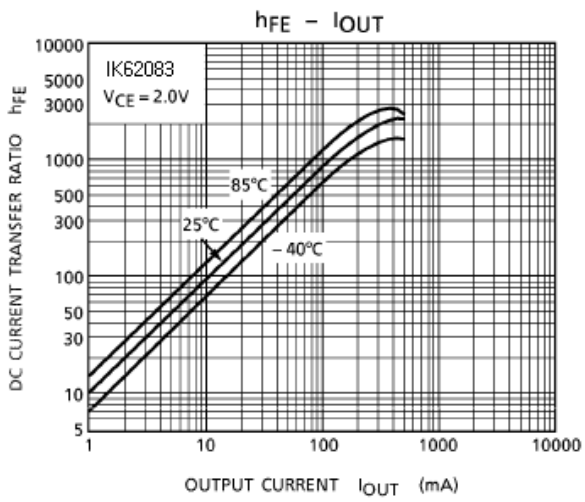

Package Dimensions

DIP-18

Unit: mm

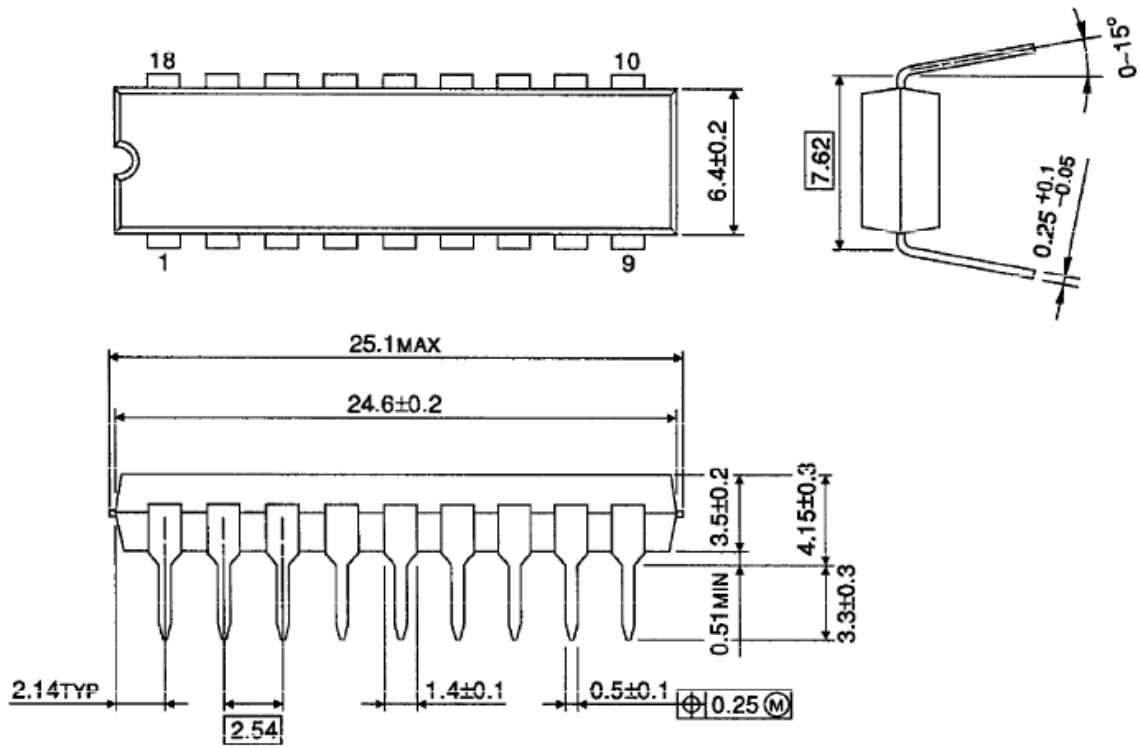



SOP-18

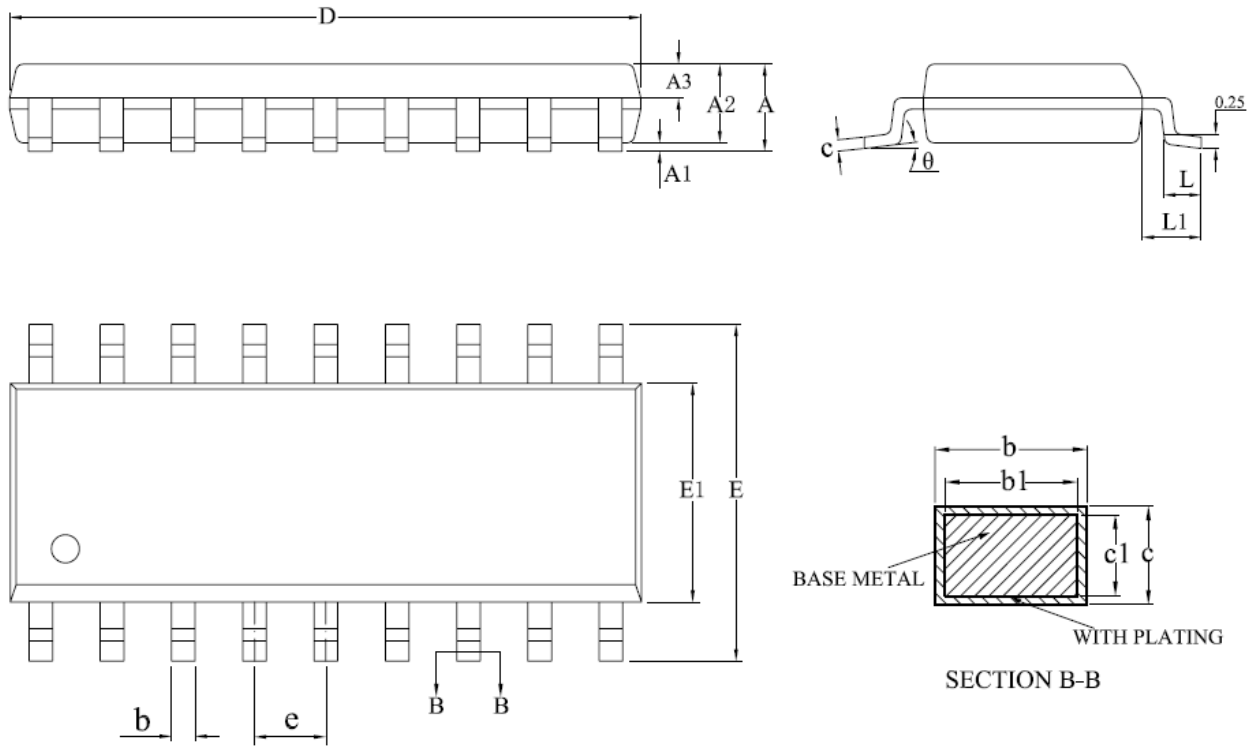

SYMBOL	MILLIMETER		
	MIN	NOM	MAX
A	—	—	2.70
A1	0.10	—	0.28
A2	2.25	2.30	2.35
A3	0.97	1.02	1.07
b	0.35	—	0.44
b1	0.34	0.37	0.39
c	0.26	—	0.31
c1	0.24	0.25	0.26
D	11.25	11.45	11.65
E	10.10	10.30	10.50
E1	7.30	7.50	7.70
e	1.27BSC		
L	0.70	—	1.00
L1	1.40BSC		
θ	0	—	8°
L/P载体尺寸 (mil)	140*160		