

超小形ZIFタイプFPC用コネクタ(リフロー半田用)Lタイプ
ZIF TYPE FPC CONNECTORS (Reflow Soldering Terminals) L Type

UNIT : mm

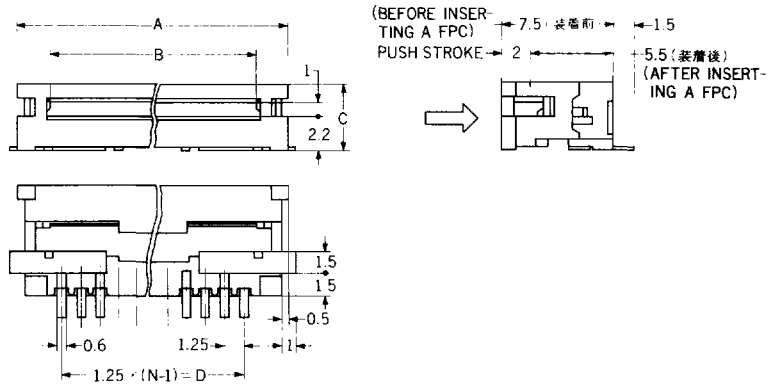

HVC3100 Series



HVC3300 Series

リフロー半田時の位置決め用ガイドポスト付です。作業の向上と半田付強度の向上がはかれます。
 HVC3200 series are provided with a guide post to facilitate accurate positioning during reflow soldering. This improves both work efficiency and soldering strength.

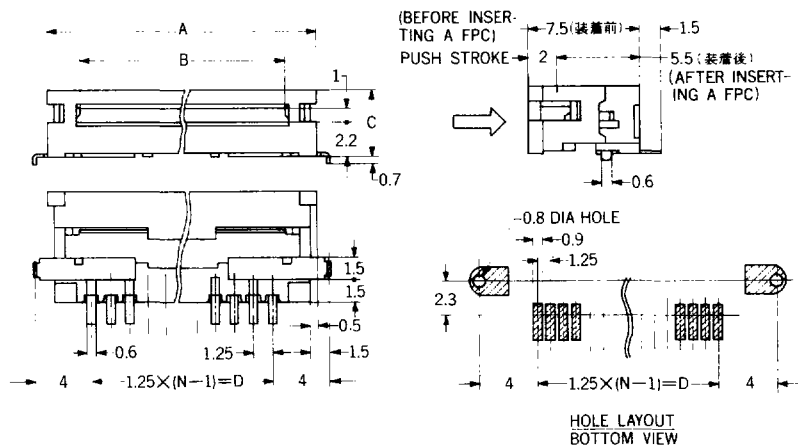

HVC3600 Series

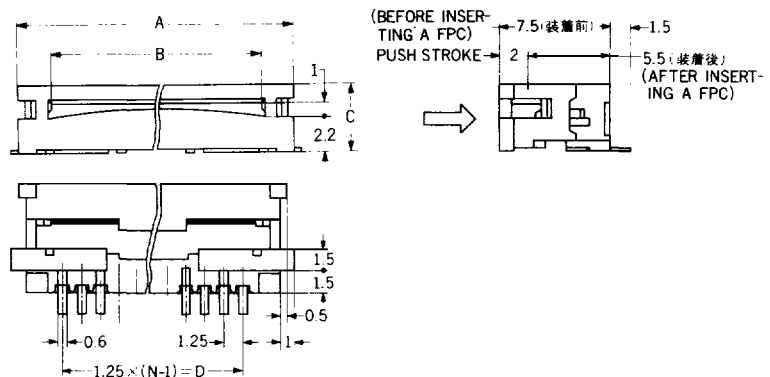

超小形ZIFタイプFPC用コネクタ(リフロー半田用)Lタイプ

ZIF TYPE FPC CONNECTORS (Reflow Soldering Terminals) L Type

UNIT : mm



HVC3800 Series

リフロー半田時の位置決め用ガイドポスト付です。作業の向上と半田付強度の向上がはかれます。

HVC3700 series are provided with a guide post to facilitate accurate positioning during reflow soldering. This improves both work efficiency and soldering strength.

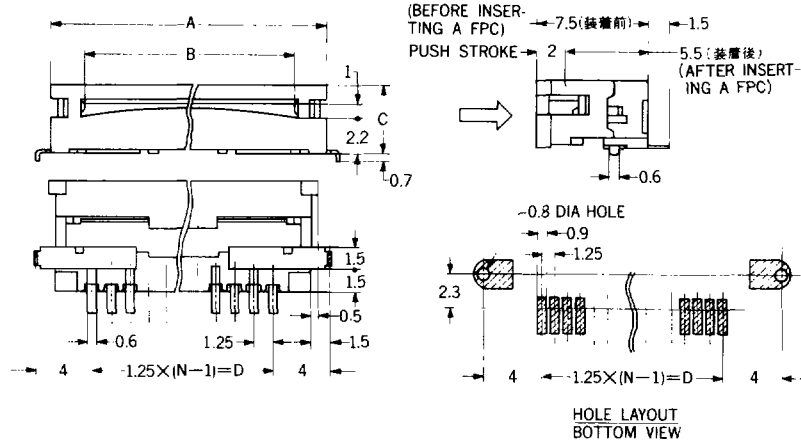

Number of Contact	L Type / Reflow Soldering Terminal				Dimension			
	HVC3100 Series	HVC3300 Series	HVC3600 Series	HVC3800 Series	A	B	C	D
5				HVC3805-01-010	11	6.6	4.5	5
6				HVC3806-01-010	12.25	7.85	4.5	6.25
7			HVC3607-01-010	HVC3807-01-010	13.5	9.1	4.5	7.5
8			HVC3608-01-010	HVC3808-01-010	14.75	10.35	4.5	8.75
9	HVC3109-01-010	HVC3309-01-010			16	11.6	4.5	10
10					17.25	12.85	4.5	11.25
11	HVC3111-01-010	HVC3311-01-010			18.5	14.1	4.6	12.5
12			HVC3612-01-010	HVC3812-01-010	19.75	15.35	4.6	13.75
13					21	16.6	4.6	15
14			HVC3614-01-010	HVC3814-01-010	22.25	17.85	4.6	16.25
15			HVC3615-01-010	HVC3815-01-010	23.5	19.1	4.6	17.5
16					24.75	20.35	4.7	18.75
17	HVC3117-01-010	HVC3317-01-010			26	21.6	4.7	20
18			HVC3618-01-010	HVC3818-01-010	27.25	22.85	4.7	21.25
19					28.5	24.1	4.7	22.5
20			HVC3620-01-010	HVC3820-01-010	29.75	25.35	4.7	23.75
21					31	26.6	4.8	25
22			HVC3622-01-010	HVC3822-01-010	32.25	27.85	4.8	26.25
23					33.5	29.1	4.8	27.5
24					34.75	30.35	4.8	28.75
25					36	31.6	4.8	30
26					37.25	32.85	4.9	31.25
27					38.5	34.1	4.9	32.5
28					39.75	35.35	4.9	33.75
29					41	36.6	4.9	35
30					42.25	37.85	4.9	36.25

注記:

- 上記品番表の製品について
 - 絶縁材料: ナイロン66(ガラス入り)
 - ULフレームクラス: 94V-O
 - 適合FPC仕様: SnPbメッキ
- 上記製品以外に耐熱グレードも可能です。カーボンコートおよび金メッキのFPC仕様にも対応できます。別途ご相談ください。

NOTES:

- Products with the model numbers listed above
 - Insulating Material : NYLON 66 (Glass-reinforced)
 - UL Flame-Resistance Class : 94V-O
 - Applicable FPC Specifications : SnPb Plating
- In addition to the products above, heat resistant grades are also available. Connectors for carbon-coated and gold-plated FPCs can be produced. Consult us for details.