

FEATURES

- Complete PWM Power Control Circuitry
- Uncommitted Outputs for 200 mA Sink or Source Current
- Output Control Selects Single-Ended or Push-Pull Operation
- Internal Circuitry Prohibits Double Pulse at Either Output
- Variable Dead-Time Provides Control over Total Range
- Internal Regulator Provides a Stable 5-V Reference Supply, 5%
- Circuit Architecture Allows Easy Synchronization
- Moisture Sensitivity Level 3

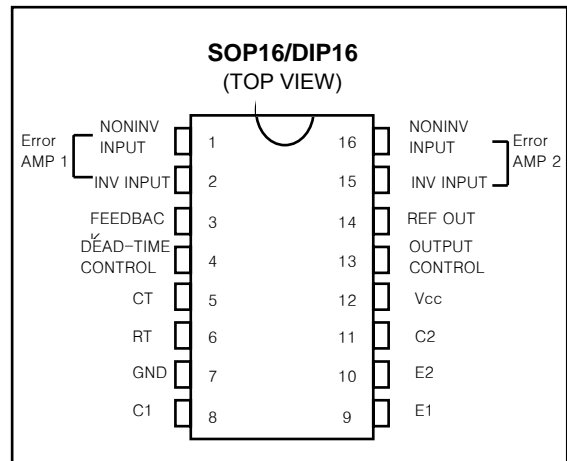

DESCRIPTION

The TL494 incorporate on a single monolithic chip all the functions required in the construction of a pulse-width-modulation control, these devices offer the systems engineer the flexibility to tailor the power supply control circuitry to his application.

The TL494 contains an error amplifier, an on-chip adjustable oscillator, a dead-time control comparator, pulse-steering control flip-flop, a 5-volt, 5% precision regulator, and output-control circuit.

The error amplifier exhibits a common-mode voltage range from -0.3 volts to $V_{cc} - 2$ volts. The dead-time control comparator has a fixed offset that provides approximately 5% dead time when externally altered. The on-chip oscillator may be bypassed by terminating R_T (pin 6) to the reference output and providing a sawtooth in put to C_T (pin 5), or it may be used to drive the common circuits in synchronous multiple-rail power supplies. The uncommitted output transistors provide either common-emitter or emitter-follower output capability. Each Device provides for push-pull or single-ended output operation, which may be selected through the output-control function. The architecture of these devices prohibits the possibility of either output being pulsed twice during push-pull operation.

ORDERING INFORMATION

Device	Package
TL494D	16 SOP
TL494N	16 DIP

Functional Block Diagram

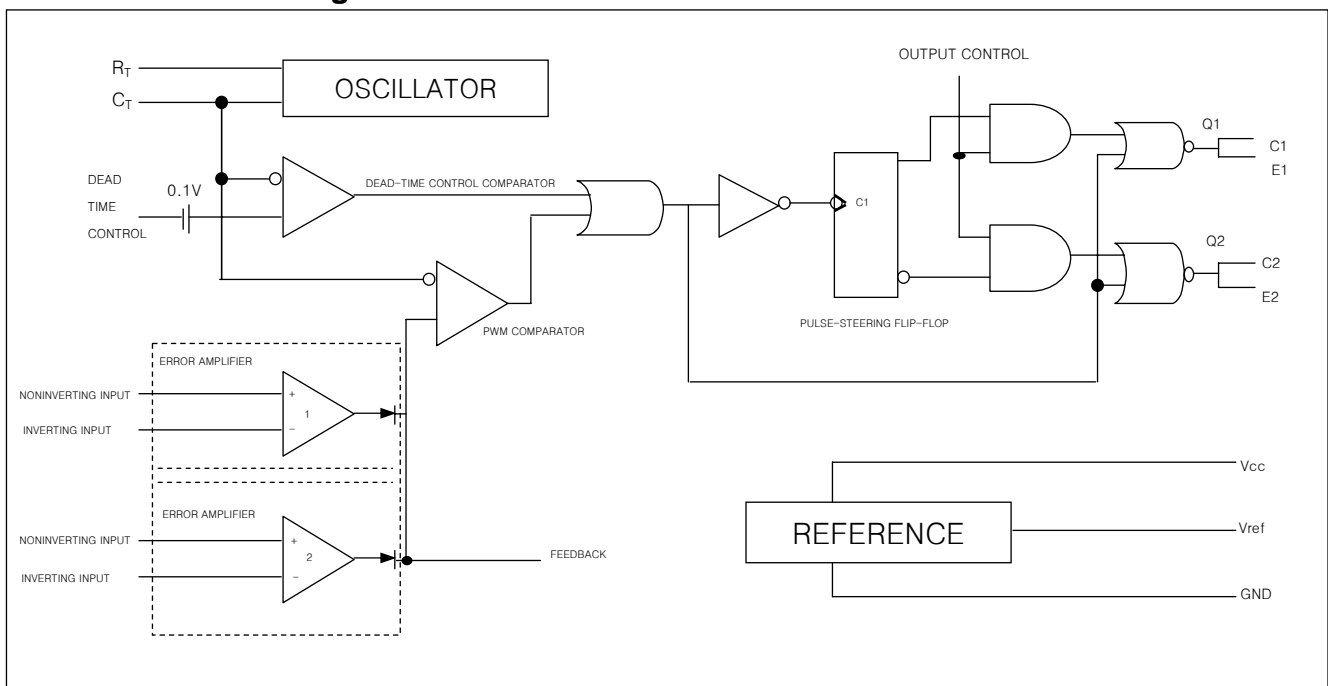

Parameter measurement information

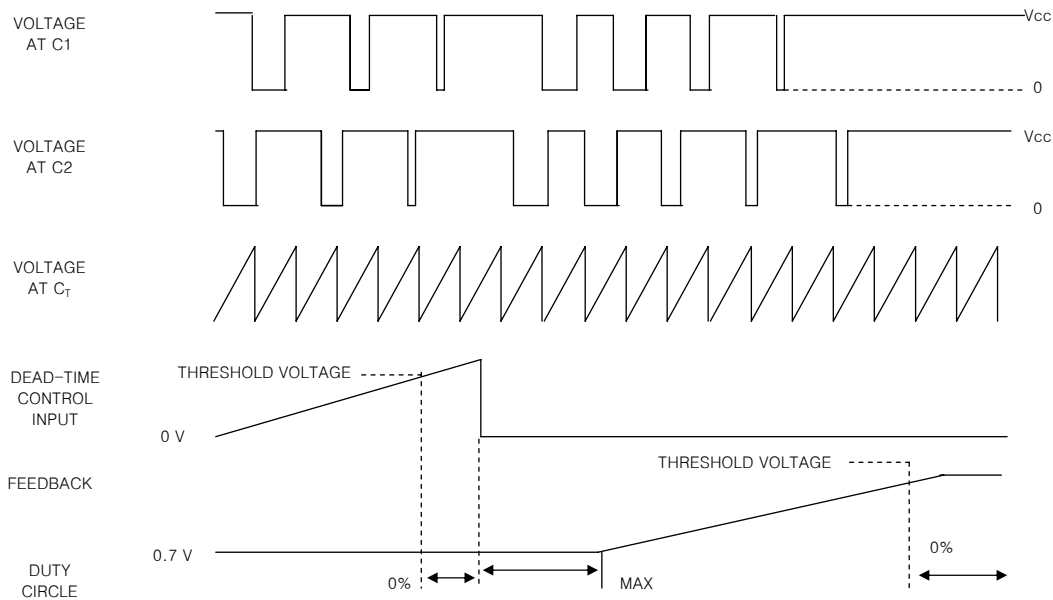
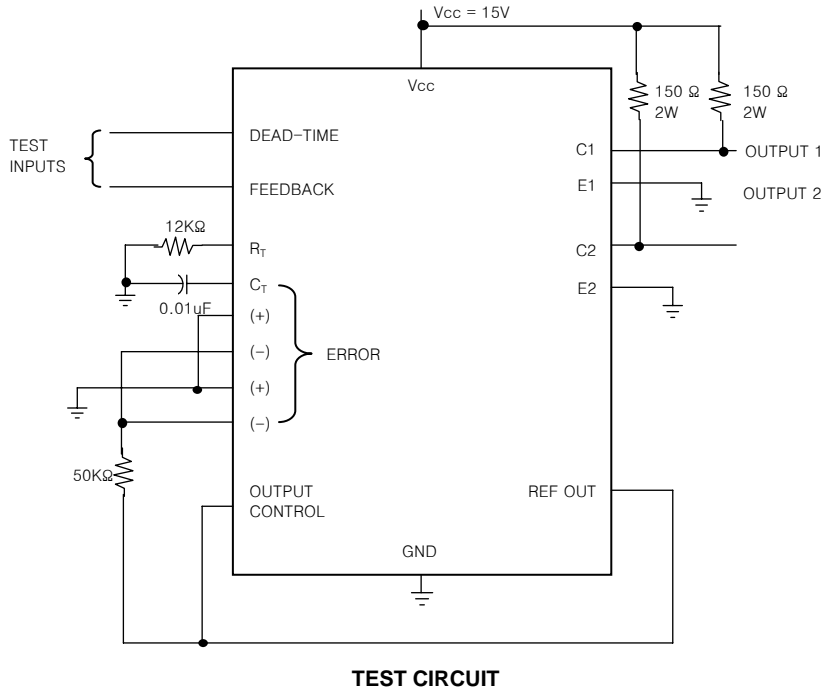

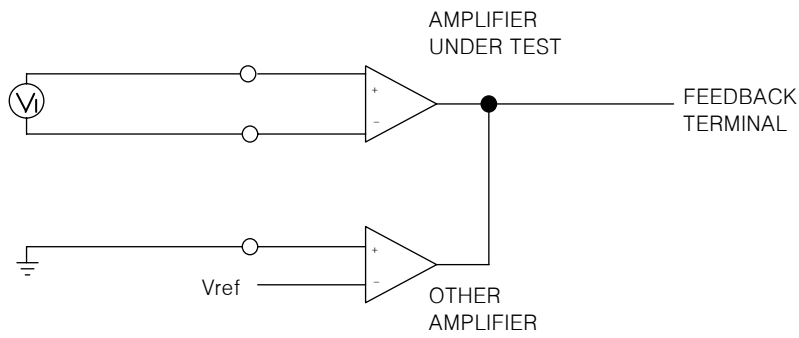

FIGURE 2. AMPLIFIER CHARACTERISTICS

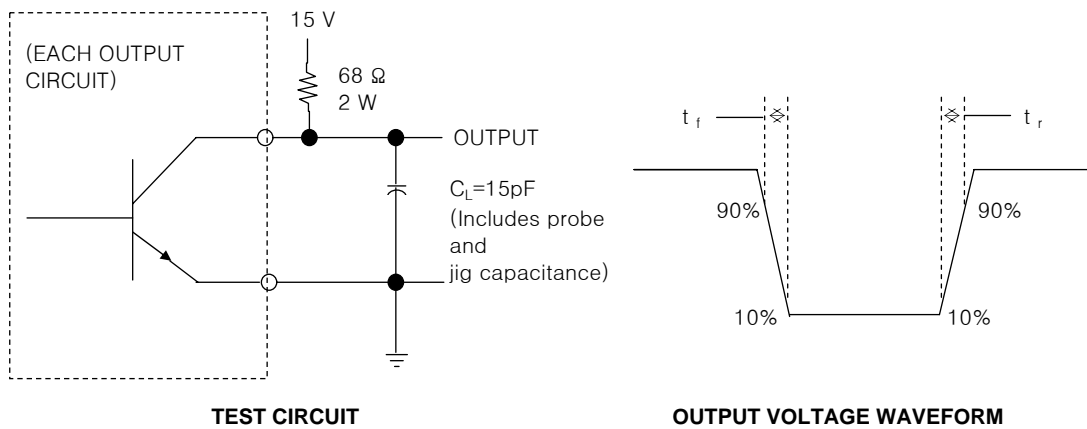

FIGURE 3. COMMON-EMITTER CONFIGURATION

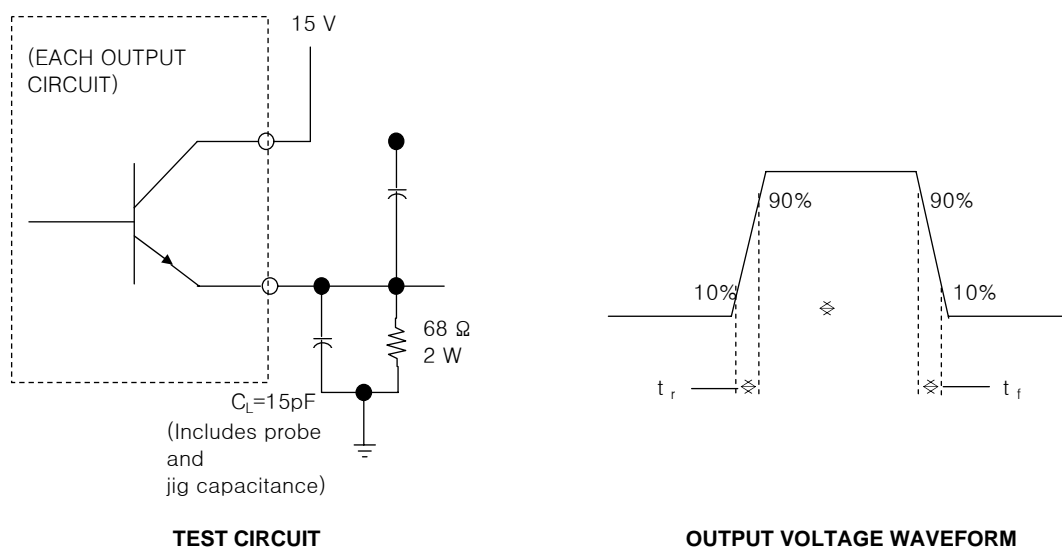

FIGURE 4. EMITTER-FOLLOWER CONFIGURATION

ABSOLUTE MAXIMUM RATINGS OVER OPERATING FREE-AIR TEMPERATURE RANGE

Rating	Value	Unit
Supply voltage, V _{cc}	41	V
Amplifier input voltage	V _{cc} +0.3	
Collector output voltage	41	
Collector output current	250	mA
Operating free-air temperature range	-40 to 125	°C
Storage temperature range	-65 to 150	
Lead temperature 1,6 mm from case for 10 seconds	260	

RECOMMENDED OPERATING CONDITIONS

Parameter	Value		Unit
	MIN	MAX	
Supply voltage, V _{cc}	7	40	V
Amplifier input voltage, V _i	-0.3	V _{cc} -2	
Collector output voltage, V _o		40	
Collector output current (each transistor)		200	mA
Current into feedback terminal		0.3	
Timing capacitor, C _T	0.47	10000	nF
Timing resistor, R _T	1.8	500	KΩ
Oscillator frequency	1	300	KHz
Operating free-air temperature, T _A	-40	85	°C

Electrical characteristics over recommended operating free-air temperature range,**V_{cc}=15V, f= 10 kHz(unless otherwise noted).**

Parameter	Test Conditions*	Value			Unit
		MIN	TYP**	MAX	
Output voltage (V _{ref})	I _o = 1mA	4.75	5	5.25	V
Input regulation	V _{cc} = 7V to 40 V		2	25	mV
Output regulation	I _o = 1mA to 10mA		1	15	
Output voltage change with temperature	T _A = MIN to MAX		0.2	1	%
Short-circuit output current***	V _{ref} = 0		35		mA

Oscillator section (See Figure 1)

Parameter	Test Conditions*	Value			Unit
		MIN	TYP**	MAX	
Frequency	C _T =0.01μF, R _T =12KΩ		10		KHz
Standard deviation of frequency****	All values of V _{cc} , C _T , R _T , and T _A constant		10		%
Frequency change with voltage	V _{cc} =7V to 40V, T _A =25oC		0.1		
Frequency change with temperature****	C _T =0.01μF, R _T =12KΩ, T _A = MIN to MAX			1	

Electrical characteristics over recommended operating free-air temperature range,
 $V_{CC}=15V$, $f=10kHz$ (unless otherwise noted)

Amplifier section (See Figure 2)

SYMBOL	TEST CONDITIONS	MIN.	TYP**.	MAX.	UNIT
Input offset voltage	$V_o(\text{pin } 3)=2.5V$		2	10	mV
Input offset current	$V_o(\text{pin } 3)=2.5V$		25	250	nA
Input bias current	$V_o(\text{pin } 3)=2.5V$		0.2	1	μA
Common-mode input voltage range	$V_{CC} = 7V \text{ to } 40V$	-0.3~-2			V
Open-loop voltage amplification	$V_o=3V$, $R_L=2K\Omega$, $V_o=0.5\sim 3.5V$	70	95		dB
Unity-gain bandwidth	$V_o=0.5\sim 3.5V$, $R_L=2K\Omega$		800		kHz
Common-mode rejection ratio	$V_o= 40V$, $T_A= 25^\circ C$	65	80		dB
Output sink current (pin 3)	$V_{ID}=-15mV\sim -5V$, $V_{(\text{pin}3)}=0.7V$	0.3	0.7		mA
Output source current (pin 3)	$V_{ID}=15mV\sim 5V$, $V_{(\text{pin}3)}=3.5V$	-2			mA

*For conditions shown as MIN or MAX, use the appropriate value specified under recommended operating conditions.

** All typical values except for parameter changes with temperature are at $T_A = 25^\circ C$

*** Duration of the short-circuit should not exceed one second.

**** Standard deviation is a measure of the statistical distribution about the mean as derived from the formula.

***** Temperature coefficient of timing capacitor and timing resistor not taken into account.

Output section

PARAMETER	TEST CONDITIONS	MIN.	TYP*	MAX.	UNIT
Collector off-state current	$V_{CE}=40V$, $V_{CC}=40V$		2	100	μA
Emitter off-state current	$V_{CC}=V_C=40V$, $V_E=0$			-100	
Collector-emitter saturation voltage	Common-emitter		1.1	1.3	V
	Emitter-follower		1.5	2.5	
Output control input current	$V_I=V_{ref}$			3.5	mA

Dead-time control-section (See Figure 1)

PARAMETER	TEST CONDITIONS	MIN.	TYP*	MAX.	UNIT
Input bias current(pin4)	$V_I=0 \text{ to } 5.25V$		-2	-10	μA
Maximum duty cycle, each output	$V_{I(\text{pin } 4)}=0$, $C_T=0.1\mu F$, $R_T=12K\Omega$		45		%
Input threshold voltage(pin 4)	Zero duty cycle		3	3.3	V
	Maximum duty cycle	0			

PMW comparator section (See Figure 1)

PARAMETER	TEST CONDITIONS	MIN.	TYP*	MAX.	UNIT
Input threshold voltage (pin3)	Zero duty cycle		4	4.5	V
Input sink current (pin 3)	$V(\text{pin}3) = 0.7V$	0.3	0.7		mA

Total device

PARAMETER	TEST CONDITIONS	MIN.	TYP*	MAX.	UNIT	
Standby supply current	Pin 6 at V_{ref} , all other inputs and outputs open	$V_{CC}=15V$		6	10	mA
		$V_{CC}=40V$		9	15	
Average supply current	$V_I(\text{pin } 4)= 2V$		7.5			

Switching characteristics, $T_A = 25^\circ\text{C}$

PARAMETER	TEST CONDITIONS	MIN.	TYP*	MAX.	UNIT
Output voltage rise time	Common-emitter configuration		100	200	ns
Output voltage fall time			25	100	
Output voltage rise time	Emitter-follower configuration		100	200	
Output voltage fall time			40	100	

* All typical values except for temperature coefficient are at $T_A = 25^\circ\text{C}$

