

# SPECIFICATION

## 868MHz ISM Band Dipole Antenna

- Part No. : **OMB.868.B05F21**
- Product Name : 5dBi 868MHz ISM Band Indoor/Outdoor  
Omni-Directional Antenna
- Feature : Suitable to use in robust outdoor environment  
Dimensions: Height 1093.5mm  
**RoHS compliant**



## 1. Introduction

The 868MHz Barracuda ISM Outdoor antenna is designed to have a long distance coverage. Omni-directional high gain across all bands ensures constant reception and transmission. The UV resistant coating with fiberglass housing makes this antenna suitable to be mounted in robust outdoor environment, pole-mounting and wall-mounting bracket is included.

The antenna finds its usage in metering, industrial monitoring and security applications.

## 2. Specification

ELECTRICAL	
Standard	ISM 868
Band	860~870MHz
Antenna Type	Collinear
Gain(max)	5dBi
Polarization	Vertical
Impedance	50 ohms
Max Input Power	50 watts
VSWR	<1.5:1
Radiation	Omni-Directional
Vertical Beam-width	38 Deg
Horizontal Beam-width	360 Deg
Antenna Design	Dipole Array
Internal Material	Copper
Connector	N Type Female
MECHANICAL	
Length	1094mm(Max)
Base Diameter	70*55mm(Max)
Antenna Weight(G.W)	680g
Mounting Accessories(G.W)	70g
Application	Indoor/Outdoor
Radome Material	White Fiberglass
Base Material	Aluminum
Mount Style	Pole Mount/Wall Mount
Mounting	Stainless Steel
Wind Resistance	>150mph(>241km/h)
Housing	Fiberglass
ENVIRONMENTAL	
Storage Temperature	-20°C to +80°C
Operating Temperature	-20°C to +60°C
Operating Humidity	10%~80% non-condensing
Storage Humidity	5%~80% non-condensing

### 3. Antenna Characteristics

#### 3.1 Return Loss

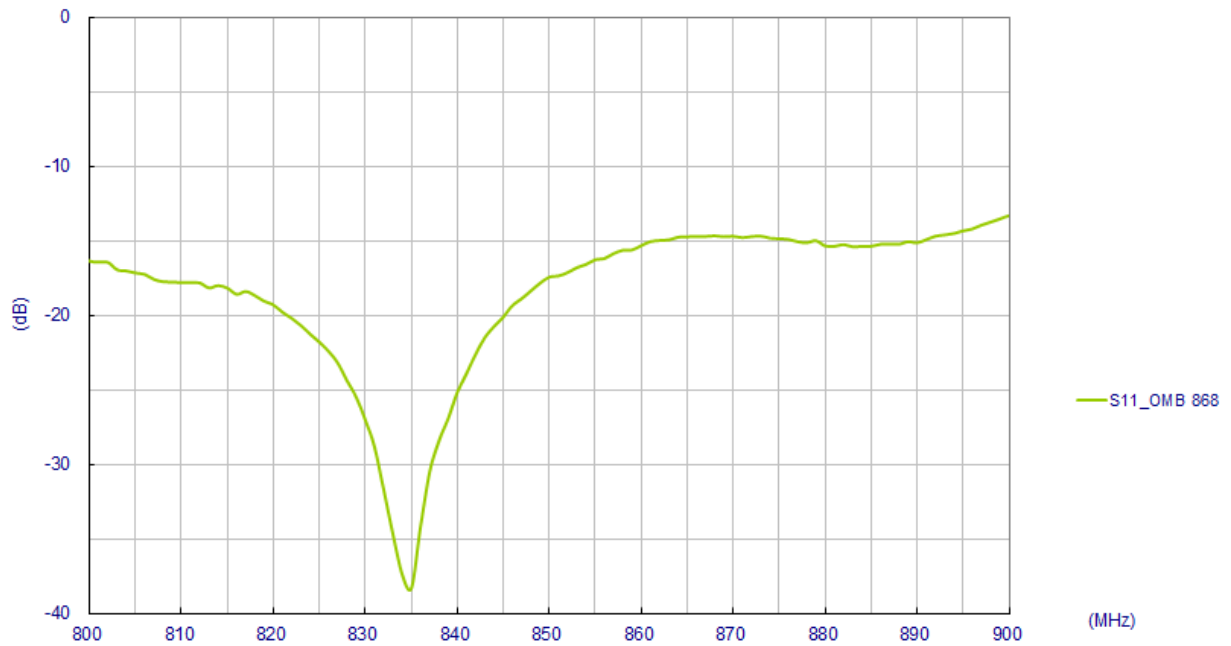

#### 3.2 Maximum Gain

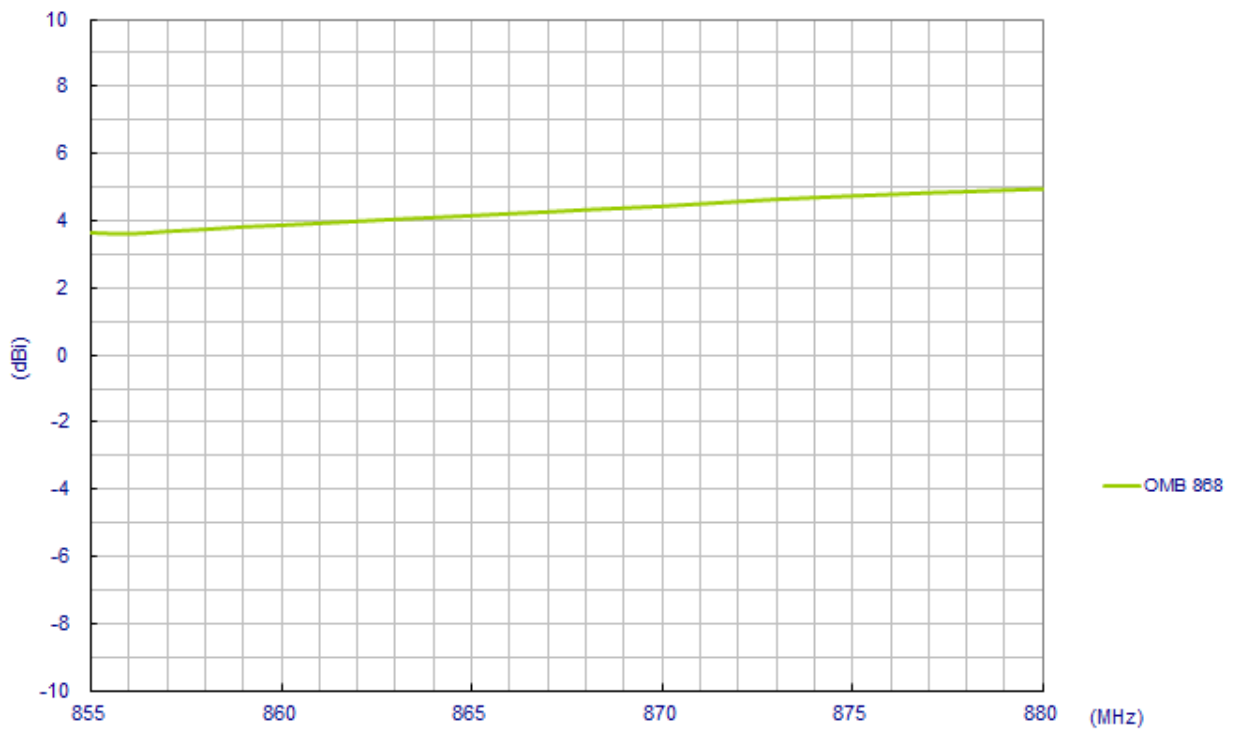

### 3.3 Average Gain

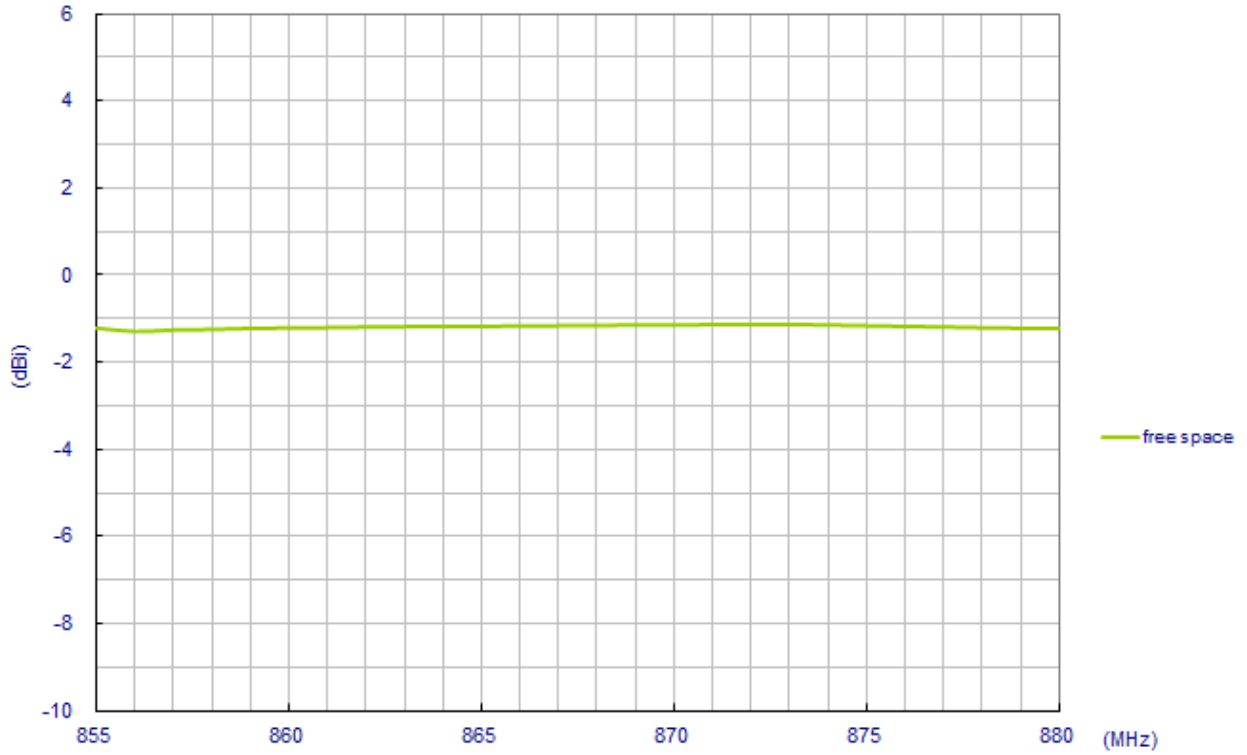

### 3.4 Efficiency

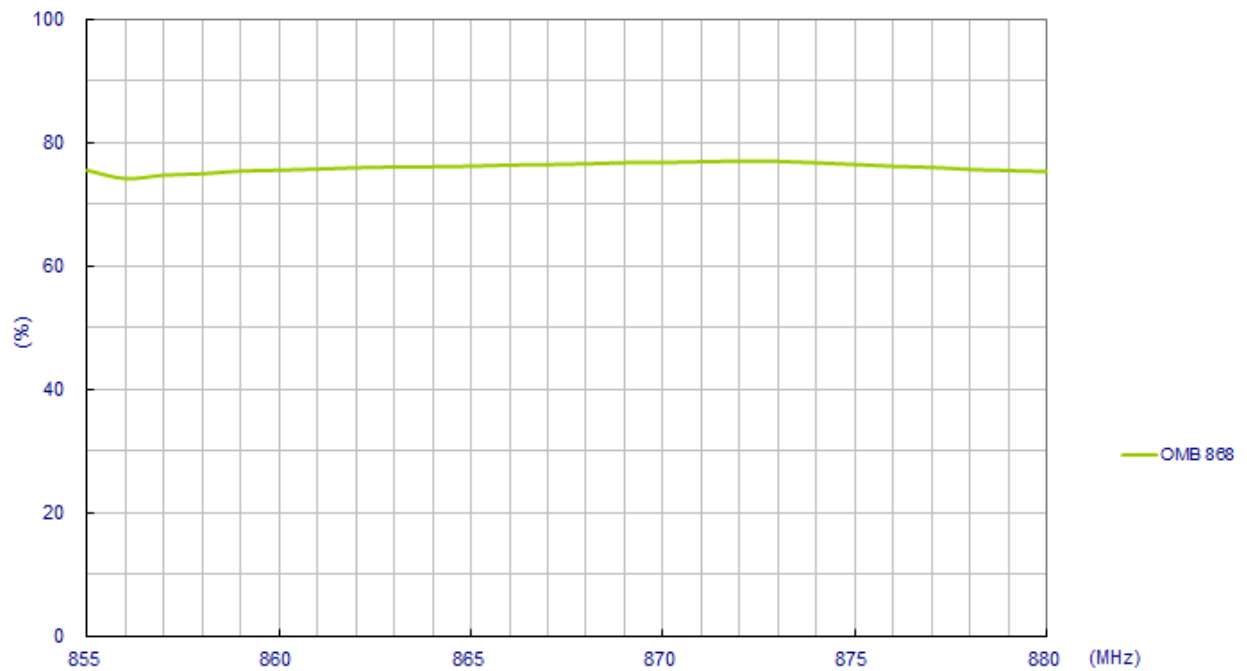

## 4.3D Radiation Property

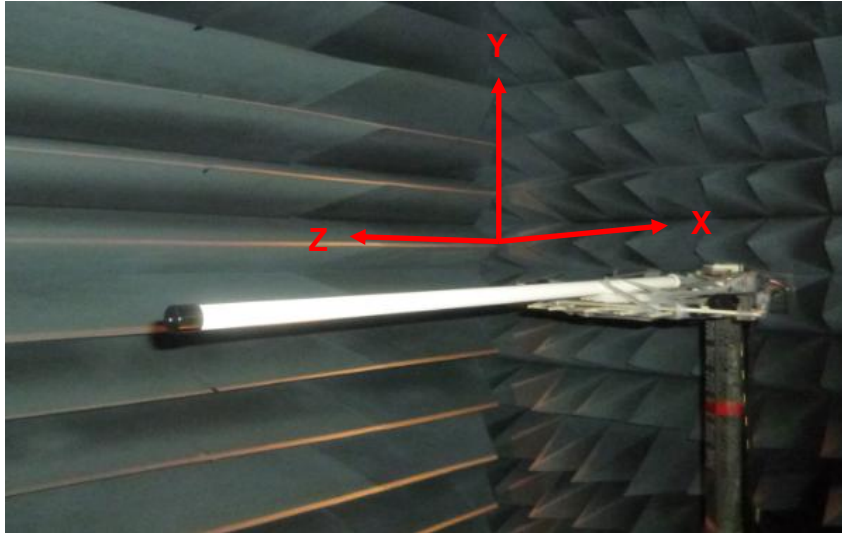

XY plane

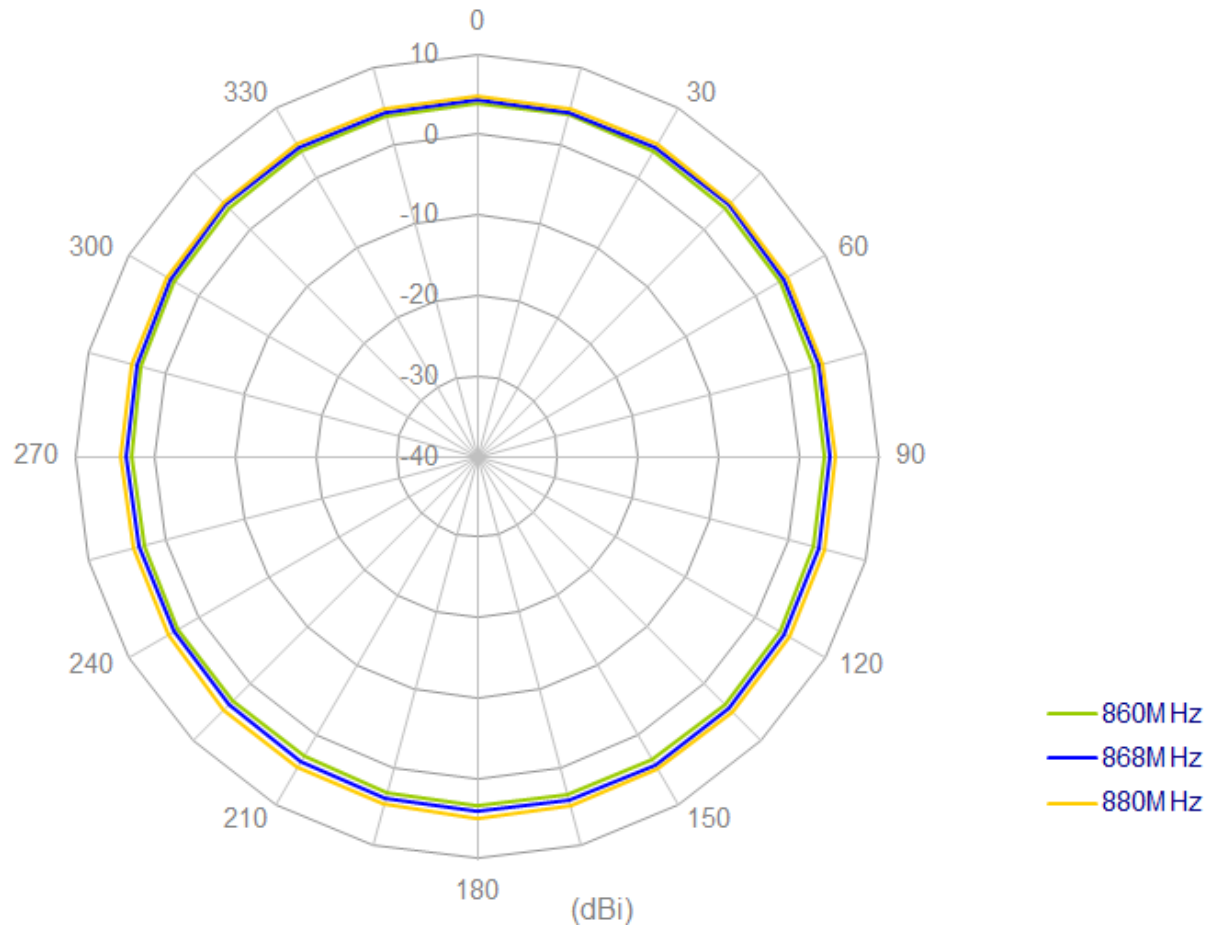

XZ plane

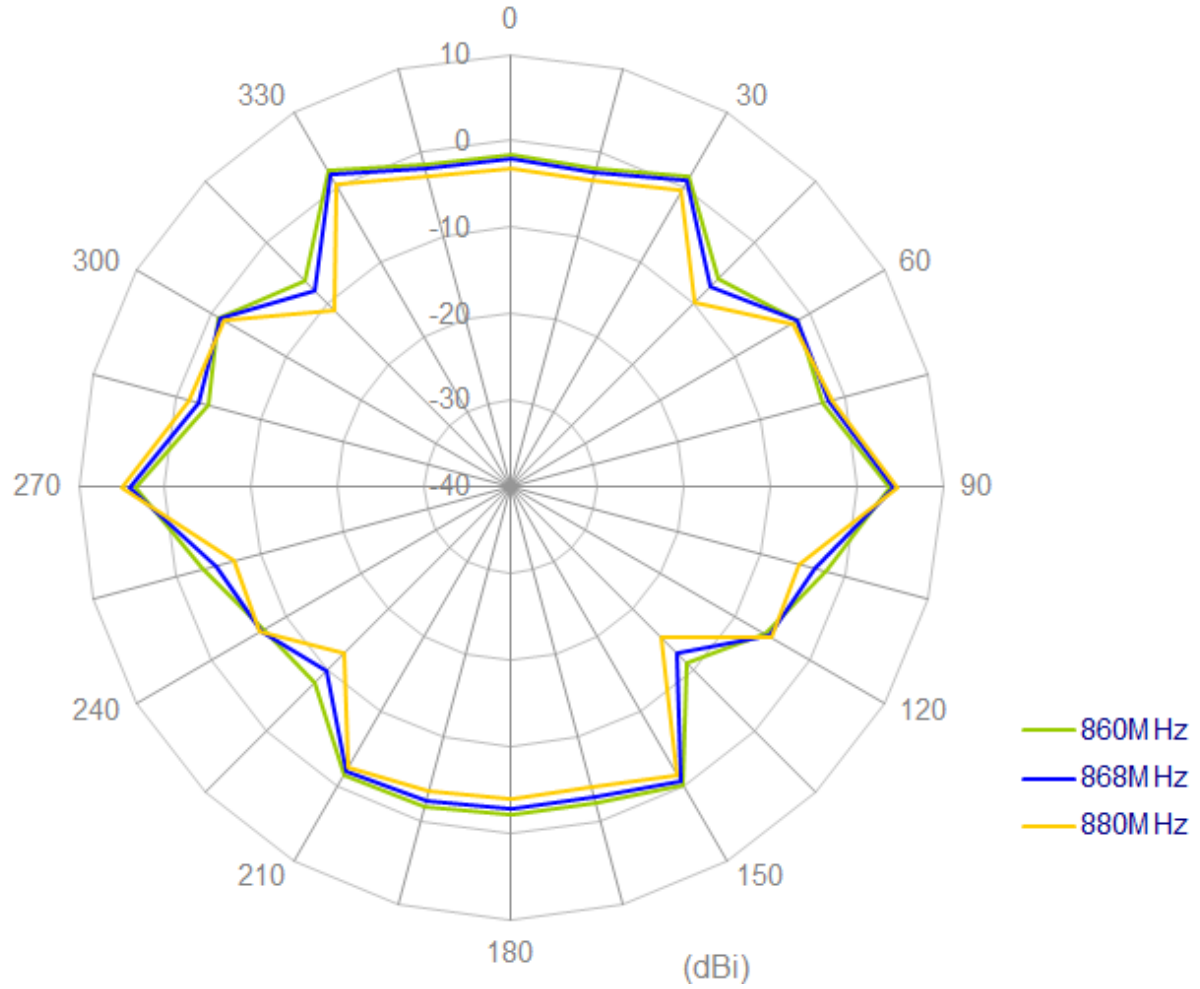



# 5. Drawing

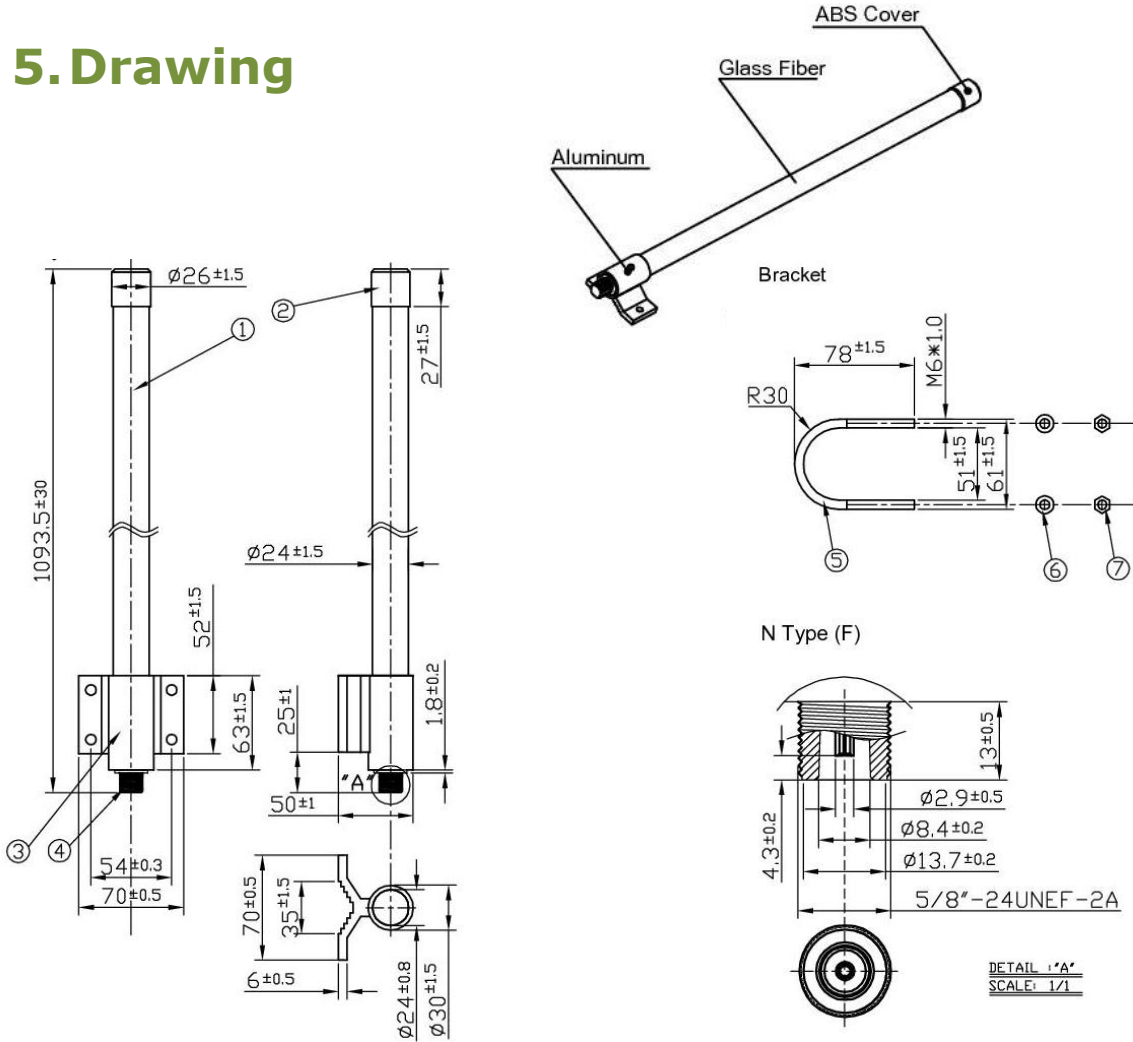

	Name	P/N	Material	Finish	QTY
1	OMB.868 Antenna	001212B010021A	Glass Fiber	White	1
2	Cover	000111K000021A	ABS	Silver	1
3	Holder	000311K000021A	Aluminum	Silver	1
4	N Type(F)	201211K000021A	Brass	Ni Plated	1
5	M6 U Type Screw	000411K000021A	Stainless Steel	Silver	2
6	M6 Washer	000411K010021A	Stainless Steel	Silver	4
7	M6 Nut	000411K020021A	Stainless Steel	Silver	4