



SPECIFICATION

GENERAL SUMMARY FOR SWITCH SERIES 8500

From this range of subminiature rocker switches, a choice can be made to the type of operation that is required with a selection of SP and DP action, with or without illumination.

STYLING

Appearance was in the forefront of the designers mind of this attractive range of switches with its soft appearance and fine textured finish.

QUALITY

Modern methods of manufacture and constant quality control checks enable us to produce switches to conform with worldwide approvals.

MATERIALS

Careful selection of materials enable us to meet the technical requirements of the various approval authorities and customer requirements. Generally, grades of Nylon or Polycarbonate are used for the Body and Actuator. The use of Brass or Copper with integral silver contacts where necessary to ensure we meet the Electrical and mechanical functions, ensuring good performance.

VARIANTS

With our modern and flexible methods of production we can, as well as supplying switches in different colours and printed decor, also offer the choice of different electrical terminations.

ENDURANCE

Switches are designed and manufactured to conform to both the electrical and mechanical requirements of the worldwide approval authorities. If other requirements have to be met then our technical personnel can test to meet your requirements.



SWITCH TYPES: 8500 Single Pole, 8550 Double Pole with ON/OFF action. 8503 single pole illuminated and 8553 double pole illuminated with ON/OFF action.

ELECTRICAL CHARACTERISTICS

- | | | |
|-----|--|-------------------|
| 1. | Voltage | 250V |
| 2. | Resistive load | 6 amps |
| 3. | Inductive load | 1 amp |
| 4. | Dielectric strengths: | |
| 4.1 | Line parts to access metal | 4000 volts |
| 4.2 | Between open contacts on new switches | 2000 volts |
| 4.3 | Between open contacts on used switches | 1500 volts |
| 5. | Contact gap | < 3.0mm |
| 6. | Switch contact resistance | < 10 milli ohms |
| 7. | Insulating resistance | < 100 Megohms |
| 8. | Tracking Index | 250 volts |
| 9. | Electrical endurance | 10,000 operations |

MECHANICAL CHARACTERISTICS

- | | | |
|----|----------------------|-------------------|
| 1. | Operational force | 1000 grams |
| 2. | Contact pressure | 150 grams |
| 3. | Mechanical endurance | 10,000 operations |

MATERIALS

- | | | |
|----|-------------------|---|
| 1. | Body material | Nylon 66 |
| 2. | Actuator moulding | Nylon 66 or polycarbonate* |
| 3. | Central Terminal | Copper, silver plated |
| 4. | End Terminal | Brass with silver contact and silver plated |
| 5. | Moving contact | Beryllium copper with silver contact. |

* Polycarbonate for illuminated actuators.



8550 continued

ENVIRONMENTAL CHARACTERISTICS

Ambient temperature	85 C maximum with present approval.
Appliance Class	I or II
Flamability Rating	According to UL94V2
Cadium content	None

DIMENSIONS AND PANEL DETAILS

Refer to enclosed drawing	8500 series
---------------------------	-------------

APPROVAL STATUS

See Status Listing
Attached

September, 1986

CHANGE NOTE No.	DATE	ISSUE	CHANGE NOTE No.	DATE	ISSUE	CHANGE NOTE No.	DATE	ISSUE	DRAWN	DLH	CATALOGUE N°
	10/10/84	1			4			7	CHECKED	D.R.	.8550..
	22/7/87	2			5			8	SCALE	!!!	
		3			6			9	DATE	20-9-84	

3RD ANGLE PROJECTION

DO NOT SCALE . IF IN DOUBT- ASK

ORDERING CODE
 PREFIX = TERMINAL TYPE
 1st SUFFIX = ROCKER SHAPE
 2nd SUFFIX = BODY SHAPE

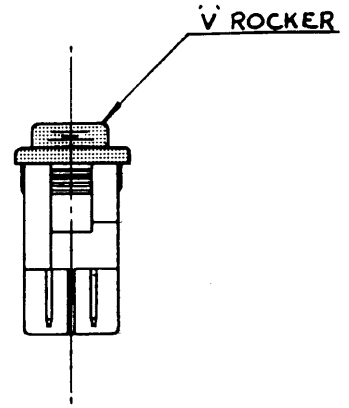
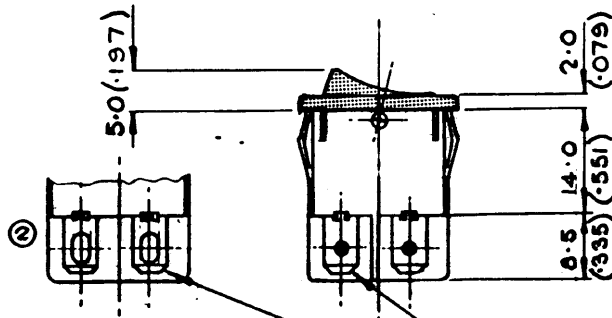
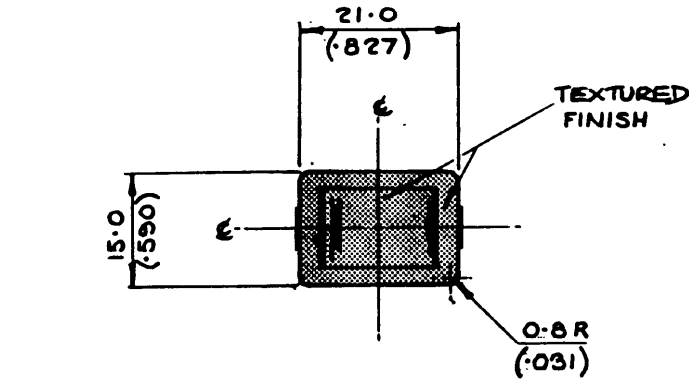

TERMINALS
 TYPE 'H' - 4.8 (.187) TAB
 TYPE 'T' - 4.8 (.187) SOLDER TAG

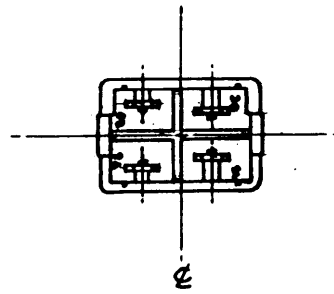

ISSUE 2
 TYPE 'T' TERM-
 ADDED PICTORI-
 ALLY. DM.

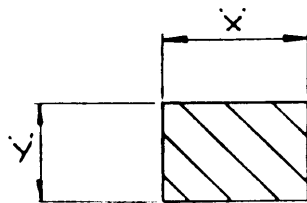

PANEL CUT-OUT DETAILS
 (B BODY SHAPE)

PANEL THICKNESS	DIM. X	DIM. Y
0.75-1.25 (.029-.049)	19.2/19.1 (.756/.752)	13.0/12.9 (.512/.508)
1.25-2.0 (.049-.079)	19.4/19.3 (.764/.760)	13.0/12.9 (.512/.508)
2.0-3.0 (.079-.118)	19.8/19.7 (.779/.775)	13.0/12.9 (.512/.508)



DIMENSIONS IN MILLIMETRES (INCHES)

LIMITS UNLESS OTHERWISE STATED	MAT.	TITLE	USED IN
DECIMALS ± 0.125 (.005)	SPEC.	OUT-LINE DRC OF D/POLE SUB-MIN. ROCKER SWITCH ON/OFF.	CATALOGUE N°
FRACTIONS ± 0.4 (1/64)	FINISH	ARCOLECTRIC SWITCHES LTD. WEST MOLESEY, SURREY.	.8550..

CHANGE NOTE No.	DATE	ISSUE	CHANGE NOTE No.	DATE	ISSUE	CHANGE NOTE No.	DATE	ISSUE	DRAWN	MR	DRAWING No.
		1			4			7	CHECKED		CH 82
		2			5			8	SCALE	F.S.	
		3			6			9	DATE	15/12/86	

3RD ANGLE PROJECTION

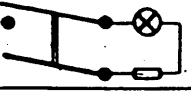
DO NOT SCALE . IF IN DOUBT-ASK

TYPE ACTION	CAT. N ^o .	DESCRIPTION	TERMINAL POSITIONS .
	8500.	SINGLE POLE , ON/OFF	2A 1A
	8503.	SINGLE POLE , ON/OFF. (ILLUMINATED)	2A 1A 3B
	8550.	DOUBLE POLE , ON/OFF .	2A 1A 4B 3B
	8553.	DOUBLE POLE , ON/OFF. (ILLUMINATED)	2A 1A 4B 3B

TEXTURED FINISH .

TERMINAL ARRANGEMENTS FOR SWITCH VARIATIONS. (SEE CHART)

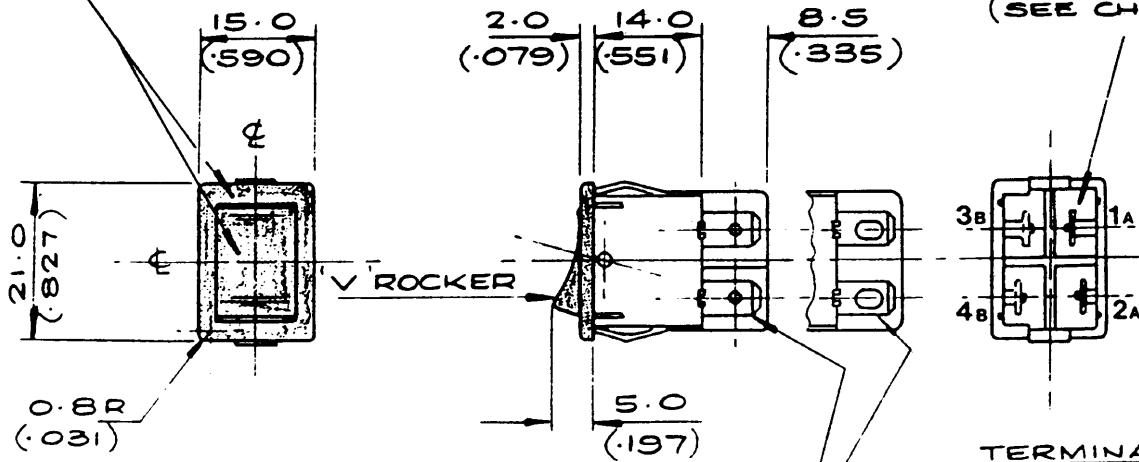

TERMINALS .
TYPE 'H' - 4.8 (.187) TAB .
TYPE 'T' - 4.8 (.187) SOLDER TAG .

PANEL CUT-OUT DETAILS.
B BODY SHAPE

PANEL THICKNESS	DIM ⁿ . X	DIM ⁿ . Y
0.75-1.25 (.029/.049)	19.2/19.1 (.756/.752)	13.0/12.9 (.512/.508)
1.25-2.0 (.049/.079)	19.4/19.3 (.764/.760)	13.0/12.9 (.512/.508)
2.0-3.0 (.079/.118)	19.8/19.7 (.779/.775)	13.0/12.9 (.512/.508)

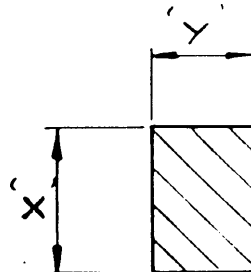

NOTE !
RATING FOR THESE SWITCHES IS 6(1)A (FOR EUROPEAN APPROVALS) AND 6A ONLY (FOR AMERICAN & CANADIAN APPROVALS.)

DIMENSIONS IN MILLIMETRES (INCHES)

LIMITS UNLESS OTHERWISE STATED	MAT.	TITLE	USED IN
DECIMALS ± 0.125 (005)	SPEC.	EXPLANATORY CHART OF THE 8500/8550 SERIES SUB-MINIATURE SWITCHES .	DRAWING No.
FRACTIONS ± 0.4 (1/64)	FINISH	ARCOLECTRIC SWITCHES LTD. WEST MOLESEY, SURREY.	CH 82

ARCOLECTRIC SWITCHES p.l.c.

APPROVALS RELATING TO THE SWITCH/NEON REF:

H8553VB

AUTHORITY	COUNTRY	STATUS	REFERENCE	PARAMETERS		
				VOLTAGE	CURRENT	TEMP ^o
BEAB	U.K.	S				
C.B.	-					
KEMA	Netherlands	S				
SEMKO	Sweden	A	8744034	250V	6(4)A	100C
DEMKO	Denmark	A	89134	250V	6(4)A	100C
NEMKO	Norway	A	M62662/01-2	250V	6(4)A	100C
VDE	West Germany	A	48464	250V	6(4)A	100C
F.L.	Finland	A	098936-01	250V	6(4)A	100C
U.L.	U.S.A.	A	E45221	250V	6A	
CSA	Canada	A	LR10990	250V	6A	
OVE	Austria	S				
SEV	Switzerland	A	8810046801	250V	6(4)A	100C
UTE	France	A	19806/807	250V	6(4)A	100C
.J.	Japan	N				

ARCOLECTRIC SWITCHES p.l.c.

APPROVALS RELATING TO THE SWITCH/NEON REF:

H8550VB

AUTHORITY	COUNTRY	STATUS	REFERENCE	PARAMETERS		
				VOLTAGE	CURRENT	TEMP ^o
BEAB	U.K.	A	126349 CS0018	250V	6(4)A	100C
C.B.	-					
KEMA	Netherlands	A	2053.87	250V	6(1)A	85C
SEMKO	Sweden	A	8744034	250V	6(4)A	100C
DEMKO	Denmark	A	89134	250v	6(4)A	100C
NEMKO	Norway	A	M62662	250V	6(4)A	100C
VDE	West Germany	A	48464	250V	6(4)A	100C
F.I.	Finland	A	098936.01	250V	6(4)A	100C
U.L.	U.S.A.	A	E45221	250V	6A	
CSA	Canada	A	LR10990	250V	6A	
OVE	Austria	A	19457/E	250V	6(1)A	85C
SEV	Switzerland	A	88 10046801	250V	6(4)A	100C
UTE	France	A	19806/807	250V	6(1)A	85C
.J.	Japan	N				