

**AK5703****4-Channel 24-bit ADC with PLL & MIC-AMP****GENERAL DESCRIPTION**

The AK5703 is a 4-channel 24-bit A/D converter with programmable microphone amplifiers and ALC (Automatic Level Control) circuit. It is designed for consumer microphone array applications. An integrated PLL operates from a wide variety of clocks, enabling high design flexibility. Microphone power outputs are included for biasing external microphones. Wide dynamic range is achieved, at 83dB with a microphone gain setting of +30dB. The AK5703 is packaged in a space-saving 28-pin QFN package.

FEATURES

1. **Recording Function**
 - 4-Channel ADC
 - Full-differential or Single-ended Input
 - Microphone Amplifier (+36dB/+30dB/+24dB/+18dB/+15dB/+12dB/+8dB/0dB)
 - Input Voltage: 1.8Vpp@AVDD=3.0V (= 0.6 x AVDD)
 - ADC Performance:
 - S/(N+D): 85dB, DR, S/N: 96dB@MGAIN=0dB, Single-ended Input
 - S/(N+D): 78dB, DR, S/N: 83dB@MGAIN=+30dB, Full Differential Input
 - Digital HPF for DC-offset cancellation (fc=3.4Hz@fs=44.1kHz)
 - Microphone Sensitivity Correction (+3dB ~ -3dB, 0.75dB Step)
 - Digital ALC (Automatic Level Control)
 - Input Digital Volume (+36dB ~ -52.5dB, 0.375dB Step, Mute)
 - Programmable Output Data Delay
 - Delay Time: 0 to 64/64fs (1/64fs Step)
2. **Sampling Frequency:**
 - PLL Slave Mode (BICK pin): 8kHz ~ 48kHz
 - PLL Slave Mode (MCKI pin):
 - 8kHz, 11.025kHz, 12kHz, 16kHz, 22.05kHz, 24kHz, 32kHz, 44.1kHz, 48kHz
 - PLL Master Mode:
 - 8kHz, 11.025kHz, 12kHz, 16kHz, 22.05kHz, 24kHz, 32kHz, 44.1kHz, 48kHz
 - EXT Master/Slave Mode:
 - 8kHz ~ 48kHz (256fs), 8kHz ~ 24kHz (512fs), 8kHz ~ 12kHz (1024fs)
3. **PLL Input Clock:**
 - MCKI pin:
 - 27MHz, 26MHz, 24MHz, 19.2MHz, 13.5MHz, 13MHz, 12.288MHz, 12MHz, 11.2896MHz
 - BICK pin: 32fs/64fs
4. **Master/Slave Mode**
5. **Audio Interface Format: MSB First, 2's complement**
 - 24/16-bit MSB justified, 24/16-bit I²S, TDM Mode
6. **μP I/F: 3-wire Serial Control or I²C Bus (Ver 1.0, 400kHz Mode)**
7. **Power Supply:**
 - AVDD: 2.4 ~ 3.6V
 - DVDD: 1.6 ~ 1.98V
 - TVDD: 1.6 or (DVDD-0.2) ~ 3.6V
8. **Power Supply Current: 9.0mA (EXT Slave Mode)**
9. **Ta = -30 ~ 85°C**
10. **Package: 28pin QFN (4mm x 4mm, 0.4mm pitch)**

■ Block Diagram

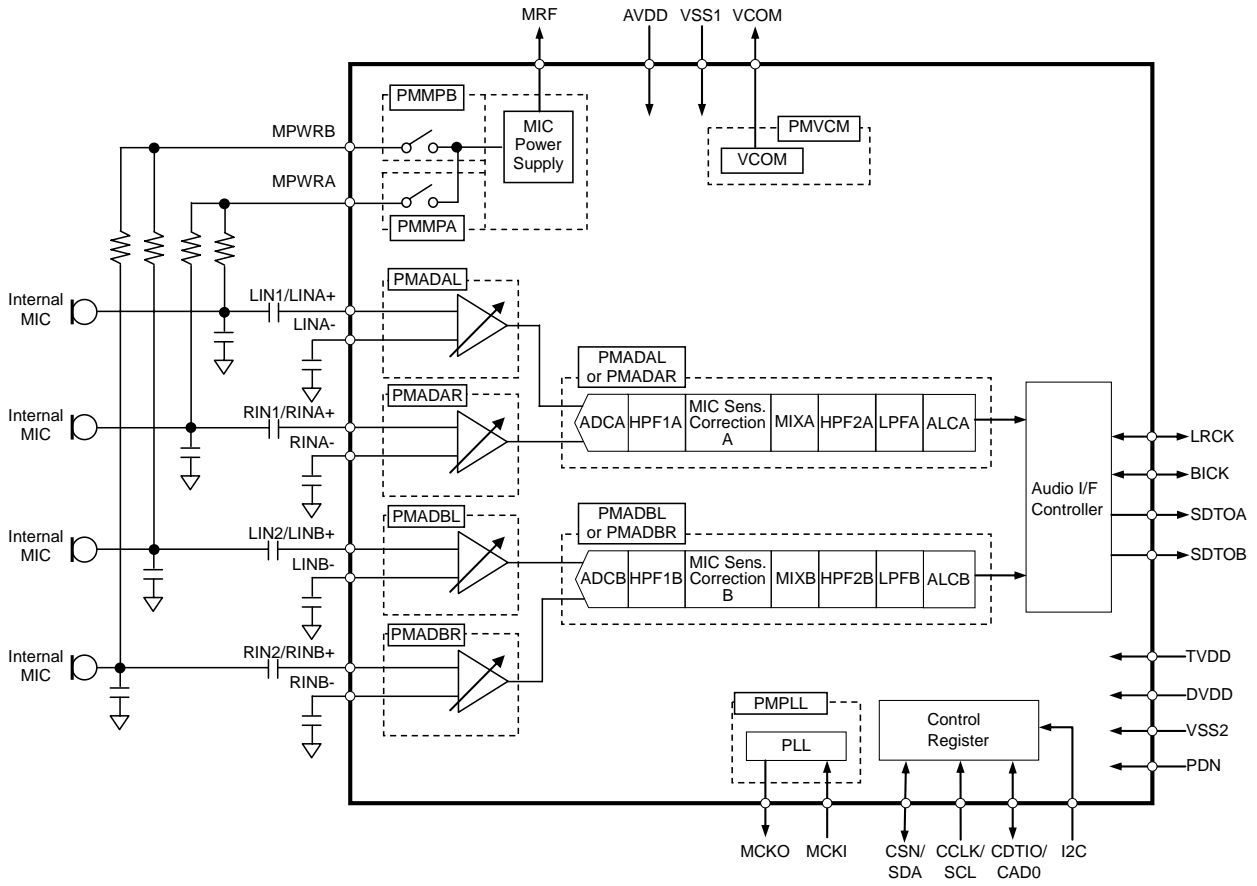

Figure 1. Block Diagram

■ **Ordering Guide**

AK5703EN
AKD5703

-30 ~ +85°C 28pin QFN (0.4mm pitch)
Evaluation Board for AK5703

■ **Pin Layout**

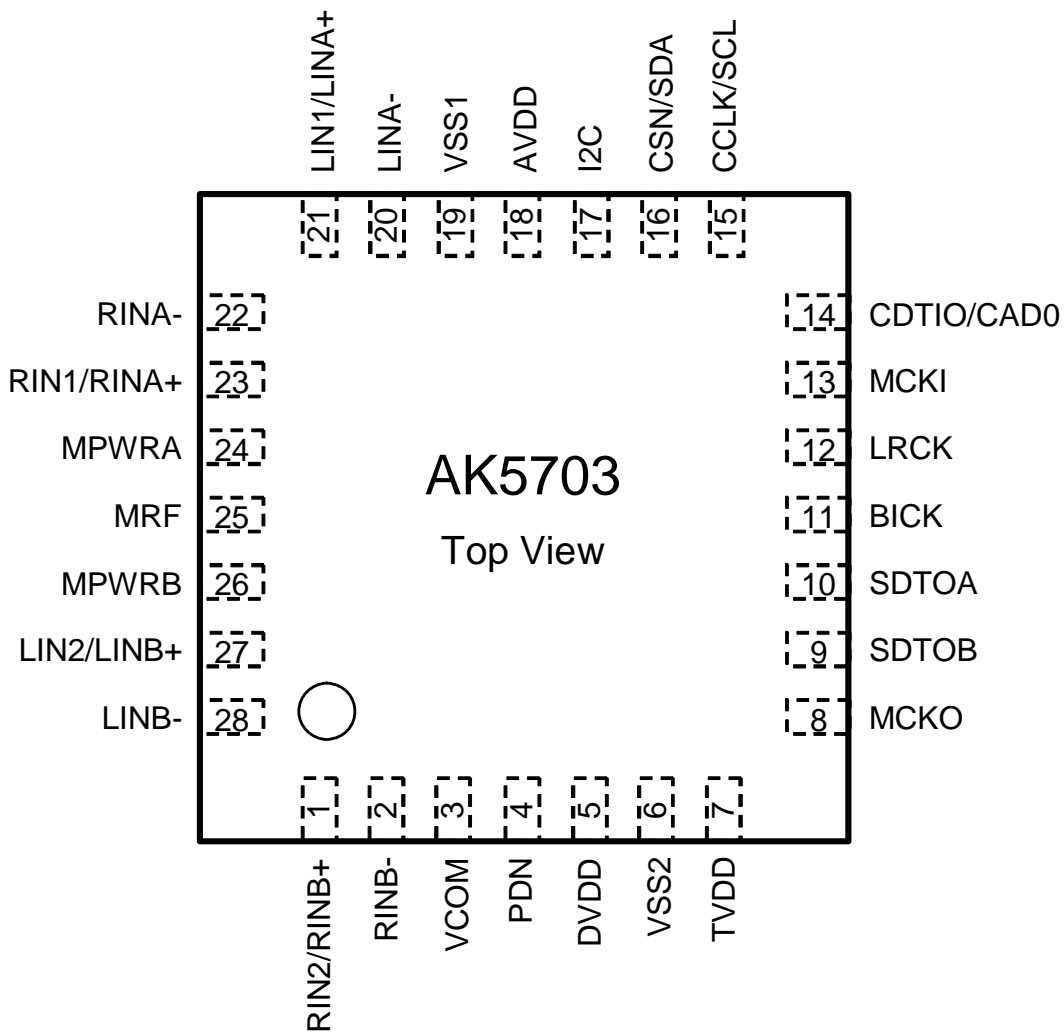

■ Comparison with AK5702

Function		AK5702	AK5703
ADC Resolution		16-bit	24-bit
3:1 Stereo Input Selector		Yes	No
MIC Amplifier	Gain	+36dB, +30dB, +15dB, 0dB	+36dB, +30dB, +24dB, +18dB, +15dB, +12dB, +8dB, 0dB
	Input Resistance	30k Ω @MGAIN=+15dB, +30dB, +36dB	100k Ω
DR, S/N (Full Differential Input)		74dB@MGAIN=+30dB	83dB@MGAIN=+30dB
Audio Interface	DSP Mode	Yes	No
	TDM Mode	Yes	Yes
	Cascade TDM Mode	Yes	No
MIC Sensitivity Correction		No	Yes (+3dB ~ -3dB)
Programmable Output Data Delay		No	Yes (0 ~ 64/64fs)
PLL	LRCK Reference	Yes	No
	VCOC pin	Yes	No
Package		32pin QFN (5mm x 5mm, 0.5mm pitch)	28pin QFN (4mm x 4mm, 0.4mm pitch)

PIN/FUNCTION			
No.	Pin Name	I/O	Function
1	RIN2	I	Rch Analog Input 2 Pin (MDIFB bit = "0": Single-ended Input)
	RINB+	I	Rch Positive Input B Pin (MDIFB bit = "1": Full-differential Input)
2	RINB-	I	Rch Negative Input B Pin (MDIFB bit = "0": Single-ended Input) This pin must be connected to VSS1 with a capacitor in series. (Refer to Figure 50)
			Rch Negative Input B Pin Rch Negative Input B Pin
3	VCOM	O	Common Voltage Output Pin, 0.5 x AVDD Bias voltage of ADC inputs. This pin must be connected to VSS1 with 1μF±50% capacitor in series.
4	PDN	I	Power-Down Mode Pin "H": Power-up, "L": Power-down, reset and initializes the control register.
5	DVDD	-	Digital Power Supply Pin, 1.6 ~ 1.98V
6	VSS2	-	Digital Ground Pin
7	TVDD	-	Digital I/O Power Supply Pin, 1.6 ~ 3.6V
8	MCKO	O	Master Clock Output Pin
9	SDTOB	O	ADCB/TDM Audio Serial Data Output Pin
10	SDTOA	O	ADCA Audio Serial Data Output Pin
11	BICK	I/O	Audio Serial Data Clock Pin
12	LRCK	I/O	Input / Output Channel Clock Pin
13	MCKI	I	External Master Clock Input Pin
14	CDTIO	I/O	Control Data Input/Output Pin (I2C pin = "L": 3-wire Serial Mode)
	CAD0	I	Chip Address 0 Select Pin (I2C pin = "H": I ² C Bus Mode)
15	CCLK	I	Control Data Clock Pin (I2C pin = "L": 3-wire Serial Mode)
	SCL	I	Control Data Clock Pin (I2C pin = "H": I ² C Bus Mode)
16	CSN	I	Chip Select Pin (I2C pin = "L": 3-wire Serial Mode)
	SDA	I/O	Control Data Input Pin (I2C pin = "H": I ² C Bus Mode)
17	I2C	I	Control Mode Select Pin "H": I ² C, "L": 3-wire serial
18	AVDD	-	Analog Power Supply Pin, 2.4 ~ 3.6V
19	VSS1	-	Analog Ground Pin
20	LINA-	I	Lch Negative Input A Pin (MDIFA bit = "0": Single-ended Input) This pin must be connected to VSS1 with a capacitor in series. (Refer to Figure 50)
			Lch Negative Input A Pin (MDIFA bit = "1": Full-differential Input)
21	LIN1	I	Lch Analog Input 1 Pin (MDIFA bit = "0": Single-ended Input)
			Lch Positive Input A Pin (MDIFA bit = "1": Full-differential Input)
22	RINA-	I	Rch Negative Input A Pin (MDIFA bit = "0": Single-ended Input) This pin must be connected to VSS1 with a capacitor in series. (Refer to Figure 50)
			Rch Negative Input A Pin (MDIFB bit = "1": Full-differential Input)
23	RIN1	I	Rch Analog Input 1 Pin (MDIFA bit = "0": Single-ended Input)
			Rch Positive Input A Pin (MDIFA bit = "1": Full-differential Input)
24	MPWRA	O	Microphone Power Supply A Pin
25	MRF	O	Microphone Power Supply Ripple Filter Pin This pin must be connected to VSS1 with 1μF±50% capacitor in series.
26	MPWRB	O	Microphone Power Supply B Pin
27	LIN2	I	Lch Analog Input 2 Pin (MDIFB bit = "0": Single-ended Input)
			Lch Positive Input B Pin (MDIFB bit = "1": Full-differential Input)
28	LINB-	I	Lch Negative Input B Pin (MDIFB bit = "0": Single-ended Input) This pin must be connected to VSS1 with a capacitor in series. (Refer to Figure 50)
			Lch Negative Input B Pin (MDIFB bit = "1": Full-differential Input)

Note 1. All input pins except analog input pins (LIN1-2, RIN1-2, LINA+/-, RINA+/-, LINB+/-, RINB+/-) must not be allowed to float.

■ Handling of Unused Pin

The unused I/O pins must be connected appropriately.

Classification	Pin Name	Setting
Analog	MPWRA, MPWRB, MRF, LIN1/LINA+, LINA-, RIN1/RINA+, RINA-, LIN2/LINB+, LINB-, RIN2/RINB+, RINB-	Open
	LINA-, RINA-, LINB-, RINB- (When single-ended inputs are used.)	Connect to VSS1 with a capacitor in series.
Digital	SDTOA, SDTOB, MCKO	Open
	MCKI	Connect to VSS2

ABSOLUTE MAXIMUM RATINGS

(VSS1, VSS2 = 0V; Note 2)

Parameter	Symbol	min	max	Unit
Power Supplies:				
Analog	AVDD	-0.3	6.0	V
Digital	DVDD	-0.3	2.5	V
Digital I/O	TVDD	-0.3	6.0	V
Input Current, Any Pin Except Supplies	IIN	-	±10	mA
Analog Input Voltage (Note 3)	VINA	-0.3	AVDD+0.3	V
Digital Input Voltage (Note 4)	VIND	-0.3	TVDD+0.3	V
Ambient Temperature (powered applied)	Ta	-30	85	°C
Storage Temperature	Tstg	-65	150	°C

Note 2. All voltages are with respect to ground. VSS1 and VSS2 must be connected to the same analog ground plane.

Note 3. LIN1/LINA+, LINA-, RIN1/RINA+, RINA-, LIN2/LINB+, LINB-, RIN2/RINB+, RINB- pins

Note 4. PDN, CSN/SDA, CCLK/SCL, CDTIO/CAD0, MCKI, LRCK, BICK, I2C pins

Pull-up resistors at SDA and SCL pins should be connected to (TVDD+0.3)V or less voltage.

WARNING: Operation at or beyond these limits may result in permanent damage to the device.

Normal operation is not guaranteed at these extremes.

RECOMMENDED OPERATING CONDITIONS

(VSS1, VSS2=0V; Note 2)

Parameter	Symbol	min	typ	max	Unit
Power Supplies					
Analog	AVDD	2.4	3.0	3.6	V
Digital	DVDD	1.6	1.8	1.98	V
Digital I/O (Note 6)	TVDD	1.6 or DVDD-0.2	3.0	3.6	V

Note 2. All voltages are with respect to ground. VSS1 and VSS2 must be connected to the same analog ground plane.

Note 5. The power-up sequence between AVDD, DVDD and TVDD is not critical. The PDN pin must be "L" upon power-up, and should be changed to "H" after all power supplies are supplied to avoid an internal circuit error.

Note 6. The minimum value is higher voltage between DVDD-0.2V and 1.6V.

*** When TVDD is powered ON and the PDN pin is "L", AVDD or DVDD can be powered ON/OFF. The PDN pin must be set to "H" after all power supplies are ON when the AK5703 is powered-up from power-down state.**

* AKM assumes no responsibility for the usage beyond the conditions in this datasheet.

ANALOG CHARACTERISTICS

(Ta=25°C; AVDD=TVDD=3.0V, DVDD=1.8V; VSS1=VSS2=0V; EXT Slave Mode; MCKI=11.2896MHz, fs=44.1kHz, BICK=64fs; Signal Frequency=1kHz; 24bit Data; Measurement bandwidth =20Hz ~ 20kHz; unless otherwise specified)

Parameter		min	typ	max	Unit
Microphone Amplifier: LIN1/RIN1/LIN2/RIN2 pins					
Input Resistance		70	100	130	kΩ
Gain	MGAIN2-0 bits = "000"	-1	0	+1	dB
	MGAIN2-0 bits = "001"	+7	+8	+9	dB
	MGAIN2-0 bits = "010"	+11	+12	+13	dB
	MGAIN2-0 bits = "011"	+14	+15	+16	dB
	MGAIN2-0 bits = "100"	+17	+18	+19	dB
	MGAIN2-0 bits = "101"	+23	+24	+25	dB
	MGAIN2-0 bits = "110"	+29	+30	+31	dB
	MGAIN2-0 bits = "111"	+35	+36	+37	dB
Microphone Power Supply: MPWRA, MPWRB pins					
Output Voltage (Note 7)		2.16	2.40	2.64	V
Output Noise Level (A-weighted)		-	-114	-	dBV
PSRR (fin = 1kHz) (Note 8)		-	70	-	dB
Load Resistance		0.5	-	-	kΩ
Load Capacitance		-	-	30	pF
ADC Analog Input Characteristics: LIN1/RIN1/LIN2/RIN2 pins (Single-ended Input) → ADC → Programmable Filter (IVOL=0dB, ALC=OFF) → SDTOA/SDTOB					
Resolution		-	-	24	Bits
Input Voltage (Note 9)	MGAIN= +30dB	0.048	0.057	0.065	Vpp
	MGAIN= 0dB	1.53	1.80	2.07	Vpp
S/(N+D) (-1dBFS)	MGAIN= +30dB	68	78	-	dB
	MGAIN= 0dB	-	85	-	dB
	MGAIN= +30dB (Full Differential Input)	-	78	-	dB
D-Range (-60dBFS, A-weighted)	MGAIN= +30dB	73	83	-	dB
	MGAIN= 0dB	-	96	-	dB
	MGAIN= +30dB (Full Differential Input)	-	83	-	dB
S/N (A-weighted)	MGAIN= +30dB	73	83	-	dB
	MGAIN= 0dB	-	96	-	dB
	MGAIN= +30dB (Full Differential Input)	-	83	-	dB
Interchannel Isolation	MGAIN= +30dB	70	80	-	dB
	MGAIN= 0dB	-	100	-	dB
Interchannel Gain Mismatch	MGAIN= +30dB	-	0	1.0	dB
	MGAIN= 0dB	-	0	0.5	dB

Note 7. The output voltage is proportional to AVDD. (typ. 0.8 x AVDD V)

Note 8. PSRR is applied to AVDD with 100mpVpp sine wave.

Note 9. The full-scale input voltage is proportional to AVDD.

Single-ended Input: $V_{in} = 0.6 \times AVDD \text{ Vpp(} \text{typ)}$

Full Differential Input: $V_{in} = (IN+) - (IN-) = 0.6 \times AVDD \text{ Vpp(} \text{typ)}$

Parameter		min	typ	max	Unit
Power Supply Current:					
Power Up (PDN pin = "H", All Circuits Power-up)					
AVDD + DVDD + TVDD	(Note 10)	-	9.0	-	mA
	(Note 11)	-	12.0	18.0	mA
Power Down (PDN pin = "L") (Note 12)					
AVDD + DVDD + TVDD		-	0	10	μA

Note 10. When EXT Slave Mode (MCKI=11.2896MHz, fs=44.1kHz), and PMADAL = PMADAR = PMADBL = PMADBR = PMVCM = PMMPA = PMMPB bits = "1", PMPLL = M/S = MCKO bits = "0", TDM1-0 bits = "00". In this case, the MPWRA and MPWRB pins output 0mA.

AVDD=7.1mA(typ), DVDD=1.7mA(typ), TVDD=0.2mA(typ).

Note 11. When PLL Master Mode (MCKI=12MHz, fs=44.1kHz), and PMADAL = PMADAR = PMADBL = PMADBR = PMVCM = PMMPA = PMMPB = PMPLL = M/S = MCKO bits = "1", TDM1-0 bits = "11". In this case, the MPWRA and MPWRB pins output 0mA.

AVDD=7.7mA(typ), DVDD=1.8mA(typ), TVDD=2.5mA(typ).

Note 12. All digital input pins are fixed to TVDD or VSS2.

FILTER CHARACTERISTICS

(Ta=25°C; AVDD=2.4 ~ 3.6V; DVDD=1.6 ~ 1.98V; TVDD=1.6 ~ 3.6V; fs=44.1kHz)

Parameter	Symbol	min	typ	max	Unit	
ADC Digital Filter (Decimation LPF):						
Passband (Note 13)	±0.16dB	PB	0	-	17.3	kHz
	-0.66dB		-	19.4	-	kHz
	-1.1dB		-	19.9	-	kHz
	-7.1dB		-	22.1	-	kHz
Stopband (Note 13)	SB	26.1	-	-	kHz	
Passband Ripple	PR	-	-	±0.16	dB	
Stopband Attenuation	SA	73	-	-	dB	
Group Delay (Note 14)	GD	-	19	-	1/fs	
Group Delay Distortion	ΔGD	-	0	-	μs	
ADC Digital Filter (HPF): HPFADA=HPFADB bits = "1", HPFA1-0= HPFB1-0 bits = "00"						
Frequency Response (Note 13)	-3.0dB	FR	-	3.4	-	Hz
	-0.5dB		-	10	-	Hz
	-0.1dB		-	22	-	Hz

Note 13. The passband and stopband frequencies scale with fs (system sampling rate). Each response refers to that of 1kHz.

Note 14. A calculating delay time which induced by digital filtering. This time is from the input of an analog signal to the setting of 24-bit data of both channels to the ADC output register.

DC CHARACTERISTICS

(Ta=25°C; AVDD=2.4 ~ 3.6V; DVDD=1.6 ~ 1.98V; TVDD=1.6 ~ 3.6V)

Parameter	Symbol	min	typ	max	Unit
Audio Interface & Serial μP Interface (CDTIO/CAD0, CSN/SDA, CCLK/SCL, I2C, PDN, BICK, LRCK, MCKI pins)					
High-Level Input Voltage (TVDD ≥ 2.2V)	VIH	70%TVDD	-	-	V
(TVDD < 2.2V)		80%TVDD	-	-	V
Low-Level Input Voltage (TVDD ≥ 2.2V)	VIL	-	-	30%TVDD	V
(TVDD < 2.2V)		-	-	20%TVDD	V
Audio Interface & Serial μP Interface (CDTIO, SDA, MCKO, BICK, LRCK, SDTOA, SDTOB pins Output)					
High-Level Output Voltage (Iout = -80μA)	VOH	TVDD-0.2	-	-	V
Low-Level Output Voltage (Except SDA pin : Iout = 80μA)	VOL1	-	-	0.2	V
(SDA pin, 2.0V ≤ TVDD ≤ 3.6V: Iout = 3mA)	VOL2	-	-	0.4	V
(SDA pin, 1.6V ≤ TVDD < 2.0V: Iout = 3mA)	VOL2	-	-	20%TVDD	V
Input Leakage Current	Iin	-	-	±10	μA

SWITCHING CHARACTERISTICS

(Ta=25°C; AVDD=2.4 ~ 3.6V; DVDD=1.6 ~ 1.98V; TVDD=1.6 ~ 3.6V; CL=20pF)

Parameter	Symbol	min	typ	max	Unit	
PLL Master Mode (PLL Reference Clock = MCKI pin)						
MCKI Input Timing						
Frequency	fCLK	11.2896	-	27	MHz	
Pulse Width Low	tCLKL	0.4/fCLK	-	-	s	
Pulse Width High	tCLKH	0.4/fCLK	-	-	s	
MCKO Output Timing						
Frequency	fMCK	0.256	-	12.288	MHz	
Duty Cycle	dMCK	40	50	60	%	
LRCK Output Timing						
Frequency	fs	-	Table 6	-	kHz	
Stereo Mode: Duty Cycle	Duty	-	50	-	%	
TDM64, TDM128 Mode:						
I ² S compatible: Pulse Width Low	tLRCKL	-	1/(4fs)	-	s	
MSB justified: Pulse Width High	tLRCKH	-	1/(4fs)	-	s	
BICK Output Timing						
Period	BCKO1-0 bits = "00"	tBCK	-	1/(32fs)	s	
	BCKO1-0 bits = "01"	tBCK	-	1/(64fs)	s	
	BCKO1-0 bits = "10" (TDM128 Mode)	tBCK	-	1/(128fs)	s	
Duty Cycle	dBCK	-	50	-	%	
PLL Slave Mode (PLL Reference Clock = MCKI pin)						
MCKI Input Timing						
Frequency	fCLK	11.2896	-	27	MHz	
Pulse Width Low	tCLKL	0.4/fCLK	-	-	s	
Pulse Width High	tCLKH	0.4/fCLK	-	-	s	
MCKO Output Timing						
Frequency	fMCK	0.256	-	12.288	MHz	
Duty Cycle	dMCK	40	50	60	%	
LRCK Input Timing						
Frequency	fs	-	Table 6	-	kHz	
Stereo Mode: Duty Cycle	Duty	45	-	55	%	
TDM64 Mode:						
I ² S compatible: Pulse Width Low	tLRCKL	1/(64fs)	-	63/(64fs)	s	
MSB justified: Pulse Width High	tLRCKH	1/(64fs)	-	63/(64fs)	s	
TDM128 Mode:						
I ² S compatible: Pulse Width Low	tLRCKL	1/(128fs)	-	127/(128fs)	s	
MSB justified: Pulse Width High	tLRCKH	1/(128fs)	-	127/(128fs)	s	
BICK Input Timing						
Period	Stereo Mode	tBCK	1/(64fs)	-	1/(32fs)	s
	TDM64 Mode	tBCK	-	1/(64fs)	s	
	TDM128 Mode	tBCK	-	1/(128fs)	s	
Pulse Width Low	tBCKL	0.4 x tBCK	-	-	s	
Pulse Width High	tBCKH	0.4 x tBCK	-	-	s	

Parameter	Symbol	min	typ	max	Unit	
PLL Slave Mode (PLL Reference Clock = BICK pin)						
MCKO Output Timing						
Frequency	fMCK	0.256	-	12.288	MHz	
Duty Cycle	dMCK	40	50	60	%	
LRCK Input Timing						
Frequency	fs	8	-	48	kHz	
Stereo Mode: Duty Cycle	Duty	45	-	55	%	
TDM64 Mode:						
I ² S compatible: Pulse Width Low	tLRCKL	1/(64fs)	-	63/(64fs)	s	
MSB justified: Pulse Width High	tLRCKH	1/(64fs)	-	63/(64fs)	s	
TDM128 Mode:						
I ² S compatible: Pulse Width Low	tLRCKL	1/(128fs)	-	127/(128fs)	s	
MSB justified: Pulse Width High	tLRCKH	1/(128fs)	-	127/(128fs)	s	
BICK Input Timing						
Period	Stereo Mode		tBCK	-	1/(32fs)	s
	PLL3-0 bits = "0010"					
	PLL3-0 bits = "0011"		tBCK	-	1/(64fs)	s
	TDM64 Mode		tBCK	-	1/(64fs)	s
PLL3-0 bits = "0011"						
TDM128 Mode		tBCK	-	1/(128fs)	s	
PLL3-0 bits = "0001"						
Pulse Width Low		tBCKL	0.4 x tBCK	-	s	
Pulse Width High		tBCKH	0.4 x tBCK	-	s	
External Slave Mode						
MCKI Input Timing						
Frequency	256fs	fCLK	2.048	-	12.288	MHz
	512fs	fCLK	4.096	-	12.288	MHz
	1024fs	fCLK	8.192	-	12.288	MHz
Pulse Width Low		tCLKL	0.4/fCLK	-	s	
Pulse Width High		tCLKH	0.4/fCLK	-	s	
LRCK Input Timing						
Frequency	256fs	fs	8	-	48	kHz
	512fs	fs	8	-	24	kHz
	1024fs	fs	8	-	12	kHz
Stereo Mode: Duty Cycle		Duty	45	-	55	%
TDM64 Mode:						
I ² S compatible: Pulse Width Low		tLRCKL	1/(64fs)	-	63/(64fs)	s
MSB justified: Pulse Width High		tLRCKH	1/(64fs)	-	63/(64fs)	s
TDM128 Mode:						
I ² S compatible: Pulse Width Low		tLRCKL	1/(128fs)	-	127/(128fs)	s
MSB justified: Pulse Width High		tLRCKH	1/(128fs)	-	127/(128fs)	s
BICK Input Timing						
Period	Stereo Mode		tBCK	325.52	-	ns
	TDM Mode		tBCK	162.76	-	ns
Pulse Width Low	Stereo Mode		tBCKL	130	-	ns
	TDM Mode		tBCKL	65	-	ns
Pulse Width High	Stereo Mode		tBCKH	130	-	ns
	TDM Mode		tBCKH	65	-	ns

Parameter	Symbol	min	typ	max	Unit	
External Master Mode						
MCKI Input Timing						
Frequency	256fs	fCLK	2.048	-	12.288	MHz
	512fs	fCLK	4.096	-	12.288	MHz
	1024fs	fCLK	8.192	-	12.288	MHz
Pulse Width Low	tCLKL	0.4/fCLK	-	-	s	
Pulse Width High	tCLKH	0.4/fCLK	-	-	s	
LRCK Output Timing						
Frequency	fs	8	-	48	kHz	
Stereo Mode: Duty Cycle	Duty	-	50	-	%	
TDM64, TDM128 Mode:						
I ² S compatible: Pulse Width Low	tLRCKL	-	1/(4fs)	-	s	
MSB justified: Pulse Width High	tLRCKH	-	1/(4fs)	-	s	
BICK Output Timing						
Period	BCKO1-0 bits = "00"	tBCK	-	1/(32fs)	-	s
	BCKO1-0 bits = "01"	tBCK	-	1/(64fs)	-	s
	BCKO1-0 bits = "10"	tBCK	-	1/(128fs)	-	s
	(TDM128 Mode)					
Duty Cycle	dBCK	-	50	-	%	
Audio Interface Timing (Left justified & I²S)						
Master Mode						
BICK "↓" to LRCK Edge (Note 15)	tMBLR	-40	-	40	ns	
LRCK Edge to SDTO (MSB) (Except I ² S mode)	tLRD	-70	-	70	ns	
BICK "↓" to SDTO	tBSD	-70	-	70	ns	
Slave Mode						
LRCK Edge to BICK "↑" (Note 15)	tLRB	50	-	-	ns	
BICK "↑" to LRCK Edge (Note 15)	tBLR	50	-	-	ns	
LRCK Edge to SDTO (MSB) (Except I ² S mode)	tLRD	-	-	80	ns	
BICK "↓" to SDTO	tBSD	-	-	80	ns	
Audio Interface Timing (TDM64 Mode)						
Master Mode						
BICK "↓" to LRCK	tMBLR	-40	-	40	ns	
BICK "↓" to SDTOB (Note 16)	tBSD	-70	-	70	ns	
Slave Mode						
LRCK Edge to BICK "↑" (Note 15)	tLRB	50	-	-	ns	
BICK "↑" to LRCK Edge (Note 15)	tBLR	50	-	-	ns	
BICK "↓" to SDTOB (Note 16)	tBSD	-	-	80	ns	
Audio Interface Timing (TDM128 Mode)						
Master Mode						
BICK "↓" to LRCK	tMBLR	-24	-	24	ns	
BICK "↓" to SDTOB (Note 16)	tBSD	-40	-	40	ns	
Slave Mode						
LRCK Edge to BICK "↑" (Note 15)	tLRB	40	-	-	ns	
BICK "↑" to LRCK Edge (Note 15)	tBLR	40	-	-	ns	
BICK "↓" to SDTOB (Note 16)	tBSD	-	-	50	ns	

Note 15. BICK rising edge must not occur at the same time as LRCK edge.

Note 16. SDTOA is fixed to "L".

Parameter	Symbol	min	typ	max	Unit
Control Interface Timing (3-wire mode):					
CCLK Period	tCCK	200	-	-	ns
CCLK Pulse Width Low	tCCKL	80	-	-	ns
Pulse Width High	tCCKH	80	-	-	ns
CDTIO Setup Time	tCDS	40	-	-	ns
CDTIO Hold Time	tCDH	40	-	-	ns
CSN "H" Time	tCSW	150	-	-	ns
CSN Edge to CCLK "↑" (Note 17)	tCSS	50	-	-	ns
CCLK "↑" to CSN Edge (Note 17)	tCSH	50	-	-	ns
CCLK "↓" to CDTIO (at Read Command)	tDCD	-	-	70	ns
CSN "↑" to CDTIO (Hi-Z) (at Read Command) (Note 19)	tCCZ	-	-	70	ns
Control Interface Timing (I²C Bus mode) (Note 18)					
SCL Clock Frequency	fSCL	-	-	400	kHz
Bus Free Time Between Transmissions	tBUF	1.3	-	-	μs
Start Condition Hold Time (prior to first clock pulse)	tHD:STA	0.6	-	-	μs
Clock Low Time	tLOW	1.3	-	-	μs
Clock High Time	tHIGH	0.6	-	-	μs
Setup Time for Repeated Start Condition	tSU:STA	0.6	-	-	μs
SDA Hold Time from SCL Falling (Note 20)	tHD:DAT	0	-	-	μs
SDA Setup Time from SCL Rising	tSU:DAT	0.1	-	-	μs
Rise Time of Both SDA and SCL Lines	tR	-	-	0.3	μs
Fall Time of Both SDA and SCL Lines	tF	-	-	0.3	μs
Setup Time for Stop Condition	tSU:STO	0.6	-	-	μs
Pulse Width of Spike Noise Suppressed by Input Filter	tSP	0	-	50	ns
Capacitive Load on Bus	Cb	-	-	400	pF
Power-down & Reset Timing					
PDN Accept Pulse Width (Note 21)	tAPD	1.0	-	-	μs
PDN Reject Pulse Width (Note 21)	tRPD	-	-	50	ns
PMADAL or PMADAR or PMADBL or PMADBR "↑" to SDTO valid (Note 22)					
ADRSTA/B1-0 bits = "00"	tPDV	-	1059	-	1/fs
ADRSTA/B1-0 bits = "01"	tPDV	-	267	-	1/fs
ADRSTA/B1-0 bits = "10"	tPDV	-	2115	-	1/fs
ADRSTA/B1-0 bits = "11"	tPDV	-	531	-	1/fs

Note 17. CCLK rising edge must not occur at the same time as CSN edge.

Note 18. I²C-bus is a trademark of NXP B.V.

Note 19. R_L=1kΩ/10% change (pull-up to TVDD)

Note 20. Data must be held for sufficient time to bridge the 300 ns transition time of SCL.

Note 21. The AK5703 can be reset by bringing the PDN pin "L" upon power-up. The PDN pin must held "L" for more than 1μs for a certain reset. The AK5703 is not reset by the "L" pulse less than 50ns.

Note 22. This is the count of LRCK "↑" from the PMADAL, PMADAR, PMADBL or PMADBR bit = "1".

■ Timing Diagram

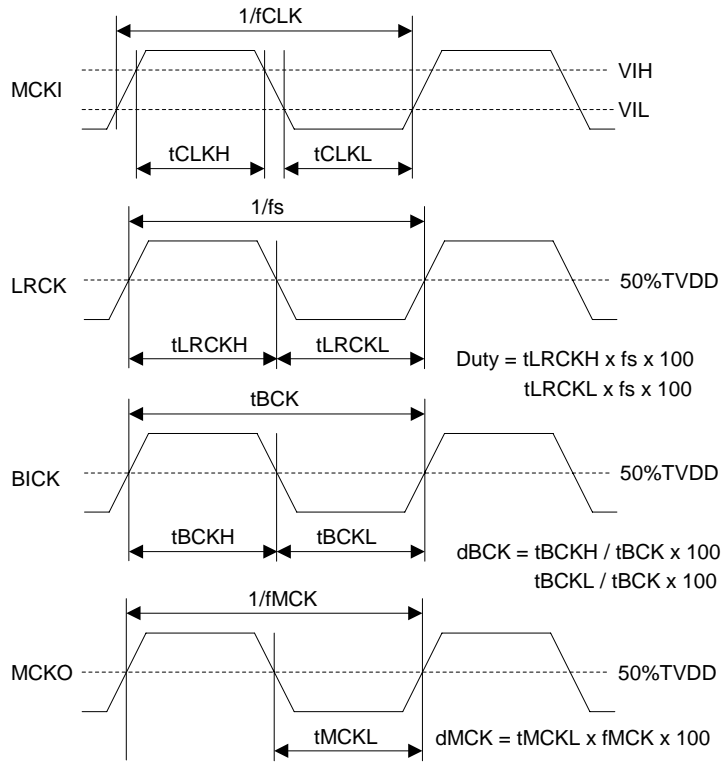

Note 23. MCKO is not available at EXT Master Mode.

Figure 2. Clock Timing (PLL/EXT Master mode)

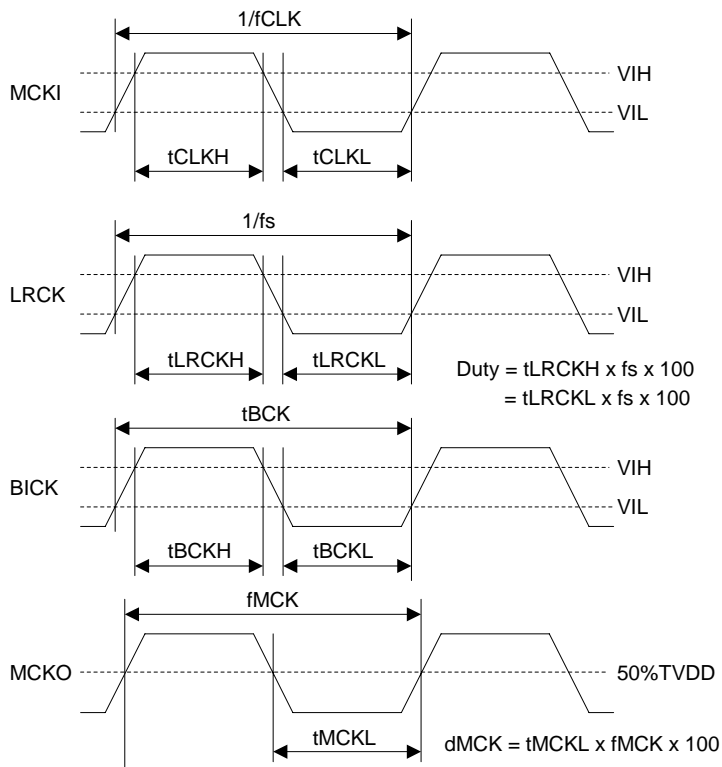

Note 24. The MCKI pin is "L" level when PLL reference clock is the BICK pin.

Figure 3. Clock Timing (PLL Slave mode)

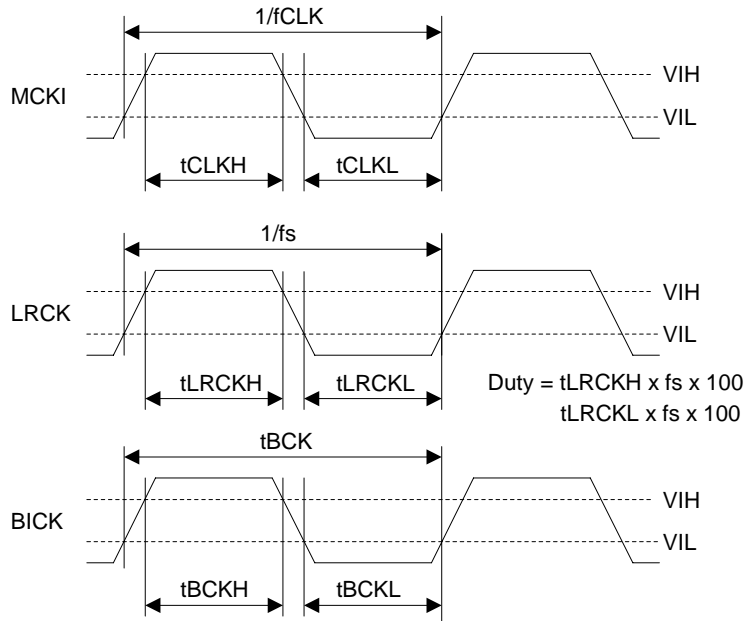

Figure 4. Clock Timing (EXT Slave mode)

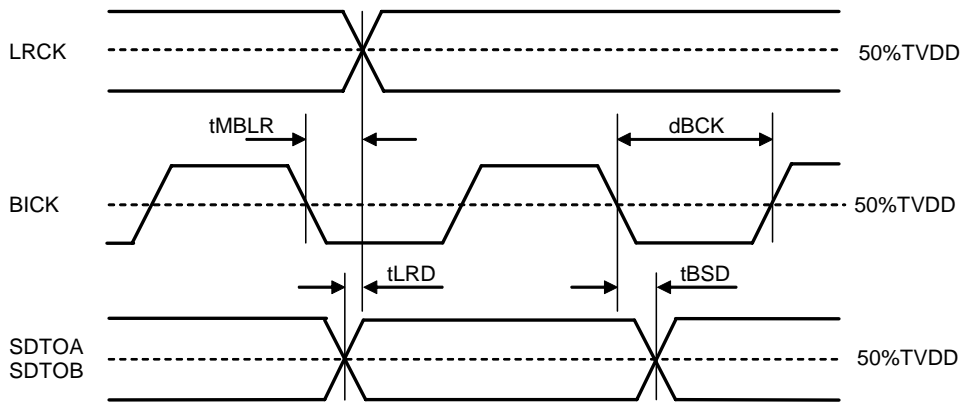

Figure 5. Audio Interface Timing (PLL/EXT Master mode & Normal Mode)

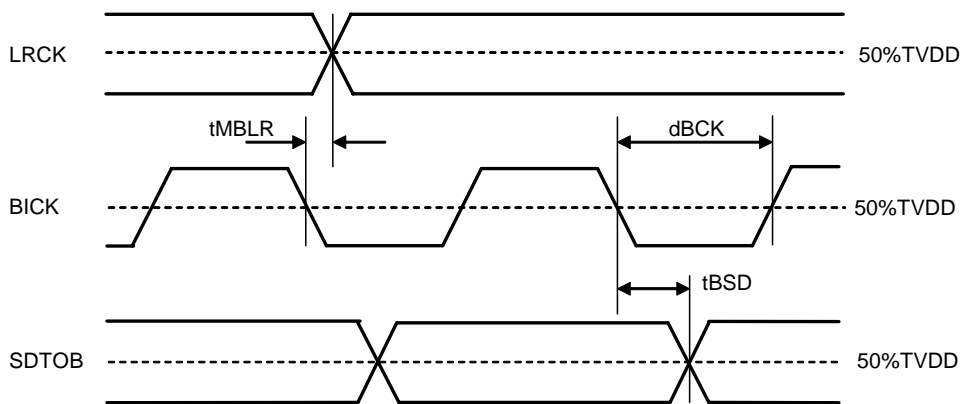

Figure 6. Audio Interface Timing (PLL/EXT Master mode & TDM mode)

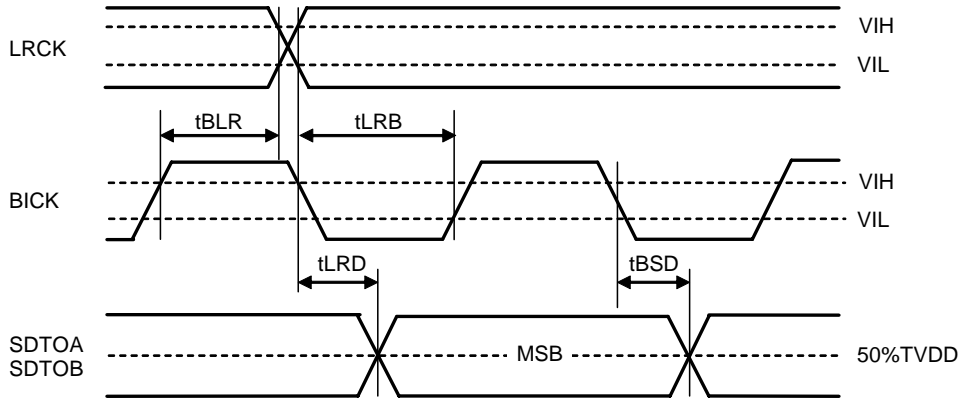

Figure 7. Audio Interface Timing (PLL/EXT Slave mode & Normal mode)

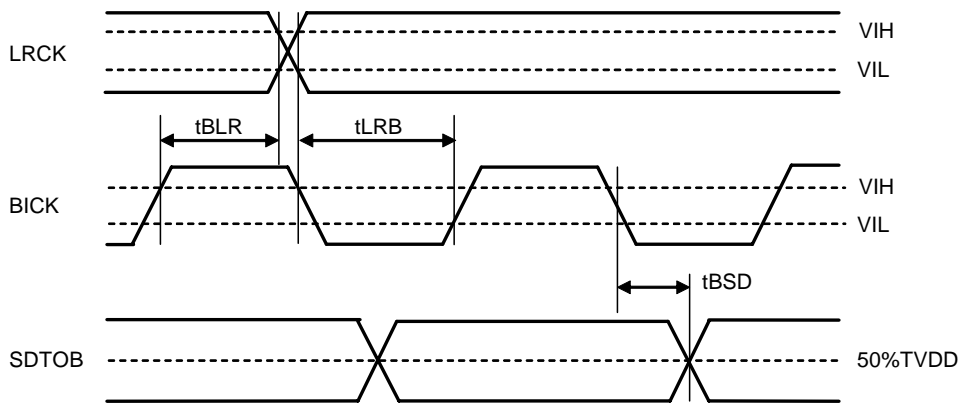

Figure 8. Audio Interface Timing (PLL/EXT Slave mode & TDM mode)

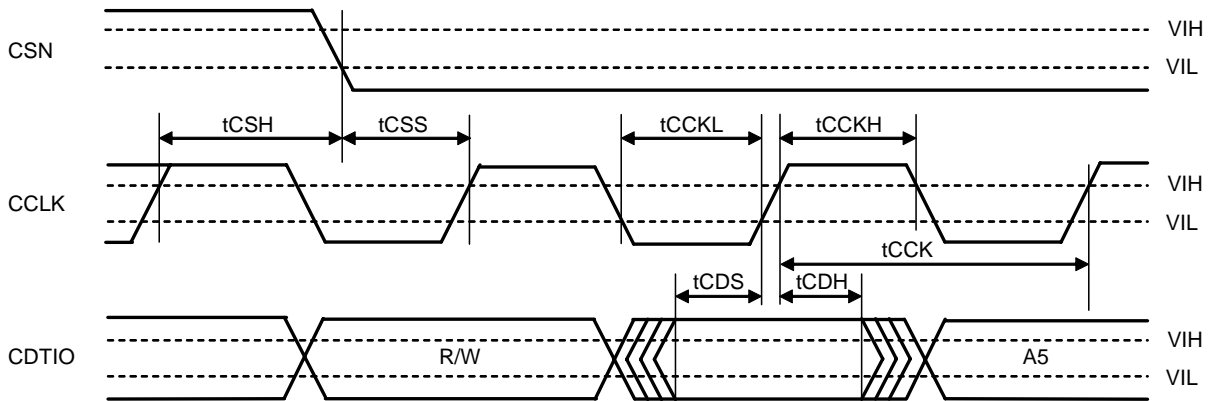

Figure 9. WRITE Command Input Timing

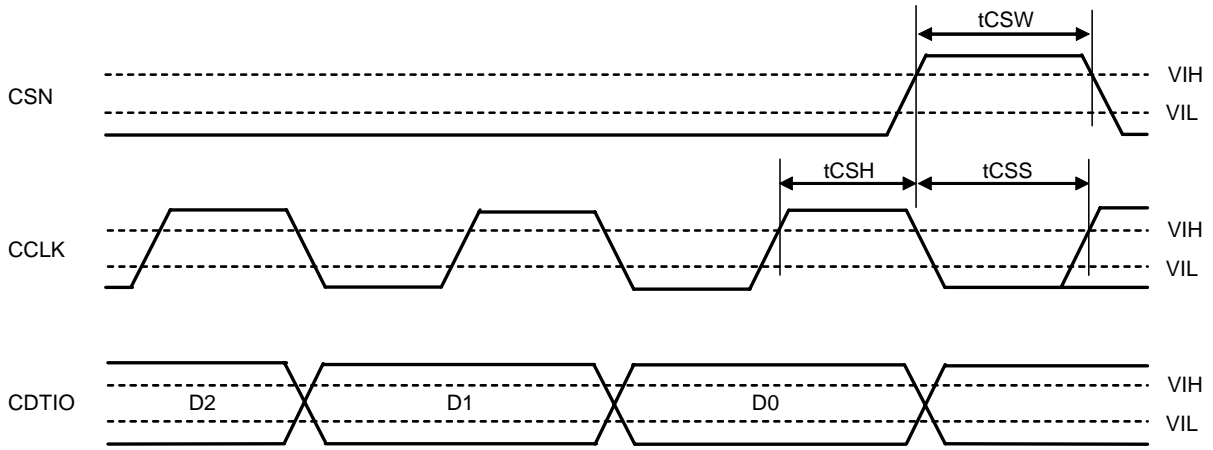

Figure 10. WRITE Data Input Timing

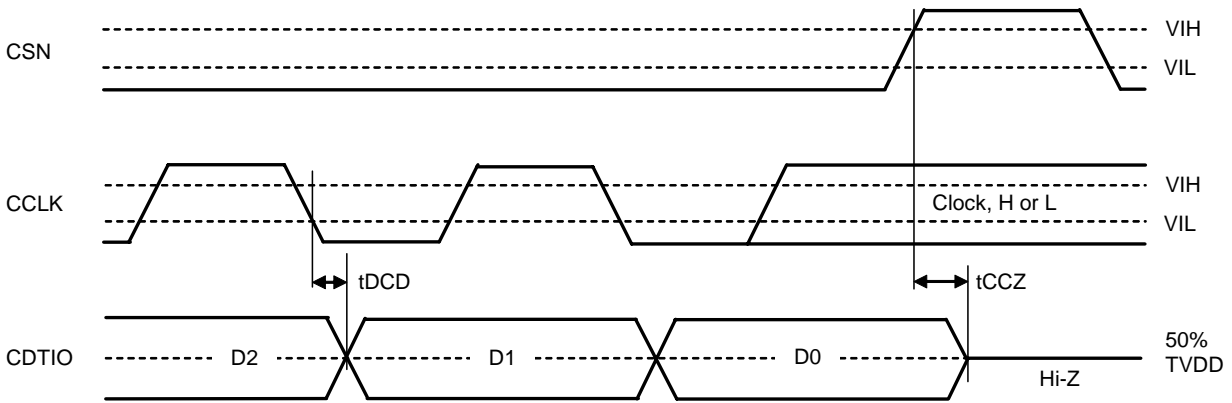

Figure 11. Read Data Output Timing

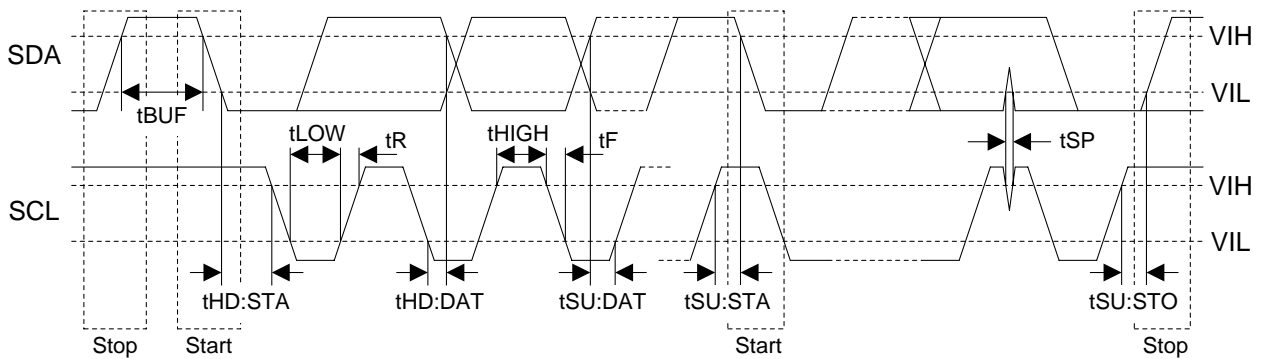

Figure 12. I²C Bus Mode Timing

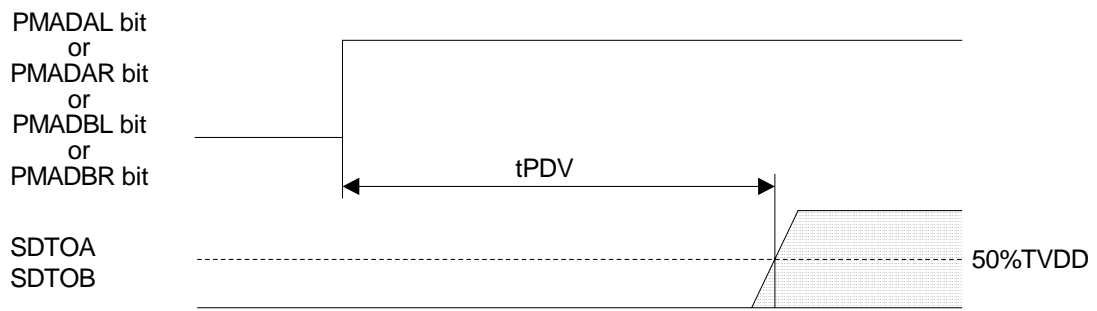

Figure 13. Power Down & Reset Timing 1

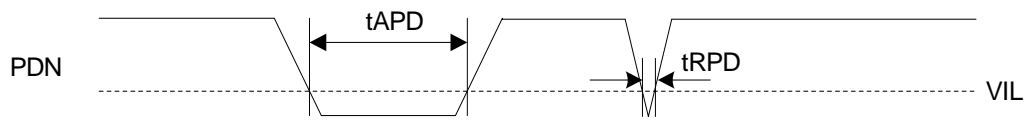

Figure 14. Power Down & Reset Timing 2

OPERATION OVERVIEW

■ System Clock

There are the following five clock modes to interface with external devices (Table 1, Table 2).

Mode	PMPLL bit	M/S bit	PLL3-0 bits	Figure
PLL Master Mode (Note 25)	1	1	Table 4	Figure 15
PLL Slave Mode 1 (PLL Reference Clock: MCKI pin)	1	0	Table 4	Figure 16
PLL Slave Mode 2 (PLL Reference Clock: BICK pin)	1	0	Table 4	Figure 17
EXT Slave Mode	0	0	x	Figure 18
EXT Master Mode	0	1	x	Figure 19

Note 25. If M/S bit = "1", PMPLL bit = "0" and MCKO bit = "1" during the setting of PLL Master Mode, the invalid clocks are output from the MCKO pin.

Table 1. Clock Mode Setting (x: Don't care)

Mode	MCKO bit	MCKO pin	MCKI pin	BICK pin	LRCK pin
PLL Master Mode	0	"L"	Selected by PLL3-0 bits	Output (Selected by BCKO1-0 bits)	Output (1fs)
	1	Selected by PS1-0 bits			
PLL Slave Mode 1 (PLL Reference Clock: MCKI pin)	0	"L"	Selected by PLL3-0 bits	Input (≥ 32fs)	Input (1fs)
	1	Selected by PS1-0 bits			
PLL Slave Mode 2 (PLL Reference Clock: BICK pin)	0	"L"	GND	Input (Selected by PLL3-0 bits)	Input (1fs)
	1	Selected by PS1-0 bits			
EXT Slave Mode	0	"L"	Selected by CM1-0 bits	Input (≥ 32fs)	Input (1fs)
	1	N/A			
EXT Master Mode	0	"L"	Selected by CM1-0 bits	Output (Selected by BCKO1-0 bits)	Output (1fs)
	1	N/A			

Table 2. Clock pins state in Clock Mode (N/A: Not Available)

■ Master Mode/Slave Mode

The M/S bit selects either master or slave mode. M/S bit = "1" selects master mode and "0" selects slave mode. When the AK5703 is in power-down mode (PDN pin = "L") and when exits reset state, the AK5703 is in slave mode. After exiting reset state, the AK5703 goes to master mode by changing M/S bit = "1".

When the AK5703 is in master mode, the LRCK and BICK pins are a Hi-Z state until M/S bit becomes "1". The LRCK and BICK pins of the AK5703 must be pulled-down or pulled-up by a resistor (about 100kΩ) externally to avoid the floating state.

M/S bit	Mode
0	Slave Mode
1	Master Mode

(default)

Table 3. Select Master/Slave Mode

■ PLL Mode

When PMPLL bit is “1”, a fully integrated analog phase locked loop (PLL) circuit generates a clock that is selected by the PLL2-0 and FS3-0 bits. The PLL lock times, when the AK5703 is supplied stable clocks or the sampling frequency is changed after PLL is powered-up (PMPLL bit = “0” → “1”), are shown in [Table 4](#).

1) PLL Mode Setting

Mode	PLL3 bit	PLL2 bit	PLL1 bit	PLL0 bit	PLL Reference Clock Input Pin	Input Frequency	PLL Lock Time (max)
1	0	0	0	1	BICK pin	128fs	2ms
2	0	0	1	0	BICK pin	32fs	2ms
3	0	0	1	1	BICK pin	64fs	2ms
4	0	1	0	0	MCKI pin	11.2896MHz	10ms
5	0	1	0	1	MCKI pin	12.288MHz	10ms
6	0	1	1	0	MCKI pin	12MHz	10ms
7	0	1	1	1	MCKI pin	24MHz	10ms
8	1	0	0	0	MCKI pin	19.2MHz	10ms
10	1	0	1	0	MCKI pin	13MHz	10ms
11	1	0	1	1	MCKI pin	26MHz	10ms
12	1	1	0	0	MCKI pin	13.5MHz	10ms
13	1	1	0	1	MCKI pin	27MHz	10ms
Others	Others			N/A			

Table 4. Setting of PLL Mode (fs: Sampling Frequency), (N/A: Not Available)

2) Setting of sampling frequency in PLL Mode

When the PLL reference clock input is the MCKI pin or the BICK pin, the sampling frequency is selected by FS3-0 bits as defined in [Table 5](#).

Mode	FS3 bit	FS2 bit	FS1 bit	FS0 bit	Sampling Frequency (Note 26)
0	0	0	0	0	8kHz mode
1	0	0	0	1	12kHz mode
2	0	0	1	0	16kHz mode
3	0	0	1	1	24kHz mode
5	0	1	0	1	11.025kHz mode
7	0	1	1	1	22.05kHz mode
10	1	0	1	0	32kHz mode
11	1	0	1	1	48kHz mode
15	1	1	1	1	44.1kHz mode
Others	Others				N/A

Table 5. Setting of Sampling Frequency at PMPLL bit = “1” (N/A: Not Available)

Note 26. When the MCKI pin is the PLL reference clock input, the sampling frequency generated by PLL differs from the sampling frequency of mode name in some combinations of MCKI frequency(PLL3-0 bits) and sampling frequency (FS3-0 bits). Refer to [Table 6](#) for the details of sampling frequency. In master mode, LRCK and BICK output frequency correspond to sampling frequencies shown in [Table 6](#). When the BICK pin is the PLL reference clock input, the sampling frequency generated by PLL is the same sampling frequency of mode name.

Input Frequency MCKI[MHz]	Sampling Frequency Mode	Sampling Frequency generated by PLL [kHz](Note 27)
11.2896	8kHz mode	8.000000
	12kHz mode	12.000000
	16kHz mode	16.000000
	24kHz mode	24.000000
	32kHz mode	32.000000
	48kHz mode	48.000000
	11.025kHz mode	11.025000
	22.05kHz mode	22.050000
12.288	8kHz mode	8.000000
	12kHz mode	12.000000
	16kHz mode	16.000000
	24kHz mode	24.000000
	32kHz mode	32.000000
	48kHz mode	48.000000
	11.025kHz mode	11.025000
	22.05kHz mode	22.050000
12	8kHz mode	8.000000
	12kHz mode	12.000000
	16kHz mode	16.000000
	24kHz mode	24.000000
	32kHz mode	32.000000
	48kHz mode	48.000000
	11.025kHz mode	11.024877
	22.05kHz mode	22.049753
24	8kHz mode	8.000000
	12kHz mode	12.000000
	16kHz mode	16.000000
	24kHz mode	24.000000
	32kHz mode	32.000000
	48kHz mode	48.000000
	11.025kHz mode	11.024877
	22.05kHz mode	22.049753
	44.1kHz mode	44.099507
	Sampling frequency that differs from sampling frequency of mode name	

Note 27. These are rounded off to six decimal places.

Table 6. Sampling Frequency at PLL mode (Reference clock is MCKI)

Input Frequency MCKI[MHz]	Sampling Frequency Mode	Sampling Frequency generated by PLL [kHz](Note 27)
19.2	8kHz mode	8.000000
	12kHz mode	12.000000
	16kHz mode	16.000000
	24kHz mode	24.000000
	32kHz mode	32.000000
	48kHz mode	48.000000
	11.025kHz mode	11.025000
	22.05kHz mode	22.050000
44.1kHz mode	44.100000	
13	8kHz mode	7.999786
	12kHz mode	11.999679
	16kHz mode	15.999572
	24kHz mode	23.999358
	32kHz mode	31.999144
	48kHz mode	47.998716
	11.025kHz mode	11.024877
	22.05kHz mode	22.049753
44.1kHz mode	44.099507	
26	8kHz mode	7.999786
	12kHz mode	11.999679
	16kHz mode	15.999572
	24kHz mode	23.999358
	32kHz mode	31.999144
	48kHz mode	47.998716
	11.025kHz mode	11.024877
	22.05kHz mode	22.049753
44.1kHz mode	44.099507	
13.5	8kHz mode	8.000300
	12kHz mode	12.000451
	16kHz mode	16.000601
	24kHz mode	24.000901
	32kHz mode	32.001202
	48kHz mode	48.001803
	11.025kHz mode	11.025218
	22.05kHz mode	22.050436
44.1kHz mode	44.100871	
27	8kHz mode	8.000300
	12kHz mode	12.000451
	16kHz mode	16.000601
	24kHz mode	24.000901
	32kHz mode	32.001202
	48kHz mode	48.001803
	11.025kHz mode	11.025218
	22.05kHz mode	22.050436
44.1kHz mode	44.100871	
	Sampling frequency that differs from sampling frequency of mode name	

Note 27. These are rounded off to six decimal places.

Table 6. Sampling Frequency at PLL mode (Reference clock is MCKI)

■PLL Unlock State

1) PLL Master Mode (PMPLL bit = "1", M/S bit = "1")

In this mode, the LRCK and BICK pin go to "L", and an irregular frequency clock is output from the MCKO pin when MCKO bit is "1" before the PLL goes to lock state after PMPLL bit = "0" → "1". If MCKO bit is "0", the MCKO pin outputs "L" (Table 7).

After the PLL is locked, a first period of LRCK and BICK may be invalid clock, but these clocks return to normal state after a period of 1/fs.

When sampling frequency is changed, BICK and LRCK pins do not output irregular frequency clocks but go to "L" by setting PMPLL bit "0".

PLL State	MCKO pin		BICK pin	LRCK pin
	MCKO bit = "0"	MCKO bit = "1"		
After that PMPLL bit "0" → "1"	"L" Output	Invalid	"L" Output	"L" Output
PLL Unlock (except above case)	"L" Output	Invalid	Invalid	Invalid
PLL Lock	"L" Output	Table 9	Table 10	1fs Output

Table 7. Clock Operation at PLL Master Mode (PMPLL bit = "1", M/S bit = "1")

2) PLL Slave Mode (PMPLL bit = "1", M/S bit = "0")

In this mode, an invalid clock is output from the MCKO pin before the PLL goes to lock state after PMPLL bit = "0" → "1". Then, the clock selected by Table 9 is output from the MCKO pin when PLL is locked. ADC output invalid data when the PLL is unlocked.

PLL State	MCKO pin	
	MCKO bit = "0"	MCKO bit = "1"
After that PMPLL bit "0" → "1"	"L" Output	Invalid
PLL Unlock (except above case)	"L" Output	Invalid
PLL Lock	"L" Output	Table 9

Table 8. Clock Operation at PLL Slave Mode (PMPLL bit = "1", M/S bit = "0")

■ PLL Master Mode (PMPLL bit = “1”, M/S bit = “1”)

When an external clock (11.2896MHz, 12MHz, 12.288MHz, 13MHz, 13.5MHz, 19.2MHz, 24MHz, 26MHz or 27MHz) is input to the MCKI pin, the internal PLL circuit generates MCKO, BICK and LRCK clocks. The MCKO output frequency is selected by PS1-0 bits (Table 9) and the output is enabled by MCKO bit. The BICK output frequency is selected between 32fs, 64fs or 128fs, by BCKO1-0 bits (Table 10).

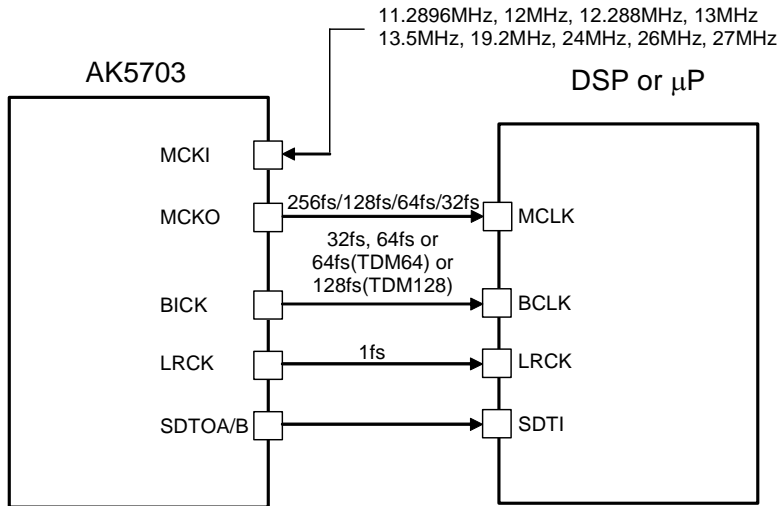

Figure 15. PLL Master Mode

Mode	PS1 bit	PS0 bit	MCKO pin
0	0	0	256fs
1	0	1	128fs
2	1	0	64fs
3	1	1	32fs

(default)

Table 9. MCKO Output Frequency (PLL Mode, MCKO bit = “1”)

Mode	BCKO1 bit	BCKO0 bit	BICK Output Frequency
0	0	0	32fs
1	0	1	64fs
2	1	0	128fs (TDM128 Mode)
3	1	1	N/A

(default)

Note 28. 128fs is only available in TDM mode.

Table 10. BICK Output Frequency at Master Mode (N/A: Not Available)

■ PLL Slave Mode (PMPLL bit = “1”, M/S bit = “0”)

A reference clock of PLL is selected among the input clocks to MCKI or BICK pin. The required clock to the AK5703 is generated by an internal PLL circuit. Input frequency is selected by PLL3-0 bits (Table 4).

a) PLL Slave Mode 1 (PLL reference clock: MCKI pin)

The BICK and LRCK inputs must be synchronized with MCKO output. The phase between MCKO and LRCK is not important. The MCKO pin outputs the frequency selected by PS1-0 bits (Table 9) and the output is enabled by MCKO bit. Sampling frequency can be selected by FS3-0 bits (Table 5).

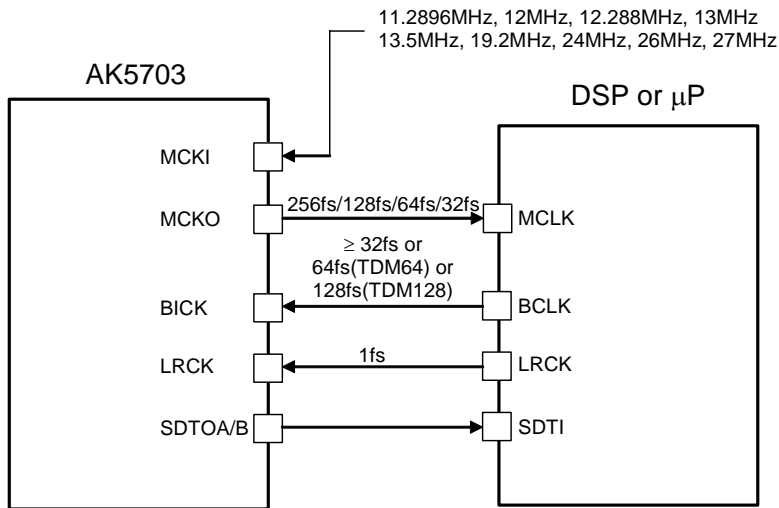

Figure 16. PLL Slave Mode 1 (PLL Reference Clock: MCKI pin)

b) PLL Slave Mode 2 (PLL reference clock: BICK pin)

The sampling frequency corresponds to a range from 8kHz to 48kHz by changing FS3-0 bits (Table 5). The MCKO output frequency is selected by PS1-0 bits (Table 9) and the output is enabled by MCKO bit.

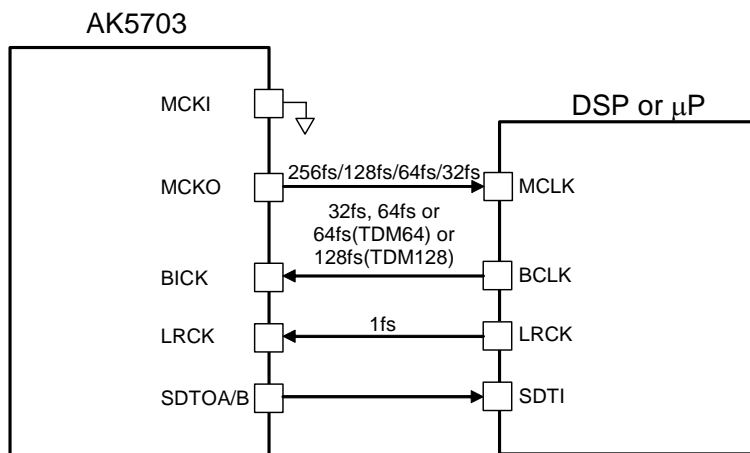

Figure 17. PLL Slave Mode 2 (PLL Reference Clock: BICK pin)

■ EXT Slave Mode (PMPLL bit = “0”, M/S bit = “0”)

When PMPLL bit is “0”, the AK5703 becomes EXT mode. Master clock can be input to the internal ADC directly from the MCKI pin without internal PLL circuit operation. This mode is compatible with I/F of a normal audio CODEC. The clocks required to operate the AK5703 are MCKI (256fs, 512fs or 1024fs), LRCK (fs) and BICK (≥ 32 fs). The master clock (MCKI) must be synchronized with LRCK. The phase between these clocks is not important. The input frequency of MCKI is selected by CM1-0 bits (Table 11) and sampling frequency is selected by FS3-0 bits (Table 12).

Mode	CM1 bit	CM0 bit	MCKI Input Frequency	Sampling Frequency Range
0	0	0	256fs	24kHz ~ 48kHz
1	0	1	512fs	8kHz ~ 24kHz
2	1	0	1024fs	8kHz ~ 12kHz
3	1	1	256fs	8kHz ~ 24kHz

(default)

Table 11. MCKI Frequency at EXT Slave Mode (PMPLL bit = “0”, M/S bit = “0”)

Mode	FS3 bit	FS2 bit	FS1 bit	FS0 bit	Sampling Frequency
0	0	0	0	0	8kHz
1	0	0	0	1	12kHz
2	0	0	1	0	16kHz
3	0	0	1	1	24kHz
5	0	1	0	1	11.025kHz
7	0	1	1	1	22.05kHz
10	1	0	1	0	32kHz
11	1	0	1	1	48kHz
15	1	1	1	1	44.1kHz
Others	Others				N/A

(default)

Table 12. Setting of Sampling Frequency (N/A: Not Available)

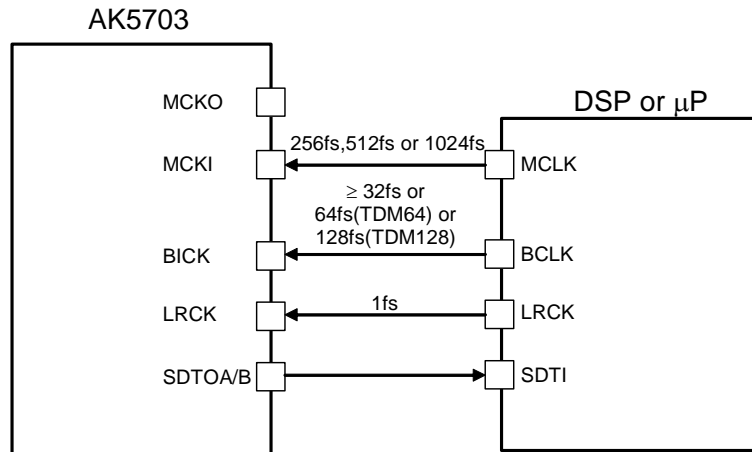

Figure 18. EXT Slave Mode

■ EXT Master Mode (PMPLL bit = “0”, M/S bit = “1”)

The AK5703 becomes EXT Master Mode by setting PMPLL bit = “0” and M/S bit = “1”. Master clock can be input to the internal ADC directly from the MCKI pin without the internal PLL circuit operation. The clock required to operate is MCKI (256fs, 512fs, or 1024fs). The input frequency of MCKI is selected by CM1-0 bits (Table 13) and sampling frequency is selected by FS3-0 bits (Table 14). The BICK output frequency is selected between 32fs, 64fs or 128fs, by BCKO1-0 bits (Table 15).

Mode	CM1 bit	CM0 bit	MCKI Input Frequency	Sampling Frequency Range
0	0	0	256fs	24kHz ~ 48kHz
1	0	1	512fs	8kHz ~ 24kHz
2	1	0	1024fs	8kHz ~ 12kHz
3	1	1	256fs	8kHz ~ 24kHz

(default)

Table 13. MCKI Frequency at EXT Master Mode (PMPLL bit = “0”, M/S bit = “1”)

Mode	FS3 bit	FS2 bit	FS1 bit	FS0 bit	Sampling Frequency
0	0	0	0	0	8kHz
1	0	0	0	1	12kHz
2	0	0	1	0	16kHz
3	0	0	1	1	24kHz
5	0	1	0	1	11.025kHz
7	0	1	1	1	22.05kHz
10	1	0	1	0	32kHz
11	1	0	1	1	48kHz
15	1	1	1	1	44.1kHz
Others	Others				N/A

(default)

Table 14. Setting of Sampling Frequency (N/A: Not Available)

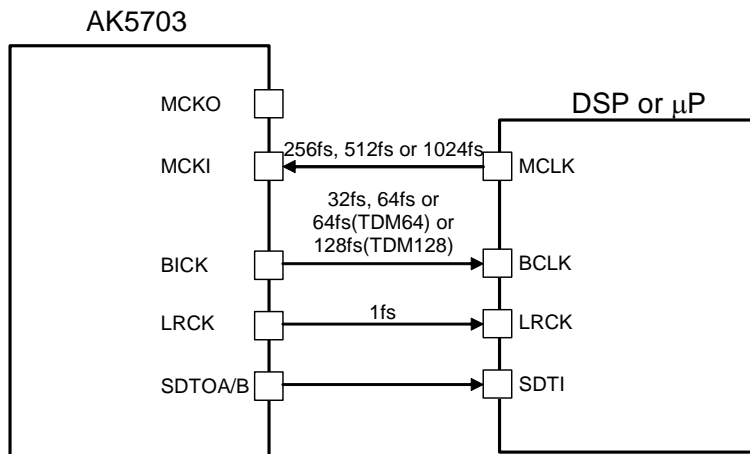

Figure 19. EXT Master Mode

Mode	BCKO1 bit	BCKO0 bit	BICK Output Frequency
0	0	0	32fs
1	0	1	64fs
2	1	0	128fs (TDM128 Mode)
3	1	1	N/A

(default)

Note 28. 128fs is only available in TDM mode.

Table 15. BICK Output Frequency at Master Mode (N/A: Not Available)

■ SYSTEM RESET

Upon power-up, the AK5703 must be reset by bringing the PDN pin = “L”. This reset is released when a dummy command is input after the PDN pin = “H”. This ensures that all internal registers reset to their initial value. Dummy command is executed by writing all “0” to the register address 00H (In fact, after 16 times rising edge of CCLK/SCL.). It is recommended to set the PDN pin = “L” before power up the AK5703.

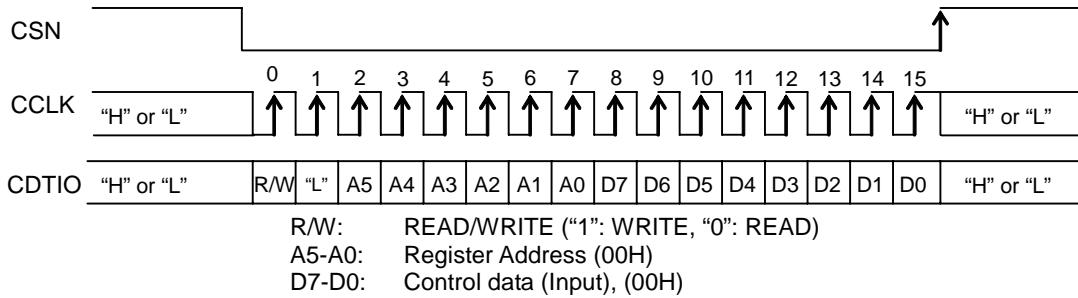

Figure 20. Dummy Command in 3-wired Serial Mode

In I²C mode, the AK5703 does not return an ACK after receiving a slave address by a dummy command as shown in Figure 21. Therefore, the slave address needs to be sent twice if the I²C transmitting stops after the first slave address. In the actual case, initializing cycle starts by 16 SCL clocks during the PDN pin = “H” regardless of the SDA line. Executing a write or read command to the other device that is connected to the same I²C-bus also resets the AK5703.

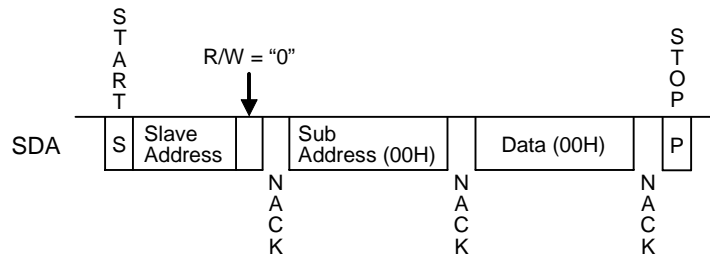

Figure 21. Dummy Command in I²C-bus Mode

The ADCA enters an initialization cycle when the PMADAL or PMADAR bit is changed from “0” to “1” on the condition of PMADAL = PMADAR bits = “0”. The initialization cycle time is set by ADRSTA1-0 bits (Table 16). The ADCB enters an initialization cycle when the PMADBL or PMADBR bit is changed from “0” to “1” on the condition of PMADBL = PMADBR bits = “0”. The initialization cycle time is set by ADRSTB1-0 bits (Table 16). During the initialization cycle, the ADC digital data outputs of both channels are forced to a 2's complement, “0”. The ADC output reflects the analog input signal after the initialization cycle is complete.

Note 29. The initial data of ADC has offset data that depends on the condition of the microphone and the cut-off frequency of HPF. If this offset is not small, make initialization cycle longer by setting ADRSTA/B1-0 bits or do not use the initial data of ADC.

ADRSTA1 bit ADRSTB1 bit	ADRSTA0 bit ADRSTB0 bit	Initialization Cycle			
		Cycle	fs = 44.1kHz	fs = 22.05kHz	fs = 11.025kHz
0	0	1059/fs	24.0ms	48.0ms	96.1ms
0	1	267/fs	6.1ms	12.1ms	24.2ms
1	0	2115/fs	48.0ms	95.9ms	191.8ms
1	1	531/fs	12.0ms	24.1ms	48.2ms

(default)

Table 16. ADC Initialization Cycle

■ Audio Interface Format

Eight types of data formats are available and selected by setting the TDM1-0 and DIF1-0 bits (Table 17, Table 18 and Table 19). In all modes, the serial data is MSB first, 2's complement format. Audio interface formats can be used in both master and slave modes. LRCK and BICK are output from the AK5703 in master mode, but must be input to the AK5703 in slave mode. The SDTO is clocked out on the falling edge ("↓") of BICK.

In TDM64 Mode at master operation, BICK output frequency is set 64fs by BCKO1-0 bits = "01".

In TDM128 Mode at master operation, BICK output frequency is set 128fs by BCKO1-0 bits = "10".

In TDM Mode, SDTOB outputs 4-ch data and SDTOA is fixed "L" output.

Mode	TDM1 bit	TDM0 bit	DIF1 bit	DIF0 bit	SDTOA/B	BICK	Figure
0	0	0	0	0	16bit MSB justified	≥ 32fs	Figure 22
1	0	0	0	1	16bit I ² S compatible	≥ 32fs	Figure 23
2	0	0	1	0	24bit MSB justified	≥ 48fs	Figure 24
3	0	0	1	1	24bit I ² S compatible	≥ 48fs	Figure 25 (default)

Table 17. Audio Interface Format (Stereo Mode) (N/A: Not Available)

Mode	TDM1 bit	TDM0 bit	DIF1 bit	DIF0 bit	SDTOB	BICK	Figure
4	0	1	0	0	N/A	-	-
5	0	1	0	1	N/A	-	-
6	0	1	1	0	16bit MSB justified	64fs	Figure 26
7	0	1	1	1	16bit I ² S compatible	64fs	Figure 27

Table 18. Audio Interface Format (TDM64 Mode) (N/A: Not Available)

Mode	TDM1 bit	TDM0 bit	DIF1 bit	DIF0 bit	SDTOB	BICK	Figure
8	1	1	0	0	N/A	-	-
9	1	1	0	1	N/A	-	-
10	1	1	1	0	24bit MSB justified	128fs	Figure 28
11	1	1	1	1	24bit I ² S compatible	128fs	Figure 29

Table 19. Audio Interface Format (TDM128 Mode) (N/A: Not Available)

If 24 or 16-bit data, the output of ADC, is converted to an 8-bit data by removing LSB 16 or 8-bit, "-1" data is converted to "-1" of 8-bit data. And when the DAC plays back this 8-bit data, "-1" of 8-bit data will be converted to "-65536" or "-256" of 24 or 16-bit data which is a large offset. This offset can be removed by adding the offset of "32768" or "128" to 24 or 16-bit data, respectively before converting to 8-bit data. ADC.

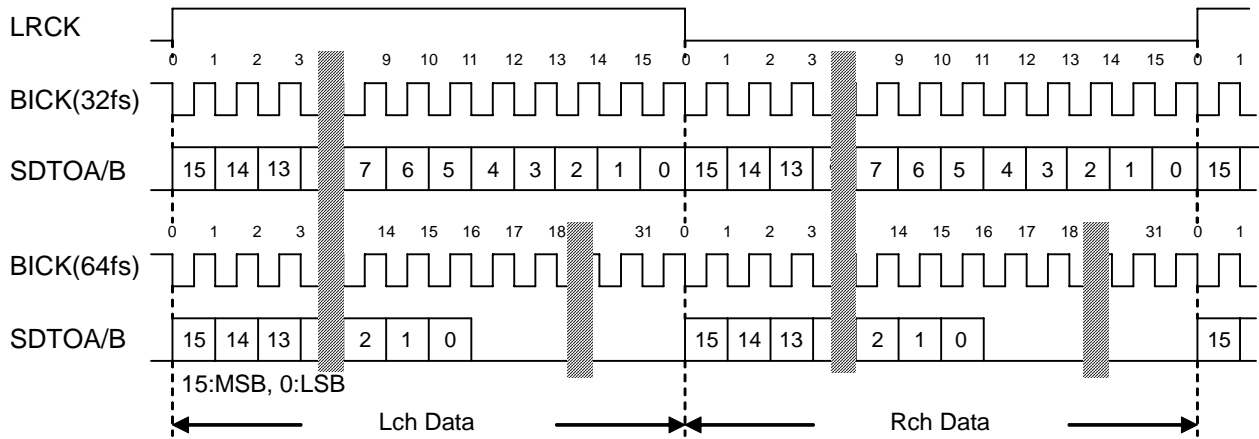

Figure 22. Mode 0 Timing (Stereo Mode, 16bit MSB justified)

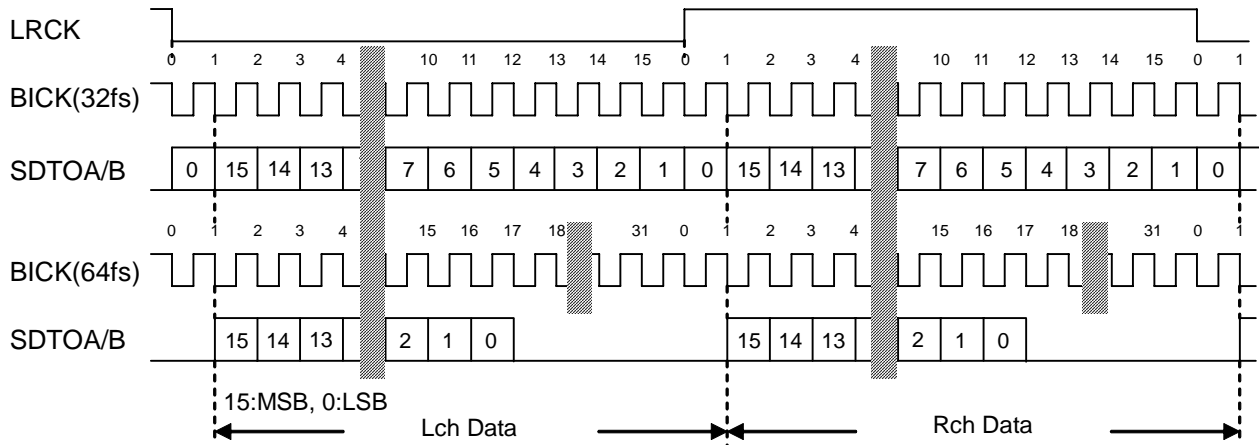

Figure 23. Mode 1 Timing (Stereo Mode, 16bit I²S compatible)

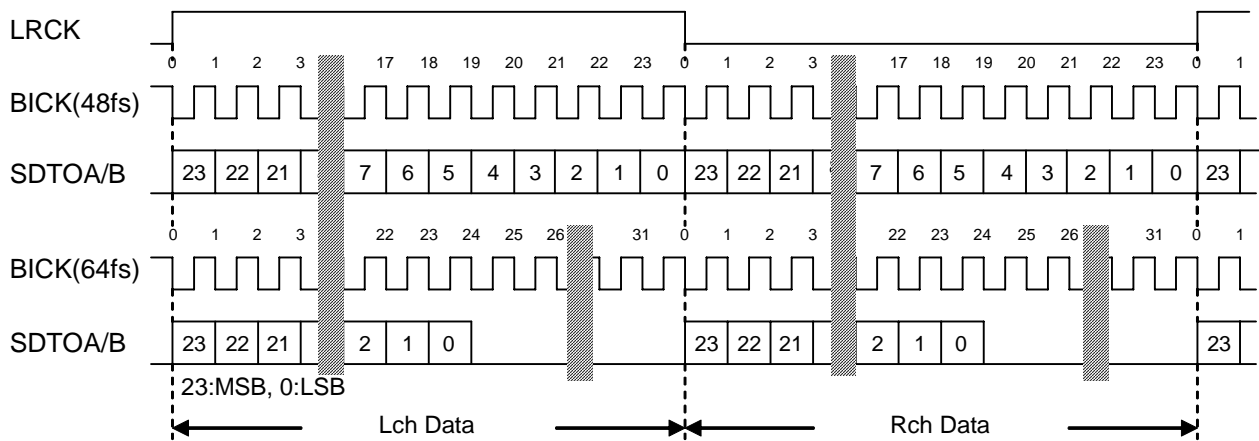

Figure 24. Mode 2 Timing (Stereo Mode, 24bit MSB justified)

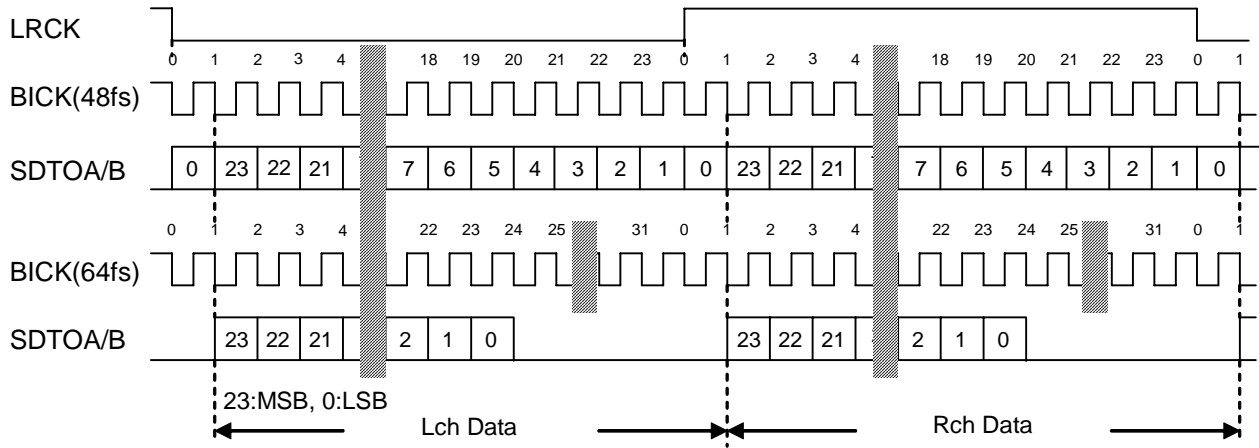

Figure 25. Mode 3 Timing (Stereo Mode, 24bit I²S compatible)

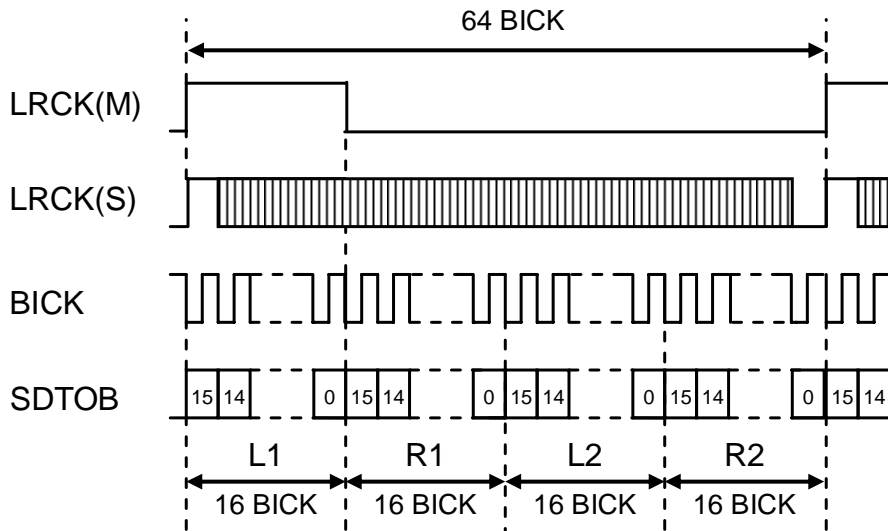

Figure 26. Mode 6 Timing (TDM64 mode, MSB justified)

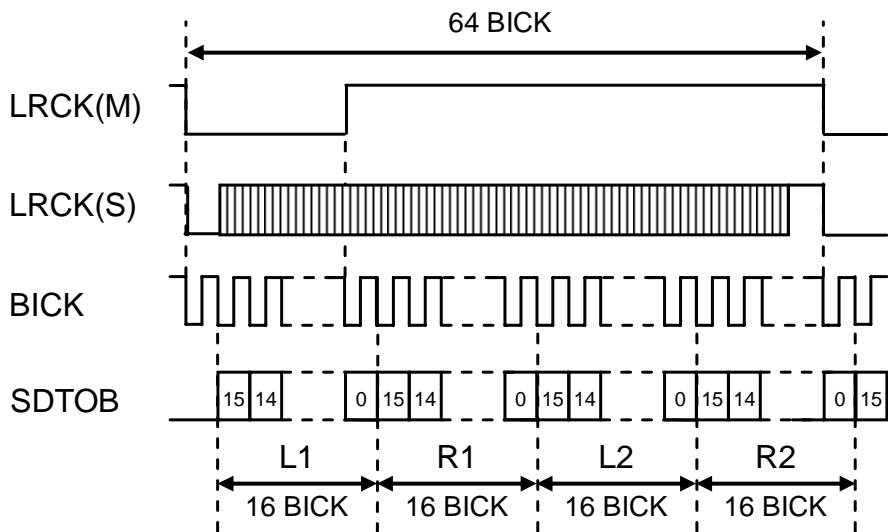

Figure 27. Mode 7 Timing (TDM64 mode, I²S compatible)

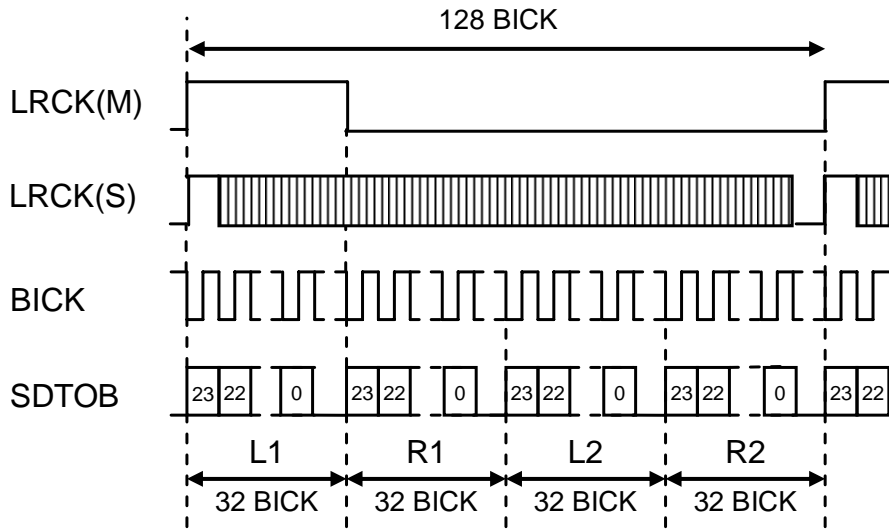

Figure 28. Mode 10 Timing (TDM128 Mode, MSB justified)

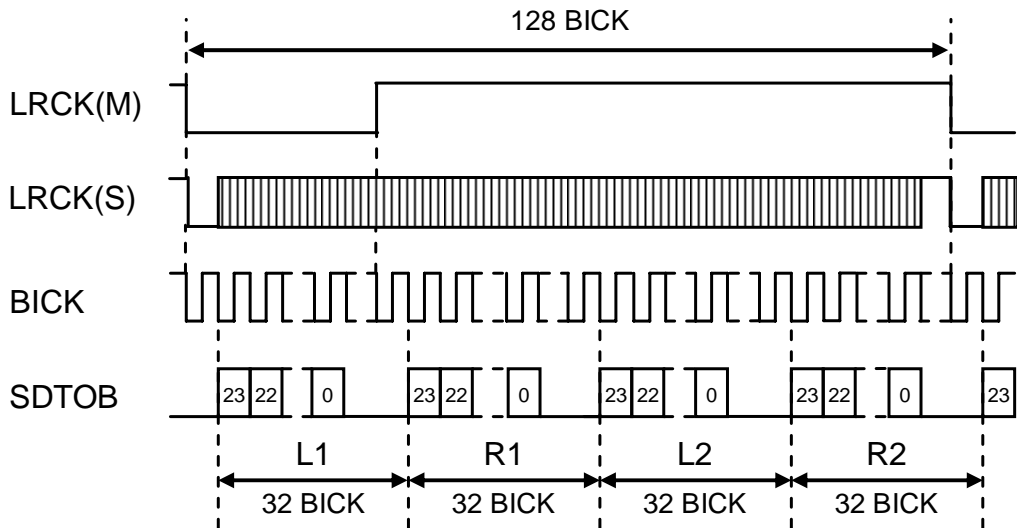

Figure 29. Mode 11 Timing (TDM128 mode, I²S compatible)

■ Microphone/LINE Input

The AK5703 can be selected single-ended or full differential inputs. When MDIFA1, MDIFA2, MDIFB1 and MDIFB2 bits are “0”, LIN1, RIN1, LIN2 and RIN2 pins support single-ended inputs (). When MDIFA1, MDIFA2, MDIFB1 and MDIFB2 bits are “1”, LIN1, RIN1, LIN2 and RIN2 pins become LINA+, RINA+, LINB+ and RINB+ pins, respectively. In this case, full-differential input is available in combination with LINA–, RINA–, LINB– and RINB– pins, respectively (Figure 31).

MDIFA1 bit	MDIFA2 bit	Lch	Rch	
0	0	LIN1	RIN1	(default)
	1	LIN1	RINA+/-	
1	0	LINA+/-	RIN1	
	1	LINA+/-	RINA+/-	

Table 20. ADCA MIC/Line Input Select

MDIFB1 bit	MDIFB2 bit	Lch	Rch	
0	0	LIN2	RIN2	(default)
	1	LIN2	RINB+/-	
1	0	LINB+/-	RIN2	
	1	LINB+/-	RINB+/-	

Table 21. ADCB MIC/Line Input Select

■ Microphone Gain Amplifier

The AK5703 has a gain amplifier for microphone input. The gain of MIC-Amp Lch and Rch is independently selected by the MGAINA2-0 and MGAINB2-0 bits (Table 22). The typical input resistance is 100kΩ.

MGAINA2 bit MGAINB2 bit	MGAINA1 bit MGAINB1 bit	MGAINA0 bit MGAINB0 bit	Input Gain	
0	0	0	0dB	(default)
0	0	1	+8dB	
0	1	0	+12dB	
0	1	1	+15dB	
1	0	0	+18dB	
1	0	1	+24dB	
1	1	0	+30dB	
1	1	1	+36dB	

Table 22. Microphone Input Gain

■ Microphone Power

When PMMPA bit (PMMPB bit) = “1”, the MPWRA pin (MPWRB pin) supplies power for the microphone independently. This output voltage is typically 2.4V (0.8 x AVDD) and the load resistance is minimum 0.5kΩ. In case of using two sets of stereo microphones, the load resistance is minimum 2kΩ for each channel. Any capacitor must not be connected directly to the MPWRA and MPWRB pins (Figure 30, Figure 31).

PMMPA bit PMMPB bit	MPWRA pin MPWRB pin
0	Hi-Z
1	Output

(default)

Table 23. Microphone Power

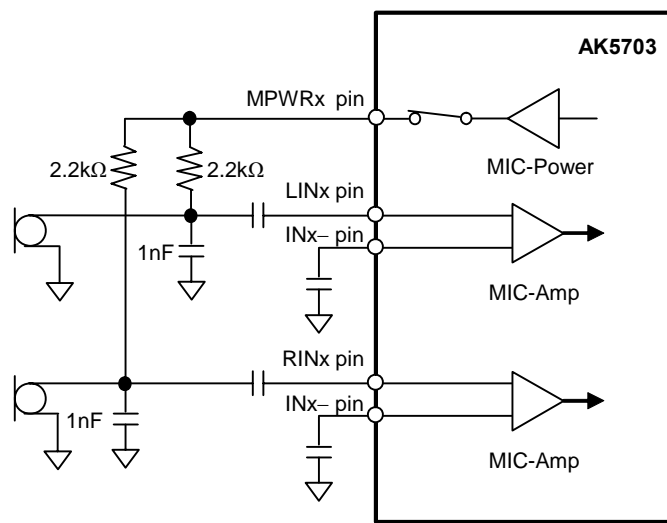

Figure 30. Connection Example for Single-ended Microphone Input

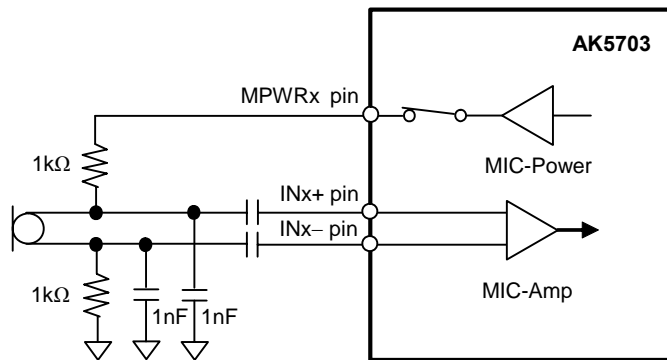

Figure 31. Connection Example for Full-differential Microphone Input (MDIFx1/2 bits = “1”)

■ Programmable Output Data Delay

Output data is independently delayed in state of 64/fs before the Decimation Filter to adjust the phase shift of each 4ch analog inputs into 4ch ADC. Setting resolution of delay amount is 1/64fs and setting range is from 1/64fs to 64/64fs. Delay function of LIN1 channel, RIN1 channel, LIN2 channel and RIN2 channel are independently controlled ON/OFF by DLY1L bit, DLY1R bit, DLY2L bit and DLY2R bits, respectively. When DLYxx bit = “0”, data delay is disable. When DLYxx bit = “1”, data delay is enable.

- DLY1L5-0 bits: Setting the amount of delay for LIN1 channel.
- DLY1R5-0 bits: Setting the amount of delay for RIN1 channel.
- DLY2L5-0 bits: Setting the amount of delay for LIN2 channel.
- DLY2R5-0 bits: Setting the amount of delay for RIN2 channel.

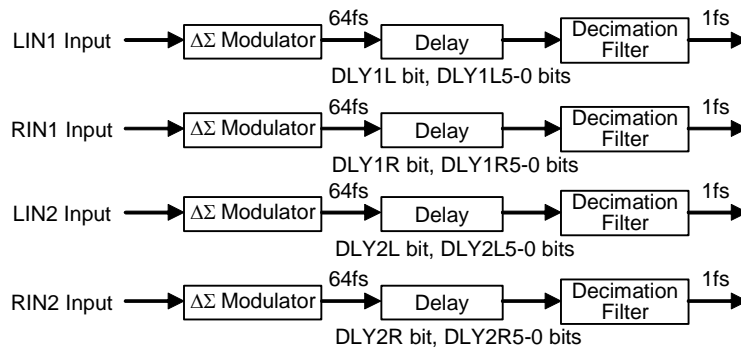

Figure 32. Programmable Output Data Delay

DLY1L5-0 bits DLY1R5-0 bits DLY2L5-0 bits DLY2R5-0 bits	Delay
3FH	64/64fs
3EH	63/64fs
3DH	62/64fs
⋮	⋮
02H	3/64fs
01H	2/64fs
00H	1/64fs (default)

Table 24. Programmable Output Data Delay setting

■ Digital Block

The digital block consists of the blocks shown in [Figure 33](#). When HPFADA/B = HPF2A/B = LPFA/B bits = “1”, HPF1A/B, HPF2A/B and LPFA/B are available. When HPF2A/B = LPFA/B bits = “0”, ADCA/B data bypass the HPF2A/B and LPFA/B and is input to ALCA/B.

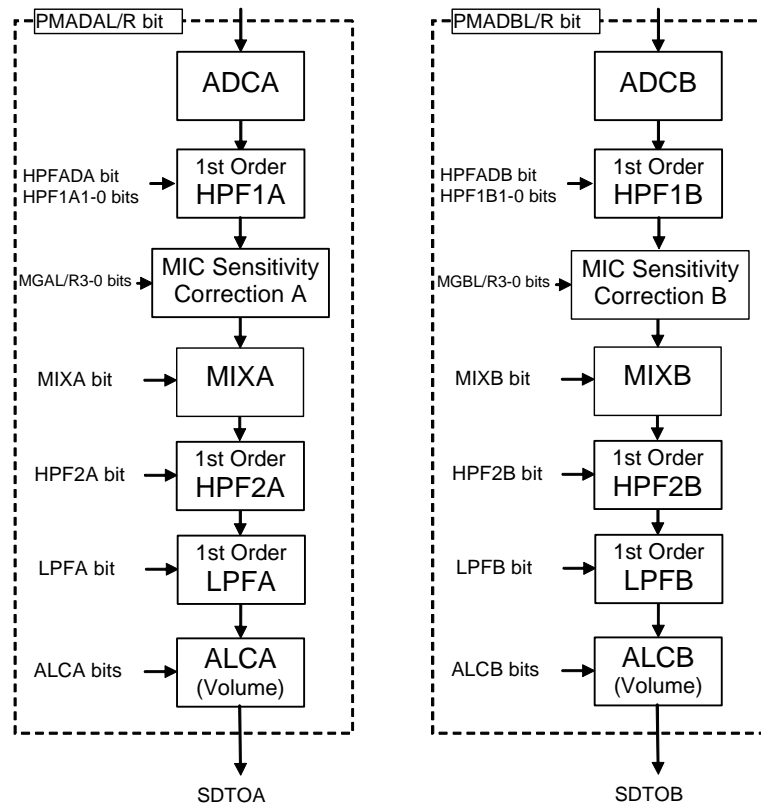

- (1) ADCA/B: Includes the Digital Filter (LPF) for ADC as shown in “[FILTER CHARACTERISTICS](#)” and the Programmable Output Data Delay as shown in “[Programmable Output Data Delay](#)”.
- (2) HPF1A/B: Includes the Digital Filter (HPF) for ADC as shown in “[Digital HPF1A/B](#)”.
- (3) Microphone Sensitivity Correction A/B:
Includes the Microphone Sensitivity Correction as shown in “[Microphone Sensitivity Correction](#)”.
- (4) MIXA/B: Mono/Stereo Mode (See “[Mono/Stereo Mode \(MIXA/B\)](#)”)
- (5) HPF2A/B: High Pass Filter (See “[High Pass Filter \(HPF2A/B\)](#)”)
- (6) LPFA/B: Low Pass Filter (See “[Low Pass Filter \(LPFA/B\)](#)”)
- (7) ALCA/B(Volume): Digital Volume with ALC Function (See “[Input Digital Volume \(Manual Mode\)](#)” and “[ALC Operation](#)”)

Figure 33. Digital Block Path Select

■ Digital HPF1A/B

A digital High Pass Filter (HPF) is integrated for DC offset cancellation of the ADC input. When HPFADA/B bits = “1”, HPF1A/B are available (while using ADC, HPFADA/B bit should be set to “1”). The cut-off frequencies of the HPF1A (HPF1B) are set by HPF1A1-0 (HPF1B1-0) bits (Table 25). It is proportional to the sampling frequency (f_s) and default is 3.4Hz (@ $f_s = 44.1\text{kHz}$).

HPF1A1 bit HPF1B1 bit	HPF1A0 bit HPF1B0 bit	f_c		
		$f_s=44.1\text{kHz}$	$f_s=22.05\text{kHz}$	$f_s=11.025\text{kHz}$
0	0	3.4Hz	1.7Hz	0.85Hz
0	1	6.8Hz	3.4Hz	1.7Hz
1	0	13.6Hz	6.8Hz	3.4Hz
1	1	219.3Hz	109.7Hz	54.8Hz

(default)

Table 25. HPF1A/B Cut-off Frequency

■ Microphone Sensitivity Correction

The AK5703 has microphone sensitivity correction function controlled by MGxx3-0 bits. ADCA Lch gain is controlled by MGAL3-0 bits, ADCA Rch gain is controlled by MGAR3-0 bits, ADCB Lch gain is controlled by MGBL3-0 bits and ADCB Rch gain is controlled by MGBR3-0 bits (Table 26).

MGAL3-0 bits MGAR3-0 bits MGBL3-0 bits MGBR3-0 bits	GAIN (dB)	Step
1000	+3	0.75 (default)
0111	+2.25	
0110	+1.5	
0101	+0.75	
0100	0	
0011	-0.75	
0010	-1.5	
0001	-2.25	
0000	-3	
Others	N/A	

Table 26. Microphone Sensitivity Correction (N/A: Not available)

■ Mono/Stereo Mode (MIXA/B)

PMADAL, PMADAR and MIXA bits select mono or stereo mode of ADCA output data. PMADBL, PMADBR and MIXB bits select mono or stereo mode of ADCB output data. ALC operation (ALCA/B or ALC4 bit = "1") or digital volume operation (ALCA/B = ALC4 bits = "0") is applied to the data in [Table 27](#) and [Table 28](#).

PMADAL bit	PMADAR bit	MIXA bit	ADCA Lch data	ADCA Rch data	(default)
0	0	x	All "0"	All "0"	
0	1	x	Rch Input Signal	Rch Input Signal	
1	0	x	Lch Input Signal	Lch Input Signal	
1	1	0	Lch Input Signal	Rch Input Signal	
		1	(L+R)/2	(L+R)/2	

Table 27. ADCA Mono/Stereo Mode (x: Don't care)

PMADBL bit	PMADBR bit	MIXB bit	ADCB Lch data	ADCB Rch data	(default)
0	0	x	All "0"	All "0"	
0	1	x	Rch Input Signal	Rch Input Signal	
1	0	x	Lch Input Signal	Lch Input Signal	
1	1	0	Lch Input Signal	Rch Input Signal	
		1	(L+R)/2	(L+R)/2	

Table 28. ADCB Mono/Stereo Mode (x: Don't care)

■ High Pass Filter (HPF2A/B)

This is composed 1st order HPF. The coefficient of HPF2A is set by FA1A13-0 bits and FA1B13-0 bits. The coefficient of HPF2B is set by FB1A13-0 bits and FB1B13-0 bits. HPF2A bit controls ON/OFF of the HPF2A and HPF2B bit controls ON/OFF of the HPF2B. When the HPF2A/B is OFF, the audio data passes this block by 0dB gain. The coefficient must be set when HPFA = HPF2B bits = "0". The HPF2A/B starts operation $4/fs(\max)$ after when HPF2A bit = "1" (HPF2B bit = "1") is set.

fs: Sampling frequency

fc: Cut-off frequency

Register setting ([Note 30](#))

HPF: Fx1A[13:0] bits =A, Fx1B[13:0] bits =B
(MSB=Fx1A13, Fx1B13; LSB=Fx1A0, Fx1B0)

$$A = \frac{1 / \tan(\pi fc/fs)}{1 + 1 / \tan(\pi fc/fs)}, \quad B = \frac{1 - 1 / \tan(\pi fc/fs)}{1 + 1 / \tan(\pi fc/fs)}$$

Transfer function

$$H(z) = A \frac{1 - z^{-1}}{1 + Bz^{-1}}$$

The cut-off frequency must be set as below.

$$fc/fs \geq 0.0001 \quad (fc \text{ min} = 4.41\text{Hz at } 44.1\text{kHz})$$

■ Low Pass Filter (LPFA/B)

This is composed with 1st order LPF. FA2A13-0 bits and FA2B13-0 bits set the coefficient of LPFA. FB2A13-0 bits and FB2B13-0 bits set the coefficient of LPFB. LPFA bit controls ON/OFF of the LPFA and LPFB bit controls ON/OFF of the LPFB. When the LPFA/B is OFF, the audio data passes this block by 0dB gain. The coefficient must be set when LPFA = LPFB bits = "0". The LPFA/B starts operation $4/f_s(\max)$ after when LPFA bit = "1" (LPFB bit = "1") is set.

f_s : Sampling frequency

f_c : Cut-off frequency

Register setting (Note 30)

LPF: Fx2A[13:0] bits =A, Fx2B[13:0] bits =B
(MSB=Fx2A13, Fx2B13; LSB=Fx2A0, Fx2B0)

$$A = \frac{1}{1 + 1 / \tan(\pi f_c / f_s)}, \quad B = \frac{1 - 1 / \tan(\pi f_c / f_s)}{1 + 1 / \tan(\pi f_c / f_s)}$$

Transfer function

$$H(z) = A \frac{1 + z^{-1}}{1 + Bz^{-1}}$$

The cut-off frequency must be set as below.

$$f_c / f_s \geq 0.05 \quad (f_c \text{ min} = 2205\text{Hz at } 44.1\text{kHz})$$

Note 30. [Translation the filter coefficient calculated by the equations above from real number to binary code (2's complement)]

$$X = (\text{Real number of filter coefficient calculated by the equations above}) \times 2^{13}$$

X must be rounded to integer, and then should be translated to binary code (2's complement).

MSB of each filter coefficient setting register is sign bit.

■ ALC Operation

The ALC (Automatic Level Control) is operated by ALCA (2ch) block when ALCA bit is “1” and operated by ALCB (2ch) block when ALCB bit is “1”. In this case, both Lch and Rch VOL values are changed together. When ALC4 bit = “0” and ALCA = ALCB bits = “1”, ALC of ADCA and ADCB are independently operated. When ALC4 bit = “1” regardless of ALCA and ALCB bits, ALC is operated for all 4ch of the ADCA and ADCB. In this case, the VOL value is always changed in common with all channels. 4ch Link ALC is operated by the register setting of ADCA (LMTHA1-0, RGAINA2-0, REFA7-0 and RFSTA1-0 bits). In this case, ALC setting of ADCB (LMTHB1-0, RGAINB2-0, REFB7-0 and RFSTB1-0 bits) is invalid.

The ALC block consists of these blocks shown below. ALC limiter detection level and ALC recovery wait counter reset level are monitored at Level Detection 2 block after EQ block. The Level Detection 1 block also monitors clipping detection level (+0.53dBFS).

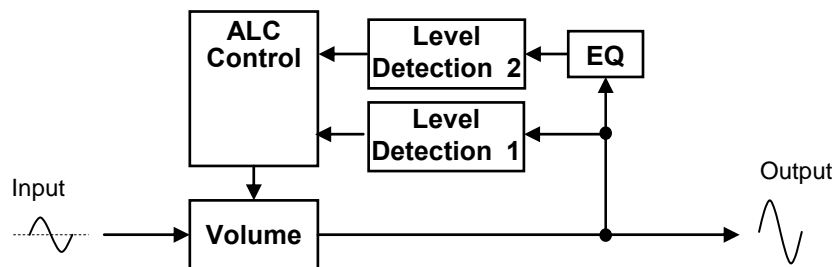

Figure 34. ALC Block

The polar (fc_1) and zero-point (fc_2) frequencies of EQ block are dependent on the sampling frequency. The coefficient is changed automatically according to the sampling frequency range setting. When ALC EQ block is OFF (ALCEQ bit = “1”), these level detection are off.

Sampling Frequency Range	Polar Frequency (fc_1)	Zero-point Frequency (fc_2)	
8kHz ≤ f_s ≤ 12kHz (FS1 bit = “0”)	150Hz	100Hz	$f_s=11.025kHz$
12kHz < f_s ≤ 24kHz (FS3 bit = “0”, FS1 bit = “1”)	150Hz	100Hz	$f_s=22.05kHz$
24kHz < f_s ≤ 48kHz (FS3 bit = “1”, FS1 bit = “1”)	150Hz	100Hz	$f_s=44.1kHz$

Table 29. ALCEQ Frequency Setting

f_s : Sampling Frequency
 fc_1 : Polar Frequency
 fc_2 : Zero-point Frequency

$$A = 10^{K/20} \times \frac{1 + 1 / \tan(\pi fc_2 / f_s)}{1 + 1 / \tan(\pi fc_1 / f_s)}, \quad B = \frac{1 - 1 / \tan(\pi fc_1 / f_s)}{1 + 1 / \tan(\pi fc_1 / f_s)}, \quad C = 10^{K/20} \times \frac{1 - 1 / \tan(\pi fc_2 / f_s)}{1 + 1 / \tan(\pi fc_1 / f_s)}$$

Transfer function

$$H(z) = \frac{A + Cz^{-1}}{1 + Bz^{-1}}$$

[ALCEQ: First order zero pole high pass filter]

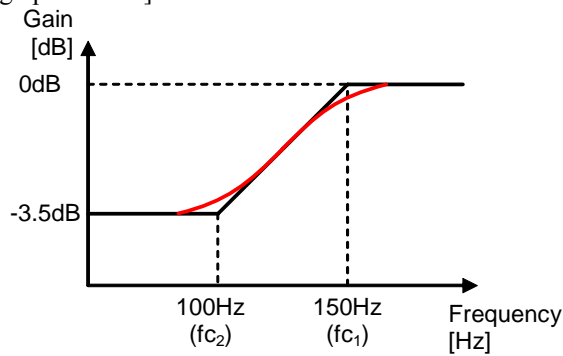

Note 31. Black: Diagrammatic Line, Red: Actual Curve
Figure 35. Frequency Response (fs = 44.1kHz)

1. ALC Limiter Operation

During 2ch Link ALC limiter operation, when either L or R channel output level exceeds the ALC limiter detection level (Table 31), the VOL value (same value for both L and R) is attenuated automatically according to the output level (Table 32). The volume is attenuated by the step amount shown in Table 32 at every sampling. During 4ch Link ALC limiter operation, when either L or R channel output level of ADCA or ADCB exceeds the ALC limiter detection level (Table 31), the VOL value (same value for both L and R) is attenuated automatically according to the output level (Table 32). The volume is attenuated by the step amount shown in Table 32 at every sampling. This attenuation is repeated for sixteen times once ALC limiter operation is executed.

After completing the attenuate operation, unless ALC operation is changed to manual mode, the operation repeats when the input signal level exceeds ALC limiter detection level.

Mode	ALC4 bit	ALCB bit	ALCA bit	ALCB Operation	ALCA Operation
0	0	0	0	Manual	Manual
1	0	0	1	Manual	2ch Link
2	0	1	0	2ch Link	Manual
3	0	1	1	2ch Link	2ch Link
4	1	x	x	4ch Link	

(default)

Note 32. ALC4 bit must be set when ALCA = ALCB bits = “0” or PMADAL = PMADAR = PMADBL = PMADBR bits = “0”. When ALC4 bit = “1”, only either ADCA or ADCB must not be power down.

Table 30. ALC Mode

LMTHA/B1 bits	LMTHA/B0 bits	ALC Limiter Detection Level (LM-LEVEL)	ALC Recovery Waiting Counter Reset Level
0	0	ALC Output $\geq -2.5\text{dBFS}$	$-2.5\text{dBFS} > \text{ALC Output} \geq -4.1\text{dBFS}$
0	1	ALC Output $\geq -4.1\text{dBFS}$	$-4.1\text{dBFS} > \text{ALC Output} \geq -6.0\text{dBFS}$
1	0	ALC Output $\geq -6.0\text{dBFS}$	$-6.0\text{dBFS} > \text{ALC Output} \geq -8.5\text{dBFS}$
1	1	ALC Output $\geq -8.5\text{dBFS}$	$-8.5\text{dBFS} > \text{ALC Output} \geq -12\text{dBFS}$

(default)

Table 31. ALC Limiter Detection Level / Recovery Counter Reset Level

Output Level	ATT Step [dB]
$+0.53\text{dBFS} \leq \text{Output Level (Level Detection 1)}$	0.38148
$-1.16\text{dBFS} \leq \text{EQ Output Level (Level Detection 2)} < +0.53\text{dBFS}$	0.06812
$\text{LM-LEVEL} \leq \text{EQ Output Level (Level Detection 2)} < -1.16\text{dBFS}$	0.02548

Table 32. ALC Limiter ATT Amount

2. ALC Recovery Operation

ALC recovery operation waits for the time set by WTM1-0 bits (Table 33) after completing ALC limiter operation. If the input signal does not exceed “ALC recovery waiting counter reset level” (Table 31) during the wait time, ALC recovery operation is executed. The VOL value is automatically incremented by the amount set by RGAINA/B2-0 bits (Table 34) up to the set reference level (Table 35) in every one sampling. When the VOL value exceeds the reference level (REFA/B7-0), the VOL values are not increased.

When

“ALC recovery waiting counter reset level \leq Output Signal $<$ ALC limiter detection level” during the ALC recovery operation, the waiting timer of ALC recovery operation is reset. When

“ALC recovery waiting counter reset level $>$ Output Signal”, the waiting timer of ALC recovery operation starts.

ALC operations correspond to the impulse noise. When the impulse noise is input, the ALC recovery operation becomes faster than a normal recovery operation. When large noise is input to a microphone instantaneously, the quality of small level in the large noise can be improved by this fast recovery operation. The speed of fast recovery operation is set by RFSTA/B1-0 bits (Table 36). The ATT amount for reference volume of fast recovery operation is set by FRATT bit (Table 37).

WTM1 bit	WTM0 bit	Recovery Wait Time
0	0	128/fs
0	1	256/fs
1	0	512/fs
1	1	1024/fs

(default)

Table 33. ALC Recovery Operation Waiting Period

RGAINA/B2 bits	RGAINA/B1 bits	RGAINA/B0 bits	GAIN Step [dB]	GAIN Switching Timing
0	0	0	0.00424	1/fs
0	0	1	0.00212	1/fs
0	1	0	0.00106	1/fs
0	1	1	0.00106	2/fs
1	0	0	0.00106	4/fs
1	0	1	0.00106	8/fs
1	1	0	0.00106	16/fs
1	1	1	0.00106	32/fs

(default)

Table 34. ALC Recovery GAIN Step

REFA/B7-0 bits	GAIN [dB]	Step
F1H	+36.0	0.375 dB (default)
E0H	+35.625	
EFH	+35.25	
:	:	
E1H	+30.0	
:	:	
92H	+0.375	
91H	0.0	
90H	-0.375	
:	:	
06H	-52.125	
05H	-52.5	
04H ~ 00H	MUTE	

Table 35. Reference Level at ALC Recovery Operation

RFSTA/B1-0 bits	Fast Recovery Gain Step [dB]
00	0.0032
01	0.0042
10	0.0064
11	0.0127

Table 36. Fast Recovery Gain Step

FRATT bit	ATT Amount [dB]	ATT Change Timing
0	-0.00106	4/fs
1	-0.00106	16/fs

Table 37. ATT Amount for Reference Volume of Fast Recovery

3. Example of ALC Setting

Table 38 shows the examples of the ALC setting for recording path.

Register Name	Comment	fs=8kHz		fs=44.1kHz	
		Data	Operation	Data	Operation
LMTHA/B1-0	Limiter detection Level	01	-4.1dBFS	01	-4.1dBFS
WTM1-0	Recovery waiting period	01	32ms	11	23.2ms
REFA/B7-0	Maximum gain at recovery operation	E1H	+30dB	E1H	+30dB
IVA/BL7-0, IVA/BR7-0	Gain of IVOL	E1H	+30dB	E1H	+30dB
RGAINA/B2-0	Recovery GAIN	000	0.00424dB	011	0.00106dB (2/fs)
RFSTA/B1-0	Fast Recovery GAIN	11	0.0127dB	00	0.0032dB
ALCEQN	ALC EQ disable	0	Enable	0	Enable
ALCA/B	ALC enable	1	Enable	1	Enable

Table 38. Example of the ALC Setting

4. Example of registers set-up sequence of ALC Operation

The following registers must not be changed during ALC operation. These bits must be changed after ALC operation is finished by ALCA/B = ALC4 bits = "0". The volume is changed by soft transition to each gain of IVOL (IVA/BL7-0, IVA/BR7-0 bits) until manual mode starts after ALCA/B = ALC4 bits are set to "0".

LMTHA/B1-0, WTM1-0, REFA/B7-0, RGAINA/N2-0, RFSTA/B1-0, FRATT and ALCEQN bits

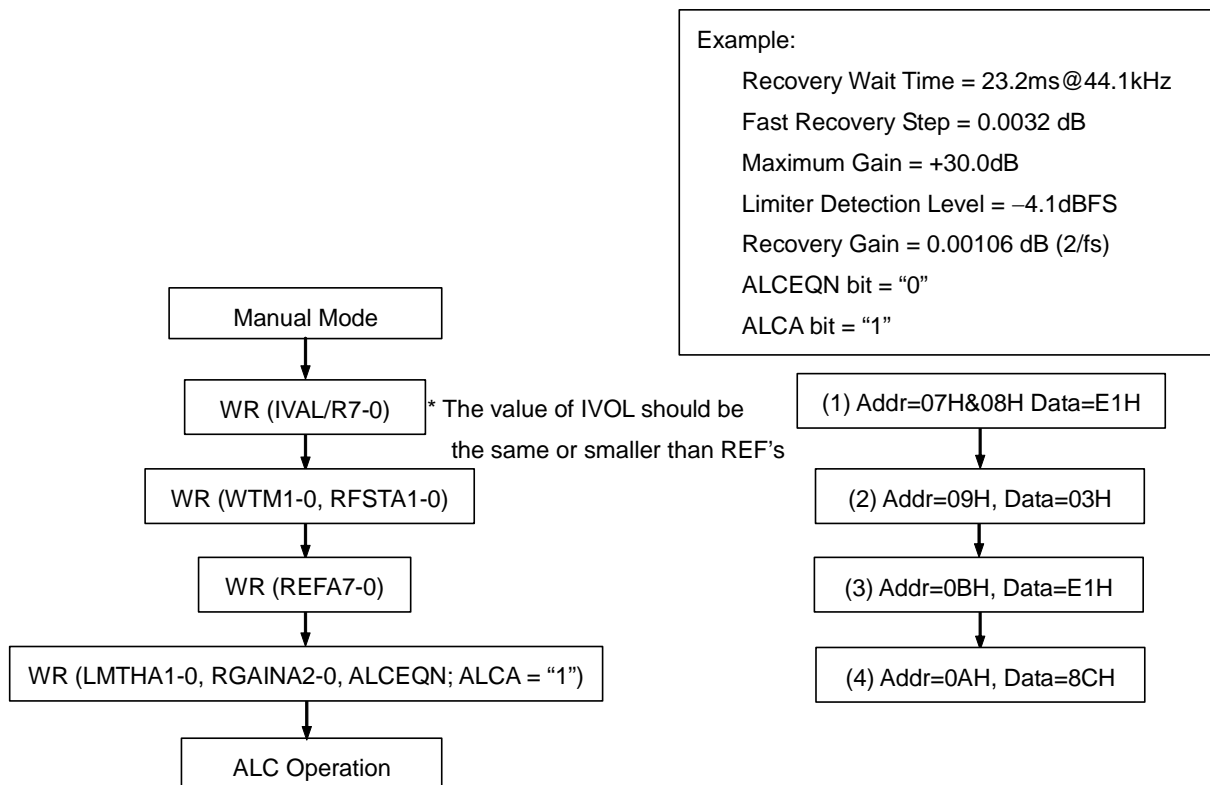

Figure 36. Registers Set-up Sequence in ALC Operation

■ Input Digital Volume (Manual Mode)

The input digital volume becomes manual mode by setting ALCA/B = ALC bits = “0”. This mode is used in the case shown below.

1. After exiting reset state, when setting up the registers for ALC operation (such as LMTHA/B bits and etc.)
2. When the registers for ALC operation (Limiter period, Recovery period and etc.) are changed.
For example; when the sampling frequency is changed.
3. When IVOL is used as a manual volume control.

IVA/BL7-0 and IVA/BR7-0 bits set the gain of the digital input volume (Table 39). ALch and ARch volumes are set individually by IVAL7-0 and IVAR7-0 bits when IVOLAC bit = “0”. IVAL7-0 bits control both ALch and ARch volumes together when IVOLAC bit = “1”. BLch and BRch volumes are set individually by IVBL7-0 and IVBR7-0 bits when IVOLBC bit = “0”. IVBL7-0 bits control both BLch and BRch volumes together when IVOLBC bit = “1”. This volume has a soft transition function at 0.09375dB/fs (IVTM bit = “1”). Therefore no switching noise occurs during the transition. When IVTM bit = “01”, it takes 944/fs (21.4ms@fs=44.1kHz) from F1H(+36dB) to 05H(-52.5dB). The volume is muted after transitioned to -72dB (208/fs=4.7ms @fs=44.1kHz) in the period set by IVTM bit when changing the volume from 05H (-52.5dB) to 00H (MUTE). When IVA/BL7-0 bits and IVA/BR bits are set in series, should be set at soft transition time interval

If IVA/BL7-0 or IVA/BR7-0 bits are written during PMADA/BL = PMADA/BR bits = “0”, IVOL operation starts with the written values after PMADA/BL or PMADA/BR bits are changed to “1” waiting the ADC initialization cycle time.

IVA/BL7-0 bits IVA/BR7-0 bits	GAIN [dB]	Step
F1H	+36.0	0.375 dB (default)
E0H	+35.625	
EFH	+35.25	
:	:	
E1H	+30.0	
:	:	
92H	+0.375	
91H	0.0	
90H	-0.375	
:	:	
06H	-52.125	
05H	-52.5	
04H ~ 00H	MUTE	

Table 39. Input Digital Volume Setting

IVTM bit	Transition Time from F1H to 05H (IVA/BL7-0, IVA/BR7-0 bits)		
	Setting	fs=8kHz	fs=44.1kHz
0	236/fs	29.5ms	5.4ms
1	944/fs	118ms	21.4ms

Table 40. Transition Time Setting of Input Digital Volume

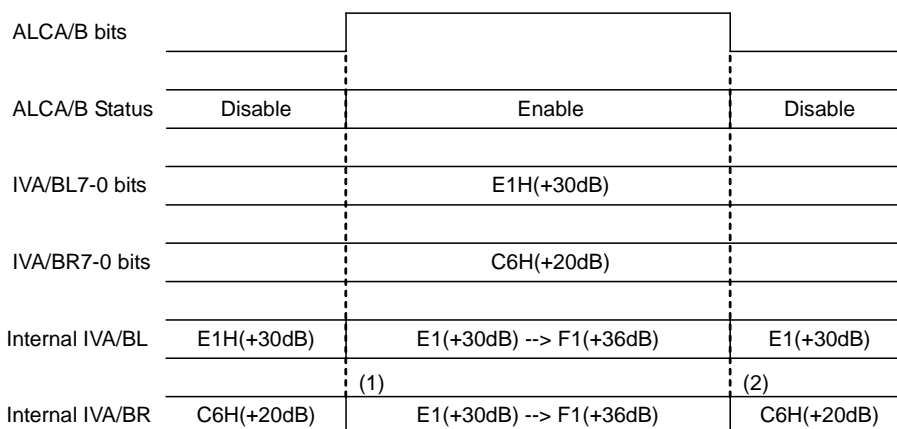

Figure 37. Example of IVOL value during 2ch ALC (ALC4 bit = “0”)

- (1) The IVA/BL value becomes the start value if the IVA/BL and IVA/BR are different when an ALC operation starts. The wait time from ALCA/B bits = “1” to ALC operation start by IVA/BL7-0 bits is at most recovery time (WTM1-0 bits).
- (2) Writing to IVA/BL and IVA/BR registers (07H, 08H, 17H and 18H) is ignored during ALC operation. After ALC is disabled, the IVOL changes to each IVA/BL or IVA/BR value by soft transition. When ALC is enabled again, ALCA/B bit should be set to “1” with an interval more than soft transition time after ALCA/B bit = “0”.

■ ALC 4ch Link Mode sequence

Figure 38 shows the 4ch Link ALC Mode sequence at ALCA bit = ALCB bit = “0”, when ALC4 bit = “0” → “1”.

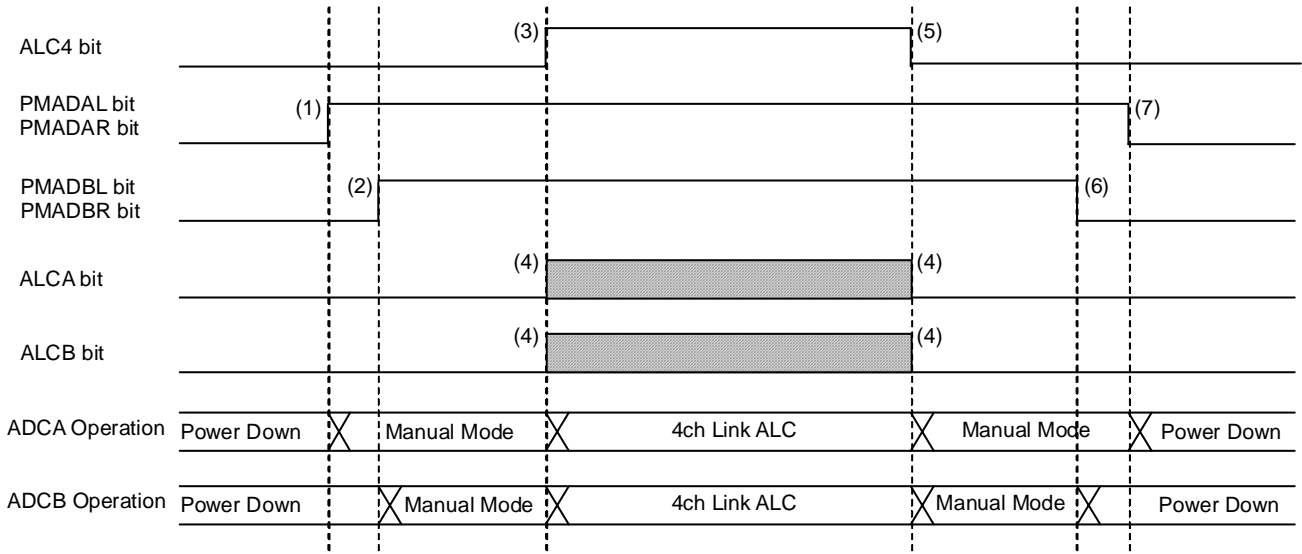

Figure 38. 4ch Link ALC Mode Sequence (ALC4 bit = “1”)

- (1) ADCA is powered up by PMADAL bit and PMADAR bit are changed from “0” to “1”.
- (2) ADCB is powered up by PMADBL bit and PMADBR bit are changed from “0” to “1”.
- (3) Both ADCA and ADCB start ALC operation together (4ch Link ALC) by changing ALC4 bit from “0” to “1”. At this point the start value of ALC is Lch of ADCA (IVAL7-0 bits).
- (4) When ALC4 bit = “1”, ALCA bit and ALCB bit become invalid. But these bits should be “0”, when ALC4 bit is changed.
- (5) When ALC4 bit = “1” → “0”, ADCA and ADCB become Manual Mode. 2ch link mode can also be set without stopping operation by setting ALCA and ALCB bits = “1”.
- (6) ADCB is powered down by setting PMADBL bit and PMADBR bit “0”.
- (7) ADCA is powered down by setting PMADAL bit and PMADAR bit “0”.

■ Serial Control Interface

(1) 3-wire Serial Control Mode (I2C pin = "L")

(1)-1. Data Writing and Reading Modes on Every Address

One data is written to (read from) one address. Internal registers may be written by using 3-wire serial interface pins (CSN, CCLK and CDTIO). The data on this interface consists of Read/Write, Register address (MSB first, 6bits) and Control data or Output data (MSB first, 8bits). Address and data is clocked in on the rising edge of CCLK and data is clocked out on the falling edge. Data writings become available on the rising edge of CSN. When reading the data, the CDTIO pin changes to output mode at the falling edge of 8th CCLK and outputs data in D7-D0. However this reading function is available only when READ bit = "1". When READ bit = "0", the CDTIO pin stays as Hi-Z even after the falling edge of 8th CCLK. The data output finishes on the rising edge of CSN. The CDTIO is placed in a Hi-Z state except when outputting the data at read operation mode. Clock speed of CCLK is 5MHz (max). The value of internal registers are initialized by the PDN pin = "L".

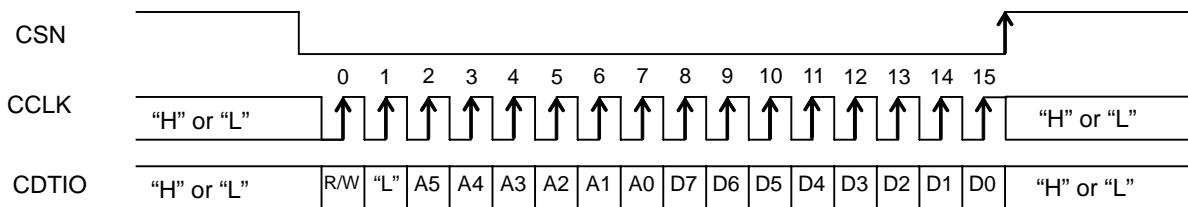

R/W: READ/WRITE ("1": WRITE, "0": READ)
 A5-A0: Register Address
 D7-D0: Control data (Input) at Write Control Command
 Output data (Output) at Read Control Command

Figure 39. Serial Control Interface Timing 1

(1)-2. Continuous Data Writing Mode

Address is incremented automatically and data is written continuously. This mode does not support reading. When the written address reaches 37H, it is automatically incremented to 00H.

In this mode, registers are written by 3-wire serial interface pins (CSN, CCLK and CDTIO). The data on this interface consists of Read/Write (1bit, Fixed to "1"), Register address (MSB-first, 6bits) and Control data or Output data (MSB-first, 8xN bits). The receiving data is latched on a rising edge ("↑") of CCLK. The first write data becomes effective between the rising edge ("↑") and the falling edge ("↓") of 16th CCLK. When the micro processor continues sending CDTIO and CCLK clocks while the CSN pin = "L", the address counter is incremented automatically and writing data becomes effective between the rising edge ("↑") and the falling edge ("↓") of every 8th CCLK. For the last address, writing data becomes effective between the rising edge ("↑") of 8th CCLK and the rising edge ("↑") of CSN. The clock speed of CCLK is 5MHz (max). The internal registers are initialized by the PDN pin = "L".

Even through the writing data does not reach the last address; a write command can be completed when the CSN pin is set to "H".

Note 33. When CSN “↑” was written before “↑” of 8th CCLK in continuous data writing mode, the previous data writing address becomes valid and the writing address is ignored.

Note 34. After 8bits data in the last address became valid, put the CSN pin “H” to complete the write command. If the CDTIO and CCLK inputs are continued when the CSN pin = “L”, the data in the next address, which is incremented, is over written.

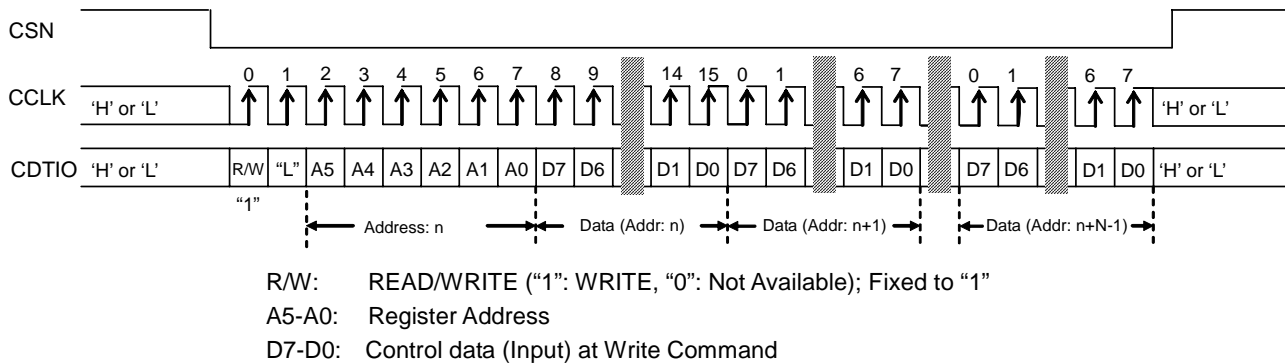

Figure 40. Serial Control Interface Timing 2 (Continuous Writing Mode)

(2) I2C-bus Control Mode (I2C pin = "H")

The AK5703 supports the fast-mode I²C-bus (max: 400kHz). Pull-up resistors at the SDA and SCL pins must be connected to (TVDD+0.3)V or less voltage.

(2)-1. WRITE Operations

Figure 41 shows the data transfer sequence for the I²C-bus mode. All commands are preceded by a START condition. A HIGH to LOW transition on the SDA line while SCL is HIGH indicates a START condition (Figure 47). After the START condition, a slave address is sent. This address is 7 bits long followed by the eighth bit that is a data direction bit (R/W). The most significant six bits of the slave address are fixed as "001001". The next bit is CAD0 (device address bit). This bit identifies the specific device on the bus. The hard-wired input pin (CAD0 pin) sets these device address bits (Figure 42). If the slave address matches that of the AK5703, the AK5703 generates an acknowledge and the operation is executed. The master must generate the acknowledge-related clock pulse and release the SDA line (HIGH) during the acknowledge clock pulse (Figure 48). A R/W bit value of "1" indicates that the read operation is to be executed, and "0" indicates that the write operation is to be executed.

The second byte consists of the control register address of the AK5703. The format is MSB first, and those most significant 2bit is fixed to zero (Figure 43). The data after the third byte contains control data. The format is MSB first, 8bits (Figure 44). The AK5703 generates an acknowledge after each byte is received. Data transfer is always terminated by a STOP condition generated by the master. A LOW to HIGH transition on the SDA line while SCL is HIGH defines a STOP condition (Figure 47).

The AK5703 can perform more than one byte write operation per sequence. After receipt of the third byte the AK5703 generates an acknowledge and awaits the next data. The master can transmit more than one byte instead of terminating the write cycle after the first data byte is transferred. After receiving each data packet the internal address counter is incremented by one, and the next data is automatically taken into the next address. If the address exceeds "37H" prior to generating a stop condition, the address counter will "roll over" to 00H and the previous data will be overwritten.

The data on the SDA line must remain stable during the HIGH period of the clock. HIGH or LOW state of the data line can only be changed when the clock signal on the SCL line is LOW (Figure 49) except for the START and STOP conditions.

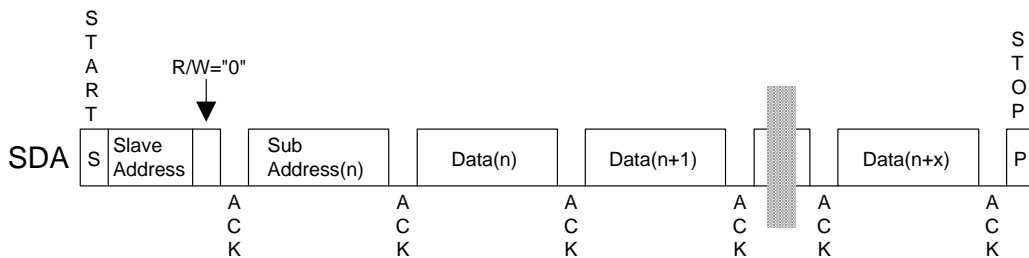

Figure 41. Data Transfer Sequence at I²C Bus Mode

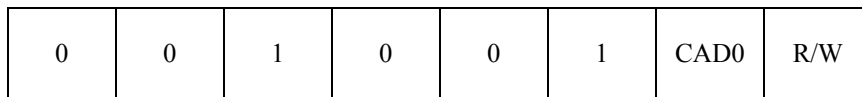

Figure 42. The First Byte

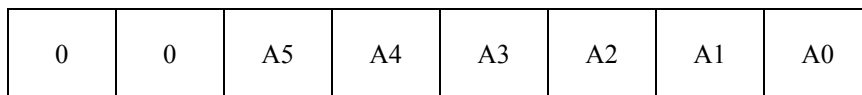

Figure 43. The Second Byte

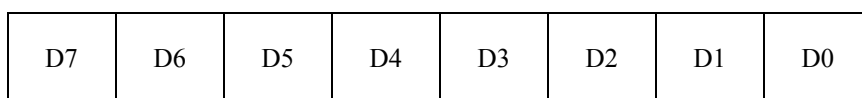

Figure 44. The Third Byte

(2)-2. READ Operations

Set the R/W bit = "1" for the READ operation of the AK5703. After transmission of data, the master can read the next address's data by generating an acknowledge instead of terminating the write cycle after the receipt of the first data word. After receiving each data packet the internal address counter is incremented by one, and the next data is automatically taken into the next address. If the address exceeds 37H prior to generating stop condition, the address counter will "roll over" to 00H and the data of 00H will be read out.

The AK5703 supports two basic read operations: CURRENT ADDRESS READ and RANDOM ADDRESS READ.

(2)-2-1. CURRENT ADDRESS READ

The AK5703 has an internal address counter that maintains the address of the last accessed word incremented by one. Therefore, if the last access (either a read or write) were to address "n", the next CURRENT READ operation would access data from the address "n+1". After receipt of the slave address with R/W bit "1", the AK5703 generates an acknowledge, transmits 1-byte of data to the address set by the internal address counter and increments the internal address counter by 1. If the master does not generate an acknowledge but generates a stop condition instead, the AK5703 ceases the transmission.

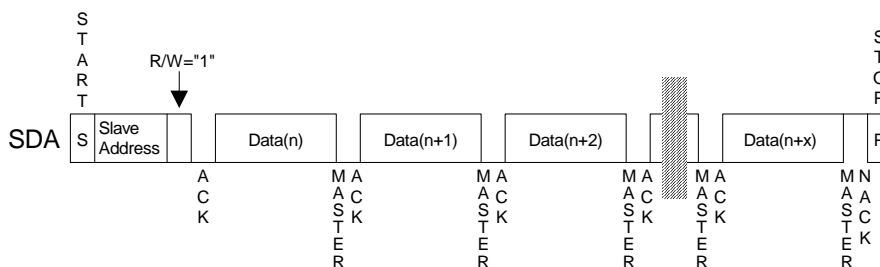

Figure 45. Current Address Read

(2)-2-2. RANDOM ADDRESS READ

The random read operation allows the master to access any memory location at random. Prior to issuing the slave address with the R/W bit "1", the master must first perform a "dummy" write operation. The master issues a start request, a slave address (R/W bit = "0") and then the register address to read. After the register address is acknowledged, the master immediately reissues the start request and the slave address with the R/W bit "1". The AK5703 then generates an acknowledge, 1 byte of data and increments the internal address counter by 1. If the master does not generate an acknowledge but generates a stop condition instead, the AK5703 ceases the transmission.

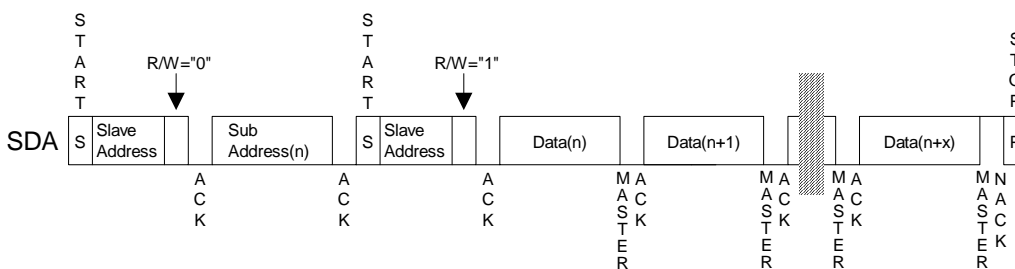

Figure 46. Random Address Read

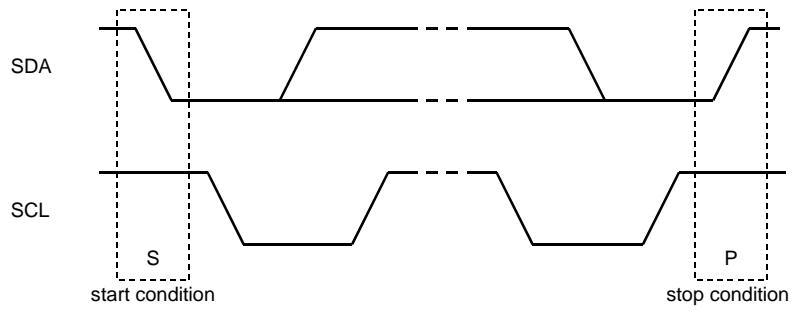

Figure 47. Start Condition and Stop Condition

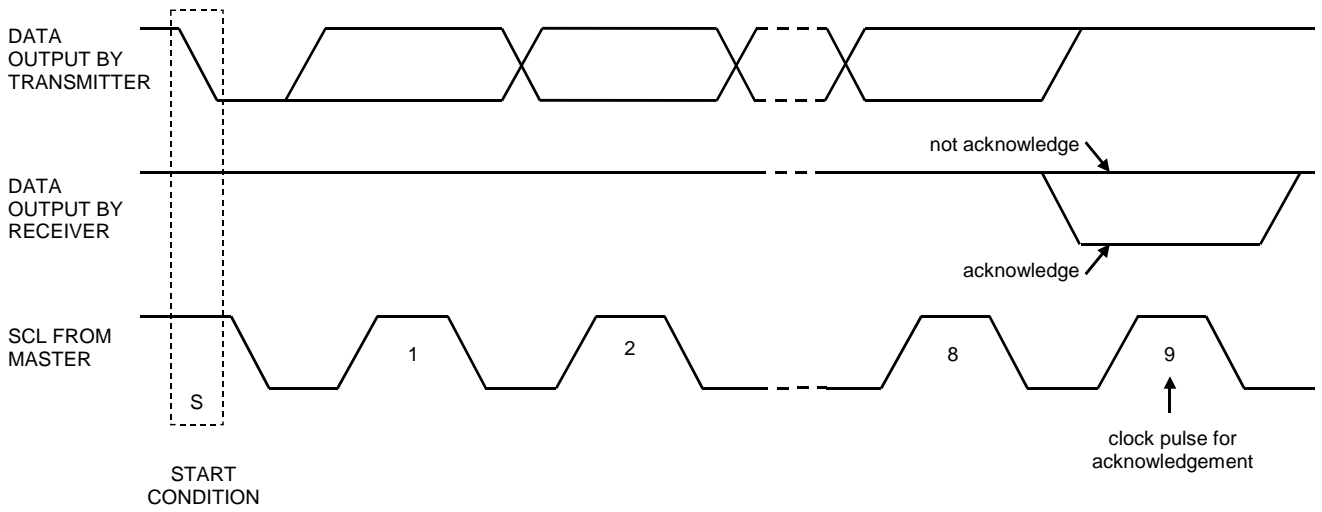

Figure 48. Acknowledge (I²C Bus)

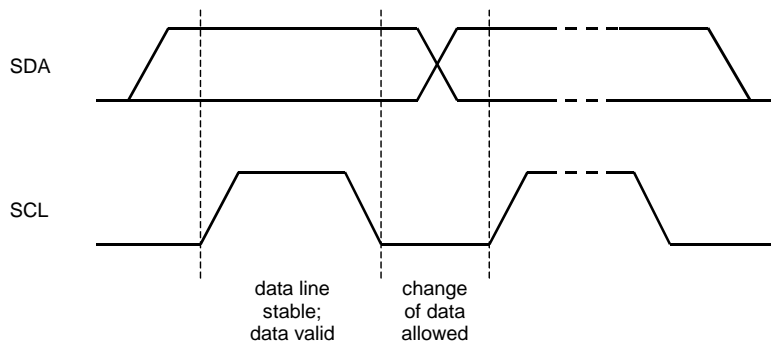

Figure 49. Bit Transfer (I²C Bus)

■ Register Map

Addr	Register Name	D7	D6	D5	D4	D3	D2	D1	D0
00H	Power Management A	0	MIXA	0	0	PMMPA	PMVCM	PMADAR	PMADAL
01H	PLL Control A	READ	0	PLL3	PLL2	PLL1	PLL0	M/S	PMPLL
02H	Signal & Mic Gain Select A	HPFADA	MGAINA2	MGAINA1	MGAINA0	0	0	MDIFA2	MDIFA1
03H	Mic Gain Adjust A0	DIF1	DIF0	0	0	MGAL3	MGAL2	MGAL1	MGAL0
04H	Mic Gain Adjust A1	TDM1	TDM0	BCKO1	BCKO0	MGAR3	MGAR2	MGAR1	MGAR0
05H	fs Select & Filter Control A	HPFA1	HPFA0	LPFA	HPF2A	FS3	FS2	FS1	FS0
06H	Clock Output Select A	ADRSTA1	ADRSTA0	CM1	CM0	0	MCKO	PS1	PS0
07H	Lch Input Volume Control A	IVAL7	IVAL6	IVAL5	IVAL4	IVAL3	IVAL2	IVAL1	IVAL0
08H	Rch Input Volume Control A	IVAR7	IVAR6	IVAR5	IVAR4	IVAR3	IVAR2	IVAR1	IVAR0
09H	Timer Select A	IVOLAC	0	RFSTA1	RFSTA0	FRATT	IVTM	WTM1	WTM0
0AH	ALC Mode Control A0	ALCA	ALC4	ALCEQN	RGAINA2	RGAINA1	RGAINA0	LMTHA1	LMTHA0
0BH	ALC Mode Control A1	REFA7	REFA6	REFA5	REFA4	REFA3	REFA2	REFA1	REFA0
0CH	L1 Ch Output Delay Control	DLY1L	0	DLY1L5	DLY1L4	DLY1L3	DLY1L2	DLY1L1	DLY1L0
0DH	R1 Ch Output Delay Control	DLY1R	0	DLY1R5	DLY1R4	DLY1R3	DLY1R2	DLY1R1	DLY1R0
0EH	Reserved	0	0	0	0	0	0	0	0
0FH	Reserved	0	0	0	0	0	0	0	0

Addr	Register Name	D7	D6	D5	D4	D3	D2	D1	D0
10H	Power Management B	0	MIXB	0	0	PMMPB	0	PMADBR	PMADBL
11H	Reserved	0	0	0	0	0	0	0	0
12H	Signal & Mic Gain Select B	HPFADB	MGAINB2	MGAINB1	MGAINB0	0	0	MDIFB2	MDIFB1
13H	Mic Gain Adjust B0	0	0	0	0	MGBL3	MGBL2	MGBL1	MGBL0
14H	Mic Gain Adjust B1	0	0	0	0	MGBR3	MGBR2	MGBR1	MGBR0
15H	Filter Control B	HPFB1	HPFB0	LPFB	HPF2B	0	0	0	0
16H	Clock Output Select B	ADRSTB1	ADRSTB0	0	0	0	0	0	0
17H	Lch Input Volume Control B	IVBL7	IVBL6	IVBL5	IVBL4	IVBL3	IVBL2	IVBL1	IVBL0
18H	Rch Input Volume Control B	IVBR7	IVBR6	IVBR5	IVBR4	IVBR3	IVBR2	IVBR1	IVBR0
19H	Timer Select B	IVOLBC	0	RFSTB1	RFSTB0	0	0	0	0
1AH	ALC Mode Control B0	ALCB	0	0	RGAINB2	RGAINB1	RGAINB0	LMTHB1	LMTHB0
1BH	ALC Mode Control B1	REFB7	REFB6	REFB5	REFB4	REFB3	REFB2	REFB1	REFB0
1CH	L2 Ch Output Delay Control	DLY2L	0	DLY2L5	DLY2L4	DLY2L3	DLY2L2	DLY2L1	DLY2L0
1DH	R2 Ch Output Delay Control	DLY2R	0	DLY2R5	DLY2R4	DLY2R3	DLY2R2	DLY2R1	DLY2R0
1EH	Reserved	0	0	0	0	0	0	0	0
1FH	Reserved	0	0	0	0	0	0	0	0

Addr	Register Name	D7	D6	D5	D4	D3	D2	D1	D0
20H	HPFA2 Co-efficient 0	FA1A7	FA1A6	FA1A5	FA1A4	FA1A3	FA1A2	FA1A1	FA1A0
21H	HPFA2 Co-efficient 1	0	0	FA1A13	FA1A12	FA1A11	FA1A10	FA1A9	FA1A8
22H	HPFA2 Co-efficient 2	FA1B7	FA1B6	FA1B5	FA1B4	FA1B3	FA1B2	FA1B1	FA1B0
23H	HPFA2 Co-efficient 3	0	0	FA1B13	FA1B12	FA1B11	FA1B10	FA1B9	FA1B8
24H	LPFA Co-efficient 0	FA2A7	FA2A6	FA2A5	FA2A4	FA2A3	FA2A2	FA2A1	FA2A0
25H	LPFA Co-efficient 1	0	0	FA2A13	FA12	FA2A11	FA2A10	FA2A9	FA2A8
26H	LPFA Co-efficient 2	FA2B7	FA2B6	FA2B5	FA2B4	FA2B3	FA2B2	FA2B1	FA2B0
27H	LPFA Co-efficient 3	0	0	FA2B13	FB12	FA2B11	FA2B10	FA2B9	FA2B8
28H ~ 2FH	Reserved	0	0	0	0	0	0	0	0

Addr	Register Name	D7	D6	D5	D4	D3	D2	D1	D0
30H	HPFB2 Co-efficient 0	FB1A7	FB1A6	FB1A5	FB1A4	FB1A3	FB1A2	FB1A1	FB1A0
31H	HPFB2 Co-efficient 1	0	0	FB1A13	FB1A12	FB1A11	FB1A10	FB1A9	FB1A8
32H	HPFB2 Co-efficient 2	FB1B7	FB1B6	FB1B5	FB1B4	FB1B3	FB1B2	FB1B1	FB1B0
33H	HPFB2 Co-efficient 3	0	0	FB1B13	FB1B12	FB1B11	FB1B10	FB1B9	FB1B8
34H	LPFB Co-efficient 0	FB2A7	FB2A6	FB2A5	FB2A4	FB2A3	FB2A2	FB2A1	FB2A0
35H	LPFB Co-efficient 1	0	0	FB2A13	FA12	FB2A11	FB2A10	FB2A9	FB2A8
36H	LPFB Co-efficient 2	FB2B7	FB2B6	FB2B5	FB2B4	FB2B3	FB2B2	FB2B1	FB2B0
37H	LPFB Co-efficient 3	0	0	FB2B13	FB12	FB2B11	FB2B10	FB2B9	FB2B8

Note 35. PDN pin = "L" resets the registers to their default values.

Note 36. The bits defined as 0 must contain a "0" value.

■ Register Definitions

Addr	Register Name	D7	D6	D5	D4	D3	D2	D1	D0
00H	Power Management A	0	MIXA	0	0	PMMPA	PMVCM	PMADAR	PMADAL
	R/W	R	R/W	R	R	R/W	R/W	R/W	R/W
	Default	0	0	0	0	0	0	0	0

PMADAL: MIC-Amp A Lch and ADCA Lch Power Management

0: Power down (default)

1: Power up

PMADAR: MIC-Amp A Rch and ADCA Rch Power Management

0: Power down (default)

1: Power up

When the PMADAL or PMADAR bit is changed from “0” to “1”, the initialization cycle (1059/fs=24ms @44.1kHz, ADRSTA1-0 bits = “00”) starts. After initializing, digital data of the ADC is output.

PMVCM: VCOM Power Management

0: Power down (default)

1: Power up

PMVCM bit must be “1” when one of blocks is powered-up. PMVCM bit can only be “0” when all power management bits (PMADAL, PMADAR, PMADBL, PMADBR, PMMPA, PMMPB, PMPLL and MCKO) are “0”.

PMMPA: MPWRA pin Power Management

0: Power down: Hi-Z (default)

1: Power up

MIXA: ADCA Output Data Select ([Table 27](#))

0: Normal operation (default)

1: (L+R)/2

Each block can be powered-down respectively by writing “0” in each bit of this address. When the PDN pin is “L”, all blocks are powered-down regardless as setting of this address. In this case, register is initialized to the default value.

When PMVCM, PMADAL, PMADAR, PMADBL, PMADBR, PMMPA, PMMPB, PMPLL and MCKO bits are “0”, all blocks are powered-down. The register values remain unchanged.

When the all ADC is powered-down, external clocks may not be present. When one of the ADC is powered -up, external clocks must always be present.

Addr	Register Name	D7	D6	D5	D4	D3	D2	D1	D0
01H	PLL Control A	READ	0	PLL3	PLL2	PLL1	PLL0	M/S	PMPLL
	R/W	R/W	R	R/W	R/W	R/W	R/W	R/W	R/W
	Default	0	0	0	1	1	0	0	0

PMPLL: PLL Power Management

0: EXT Mode and Power Down (default)

1: PLL Mode and Power up

M/S: Master / Slave Mode Select

0: Slave Mode (default)

1: Master Mode

PLL3-0: PLL Reference Clock Select ([Table 4](#))

Default: "0110" (MCKI pin=12MHz)

READ: Read Function Enable

0: Disable (default)

1: Enable

Addr	Register Name	D7	D6	D5	D4	D3	D2	D1	D0
02H	Mic Gain & Signal Select A	HPFADA	MGAINA2	MGAINA1	MGAINA0	0	0	MDIFA2	MDIFA1
	R/W	R/W	R/W	R/W	R/W	R	R	R/W	R/W
	Default	0	1	1	0	0	0	0	0

MDIFA1: ADCA Lch Input Type Select

0: Single-ended Input (LIN1 pin: Default)

1: Full-differential Input (LINA+/LINA- pins)

MDIFA2: ADCA Rch Input Type Select

0: Single-ended Input (RIN1 pin: Default)

1: Full-differential Input (RINA+/RINA- pins)

MGAINA2-0: MIC-Amp A Gain Control ([Table 22](#))

Default: "110" (+30dB)

HPFADA: HPF1A Enable

0: Disable (default)

1: Enable

While using ADCA, HPFADA bit should be set to "1".

Addr	Register Name	D7	D6	D5	D4	D3	D2	D1	D0
03H	Mic Gain Adjust A0	DIF1	DIF0	0	0	MGAL3	MGAL2	MGAL1	MGAL0
	R/W	R/W	R/W	R	R	R/W	R/W	R/W	R/W
	Default	1	1	0	0	0	1	0	0

MGAL3-0: ADCA Lch MIC Gain Adjust ([Table 26](#))

Default: "4H" (0dB)

DIF1-0: Audio Interface Format ([Table 17](#), [Table 18](#), [Table 19](#))

Default: "11" (24bit/16bit I²S compatible)

Addr	Register Name	D7	D6	D5	D4	D3	D2	D1	D0
04H	Mic Gain Adjust A1	TDM1	TDM0	BCKO1	BCKO0	MGAR3	MGAR2	MGAR1	MGAR0
	R/W	R/W	R/W	R/W	R/W	R/W	R/W	R/W	R/W
	Default	0	0	0	0	0	1	0	0

MGAR3-0: ADCA Rch Gain Adjust (Table 26)

Default: "4H" (0dB)

BCKO1-0: BCLK Output Frequency Select at Master Mode (Table 10, Table 15)

Default: "00" (32fs)

TDM1-0: TDM Format Select (Table 17, Table 18, Table 19)

Default: "00" (Stereo Mode)

Addr	Register Name	D7	D6	D5	D4	D3	D2	D1	D0
05H	Filter Control A & fs Select	HPF1A1	HPF1A0	LPFA	HPF2A	FS3	FS2	FS1	FS0
	R/W	R/W	R/W	R/W	R/W	R/W	R/W	R/W	R/W
	Default	0	0	0	0	1	1	1	1

FS3-0: Sampling Frequency (Table 5, Table 12, Table 14)

Default: "1111" (44.1kHz)

HPF2A: HPF2A Coefficient Setting Enable

0: Disable (default)

1: Enable

When HPF2A bit is "1", the settings of FA1A13-0 and FA1B13-0 bits are enabled. When HPF2A bit is "0", the audio data passes the HPF2A block by is 0dB gain.

LPFA: LPFA Coefficient Setting Enable

0: Disable (default)

1: Enable

When LPFA bit is "1", the settings of FA2A13-0 and FA2B13-0 bits are enabled. When LPFA bit is "0", the audio data passes the LPFA block by is 0dB gain.

HPF1A1-0: Cut-off Frequency Setting of HPF1A (Table 25)

Default: "00" ($f_c=3.4\text{Hz}@f_s=44.1\text{kHz}$)

Addr	Register Name	D7	D6	D5	D4	D3	D2	D1	D0
06H	Clock Output Select A	ADRSTA1	ADRSTA0	CM1	CM0	0	MCKO	PS1	PS0
	R/W	R/W	R/W	R/W	R/W	R	R/W	R/W	R/W
	Default	0	0	0	0	0	0	0	0

PS1-0: MCKO Output Frequency Select (Table 9)

Default: "00" (256fs)

MCKO: Master Clock Output Enable

0: Disable: MCKO pin = "L" (default)

1: Enable: Output frequency is selected by PS1-0 bits.

CM1-0: MCKI Input Frequency Select at EXT Mode (Table 9)

Default: "00" (256fs; 24kHz ~ 48kHz)

ADRSTA1-0: ADCA Initialization Cycle (Table 16)

Default: "00" (1059/fs)

Addr	Register Name	D7	D6	D5	D4	D3	D2	D1	D0
07H	Lch Input Volume Control A	IVAL7	IVAL6	IVAL5	IVAL4	IVAL3	IVAL2	IVAL1	IVAL0
08H	Rch Input Volume Control A	IVAR7	IVAR6	IVAR5	IVAR4	IVAR3	IVAR2	IVAR1	IVAR0
	R/W	R/W	R/W	R/W	R/W	R/W	R/W	R/W	R/W
	Default	1	0	0	1	0	0	0	1

IVAL7-0, IVAR7-0: Input Digital Volume; 0.375dB step, 242 Level (Table 39)
Default: "91H" (0dB)

Addr	Register Name	D7	D6	D5	D4	D3	D2	D1	D0
09H	Timer Select A	IVOLAC	0	RFSTA1	RFSTA0	FRATT	IVTM	WTM1	WTM0
	R/W	R/W	R	R/W	R/W	R/W	R/W	R/W	R/W
	Default	1	0	0	0	0	1	0	0

WTM1-0: ALC Recovery Waiting Period (Table 33)
Default: "00" (128/fs)

IVTM: Input Digital Volume Soft Transition Time Setting (Table 40)
0: 236/fs
1: 944/fs (default)

FRATT: ATT Amount for Reference Volume of Fast Recovery (Table 37)
0: -0.00106dB (4/fs) (default)
1: -0.00106dB (16/fs)

RFSTA1-0: ALCA First recovery Speed (Table 36)
Default: "00" (0.0032dB)

IVOLAC: Input Digital Volume A Control Mode Select
0: Independent
1: Dependent (default)

When IVOLAC bit = "1", IVAL7-0 bits control both Lch and Rch volume levels, while register values of IVAL7-0 bits are not written to IVAR7-0 bits. When IVOLAC bit = "0", IVAL7-0 bits control Lch level and IVAR7-0 bits control Rch level, respectively.

Addr	Register Name	D7	D6	D5	D4	D3	D2	D1	D0
0AH	ALC Mode Control A0	ALCA	ALC4	ALCEQN	RGAINA2	RGAINA1	RGAINA0	LMTHA1	LMTHA0
	R/W	R/W	R/W	R/W	R/W	R/W	R/W	R/W	R/W
	Default	0	0	0	0	0	0	0	0

LMTHA1-0: ALCA Limiter Detection Level / Recovery Counter Reset Level (Table 31)

Default: "00"

RGAINA2-0: ALCA Recovery Gain Step (Table 34)

Default: "000" (0.00424dB)

ALCEQN: ALC EQ Disable

0: ALC EQ Enable (default)

1: ALC EQ Disable

ALC4: ALC 4ch Link Enable (Table 30)

0: ALC 4ch Link Disable (default)

1: ALC 4ch Link Enable

ALCA: ALCA Enable (Table 30)

0: ALCA Disable (default)

1: ALCA Enable

Addr	Register Name	D7	D6	D5	D4	D3	D2	D1	D0
0BH	ALC Mode Control A1	REFA7	REFA6	REFA5	REFA4	REFA3	REFA2	REFA1	REFA0
	R/W	R/W	R/W	R/W	R/W	R/W	R/W	R/W	R/W
	Default	1	1	1	0	0	0	0	1

REFA7-0: Reference Value at ALCA Recovery Operation; 0.375dB step, 242 Level (Table 35)

Default: "E1H" (+30.0dB)

Addr	Register Name	D7	D6	D5	D4	D3	D2	D1	D0
0CH	L1 Ch Output Delay Control	DLY1L	0	DLY1L5	DLY1L4	DLY1L3	DLY1L2	DLY1L1	DLY1L0
	R/W	R/W	R	R/W	R/W	R/W	R/W	R/W	R/W
	Default	0	0	0	0	0	0	0	0

DLY1L5-0: Programmable Output Data Delay (Table 24)

"00H": 1/64fs (default)

DLY1L: Programmable Output Data Delay Enable for L1 Channel

0: Disable (default)

1: Enable

When DLY1L bit is "1", the settings of DLY1L5-0 bits are enabled. When DLY1L bit is "0", the audio data of the L1 channel block is not delayed.

Addr	Register Name	D7	D6	D5	D4	D3	D2	D1	D0
0DH	R1 Ch Output Delay Control	DLY1R	0	DLY1R5	DLY1R4	DLY1R3	DLY1R2	DLY1R1	DLY1R0
	R/W	R/W	R	R/W	R/W	R/W	R/W	R/W	R/W
	Default	0	0	0	0	0	0	0	0

DLY1R5-0: Programmable Output Data Delay ([Table 24](#))

“00H”: 1/64fs (default)

DLY1R: Programmable Output Data Delay Enable for R1 Channel

0: Disable (default)

1: Enable

When DLY1R bit is “1”, the settings of DLY1R5-0 bits are enabled. When DLY1R bit is “0”, the audio data of the R1 channel block is not delayed.

Addr	Register Name	D7	D6	D5	D4	D3	D2	D1	D0
10H	Power Management B	0	MIXB	0	0	PMMPB	0	PMADBR	PMADBL
	R/W	R	R/W	R	R	R/W	R	R/W	R/W
	Default	0	0	0	0	0	0	0	0

PMADBL: MIC-Amp B Lch and ADCB Lch Power Management

0: Power down (default)

1: Power up

PMADBR: MIC-Amp B Rch and ADCB Rch Power Management

0: Power down (default)

1: Power up

When the PMADBL or PMADBR bit is changed from “0” to “1”, the initialization cycle (1059/fs=24ms @44.1kHz, ADRSTB1-0 bits = “00”) starts. After initializing, digital data of the ADC is output.

PMMPB: MPWRB pin Power Management

0: Power down: Hi-Z (default)

1: Power up

MIXB: ADCB Output Data Select ([Table 27](#))

0: Normal operation (default)

1: (L+R)/2

Each block can be powered-down respectively by writing “0” in each bit of this address. When the PDN pin is “L”, all blocks are powered-down regardless as setting of this address. In this case, register is initialized to the default value.

When PMVCM, PMADAL, PMADAR, PMADBL, PMADBR, PMMPA, PMMPB, PMPLL and MCKO bits are “0”, all blocks are powered-down. The register values remain unchanged.

When the all ADC is powered-down, external clocks may not be present. When one of the ADC is powered-up, external clocks must always be present.

Addr	Register Name	D7	D6	D5	D4	D3	D2	D1	D0
12H	Mic Gain & Signal Select B	HPFADB	MGAINB2	MGAINB1	MGAINB0	0	0	MDIFB2	MDIFB1
	R/W	R/W	R/W	R/W	R/W	R	R	R/W	R/W
	Default	0	1	1	0	0	0	0	0

MDIFB1: ADCB Lch Input Type Select

0: Single-ended Input (LIN2 pin: Default)

1: Full-differential Input (LINB+/LINB- pins)

MDIFB2: ADCB Rch Input Type Select

0: Single-ended Input (RIN2 pin: Default)

1: Full-differential Input (RINB+/RINB- pins)

MGAINB2-0: MIC-Amp B Gain Control (Table 22)

Default: "110" (+30dB)

HPFADB: HPF1B Enable

0: Disable (default)

1: Enable

While using ADCB, HPFADB bit should be set to "1".

Addr	Register Name	D7	D6	D5	D4	D3	D2	D1	D0
13H	Mic Gain Adjust B0	0	0	0	0	MGBL3	MGBL2	MGBL1	MGBL0
14H	Mic Gain Adjust B1	0	0	0	0	MGBR3	MGBR2	MGBR1	MGBR0
	R/W	R	R	R	R	R/W	R/W	R/W	R/W
	Default	0	0	0	0	0	1	0	0

MGBL/R3-0: ADCB Lch/Rch MIC Gain Adjust (Table 26)

Default: "4H" (0dB)

Addr	Register Name	D7	D6	D5	D4	D3	D2	D1	D0
15H	Filter Control B	HPFB1	HPFB0	LPFB	HPF2B	0	0	0	0
	R/W	R/W	R/W	R/W	R/W	R	R	R	R
	Default	0	0	0	0	0	0	0	0

HPF2B: HPF2B Coefficient Setting Enable

0: Disable (default)

1: Enable

When HPF2BA bit is "1", the settings of FB1A13-0 and FB1B13-0 bits are enabled. When HPF2B bit is "0", the audio data passes the HPF2B block by is 0dB gain.

LPFB: LPFB Coefficient Setting Enable

0: Disable (default)

1: Enable

When LPFB bit is "1", the settings of FB2A13-0 and FB2B13-0 bits are enabled. When LPFB bit is "0", the audio data passes the LPFB block by is 0dB gain.

HPFB1-0: Cut-off Frequency Setting of HPF1B (Table 25)

Default: "00" ($f_c=3.4\text{Hz}@f_s=44.1\text{kHz}$)

Addr	Register Name	D7	D6	D5	D4	D3	D2	D1	D0
16H	Clock Output Select B	ADRSTB1	ADRSTB0	0	0	0	0	0	0
	R/W	R/W	R/W	R	R	R	R	R	R
	Default	0	0	0	0	0	0	0	0

ADRSTB1-0: ADCB Initialization Cycle (Table 16)

Default: "00" (1059/fs)

Addr	Register Name	D7	D6	D5	D4	D3	D2	D1	D0
17H	Lch Input Volume Control B	IVBL7	IVBL6	IVBL5	IVBL4	IVBL3	IVBL2	IVBL1	IVBL0
18H	Rch Input Volume Control B	IVBR7	IVBR6	IVBR5	IVBR4	IVBR3	IVBR2	IVBR1	IVBR0
	R/W	R/W	R/W	R/W	R/W	R/W	R/W	R/W	R/W
	Default	1	0	0	1	0	0	0	1

IVBL7-0, IVBR7-0: Input Digital Volume; 0.375dB step, 242 Level (Table 39)

Default: "91H" (0dB)

Addr	Register Name	D7	D6	D5	D4	D3	D2	D1	D0
19H	Timer Select B	IVOLBC	0	RFSTB1	RFSTB0	0	0	0	0
	R/W	R/W	R	R/W	R/W	R	R	R	R
	Default	1	0	0	0	0	0	0	0

RFSTB1-0: ALCB First recovery Speed (Table 36)

Default: "00" (0.0032dB)

IVOLBC: Input Digital Volume B Control Mode Select

0: Independent

1: Dependent (default)

When IVOLBC bit = "1", IVBL7-0 bits control both Lch and Rch volume levels, while register values of IVBL7-0 bits are not written to IVBR7-0 bits. When IVOLBC bit = "0", IVBL7-0 bits control Lch level and IVBR7-0 bits control Rch level, respectively.

Addr	Register Name	D7	D6	D5	D4	D3	D2	D1	D0
1AH	ALC Mode Control B0	ALCB	0	0	RGAINB2	RGAINB1	RGAINB0	LMTHB1	LMTHB0
	R/W	R/W	R	R	R/W	R/W	R/W	R/W	R/W
	Default	0	0	0	0	0	0	0	0

LMTHB1-0: ALCB Limiter Detection Level / Recovery Counter Reset Level (Table 31)

Default: "00"

RGAINB2-0: ALCB Recovery Gain Step (Table 34)

Default: "000" (0.00424dB)

ALCB: ALCB Enable (Table 30)

0: ALCB Disable (default)

1: ALCB Enable

Addr	Register Name	D7	D6	D5	D4	D3	D2	D1	D0
1BH	ALC Mode Control B1	REFB7	REFB6	REFB5	REFB4	REFB3	REFB2	REFB1	REFB0
	R/W	R/W	R/W	R/W	R/W	R/W	R/W	R/W	R/W
	Default	1	1	1	0	0	0	0	1

REFB7-0: Reference Value at ALCB Recovery Operation; 0.375dB step, 242 Level (Table 35)

Default: "E1H" (+30.0dB)

Addr	Register Name	D7	D6	D5	D4	D3	D2	D1	D0
1CH	L2 Ch Output Delay Control	DLY2L	0	DLY2L5	DLY2L4	DLY2L3	DLY2L2	DLY2L1	DLY2L0
	R/W	R/W	R	R/W	R/W	R/W	R/W	R/W	R/W
	Default	0	0	0	0	0	0	0	0

DLY2L5-0: Programmable Output Data Delay (Table 24)

"00H": 1/64fs (default)

DLY2L: Programmable Output Data Delay Enable for L2 Channel

0: Disable (default)

1: Enable

When DLY2L bit is "1", the settings of DLY2L5-0 bits are enabled. When DLY2L bit is "0", the audio data of the L2 channel block is not delayed.

Addr	Register Name	D7	D6	D5	D4	D3	D2	D1	D0
1DH	R2 Ch Output Delay Control	DLY2R	0	DLY2R5	DLY2R4	DLY2R3	DLY2R2	DLY2R1	DLY2R0
	R/W	R/W	R	R/W	R/W	R/W	R/W	R/W	R/W
	Default	0	0	0	0	0	0	0	0

DLY2R5-0: Programmable Output Data Delay (Table 24)

"00H": 1/64fs (default)

DLY2R: Programmable Output Data Delay Enable for R2 Channel

0: Disable (default)

1: Enable

When DLY2R bit is "1", the settings of DLY2R5-0 bits are enabled. When DLY2R bit is "0", the audio data of the R2 channel block is not delayed.

Addr	Register Name	D7	D6	D5	D4	D3	D2	D1	D0
20H	HPFA2 Co-efficient 0	FA1A7	FA1A6	FA1A5	FA1A4	FA1A3	FA1A2	FA1A1	FA1A0
21H	HPFA2 Co-efficient 1	0	0	FA1A13	FA1A12	FA1A11	FA1A10	FA1A9	FA1A8
22H	HPFA2 Co-efficient 2	FA1B7	FA1B6	FA1B5	FA1B4	FA1B3	FA1B2	FA1B1	FA1B0
23H	HPFA2 Co-efficient 3	0	0	FA1B13	FA1B12	FA1B11	FA1B10	FA1B9	FA1B8
R/W		R/W	R/W	R/W	R/W	R/W	R/W	R/W	R/W
Default		FA1A13-0 bits = "1FA9H", FA1B13-0 bits = "20ADH"							

FA1A13-0, FA1B13-B0: High Pass Filter (HPF2A) Coefficient (14bit x 2)

Default: FA1A13-0 bits = "1FA9H", FA1B13-0 bits = "20ADH" (fc=150Hz@fs=44.1kHz)

Addr	Register Name	D7	D6	D5	D4	D3	D2	D1	D0
24H	LPFA Co-efficient 0	FA2A7	FA2A6	FA2A5	FA2A4	FA2A3	FA2A2	FA2A1	FA2A0
25H	LPFA Co-efficient 1	0	0	FA2A13	FA12	FA2A11	FA2A10	FA2A9	FA2A8
26H	LPFA Co-efficient 2	FA2B7	FA2B6	FA2B5	FA2B4	FA2B3	FA2B2	FA2B1	FA2B0
27H	LPFA Co-efficient 3	0	0	FA2B13	FB12	FA2B11	FA2B10	FA2B9	FA2B8
R/W		R/W	R/W	R/W	R/W	R/W	R/W	R/W	R/W
Default		0	0	0	0	0	0	0	0

FA2A13-0, FA2B13-B0: Low Pass Filter (LPFA) Coefficient (14bit x 2)

Default: "0000H"

Addr	Register Name	D7	D6	D5	D4	D3	D2	D1	D0
30H	HPFB2 Co-efficient 0	FB1A7	FB1A6	FB1A5	FB1A4	FB1A3	FB1A2	FB1A1	FB1A0
31H	HPFB2 Co-efficient 1	0	0	FB1A13	FB1A12	FB1A11	FB1A10	FB1A9	FB1A8
32H	HPFB2 Co-efficient 2	FB1B7	FB1B6	FB1B5	FB1B4	FB1B3	FB1B2	FB1B1	FB1B0
33H	HPFB2 Co-efficient 3	0	0	FB1B13	FB1B12	FB1B11	FB1B10	FB1B9	FB1B8
R/W		R/W	R/W	R/W	R/W	R/W	R/W	R/W	R/W
Default		FB1A13-0 bits = "1FA9H", FB1B13-0 bits = "20ADH"							

FB1A13-0, FB1B13-B0: High Pass Filter (HPF2B) Coefficient (14bit x 2)

Default: FB1A13-0 bits = "1FA9H", FB1B13-0 bits = "20ADH" (fc=150Hz@fs=44.1kHz)

Addr	Register Name	D7	D6	D5	D4	D3	D2	D1	D0
34H	LPFB Co-efficient 0	FB2A7	FB2A6	FB2A5	FB2A4	FB2A3	FB2A2	FB2A1	FB2A0
35H	LPFB Co-efficient 1	0	0	FB2A13	FA12	FB2A11	FB2A10	FB2A9	FB2A8
36H	LPFB Co-efficient 2	FB2B7	FB2B6	FB2B5	FB2B4	FB2B3	FB2B2	FB2B1	FB2B0
37H	LPFB Co-efficient 3	0	0	FB2B13	FB12	FB2B11	FB2B10	FB2B9	FB2B8
R/W		R/W	R/W	R/W	R/W	R/W	R/W	R/W	R/W
Default		0	0	0	0	0	0	0	0

FB2A13-0, FB2B13-B0: Low Pass Filter (LPFB) Coefficient (14bit x 2)

Default: "0000H"

SYSTEM DESIGN

Figure 50 and Figure 51 show the system connection diagram. An evaluation board (AKD5703) is available for fast evaluation as well as suggestions for peripheral circuitry.

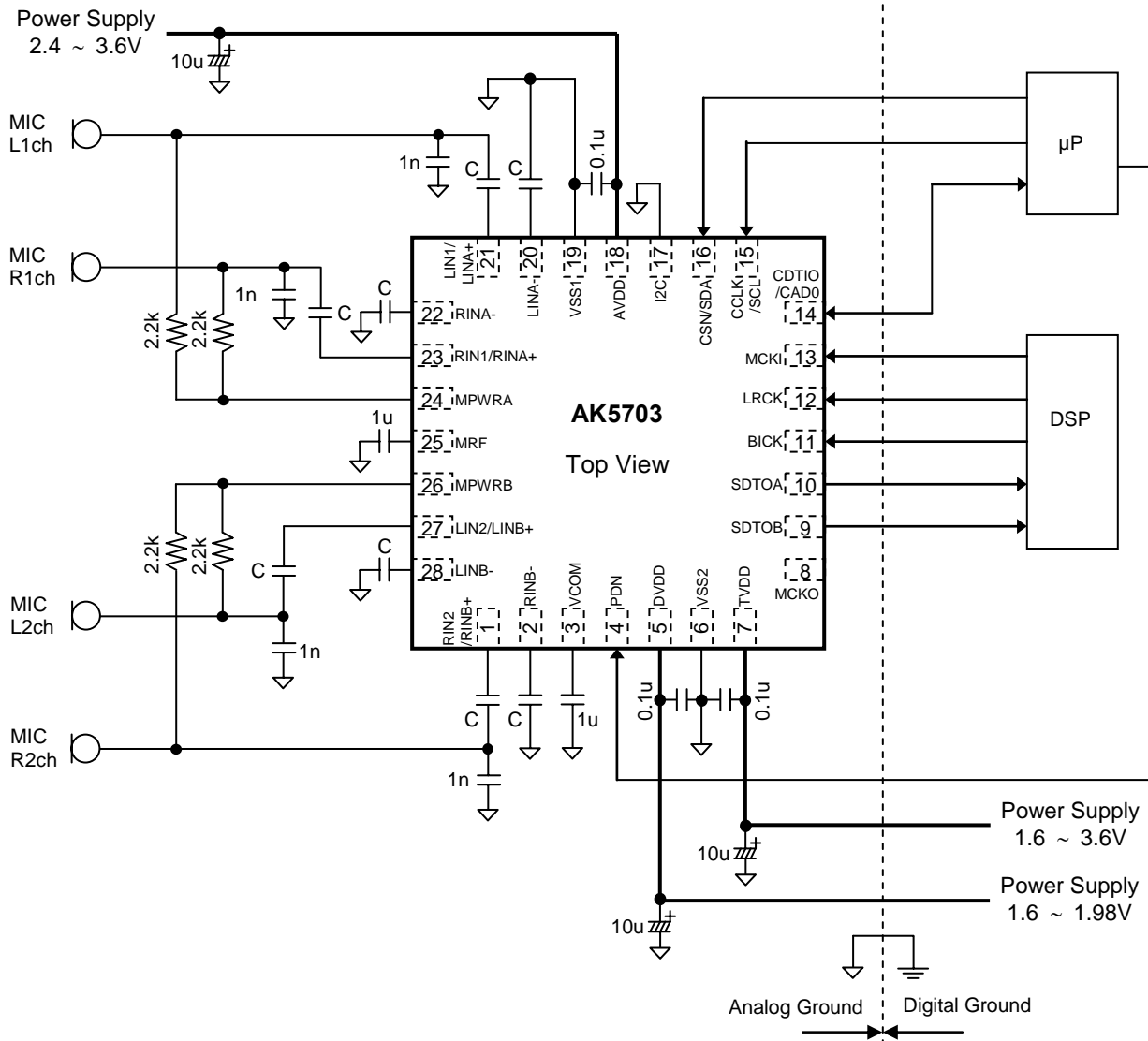

Note:

- VSS1 and VSS2 of the AK5703 must be distributed separately from the ground of external controllers.
- All digital input pins must not be allowed to float.
- Recommended AC coupling capacitors (C) of analog inputs are 0.1µF ~ 1µF. Negative input pins must be connected to VSS1 with same value capacitor in series.

Figure 50. System Connection Diagram (Single-ended Input)

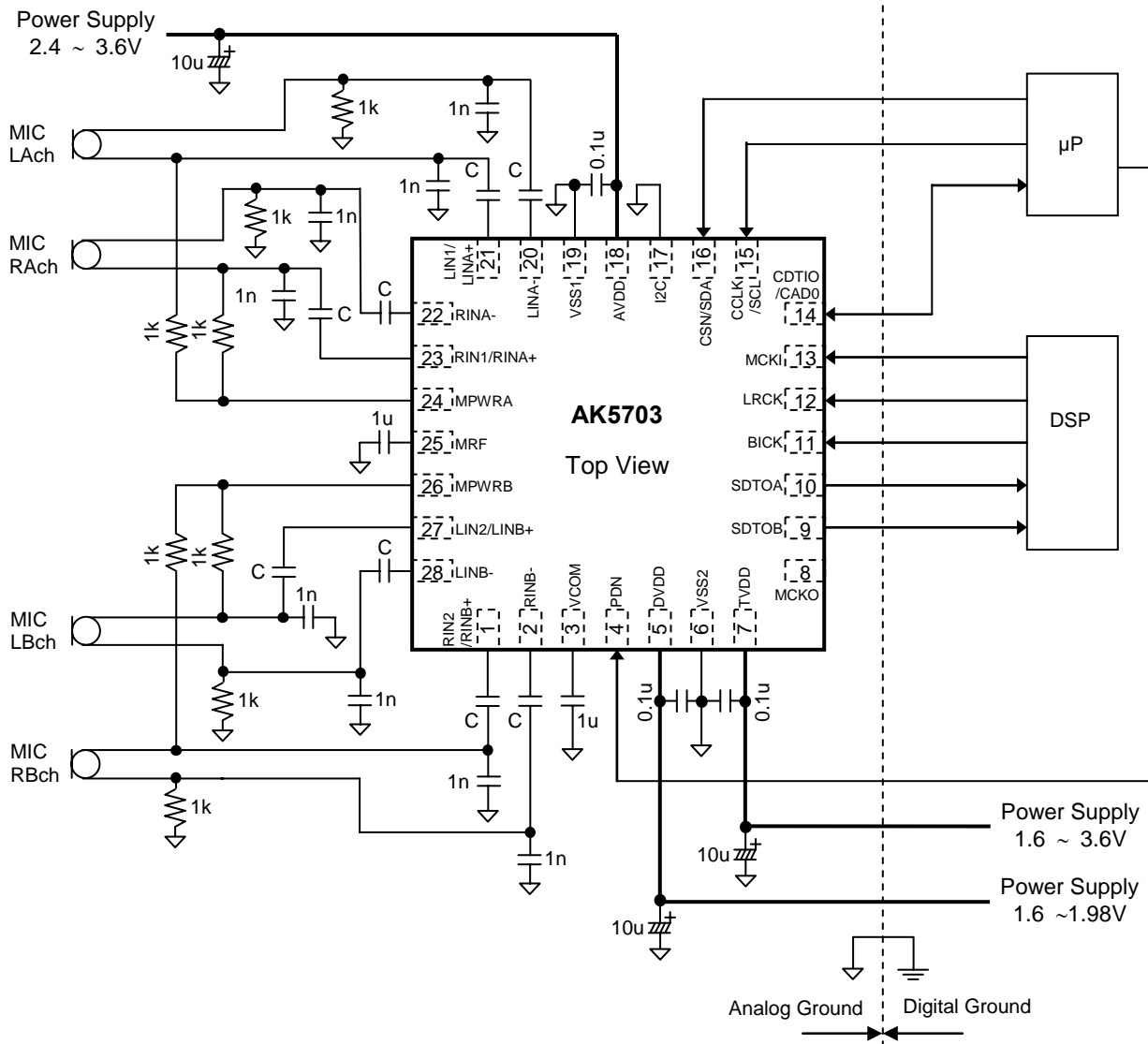

Note:

- VSS1 and VSS2 of the AK5703 must be distributed separately from the ground of external controllers.
- All digital input pins must not be allowed to float.
- Recommended AC coupling capacitors (C) of analog inputs are 0.1μF ~ 1μF.

Figure 51. System Connection Diagram (Full-differential Input)

1. Grounding and Power Supply Decoupling

The AK5703 requires careful attention to power supply and grounding arrangements. AVDD is usually supplied from the system's analog supply, and DVDD and TVDD are supplied from the system's digital power supply. If AVDD, DVDD and TVDD are supplied separately, the power-up sequence is not critical. The PDN pin should be held "L" when power supplies are tuning on. The PDN pin is allowed to be "H" after all power supplies are applied and settled.

1) Power-up

- The PDN pin should be held "L" when power supplies are turning on. The AK5703 can be reset by keeping the PDN pin "L" for 1 μ s or longer after all power supplies are applied and settled.

2) Power-down

- Each of power supplies can be powered OFF after the PDN pin is set to "L".

VSS1 and VSS2 of the AK5703 should be connected to the analog ground plane. System analog ground and digital ground should be wired separately and connected together as close as possible to where the supplies are brought onto the printed circuit board. Decoupling capacitors should be as close the power supply pins as possible. Especially, the small value ceramic capacitor is to be closest.

2. Voltage Reference

VCOM is a signal ground of this chip (typ. 0.5 x AVDD). A 1 μ F \pm 50% ceramic capacitor attached between the VCOM pin and VSS1 pin eliminates the effects of high frequency noise. It should be connected as close as possible to the VCOM pin. No load current is allowed to be drawn from the VCOM pin. All signals, especially clocks, should be kept away from the VCOM pin in order to avoid unwanted coupling into the AK5703.

3. Analog Inputs

The analog inputs are single-ended or full-differential and input resistance is 100k Ω (typ). The input signal range scales with typ. 0.6 x AVDD Vpp (@ MGAINA/B2-0 bits = "000"), centered around the internal common voltage (typ. 0.5 x AVDD). Usually the input signal is AC coupled using a capacitor. The cut-off frequency is $f_c = 1/(2\pi RC)$. The ADC output data format is 2's complement. The DC offset including the ADC's own DC offset is removed by the internal HPF ($f_c=3.4\text{Hz}$ @ HPFA/B1-0 bits = "00", $f_s=44.1\text{kHz}$). The AK5703 can accept input voltages from VSS1 to AVDD.

CONTROL SEQUENCE

■ Clock Set up

When any circuits of the AK5703 are powered-up, the clocks must be supplied.

1. PLL Master Mode

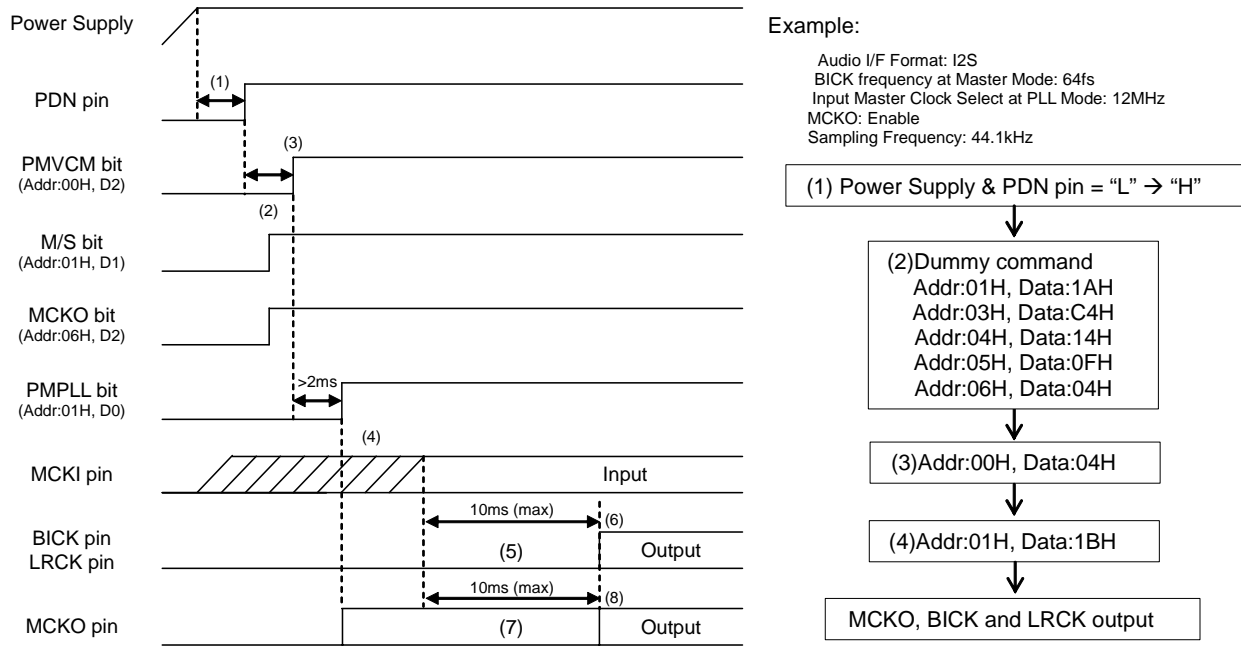

Figure 52. Clock Set Up Sequence (1)

< Example >

- (1) After Power Up, PDN pin "L" → "H".
 "L" time of 1μs or more is needed to reset the AK5703.
- (2) Dummy Command must be executed before control registers are set. M/S, PLL3-0, DIF1-0, FS3-0, PS1-0, BCKO and MCKO bits must be set during this period.
 In case of using MCKO output: MCKO bit = "1"
 In case of not using MCKO output: MCKO bit = "0"
- (3) Power Up VCOM: PMVCM bit = "0" → "1"
 VCOM must first be powered-up before operating other blocks. Rise-up time of the VCOM pin is 2ms (max) when the capacitance of an external capacitor is 1μF ±50%.
- (4) PLL starts after PMPLL bit changes from "0" to "1" and MCKI is supplied from an external source. PLL lock time is 10ms (max).
- (5) BICK pin and LRCK pin output "L" during this period.
- (6) The AK5703 starts outputting LRCK and BICK clocks after the PLL becomes stable. Then normal operation starts.
- (7) The invalid frequency is output from the MCKO pin during this period if MCKO bit = "1".
- (8) The normal clock is output from the MCKO pin after the PLL is locked if MCKO bit = "1".

2. PLL Slave Mode (BICK pin)

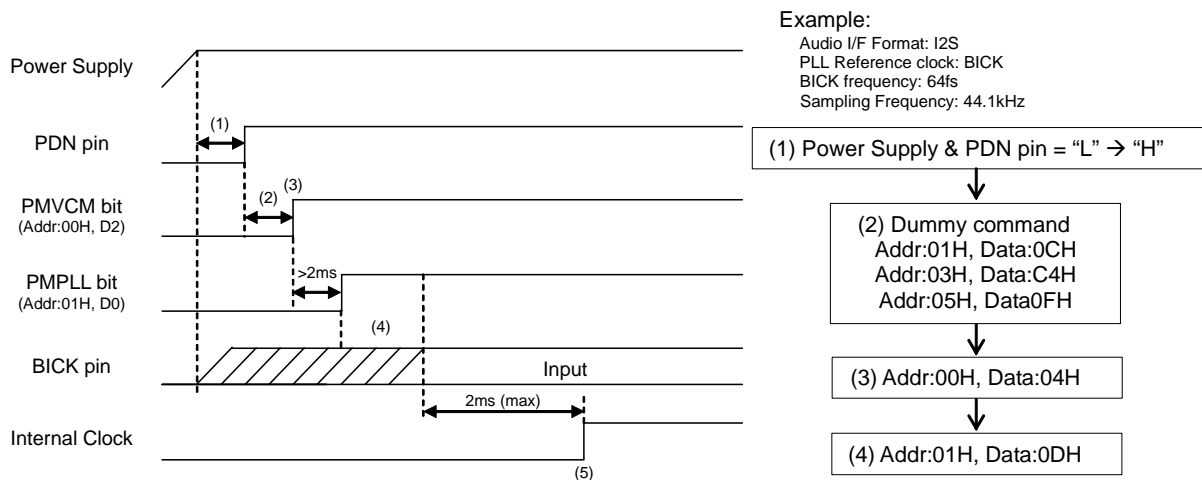
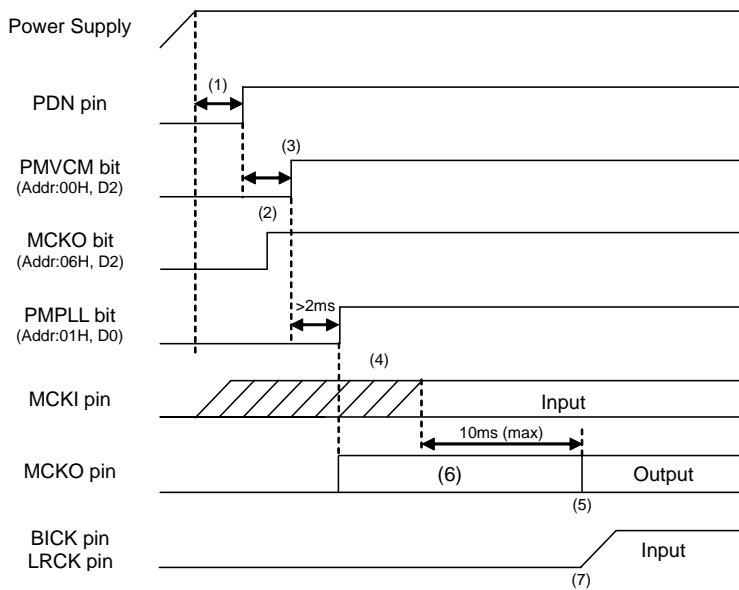

Figure 53. Clock Set Up Sequence (2)

<Example>

- (1) After Power Up: PDN pin "L" → "H"
 "L" time of 1μs or more is needed to reset the AK5703.
- (2) Dummy Command must be executed before control registers are set. PLL3-0, DIF1-0 and FS3-0 bits must be set during this period.
- (3) Power Up VCOM: PMVCM bit = "0" → "1"
 VCOM must first be powered-up before operating other blocks. Rise-up time of the VCOM pin is 2ms (max) when the capacitance of an external capacitor is 1μF ±50%.
- (4) PLL starts after the PMPLL bit changes from "0" to "1" and PLL reference clock (BICK pin) is supplied. PLL lock time is 2ms (max).
- (5) Normal operation starts after that the PLL is locked.

3. PLL Slave Mode (MCKI pin)



Example:

Audio I/F Format: I2S
 Input Master Clock Select at PLL Mode: 12MHz
 MCKO: Enable
 Sampling Frequency: 44.1kHz

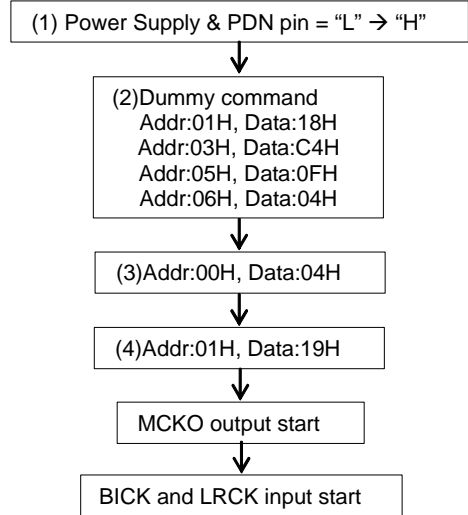

Figure 54. Clock Set Up Sequence (3)

<Example>

- (1) After Power up: PDN pin "L" → "H"
 "L" time of 1μs or more is needed reset the AK5703.
- (2) After Dummy Command input, PLL3-0, DIF1-0, FS3-0, PS1-0 and MCKO bits must be set during this period.
- (3) Power Up VCOM: PMVCM bit = "0" → "1"
 VCOM must first be powered-up before operating other blocks. Rise-up time of the VCOM pin is 2ms (max) when the capacitance of an external capacitor is 1μF ±50%.
- (4) PLL starts after the PMPLL bit changes from "0" to "1" and PLL reference clock (MCKI pin) is supplied. PLL lock time is 10ms (max).
- (5) The normal clock is output from the MCKO pin after the PLL is locked.
- (6) The invalid frequency is output from the MCKO pin during this period.
- (7) BICK and LRCK clocks must be synchronized with MCKO clock.

4. EXT Slave Mode

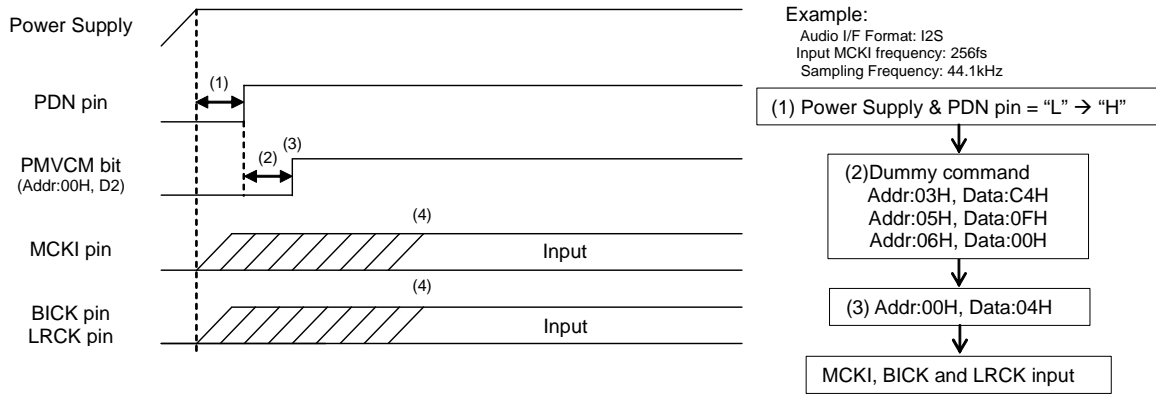

Figure 55. Clock Set Up Sequence (4)

<Example>

- (1) After power Up: PDN pin "L" → "H"
 "L" time of 1μs or more is needed to reset the AK5703.
- (2) After Dummy Command input, DIF1-0, FS3-0 and CM1-0 bits must be set during this period.
- (3) Power Up VCOM: PMVCM bit = "0" → "1"
 VCOM must first be powered-up before the other block operates. Rise-up time of the VCOM pin is 2ms (max) when the capacitance of an external capacitor is 1μF ±50%.
- (4) Normal operation starts after the MCKI, LRCK and BICK are supplied.

5. EXT Master Mode

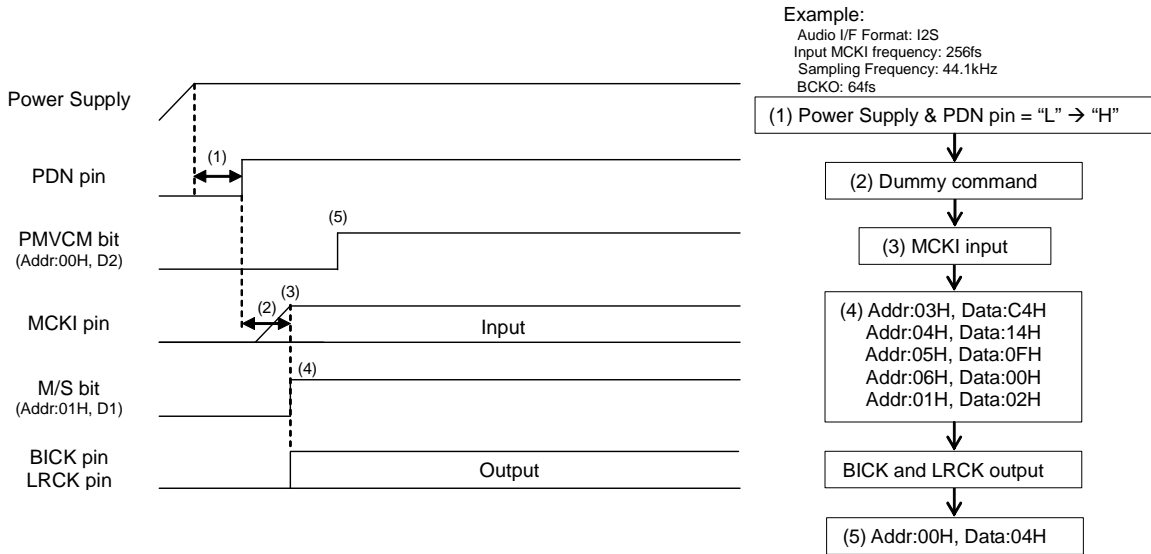
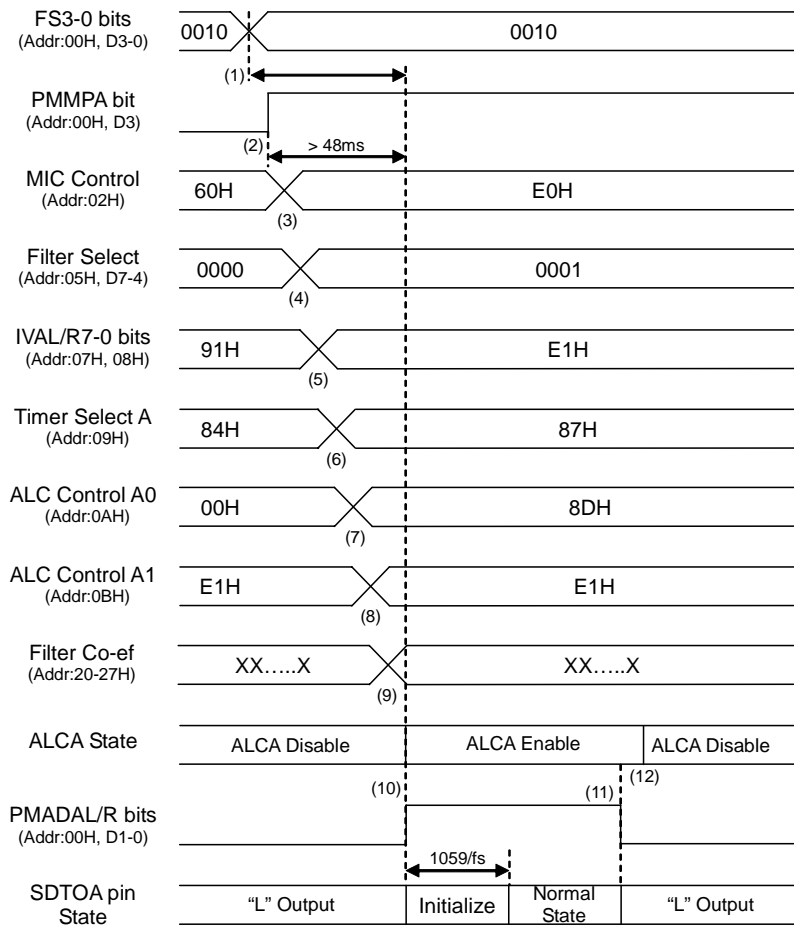

Figure 56. Clock Set Up Sequence (5)

<Example>

- (1) After power Up: PDN pin "L" → "H"
 "L" time of 1μs or more is needed to reset the AK5703.
- (2) Dummy Command must be input during this period.
- (3) MCKI is supplied.
- (4) After DIF1-0, FS3-0, BCKO1-0 and CM1-0 bits are set. M/S bit should be set to "1".
 Then LRCK and BICK are output.
- (5) Power Up VCOM: PMVCM bit = "0" → "1"
 VCOM must first be powered-up before the other block operates. Rise-up time of the VCOM pin is 2ms (max) when the capacitance of an external capacitor is 1μF ±50%.

■ Microphone Input Recording (Stereo)



Example:

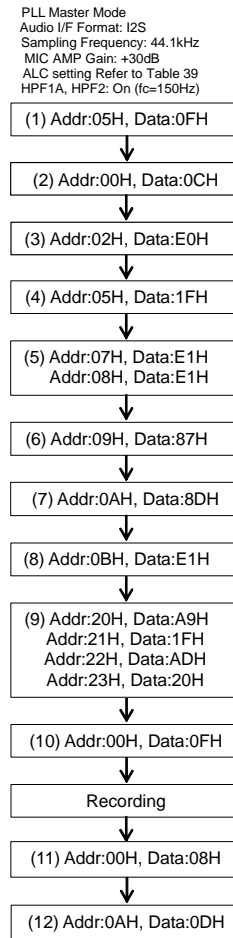

Figure 57. Microphone Input Recording Sequence (LIN1/RIN1 → ADCA → ALCA → Audio I/F → SDTOA)

<Example>

This sequence is an example of ALC setting at fs=44.1kHz. For changing the parameter of ALC, please refer to “Example of registers set-up sequence of ALC Operation”.

At first, clocks should be supplied according to “Clock Set Up” sequence.

- (1) Set up the sampling frequency (FS3-0 bits). When the AK5703 is in PLL mode, ADC of (10) must be powered-up in consideration of PLL lock time after the sampling frequency is changed.
- (2) Power up Microphone Power Supply A: PMMPA bit = “1”
Power-up time of Microphone Power is 48ms (max).
- (3) Set up HPF1A ON, Microphone Gain and Microphone Inputs (Addr = 02H)
- (4) Set up HPF2A and LPFA ON/OFF
- (5) Set up IVOL value of ALCA (Addr = 07H, 08H)
- (6) Set up the Timer of ALCA (Addr = 09H)
- (7) Set up the LMTHA1-0, RGAINA2-0, ALCEQN, ALCA bits (Addr = 0AH)
- (8) Set up IREF of ALCA (Addr = 0BH)
- (9) Set up Coefficient of HPF2A and LPFA (Addr: 20H ~ 27H)
- (10) Power up ADC: PMADAL = PMADAR bits = “0” → “1”
The initialization cycle time of ADC is 1059/fs=24ms @ fs=44.1kHz, ADRSTA1-0 bits = “00”. The ADC outputs “0” data during the initialization cycle. After the ALC bit is set to “1”, the ALCA operation starts from IVOL value of (5).
- (11) Power down ADC: PMADAL = PMADAR bits = “1” → “0”
- (12) ALCA Disable: ALCA bit = “1” → “0”

■ Stop of Clock

1. PLL Master Mode

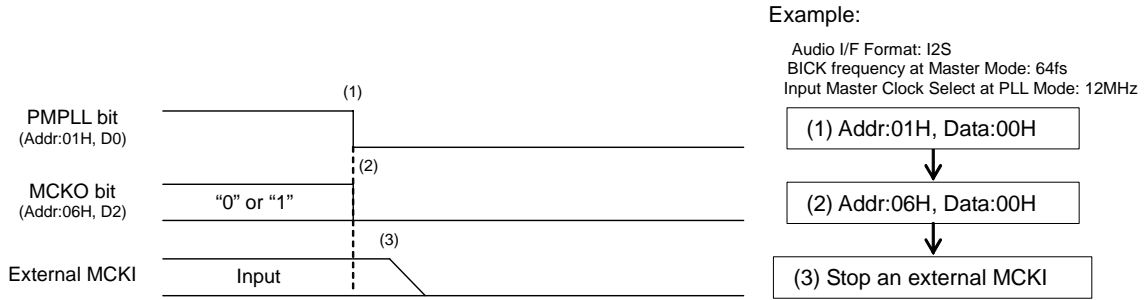

Figure 58. Clock Stopping Sequence (1)

<Example>

- (1) Power down PLL: PMPLL bit = "1" → "0"
- (2) Stop MCKO output: MCKO bit = "1" → "0"
- (3) Stop the external master clock.

2. PLL Slave Mode (BICK pin)

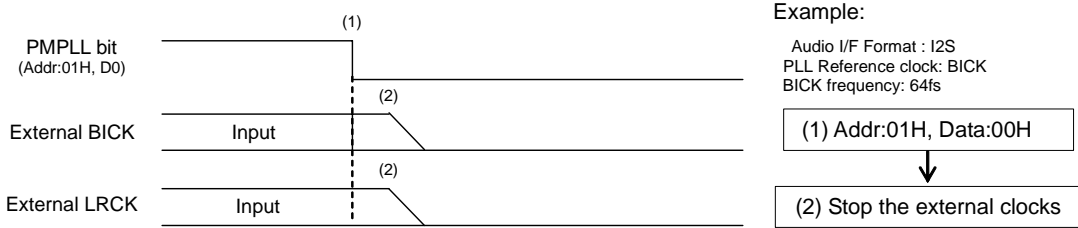

Figure 59. Clock Stopping Sequence (2)

<Example>

- (1) Power down PLL: PMPLL bit = "1" → "0"
- (2) Stop the external BICK and LRCK clocks.

3. PLL Salve Mode (MCKI pin)

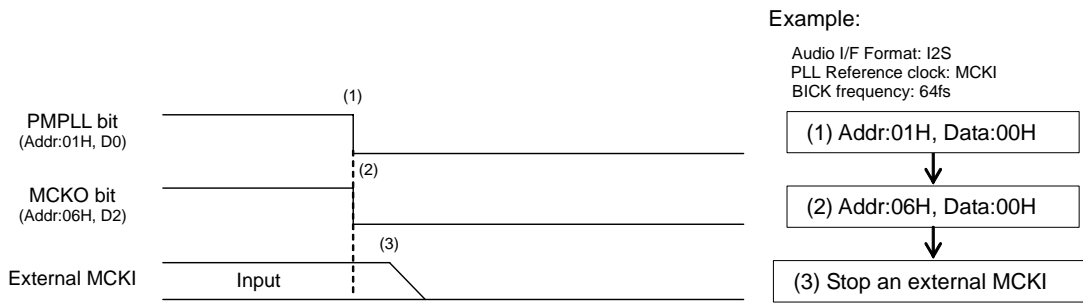

Figure 60. Clock Stopping Sequence (3)

<Example>

- (1) Power down PLL: PMPLL bit = “1” → “0”
- (2) Stop MCKO output: MCKO bit = “1” → “0”
- (3) Stop the external master clock.

4. EXT Slave Mode

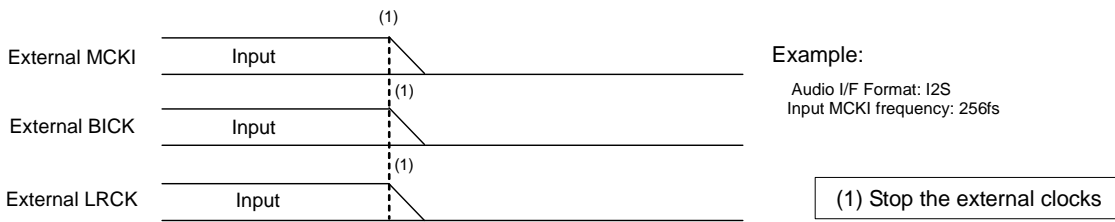

Figure 61. Clock Stopping Sequence (4)

<Example>

- (1) Stop the external MCKI, BICK and LRCK clocks.

■ Power Down

Power supply current can not be shut down by stopping clocks and setting PMVCM bit = “0”. Power supply current can be shut down (typ. 1μA) by stopping clocks and setting the PDN pin = “L”. When the PDN pin = “L”, all registers are initialized.

PACKAGE

28pin QFN

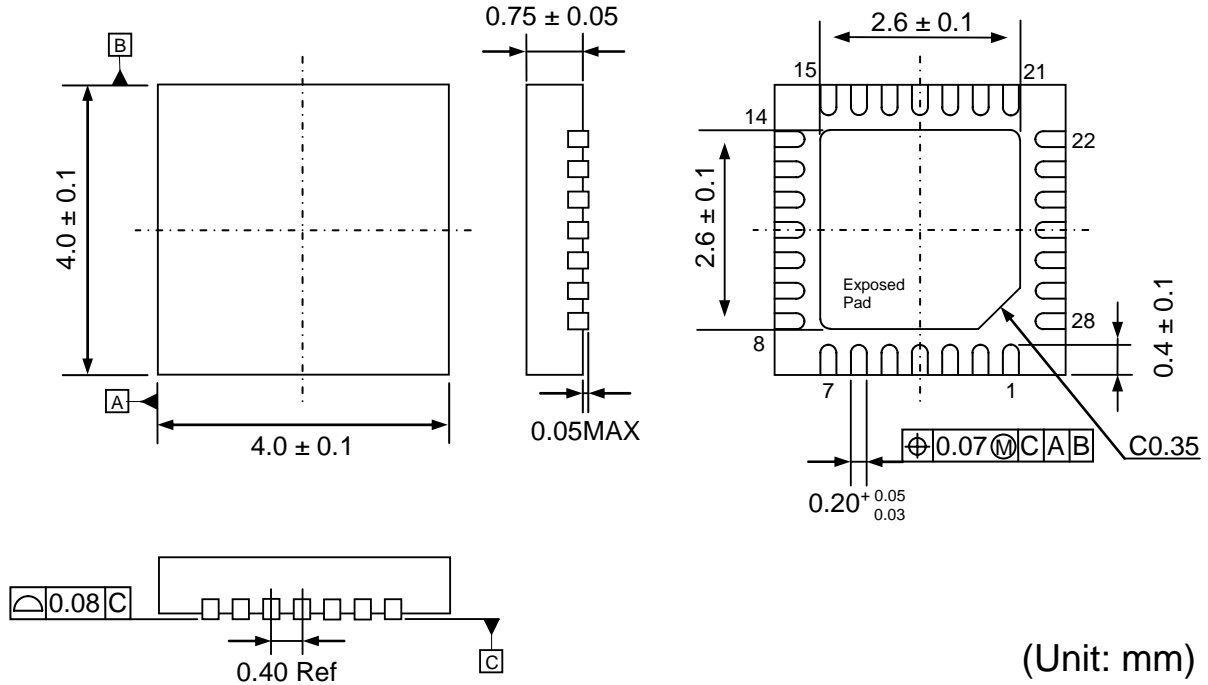

Note: The exposed pad on the bottom surface of the package must be open or connected to the ground.

■ Material & Lead finish

- Package molding compound: Epoxy Resin, Halogen (Br and Cl) free
- Lead frame material: Cu Alloy
- Lead frame surface treatment: Solder (Pb free) plate

MARKING

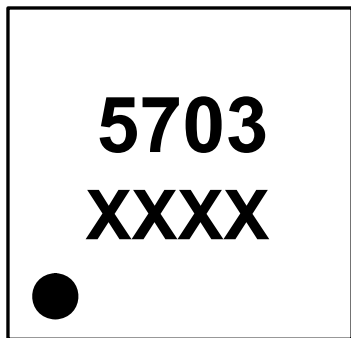

1

XXXX: Date code (4 digit)
Pin #1 indication

REVISION HISTORY

Date (Y/M/D)	Revision	Reason	Page/Line	Contents
13/05/08	00	First Edition		

————— IMPORTANT NOTICE —————

0. Asahi Kasei Microdevices Corporation (“AKM”) reserves the right to make changes to the information contained in this document without notice. When you consider any use or application of AKM product stipulated in this document (“Product”), please make inquiries the sales office of AKM or authorized distributors as to current status of the Products.
1. All information included in this document are provided only to illustrate the operation and application examples of AKM Products. AKM neither makes warranties or representations with respect to the accuracy or completeness of the information contained in this document nor grants any license to any intellectual property rights or any other rights of AKM or any third party with respect to the information in this document. You are fully responsible for use of such information contained in this document in your product design or applications. **AKM ASSUMES NO LIABILITY FOR ANY LOSSES INCURRED BY YOU OR THIRD PARTIES ARISING FROM THE USE OF SUCH INFORMATION IN YOUR PRODUCT DESIGN OR APPLICATIONS.**
2. The Product is neither intended nor warranted for use in equipment or systems that require extraordinarily high levels of quality and/or reliability and/or a malfunction or failure of which may cause loss of human life, bodily injury, serious property damage or serious public impact, including but not limited to, equipment used in nuclear facilities, equipment used in the aerospace industry, medical equipment, equipment used for automobiles, trains, ships and other transportation, traffic signaling equipment, equipment used to control combustions or explosions, safety devices, elevators and escalators, devices related to electric power, and equipment used in finance-related fields. Do not use Product for the above use unless specifically agreed by AKM in writing.
3. Though AKM works continually to improve the Product’s quality and reliability, you are responsible for complying with safety standards and for providing adequate designs and safeguards for your hardware, software and systems which minimize risk and avoid situations in which a malfunction or failure of the Product could cause loss of human life, bodily injury or damage to property, including data loss or corruption.
4. Do not use or otherwise make available the Product or related technology or any information contained in this document for any military purposes, including without limitation, for the design, development, use, stockpiling or manufacturing of nuclear, chemical, or biological weapons or missile technology products (mass destruction weapons). When exporting the Products or related technology or any information contained in this document, you should comply with the applicable export control laws and regulations and follow the procedures required by such laws and regulations. The Products and related technology may not be used for or incorporated into any products or systems whose manufacture, use, or sale is prohibited under any applicable domestic or foreign laws or regulations.
5. Please contact AKM sales representative for details as to environmental matters such as the RoHS compatibility of the Product. Please use the Product in compliance with all applicable laws and regulations that regulate the inclusion or use of controlled substances, including without limitation, the EU RoHS Directive. AKM assumes no liability for damages or losses occurring as a result of noncompliance with applicable laws and regulations.
6. Resale of the Product with provisions different from the statement and/or technical features set forth in this document shall immediately void any warranty granted by AKM for the Product and shall not create or extend in any manner whatsoever, any liability of AKM.
7. This document may not be reproduced or duplicated, in any form, in whole or in part, without prior written consent of AKM.