

MONOLITHIC 8-BIT PROGRAMMABLE DELAY LINE (SERIES 3D7438)

Super-Fine Resolution



FEATURES

- All-silicon, low-power CMOS technology
- TTL/CMOS compatible inputs and outputs
- Vapor phase, IR and wave solderable
- Leading- and trailing-edge accuracy
- Programmable via serial or parallel interface
- **Increment range:** 50ps through 250ps
- **Delay tolerance:** 0.5% (See Table 1)
- **Supply current:** 3mA typical
- **Temperature stability:** $\pm 1.5\%$ max (-40C to 85C)
- **Vdd stability:** $\pm 0.5\%$ max (4.75V to 5.25V)



PACKAGES

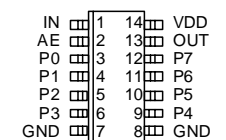
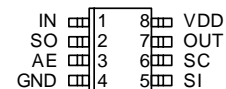
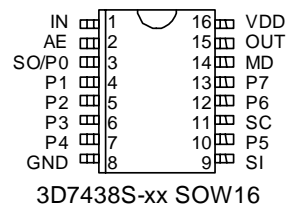

For mechanical dimensions, click [here](#).
For package marking details, click [here](#).

FUNCTIONAL DESCRIPTION

The 3D7438 device is a versatile 8-bit programmable monolithic delay line. The input (IN) is reproduced at the output (OUT) without inversion, shifted in time as per the user selection. Delay values, programmed either via the serial or parallel interface, can be varied over 255 equal steps according to the formula:

$$T_{i,nom} = T_{inh} + i * T_{inc}$$

where i is the programmed address, T_{inc} is the delay increment (equal to the device dash number), and T_{inh} is the inherent (address zero) delay. The device features both rising- and falling-edge accuracy.

The all-CMOS 3D7438 integrated circuit has been designed as a reliable, economic alternative to hybrid TTL programmable delay lines. It is offered in a standard surface mount 16-pin SOL. An 8-pin SOIC package is available for applications where the parallel interface is not needed. Similarly, a 14-pin SOIC is offered for applications where the serial interface is not needed.

PIN DESCRIPTIONS

| | |
|-------|---------------------|
| IN | Signal Input |
| OUT | Signal Output |
| MD | Mode Select |
| AE | Address Enable |
| P0-P7 | Parallel Data Input |
| SC | Serial Clock |
| SI | Serial Data Input |
| SO | Serial Data Output |
| VDD | +5 Volts |
| GND | Ground |

TABLE 1: PART NUMBER SPECIFICATIONS

| PART NUMBER | DELAYS AND TOLERANCES | | | INPUT RESTRICTIONS | | | |
|-------------|-----------------------|------------------|-----------------|--------------------|---------------------|----------------------|------------------------|
| | Inherent Delay (ns) | Delay Range (ns) | Delay Step (ps) | Max Freq (Addr=0) | Max Freq (Addr=255) | Min P.Width (Addr=0) | Min P.Width (Addr=255) |
| 3D7438x-50 | 7.0 \pm 0.5 | 12.750 \pm .05 | 50 \pm 25 | 150 MHz | 98 MHz | 3.3 ns | 5.1 ns |
| 3D7438x-60 | 7.0 \pm 0.5 | 15.300 \pm .06 | 60 \pm 30 | 150 MHz | 82 MHz | 3.3 ns | 6.1 ns |
| 3D7438x-75 | 7.0 \pm 0.5 | 19.125 \pm .08 | 75 \pm 38 | 150 MHz | 65 MHz | 3.3 ns | 7.6 ns |
| 3D7438x-80 | 7.0 \pm 0.5 | 20.400 \pm .08 | 80 \pm 40 | 150 MHz | 61 MHz | 3.3 ns | 8.1 ns |
| 3D7438x-100 | 7.0 \pm 0.5 | 25.500 \pm .10 | 100 \pm 50 | 150 MHz | 49 MHz | 3.3 ns | 10.0 ns |
| 3D7438x-125 | 7.0 \pm 0.5 | 31.875 \pm .13 | 125 \pm 63 | 150 MHz | 39 MHz | 3.3 ns | 12.7 ns |
| 3D7438x-150 | 7.0 \pm 0.5 | 38.250 \pm .15 | 150 \pm 75 | 150 MHz | 32 MHz | 3.3 ns | 15.3 ns |
| 3D7438x-200 | 7.0 \pm 0.5 | 51.000 \pm .20 | 200 \pm 100 | 150 MHz | 24 MHz | 3.3 ns | 20.4 ns |
| 3D7438x-250 | 7.0 \pm 0.5 | 63.750 \pm .25 | 250 \pm 125 | 150 MHz | 19 MHz | 3.3 ns | 25.5 ns |

NOTES: Replace the 'x' in the part number with D, S or Z, depending on choice of package.
Any dash number between 50 and 250 not shown is also available as standard.
See application notes section for more details

©2010 Data Delay Devices

APPLICATION NOTES

GENERAL INFORMATION

The 8-bit programmable 3D7438 delay line architecture is comprised of a sequence of five identical delay cells connected in series, all of which are controlled by a common current. This current, in turn, is controlled by the user-selected programming data (the address). The delay cells produce at their output a replica of the signal present at the input, shifted in time. The change in delay from one address setting to the next is called the *increment*, or LSB. It is nominally equal to the device dash number. The minimum delay, achieved by setting the address to zero, is called the *inherent delay*.

For best performance, it is essential that the power supply pin be adequately bypassed and filtered. In addition, the power bus should be of as low an impedance construction as possible. Power planes are preferred. Also, signal traces should be kept as short as possible.

DELAY ACCURACY

There are a number of ways of characterizing the delay accuracy of a programmable line. The first is the *differential nonlinearity* (DNL), also referred to as the increment error. It is defined as the deviation of the increment at a given address from its nominal value. For all dash numbers, the DNL is within 0.5 LSB at every address (see Table 1: Delay Step).

The *integrated nonlinearity* (INL) is determined by first constructing the least-squares best fit straight line through the delay-versus-address data. The INL is then the deviation of a given delay from this line. For all dash numbers, the INL is within 1.0 LSB at every address.

The *relative error* is defined as follows:

$$e_{rel} = (T_i - T_0) - i * T_{inc}$$

where i is the address, T_i is the measured delay at the i 'th address, T_0 is the measured inherent delay, and T_{inc} is the nominal increment. It is very similar to the INL, but simpler to calculate. For all dash numbers, the relative error is less than 1.0 LSB at every address (see Table 1: Delay Range).

The *absolute error* is defined as follows:

$$e_{abs} = T_i - (T_{inh} + i * T_{inc})$$

where T_{inh} is the nominal inherent delay. The absolute error is limited to 1.5 LSB or 1.0 ns, whichever is greater, at every address.

The *inherent delay error* is the deviation of the inherent delay from its nominal value. For all dash numbers, it is limited to 0.5 ns.

DELAY STABILITY

The delay of CMOS integrated circuits is strongly dependent on power supply and temperature. The 3D7438 utilizes novel compensation circuitry to minimize the delay variations induced by fluctuations in power supply and/or temperature.

The 3D7438 is designed to be most stable at the maximum address setting (255). At this operating condition, the thermal coefficient of the absolute delay is limited to ± 250 PPM/C, which is equivalent to a variation, over the -40C to 85C operating range, of $\pm 1.5\%$ from the room-temperature delay. At smaller address settings the thermal coefficient will be somewhat larger.

At the maximum address, the power supply sensitivity of the absolute delay is $\pm 0.5\%$ over the 4.75V to 5.25V operating range, with respect to the delay at the nominal 5.0V power supply. At smaller address settings the sensitivity will be somewhat larger.

INPUT SIGNAL CHARACTERISTICS

The maximum input frequency and minimum input pulse width are both limited by the device. Exceeding either limit will cause the signal to be blocked by the line. Furthermore, for a given device, these limitations vary with the user-specified address. The relationships are:

$$F_{Max} = 1250 / (i * T_{inc})$$

$$PW_{Min} = 0.4 * (i * T_{inc}),$$

where F_{Max} is in MHz, and PW_{Min} & T_{inc} are in ns. These relationships break down for small delays: F_{Max} can never be greater than 150 MHz, and PW_{Min} can never be smaller than 3.3 ns.

PROGRAMMING INTERFACE

Figure 1 illustrates the main functional blocks of the 3D7438 delay program interface. Since the 3D7438 is a CMOS design, all unused input pins must be returned to well defined logic levels, VDD or Ground.

APPLICATION NOTES (CONT'D)

TRANSPARENT PARALLEL MODE (MD = 1, AE = 1)

The eight program pins P0 - P7 directly control the output delay. A change on one or more of the program pins will be reflected on the output delay after a time t_{PDV} , as shown in Figure 2. A register is required if the programming data is bused.

LATCHED PARALLEL MODE (MD = 1, AE PULSED)

The eight program pins P0 - P7 are loaded by the falling edge of the Enable pulse, as shown in Figure 3. After each change in delay value, a settling time t_{EDV} is required before the input is accurately delayed.

SERIAL MODE (MD = 0)

While observing data setup (t_{DSC}) and data hold (t_{DHC}) requirements, timing data is loaded in MSB-to-LSB order by the rising edge of the clock (SC) while the enable (AE) is high, as shown in Figure 4. The falling edge of the enable (AE) activates the new delay value which is reflected at the output after a settling time t_{EDV} . As data is shifted into the serial data input (SI), the previous contents of the 8-bit input register are shifted out of the serial output port pin (SO) in MSB-to-LSB

order, thus allowing cascading of multiple devices by connecting the serial output pin (SO) of the preceding device to the serial data input pin (SI) of the succeeding device, as illustrated in Figure 5. The total number of serial data bits in a cascade configuration must be eight times the number of units, and each group of eight bits must be transmitted in MSB-to-LSB order.

To initiate a serial read, enable (AE) is driven high. After a time t_{EQV} , bit 7 (MSB) is valid at the serial output port pin (SO). On the first rising edge of the serial clock (SC), bit 7 is loaded with the value present at the serial data input pin (SI), while bit 6 is presented at the serial output pin (SO). To retrieve the remaining bits seven more rising edges must be generated on the serial clock line. The read operation is destructive. Therefore, if it is desired that the original delay setting remain unchanged, the read data must be written back to the device(s) before the enable (AE) pin is brought low.

The SO pin, if unused, must be allowed to float if the device is configured in the serial programming mode.

The serial mode is the *only* mode available on the 8-pin version of the 3D7438, and this mode is *unavailable* on the 14-pin version of the 3D7438.

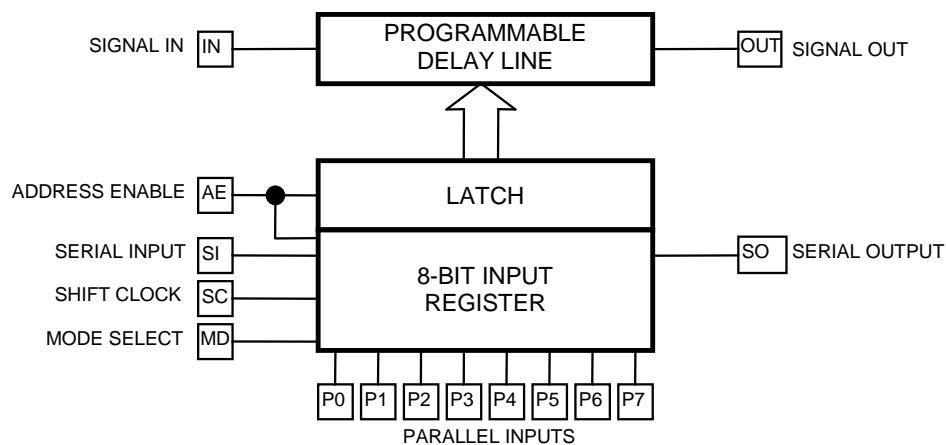

Figure 1: Functional block diagram

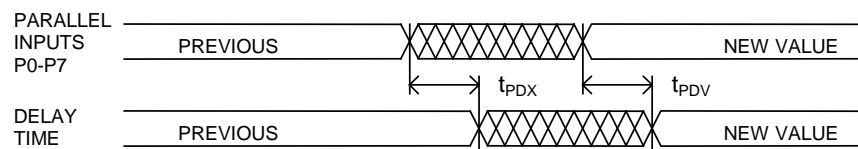

Figure 2: Non-latched parallel mode (MD=1, AE=1)

APPLICATION NOTES (CONT'D)

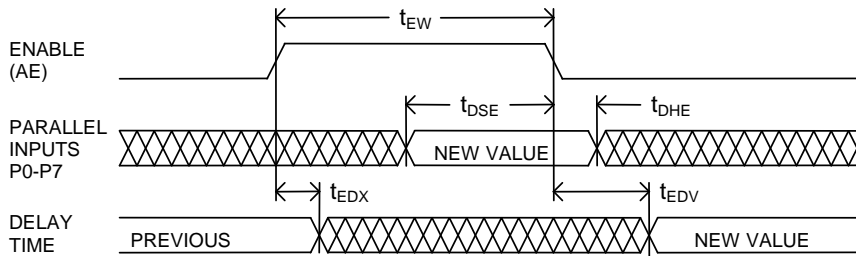

Figure 3: Latched parallel mode (MD=1)

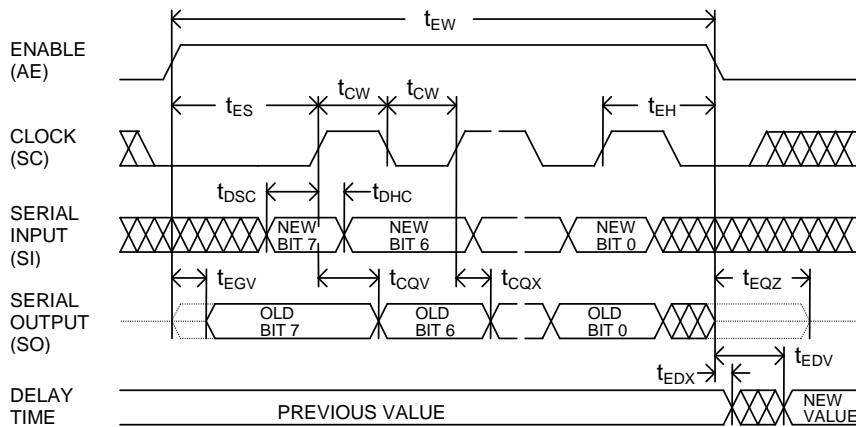

Figure 4: Serial mode (MD=0)

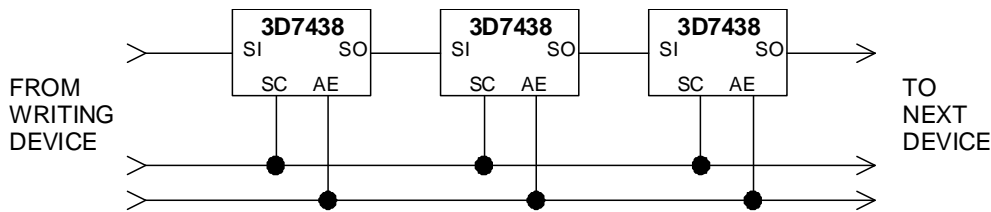

Figure 5: Cascading Multiple Devices

TABLE 2: DELAY VS. PROGRAMMED ADDRESS

| PARALLEL SERIAL | PROGRAMMED ADDRESS | | | | | | | | NOMINAL DELAY (NS) PER 3D7438 DASH NUMBER | | | | | | |
|--------------------|--------------------|----|----|----|----|----|----|----|--|--------|--------|--------|--------|--------|--------|
| | P7 | P6 | P5 | P4 | P3 | P2 | P1 | P0 | -50 | -75 | -100 | -125 | -150 | -200 | -250 |
| STEP 0 | 0 | 0 | 0 | 0 | 0 | 0 | 0 | 0 | 7.000 | 7.000 | 7.000 | 7.000 | 7.000 | 7.000 | 7.000 |
| STEP 1 | 0 | 0 | 0 | 0 | 0 | 0 | 0 | 1 | 7.050 | 7.075 | 7.100 | 7.125 | 7.150 | 7.200 | 7.250 |
| STEP 2 | 0 | 0 | 0 | 0 | 0 | 0 | 1 | 0 | 7.100 | 7.150 | 7.200 | 7.250 | 7.300 | 7.400 | 7.500 |
| STEP 3 | 0 | 0 | 0 | 0 | 0 | 0 | 1 | 1 | 7.150 | 7.225 | 7.300 | 7.375 | 7.450 | 7.600 | 7.750 |
| STEP 4 | 0 | 0 | 0 | 0 | 0 | 1 | 0 | 0 | 7.200 | 7.300 | 7.400 | 7.500 | 7.600 | 7.800 | 8.000 |
| STEP 5 | 0 | 0 | 0 | 0 | 0 | 1 | 0 | 1 | 7.250 | 7.375 | 7.500 | 7.625 | 7.750 | 8.000 | 8.250 |
| STEP 253 | 1 | 1 | 1 | 1 | 1 | 1 | 0 | 1 | 19.650 | 25.975 | 32.300 | 38.625 | 44.950 | 57.600 | 70.250 |
| STEP 254 | 1 | 1 | 1 | 1 | 1 | 1 | 1 | 0 | 19.700 | 26.050 | 32.400 | 38.750 | 45.100 | 57.800 | 70.500 |
| STEP 255 | 1 | 1 | 1 | 1 | 1 | 1 | 1 | 1 | 19.750 | 26.125 | 32.500 | 38.875 | 45.250 | 58.000 | 70.750 |
| CHANGE | | | | | | | | | 12.750 | 19.125 | 25.500 | 31.875 | 38.250 | 51.000 | 63.750 |

DEVICE SPECIFICATIONS

TABLE 3: ABSOLUTE MAXIMUM RATINGS

| PARAMETER | SYMBOL | MIN | MAX | UNITS | NOTES |
|---------------------|------------|------|--------------|-------|--------|
| DC Supply Voltage | V_{DD} | -0.3 | 7.0 | V | |
| Input Pin Voltage | V_{IN} | -0.3 | $V_{DD}+0.3$ | V | |
| Input Pin Current | I_{IN} | -10 | 10 | mA | 25C |
| Storage Temperature | T_{STRG} | -55 | 150 | C | |
| Lead Temperature | T_{LEAD} | | 300 | C | 10 sec |

TABLE 4: DC ELECTRICAL CHARACTERISTICS

(-40C to 85C, 4.75V to 5.25V)

| PARAMETER | SYMBOL | MIN | TYP | MAX | UNITS | NOTES |
|---------------------------|---------------|-----|-------|------|---------|-------------------------------------|
| Static Supply Current* | I_{DD} | | 3.0 | 5.0 | mA | Addr = 128 |
| High Level Input Voltage | V_{IH} | 2.0 | | | V | |
| Low Level Input Voltage | V_{IL} | | | 0.8 | V | |
| High Level Input Current | I_{IH} | | | 1.0 | μ A | $V_{IH} = V_{DD}$ |
| Low Level Input Current | I_{IL} | | | 1.0 | μ A | $V_{IL} = 0V$ |
| High Level Output Current | I_{OH} | | -35.0 | -4.0 | mA | $V_{DD} = 4.75V$ $V_{OH} = 2.4V$ |
| Low Level Output Current | I_{OL} | 4.0 | 15.0 | | mA | $V_{DD} = 4.75V$ $V_{OL} = 0.4V$ |
| Output Rise & Fall Time | T_R & T_F | | 2.0 | 2.5 | ns | $C_{LD} = 5$ pf |

* $I_{DD}(\text{Dynamic}) = C_{LD} * V_{DD} * F$
 where: C_{LD} = Average capacitance load/line (pf)
 F = Input frequency (GHz)

Input Capacitance = 10 pf typical
 Output Load Capacitance (C_{LD}) = 25 pf max

TABLE 5: AC ELECTRICAL CHARACTERISTICS

(-40C to 85C, 4.75V to 5.25V)

| PARAMETER | SYMBOL | MIN | TYP | MAX | UNITS | NOTES |
|--|--------------------|-----|-----|-----|------------|-------------|
| Clock Frequency | f_C | | | 80 | MHz | |
| Enable Width | t_{EW} | 10 | | | ns | |
| Clock Width | t_{CW} | 10 | | | ns | |
| Data Setup to Clock | t_{DSC} | 10 | | | ns | |
| Data Hold from Clock | t_{DHC} | 3 | | | ns | |
| Data Setup to Enable | t_{DSE} | 10 | | | ns | |
| Data Hold from Enable | t_{DHE} | 3 | | | ns | |
| Enable to Serial Output Valid | t_{EQV} | | | 20 | ns | |
| Enable to Serial Output High-Z | t_{EQZ} | | | 20 | ns | |
| Clock to Serial Output Valid | t_{CQV} | | | 20 | ns | |
| Clock to Serial Output Invalid | t_{CQX} | 10 | | | ns | |
| Enable Setup to Clock | t_{ES} | 10 | | | ns | |
| Enable Hold from Clock | t_{EH} | 10 | | | ns | |
| Parallel Input Valid to Delay Valid | t_{PDV} | | 20 | 40 | ns | |
| Parallel Input Change to Delay Invalid | t_{PDX} | 0 | | | ns | |
| Enable to Delay Valid | t_{EDV} | | 35 | 45 | ns | |
| Enable to Delay Invalid | t_{EDX} | 0 | | | ns | |
| Input Pulse Width | t_{WI} | 40 | | | % of Delay | See Table 1 |
| Input Period | Period | 80 | | | % of Delay | See Table 1 |
| Input to Output Delay | t_{PLH}, t_{PHL} | | | | ns | See Table 2 |

SILICON DELAY LINE AUTOMATED TESTING

TEST CONDITIONS

INPUT:

Ambient Temperature: $25^{\circ}\text{C} \pm 3^{\circ}\text{C}$
Supply Voltage (Vcc): $5.0\text{V} \pm 0.1\text{V}$
Input Pulse: High = $3.0\text{V} \pm 0.1\text{V}$
 Low = $0.0\text{V} \pm 0.1\text{V}$
Source Impedance: 50Ω Max.
Rise/Fall Time: 3.0 ns Max. (measured between 0.6V and 2.4V)
Pulse Width: $\text{PW}_{\text{IN}} = 2 \times \text{Max Delay}$
Period: $\text{PER}_{\text{IN}} = 10 \times \text{Max Delay}$

OUTPUT:

R_{load}: $10\text{K}\Omega \pm 10\%$
C_{load}: $5\text{pf} \pm 10\%$
Threshold: 1.5V (Rising & Falling)

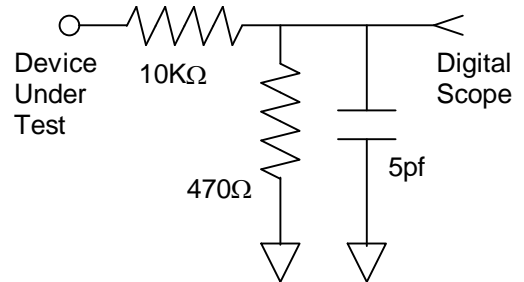

NOTE: The above conditions are for test only and do not in any way restrict the operation of the device.

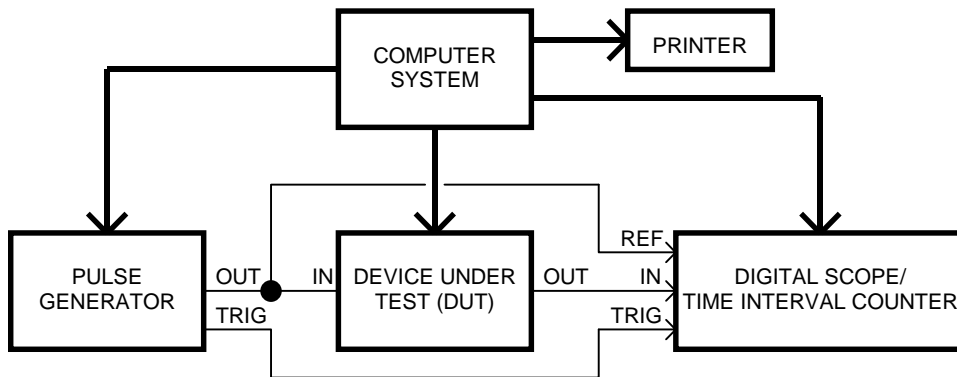

Figure 6: Test Setup

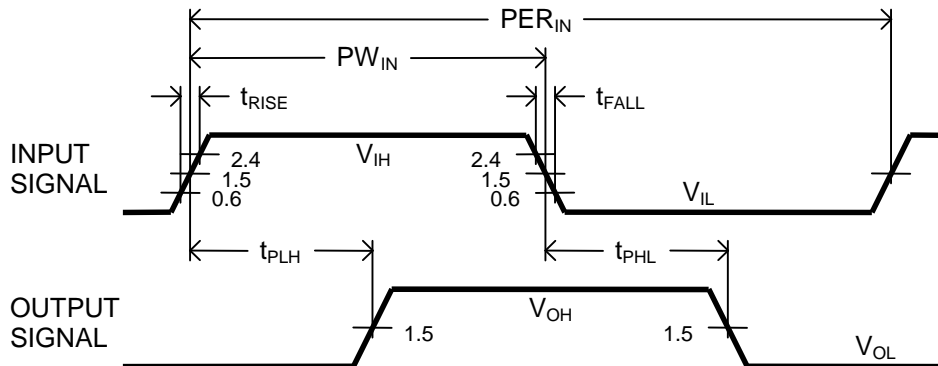

Figure 7: Timing Diagram