

DWC. NO.		291-910-0631G	
REV	DESCRIPTION	BY DATE	APPRO
F	ECN 2447		

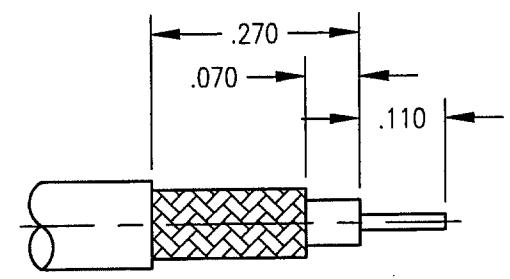
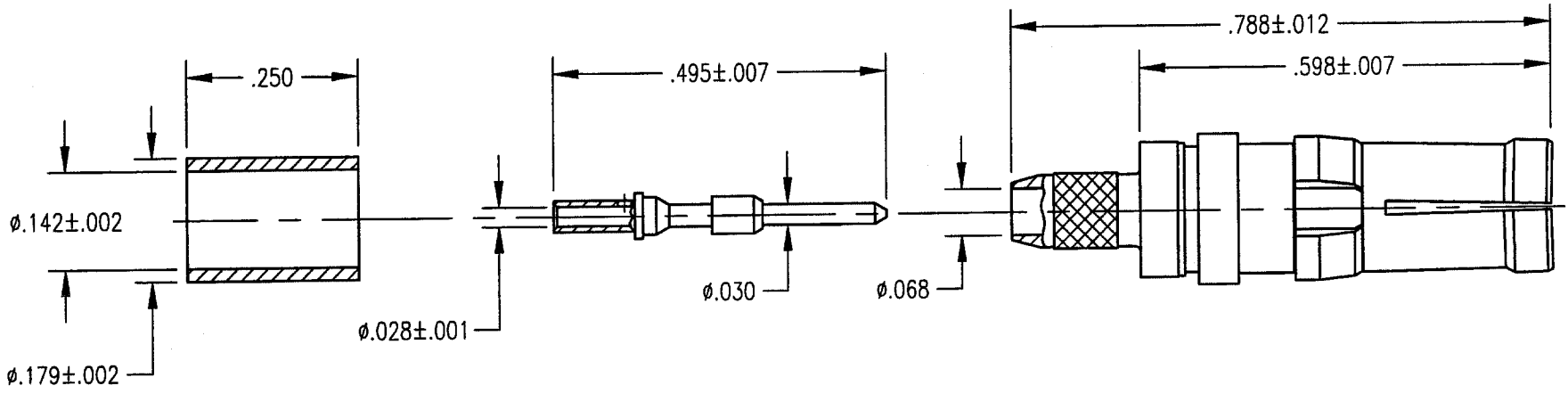

CABLE TRIMMING DIMENSIONS

NOTES:

- MATERIALS:  
 FRONT BODY AND CENTER CONTACT: BERYLLIUM COPPER PER ASTM B196  
 INSULATOR: TEFLON PER ASTM D1710  
 CLIP RING: BERYLLIUM COPPER PER ASTM B194  
 ALL OTHER METAL PARTS: BRASS PER ASTM B16
- FINISH:  
 BODY AND CONTACT: .000030 MIN. GOLD PER MIL-G-45204 OVER  
 .000050 MIN. NICKEL PER QQ-N-290  
 CLIP RING: .000100 MIN. NICKEL PER QQ-N-290 OVER  
 COPPER FLASH  
 FERRULE: .000005 MIN. GOLD PER MIL-G-45204 OVER  
 .000050 MIN. NICKEL PER QQ-N-290
- FOR USE WITH RG-316 DOUBLE SHIELDED CABLE OR EQUIVALENT.
- FOR CABLING PROCEDURES USE CAP 9-07 WITH DIMENSIONS SHOWN.

PER ASME Y14.5M-1994 UNLESS OTHERWISE SPECIFIED: DIMENSIONS ARE IN INCHES (MM) TOLERANCES: DECIMALS .XX ± .01/0.254 XXX ± .005/0.127 ANGLES ± 2° SCALE: 4:1				<b>Litton</b> <b>Winchester/Retconn</b> 400 Park Road Watertown, Connecticut 06795			
<b>CUSTOMER DRAWING</b>			TITLE RDM-HF STRAIGHT RECEPTACLE				
DRAWN	DATE	CHECKED	DATE	SMT.	OF	REV.	
JED	10/2/98	KJT	10/2/98	1	1	F	
APPROVED	DATE	APPROVED	DATE	A 291-910-0631G			
JMC	10/2/98	JMC	10/2/98				