

DASH NO.	M CODE	MADE FROM
----------	--------	-----------

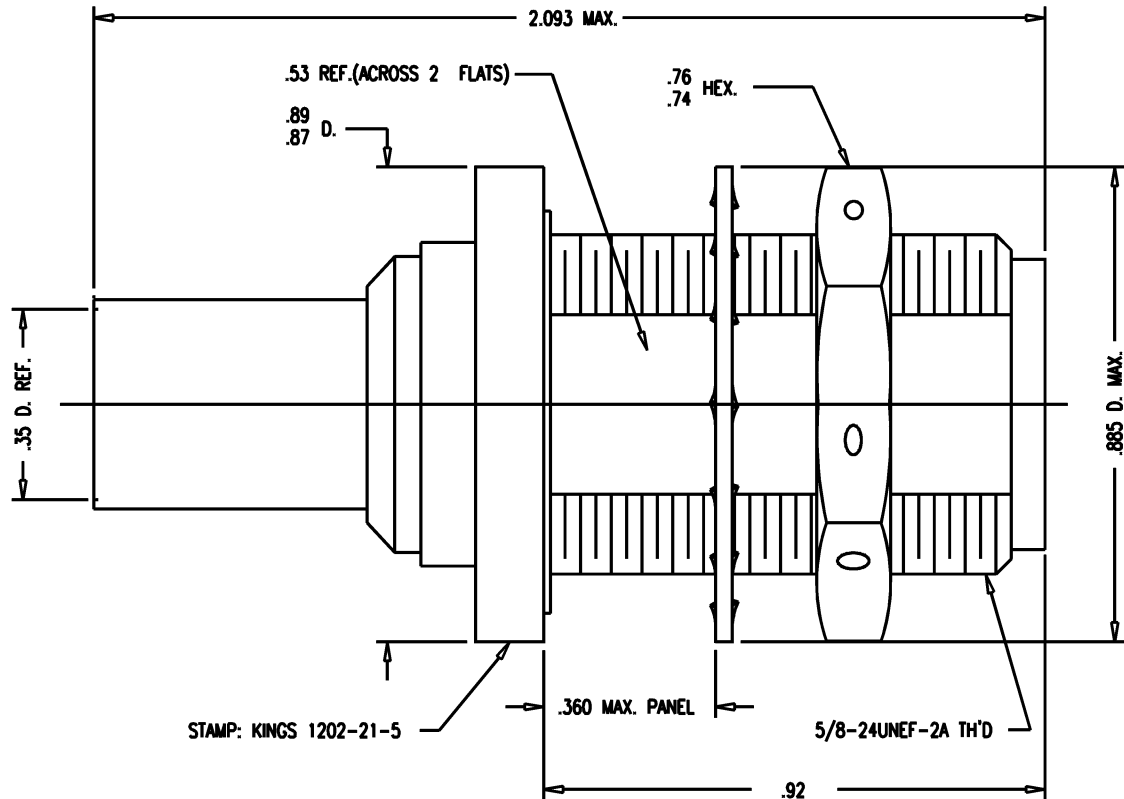

- NOTES:
- FOR USE WITH DOUGLAS D2348-2 CABLE.
 - FOR CABLING INSTRUCTIONS SEE CP-5402.
 - FOR CRIMPING USE DIE KTH-2012.
 - INTERFACE PER MIL-STD-348, FIG. 304-2.
 - CENTER CONTACT (1-534-7M9D) SUPPLIED UNASSEMBLED.
 - MARK PACKAGE: KINGS 1202-21-5 XX XX (DATE CODE)
DOUGLAS 500489-2
 - MATERIALS:
INSULATOR-TEFLON, ASTM-D-4894
LOCKWASHER-PHOS. BRONZE, ASTM-B-103
CENTER CONTACT-BER. COP., ASTM-B-196
K-GRIP SLEEVE-COM. BRONZE, ASTM-B-140
GASKET-SILICONE RUBBER, ZZ-R-765
ALL OTHER METAL PARTS-BRASS, ASTM-B16
 - FINISHES:
CENTER CONTACT-GOLD PLATE PER MIL-G-45204
ALL OTHER METAL PARTS-SILVER PLATE PER QQ-S-365
 - ELECTRICAL CHARACTERISTICS:
NOMINAL IMPEDANCE-50 OHMS
FREQUENCY RANGE-DC TO 11 GHZ
WORKING VOLTAGE-1000 VRMS

GSD

1202-21-5

REVISIONS	
ISSUE	CHANGES
0	ER 36810 KH 02/08/96
1	CN 36850 A CCT 02/28/96
2	CN 36978 C KH 05/20/96
3	CN 38941 E DCT 10/2/3

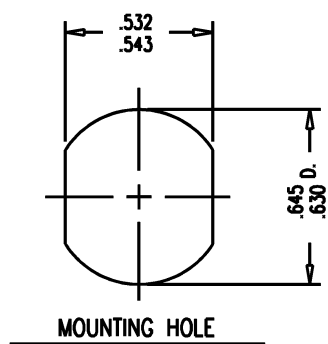

GSD

SCALE	4:1		
APPROX SURFACE AREA			
USED ON			
REF:	Mc D. D. AIRCRAFT # 500489-2 REV. A		
JACK, BULKHEAD, N			
DRAWN	KH	DATE	02/08/96
DESIGN	CT	DATE	02/09/96
APPR.		DATE	

KINGS
ELECTRONICS CO., INC.
ROCK HILL, SOUTH CAROLINA 29730

1202-21-5