



Solid State Devices, Inc.

14701 Firestone Blvd. * La Mirada, Ca 90638
 Phone: (562) 404-4474 * Fax: (562) 404-1773
 ssdi@ssdi-power.com * www.ssdi-power.com

SER30KB60 / SER30KE60 Series

**30 AMP 300-600 VOLT
 ULTRAFAST POWER
 SURFACE MOUNT RECTIFIER**

Designer's Data Sheet

Part Number / Ordering Information^{1/}

SER30

L Screening^{2/} = None
 TX = TX Level
 TXV = TXV Level
 S = S Level

 L Voltage
 L Configuration
 KB = without lead
 KE = with lead

- FEATURES:**
- Low Reverse Leakage
 - Low Forward Voltage Drop
 - Hermetically Sealed Power Surface Mount Package
 - TX, TXV, and Space Level Screening Available^{2/}

MAXIMUM RATINGS	Symbol	Value	Units	
Peak Repetitive Reverse Voltage and DC Blocking Voltage	SER30KE30, SER30KB30 SER30KE40, SER30KH40 SER30KE50, SER30KB50 SER30KE60, SER30KB60	V_{RRM} V_{RWM} V_R	300 400 500 600	Volts
Average Rectified Forward Current (Resistive Load, 60 Hz, Sine Wave, $T_A = 100^\circ\text{C}$)		I_O	30	Amps
Peak Surge Current (8.3 ms Pulse, Half Sine Wave, Superimposed on I_O , Allow Junction to Reach Equilibrium between Pulses, $T_A = 25^\circ\text{C}$)		I_{FSM}	400	Amps
Operating and Storage Temperature		T_{OP} & T_{stg}	-55 to +200	$^\circ\text{C}$
Maximum Thermal Resistance Junction to Case		$R_{\theta JC}$	1.2	$^\circ\text{C/W}$

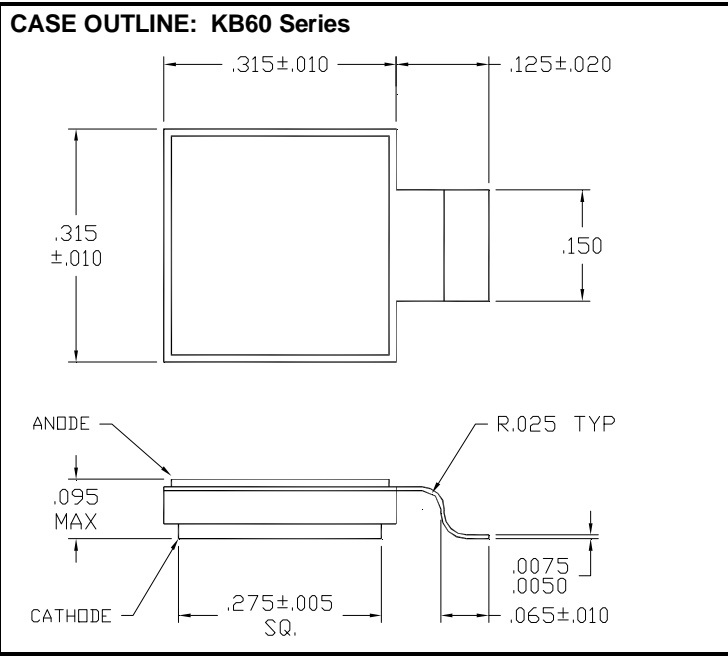
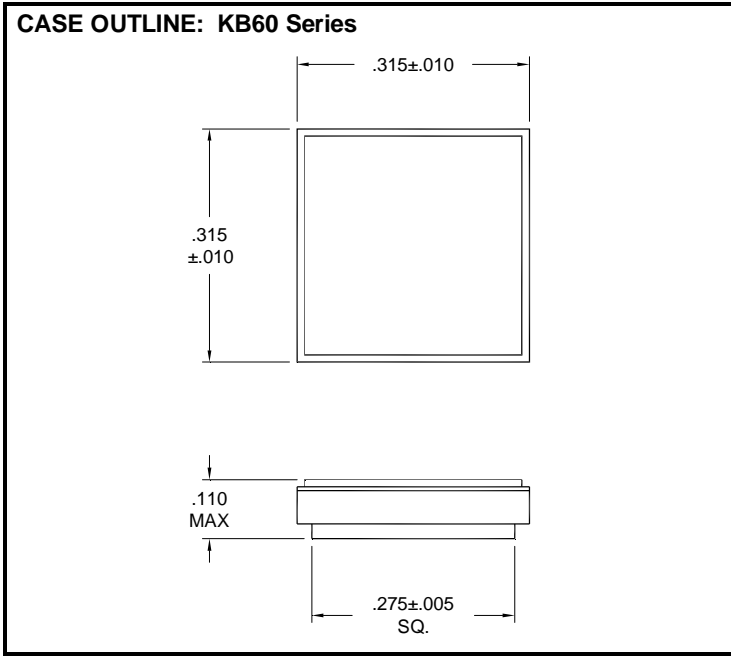

NOTE: All specifications are subject to change without notification. SCD's for these devices should be reviewed by SSDI prior to release.

DATA SHEET #: RC0128B

DOC



Solid State Devices, Inc.
 14701 Firestone Blvd. * La Mirada, Ca 90638
 Phone: (562) 404-4474 * Fax: (562) 404-1773
 ssdi@ssdi-power.com * www.ssdi-power.com

SER30KB60 / SER30KE60 Series

ELECTRICAL CHARACTERISTICS		Symbol	Typical	Maximum	Unit	
Instantaneous Forward Voltage Drop ($I_F = 5 \text{ A}$, 300 μsec Pulse)	$T_A = -55^\circ\text{C}$	V_{F1a}	1070	-	mV_{DC}	
	$T_A = 25^\circ\text{C}$	V_{F1b}	950	-		
	$T_A = 100^\circ\text{C}$	V_{F1c}	760	-		
	$T_A = 125^\circ\text{C}$	V_{F1d}	710	-		
	$T_A = 150^\circ\text{C}$	V_{F1e}	650	-		
Instantaneous Forward Voltage Drop ($I_F = 10 \text{ A}_{\text{DC}}$, 300 μsec Pulse)	$T_A = -55^\circ\text{C}$	V_{F2a}	1150	-	mV_{DC}	
	$T_A = 25^\circ\text{C}$	V_{F2b}	1050	1150		
	$T_A = 100^\circ\text{C}$	V_{F2c}	860	-		
	$T_A = 125^\circ\text{C}$	V_{F2d}	810	975		
	$T_A = 150^\circ\text{C}$	V_{F2e}	750	-		
Instantaneous Forward Voltage Drop ($I_F = 20 \text{ A}_{\text{DC}}$, $T_A = +125^\circ\text{C}$, 300 μsec Pulse)	$T_A = -55^\circ\text{C}$	V_{F3a}	1260	-	mV_{DC}	
	$T_A = 25^\circ\text{C}$	V_{F3b}	1170	-		
	$T_A = 100^\circ\text{C}$	V_{F3c}	1000	-		
	$T_A = 125^\circ\text{C}$	V_{F3d}	950	-		
	$T_A = 150^\circ\text{C}$	V_{F3e}	880	-		
Instantaneous Forward Voltage Drop ($I_F = 30 \text{ A}_{\text{DC}}$, $T_A = +125^\circ\text{C}$, 300 μsec Pulse)	$T_A = -55^\circ\text{C}$	V_{F4a}	1340	-	mV_{DC}	
	$T_A = 25^\circ\text{C}$	V_{F4b}	1260	1400		
	$T_A = 100^\circ\text{C}$	V_{F4c}	1100	-		
	$T_A = 125^\circ\text{C}$	V_{F4d}	1050	1250		
	$T_A = 150^\circ\text{C}$	V_{F4e}	990	-		
Instantaneous Forward Voltage Drop ($I_F = 50 \text{ A}_{\text{DC}}$, $T_A = +125^\circ\text{C}$, 300 μsec Pulse)	$T_A = -55^\circ\text{C}$	V_{F5a}	1480	-	mV_{DC}	
	$T_A = 25^\circ\text{C}$	V_{F5b}	1400	-		
	$T_A = 100^\circ\text{C}$	V_{F5c}	1240	-		
	$T_A = 125^\circ\text{C}$	V_{F5d}	1190	-		
	$T_A = 150^\circ\text{C}$	V_{F5e}	1150	-		
Reverse Leakage Current (Rated V_R , 300 μsec pulse minimum)	$T_A = 25^\circ\text{C}$	I_{R1}	0.1	10	μA	
	$T_A = 100^\circ\text{C}$	I_{R2}	6	-		
	$T_A = 125^\circ\text{C}$	I_{R3}	25	500		
	$T_A = 150^\circ\text{C}$	I_{R4}	80	-		
Junction Capacitance ($V_R = 5 \text{ V}_{\text{DC}}$, $T_A = 25^\circ\text{C}$, $f = 1 \text{ MHz}$)	$V_R = 5 \text{ V}$	C_J	190	-	pF	
	$V_R = 10 \text{ V}$		140	250		
Reverse Recovery $I_F = 0.5 \text{ A}$, $I_R = 1 \text{ A}$, $I_{rr} = 0.25 \text{ A}$ $I_F = 1 \text{ A}$, $I_R = 1 \text{ A}$, $I_{rr} = 0.1 \text{ A}$ $I_F = 10 \text{ A}$, $di_F/dt = 45 \text{ A/us}$, $T_a = 25^\circ\text{C}$ $I_F = 10 \text{ A}$, $di_F/dt = 45 \text{ A/us}$, $T_a = 25^\circ\text{C}$ $I_F = 10 \text{ A}$, $di_F/dt = 45 \text{ A/us}$, $T_a = 100^\circ\text{C}$ $I_F = 10 \text{ A}$, $di_F/dt = 45 \text{ A/us}$, $T_a = 100^\circ\text{C}$ $I_F = 10 \text{ A}$, $di_F/dt = 100 \text{ A/us}$, $T_a = 25^\circ\text{C}$ $I_F = 10 \text{ A}$, $di_F/dt = 100 \text{ A/us}$, $T_a = 25^\circ\text{C}$		t_{rr1}	32	35	ns	
		t_{rr2}	75	-	ns	
		t_{rr3}	46	-	ns	
		I_{RM3}	1.8	-	A	
		t_{rr4}	115	-	ns	
		I_{RM4}	3.8	-	A	
		t_{rr5}	45	-	ns	
		I_{RM5}	3.7	-	A	
	Forward Recovery	$I_F = 1 \text{ A}$	t_{fr}	60	-	ns
			V_{fr}	880	-	mV

NOTES:

- 1/ For Ordering Information, Price, Operating Curves, and Availability – Contact Factory.
- 2/ Screening Based on MIL-PRF-19500.

NOTE: All specifications are subject to change without notification. SCD's for these devices should be reviewed by SSDI prior to release.

DATA SHEET #: RC0128B

DOC