

RoHS Compliant Product

Description

The SJ117A is a low dropout at positive adjustable or fixed-mode regulator with min. of 1A output current capability. The product is specifically designed to provide well-regulated supply for low voltage IC applications such as high-speed bus termination and low current 3.3V logic supply. SJ117A is also well suited for other applications such as VGA cards. SJ117A is guaranteed to have lower than 1.4V dropout at full load current making it ideal to provide well regulated outputs of 1.25 to 5 with 6.4V to 12V input supply.

Features

- * 1.4V Max. Dropout Full Load Current
- * 3-Terminal Adjustable or Fixed 1.5V, 1.8V, 2.5V, 3.3V, 5.0V
- * Output Current Limiting
- * Good Noise Rejection
- * Fast Transient Response
- * Built-in Thermal Shutdown

Applications

- * Communication
- * PC Peripheral

TO-252

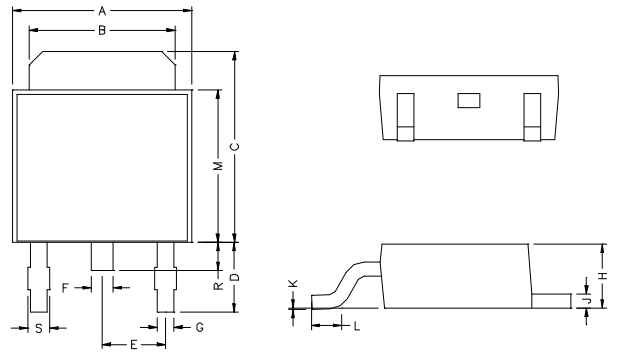

REF.	Millimeter		REF.	Millimeter	
	Min.	Max.		Min.	Max.
A	6.40	6.80	G	0.50	0.70
B	5.20	5.50	H	2.20	2.40
C	6.80	7.20	J	0.45	0.55
D	2.20	2.80	K	0	0.15
E	2.30 REF.		L	0.90	1.50
F	0.70	0.90	M	5.40	5.80
S	0.60	0.90	R	0.80	1.20

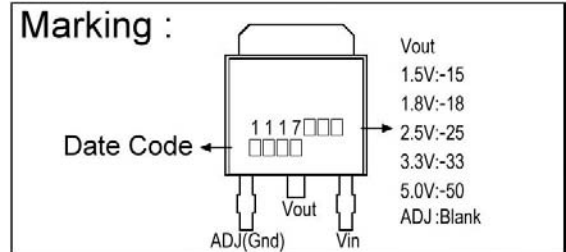

Typical Circuit

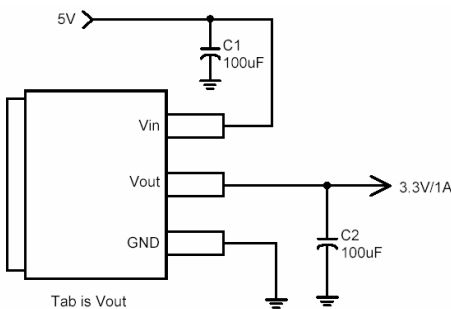

(5V/3.3V fixed output)

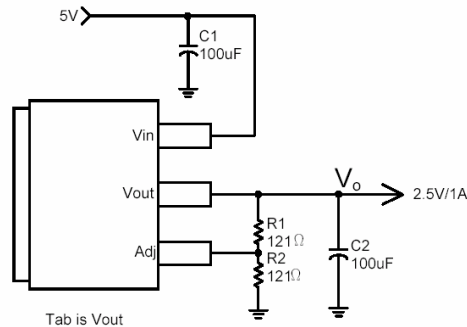

(5V/2.5V ADJ output)

$$\text{Note: } V_o = V_{\text{REF}} * \left(1 + \frac{R_2}{R_1}\right)$$

Block Diagram

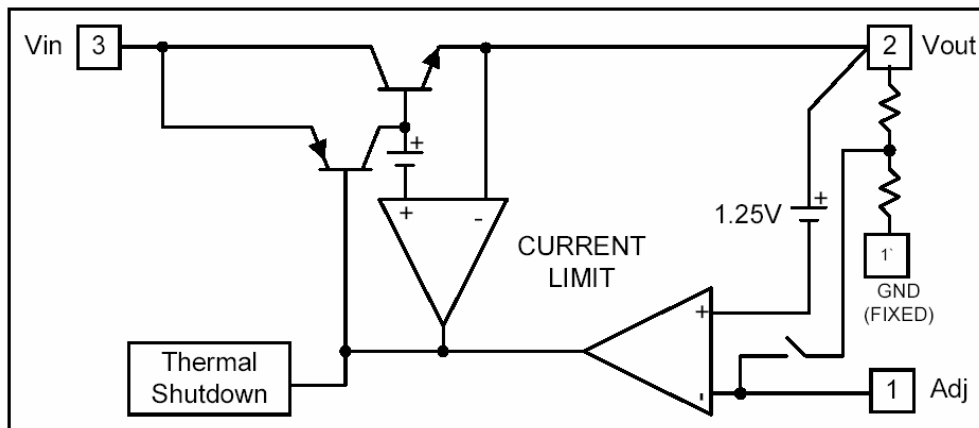

Pin Descriptions

Name	I/O	Pin#	Function
Adj (GND)	I	1	A resistor divider from this pin to the Vout pin and ground sets the output voltage (Ground only for fixed mode)
Vout	O	2	The output of the regulator. A minimum of 10uF capacitor must be connected from this pin to ground to insure stability.
Vin	I	3	The input pin of regulator. Typically a large storage capacitor is connected from this pin to ground to insure that the input voltage does not sag below the minimum dropout voltage during the load transient response. This pin must always be 1.3V higher than Vout in order for the device to regulate properly.

Absolute Maximum Ratings

Parameter	Symbol	Ratings	Unit
DC Supply Voltage	V_{IN}	-0.3 to 12	V
Power Dissipation	P_D	Internally Limited	
Storage Temperature Range	T_{ST}	-65~+150	°C
Operating Junction Temperature Range	T_{OP}	0~+150	°C

Electrical Characteristics

PARAMETER	CONDITIONS		MIN	TYP	MAX	UNIT
Reference Voltage	SJ1117AADJ	$I_o=10\text{mA}, T_j=25^\circ\text{C}, (V_{in}-V_{out})=1.5\text{V}$	1.225	1.250	1.275	V
Output Voltage	SJ1117A-1.5	$I_o=10\text{mA}, T_j=25^\circ\text{C}, 3\text{V} \leq V_{in} \leq 12\text{V}$	1.470	1.500	1.530	V
	SJ1117A-1.8	$I_o=10\text{mA}, T_j=25^\circ\text{C}, 3.3\text{V} \leq V_{in} \leq 12\text{V}$	1.764	1.800	1.836	V
	SJ1117A-2.5	$I_o=10\text{mA}, T_j=25^\circ\text{C}, 4\text{V} \leq V_{in} \leq 12\text{V}$	2.450	2.500	2.550	V
	SJ1117A-3.3	$I_o=10\text{mA}, T_j=25^\circ\text{C}, 4.8\text{V} \leq V_{in} \leq 12\text{V}$	3.235	3.300	3.365	V
	SJ1117A-5.0	$I_o=10\text{mA}, T_j=25^\circ\text{C}, 6.5\text{V} \leq V_{in} \leq 12\text{V}$	4.900	5.000	5.100	V
Line Regulation	SJ1117A-XXX	$I_o=10\text{mA}, V_{out}+1.5\text{V} < V_{in} < 12\text{V}, T_j=25^\circ\text{C}$	-	-	0.2	%
Load Regulation	SJ1117AADJ	$V_{in}=3.3\text{V}, V_{adj}=0, 0\text{mA} < I_o < 1\text{A}, T_j=25^\circ\text{C}$ (Note 1,2)	-	-	1	%
	SJ1117A-1.5	$V_{in}=3\text{V}, 0\text{mA} < I_o < 1\text{A}, T_j=25^\circ\text{C}$ (Note 1,2)	-	12	15	mV
	SJ1117A-1.8	$V_{in}=3.3\text{V}, 0\text{mA} < I_o < 1\text{A}, T_j=25^\circ\text{C}$ (Note 1,2)	-	15	18	mV
	SJ1117A-2.5	$V_{in}=4\text{V}, 0\text{mA} < I_o < 1\text{A}, T_j=25^\circ\text{C}$ (Note 1,2)	-	20	25	mV
	SJ1117A-3.3	$V_{in}=5\text{V}, 0\text{mA} < I_o < 1\text{A}, T_j=25^\circ\text{C}$ (Note 1,2)	-	26	33	mV
	SJ1117A-5.0	$V_{in}=8\text{V}, 0\text{mA} < I_o < 1\text{A}, T_j=25^\circ\text{C}$ (Note 1,2)	-	40	50	mV
Dropout Voltage ($V_{in}-V_{out}$)	SJ1117AADJ/1.5 /1.8/2.5/3.3/5.0	$I_o=1\text{A}, (\Delta V_{out}=0.1\% V_{out})$	-	1.3	1.4	V
Current Limit	SJ1117AADJ/1.5 /1.8/2.5/3.3/5.0	$V_{in}-V_{out}=5\text{V}$	1.1	-	-	A
Minimum Load Current	SJ1117A-XXX	$0^\circ\text{C} \leq T_j \leq 125^\circ\text{C}$	-	5	10	mA
Thermal Regulation	$T_A=25^\circ\text{C}, 30\text{ms pulse}$		-	0.008	0.04	%/W
Ripple Rejection	$F=120\text{Hz}, C_{out}=25\mu\text{F Tantalum}, I_{out}=1\text{A}$					
	SJ1117A-XXX	$V_{in}=V_{out}+3\text{V}$	-	60	70	dB
Temperature Stability	$I_o=10\text{mA}$		-	0.5	-	%
θ_{JA} Thermal Resistance Junction-to-Ambient(No heat sink ;No air flow)			-	92	-	$^\circ\text{C}/\text{W}$
θ_{JC} Thermal Resistance Junction-to-Case	Control Circuitry/Power Transistor		-	10	-	$^\circ\text{C}/\text{W}$

Note 1: See thermal regulation specifications for changes in output voltage due to heating effects. Line and load regulation are measured at a constant junction Temperature by low duty cycle pulse testing. Load regulation is measured at the output lead =1/18" from the package.

Note 2: Line and load regulation are guaranteed up to the maximum power dissipation of 15W. Power dissipation is determined by the difference between input and output and the output current. Guaranteed maximum power dissipation will not be available over the full input/output range.

Note 3: Quiescent current is defined as the minimum output current required in maintaining regulation. At 12V input/output differential the device is guaranteed to regulate if the output current is greater than 10mA.

Characteristics Curve

