

Version :1.0

<p style="text-align: center;">TECHNICAL SPECIFICATION</p> <p style="text-align: center;">MODEL NO. : PD121XL4</p>
--

The content of this information is subject to be changed without notice.
Please contact PVI or its agent for further information.

Customer's Confirmation



Customer _____

Date _____

By _____

PVI's Confirmation

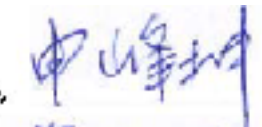
FOR MORE INFORMATION:
AZ DISPLAYS, INC.
75 COLUMBIA, ALISO VIEJO, CA 92656
[Http://www.AZDISPLAYS.com](http://www.AZDISPLAYS.com)

Confirmed By 
Prepared By 

Revision History

Rev.	Eng.	Issued Date	Revised Contents
0.1	Sarah Huang	July 18,2008	Preliminary
0.2	Sarah Huang	Sep 02,2008	Modify Page 5 4. Mechanical Drawing of TFT-LCD Module Modify Page 16 13. Optical Characteristics Horizontal View angle from 70 to 75 Vertical View angle from 50/40 to 75/45 Contrast Ratio from 400 to 600 nit
0.3	Sarah Huang	Nov 18,2008	Modify Page 5 4. Mechanical Drawing of TFT-LCD Module
0.4	Sarah Huang	Feb 5, 2009	Modify Page 5,6 4. Mechanical Drawing of TFT-LCD Module
1.0	Sarah Huang	Jan 07, 2010	Modify Page 7 5. Input / Output Terminals Modify Page 16 13. Optical Characteristics Vertical View angle from 75/45 to 65/55 Uniformity from 75% to 70% Add Page 21 16. Packing Diagram

TECHNICAL SPECIFICATION**CONTENTS**

NO.	ITEM	PAGE
-	Cover	1
-	Revision History	2
-	Contents	3
1	Application	4
2	Features	4
3	Mechanical Specifications	4
4	Mechanical Drawing of TFT-LCD Module	5
5	Input / Output Terminals	7
6	Absolute Maximum Ratings	8
7	Electrical Characteristics	9
8	Pixel Arrangement	10
9	Display Color and Gray Scale Reference	11
10	Block Diagram	12
11	Interface Timing	13
12	Power On Sequence	15
13	Optical Characteristics	16
14	Handling Cautions	19
15	Reliability Test	20
16	Packing Diagram	21

1. Application

The PD121XL4 is a 12.1" TFT-LCD module with LED B/L and a 20-pin LVDS interface. This module supports 1024 x768 XGA mode and displays 262,144 colors. This module can apply TFT-LCD monitor, TV, Factory application, Amusement Vehicle, and so on.

2. Features

- Wide viewing angle
- Fast response time
- High color saturation
- XGA (1024 x768 pixels) resolution
- Wide operating temperature
- DE (Data Enable) mode
- LVDS (Low Voltage Differential Signaling) interface
- RoHS Compliance

3. Mechanical Specifications

Parameter	Specifications	Unit
Screen Size	12.1 (diagonal)	inch
Display Format	1024×(R, G, B)×768	dot
Display Colors	262,144	
Active Area	245.76(H)×184.32(V)	mm
Pixel Pitch	0.240(H)×0.240(V)	mm
Pixel Configuration	RGB Vertical Stripe	
Outline Dimension	260.5(W)× 204(H)× 7.5(typ.) (D)	mm
Weight	473±20	g
Back-light	54-LED	
Surface treatment	Anti-glare	
Display mode	Normally White	
Gray scale inversion direction	12 O'clock	Note 13-2

4. Mechanical Drawing of TFT-LCD Module

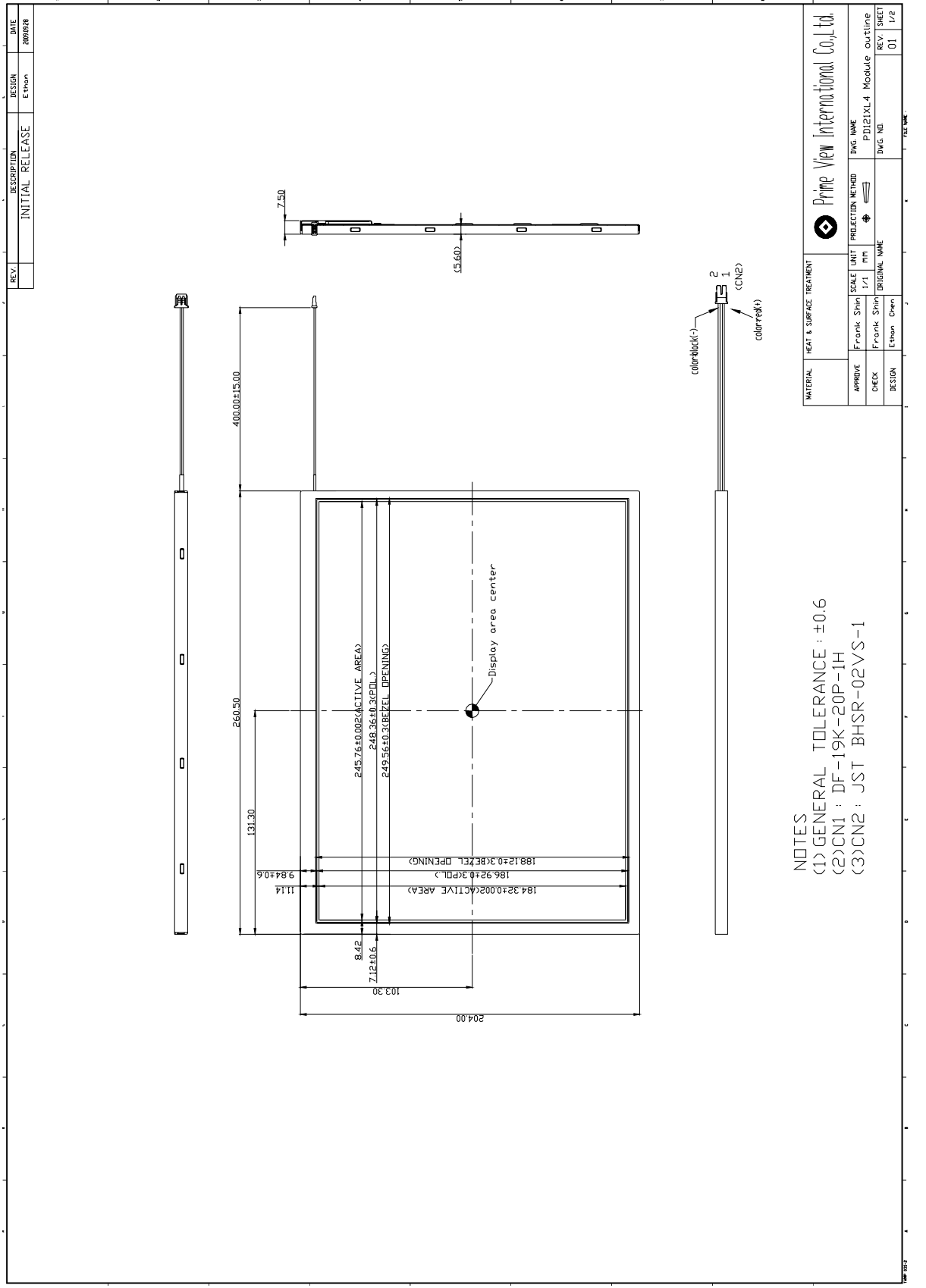

NOTES
 (1) GENERAL TOLERANCE : ±0.6
 (2) CN1 : DF-19K-20P-1H
 (3) CN2 : JST BHSR-02VS-1

REV.	DESCRIPTION	DESIGN	DATE
	INITIAL RELEASE	Ethan	2009/08

MATERIAL	HEAT & SURFACE TREATMENT	Prime View International Co., Ltd.	
APPROVE	SCALE	DWG. NAME	DWG. UNIT
Frank Shin	1/1 mm	PD121XL4 Module	outline
CHECK	PROJECTION METHOD	DWG. NO.	REV. SHEET
Frank Shin	☺		01
DESIGN	ORIGINAL NAME		1/2
Ethan Chen			

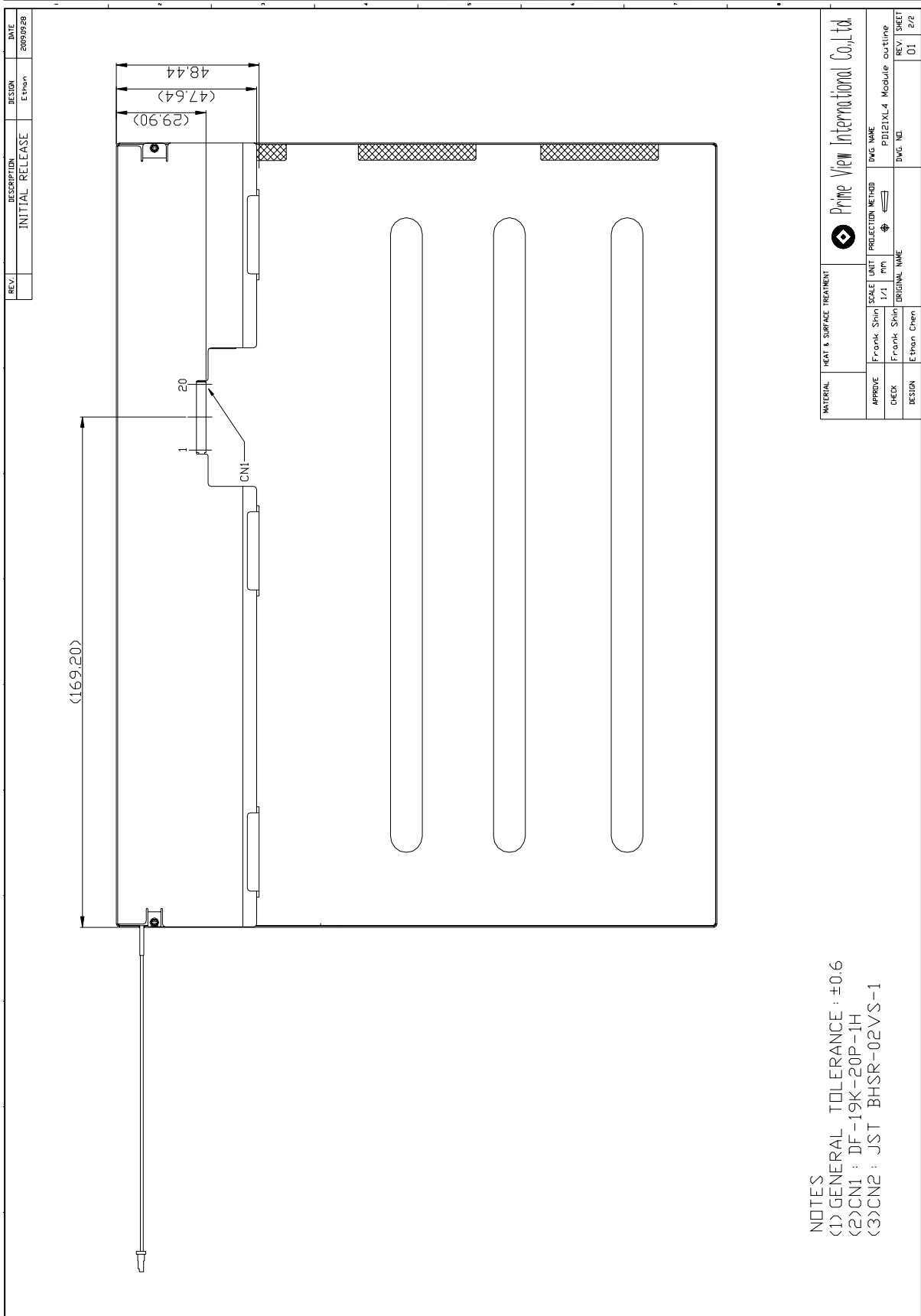

NOTES
 (1) GENERAL TOLERANCE : ±0.6
 (2)CNI : DF-19K-20P-1H
 (3)CNI : JST BHSR-02VS-1

MATERIAL	HEAT & SURFACE TREATMENT	PRIME VIEW INTERNATIONAL CO., LTD.	
APPROVE	FRANK SHIN	SCALE	UNIT
CHECK	FRANK SHIN	1/1	MM
DESIGN	ETYAN CHEN	PROJECTION METHOD	ORIGINAL NAME
		First Angle	
		DWG. NAME	REV. SHEET
		PD121XL4 Module outline	01 2/2

5. Input / Output Terminals

5-1) TFT-LCD Panel Driving

Connector type: DF19K-20P-1H

CN1	Interface connector	Hirose/DF19L-20P-1H or equivalent
	User side connector	Hirose/DF19G-20S-1C or equivalent

Pin No.	Symbol	Function	Remark
1	VSS	Ground	
2	VDD1	Power Supply: +3.3V	
3	VDD2	Power Supply: +3.3V	
4	NC	NC	
5	NC	NC	
6	NC	NC	
7	NC	NC	
8	RIN0-	LVDS Negative data signal (-)	Tx pin #48
9	RIN0+	LVDS Positive data signal (+)	Tx pin #47
10	VSS	Ground	
11	RIN1-	LVDS Negative data signal (-)	Tx pin #46
12	RIN1+	LVDS Positive data signal (+)	Tx pin #45
13	VSS	Ground	
14	RIN2-	LVDS Negative data signal (-)	Tx pin #42
15	RIN2+	LVDS Positive data signal (+)	Tx pin #41
16	VSS	Ground	
17	RCLKIN-	LVDS Negative clock signal (-)	Tx pin #40
18	RCLKIN+	LVDS Positive clock signal (+)	Tx pin #39
19	VSS	Ground	
20	VSS	Ground	

5-2) Backlight driving

Connector type: JST BHSR-02VS-1, PIN No 2 pin

Pin No	Symbol	Description	Remark
1	+	Input terminal (Anode)	Wire color: Red
2	-	Input terminal (Cathode)	Wire Color: Black

5-3) LVDS Interface

LVDS Transmitter: THC63LVDM83A or equivalent

Input signal	Transmitter		Interface	
	Pin No	Pin No	System (Tx)	TFT-LCD (Rx)
R0	51	48 47	OUT0- OUT0+	IN0- IN0+
R1	52			
R2	54			
R3	55			
R4	56			
R5	3			
G0	4	46 45	OUT1- OUT1+	IN1- IN1+
G1	6			
G2	7			
G3	11			
G4	12			
G5	14			
B0	15	42 41	OUT2- OUT2+	IN2- IN2+
B1	19			
B2	20			
B3	22			
B4	23			
B5	24			
HSYNC	27	40	CLKOUT-	CLKIN-
VSYNC	28			
DE	30			
MCLK	31	39	CLKOUT+	CLKIN+

6. Absolute Maximum Ratings:

The followings are maximum values, which if exceeded, may cause faulty operation or damage to the unit.

GND=0V, Ta=25°C

Parameters	Symbol	MIN.	MAX.	Unit	Remark
Logic Power Supply	V _{DD}	VSS-0.3	+4.0	V	
Logic Input Voltage	V _{IN}	VSS-0.3	V _{DD} +0.3	V	Note 6-1

Note 6-1: Permanent damage to the device may occur if maximum values are exceeded. Function operation should be restricted to the conditions described under Normal Operating Conditions.

7. Electrical Characteristics

7-1) Recommended Operating Conditions:

Ta=25 ± 2°C

Parameter	Symbol	Value			Unit	Note
		Min.	Typ.	Max.		
Power Supply Voltage	V _{DD}	3.0	3.3	3.6	V	Note 7-1
Power Supply Current	I _{DD}	-	280	485	mA	
Power Consumption	P _{DD}	-	0.9	1.6	W	Note 7-2
LVDS differential voltage	V _{ID}	-100	-	+100	mV	
LVDS common input voltage	V _{ic}	-	1.2	-	V	

Note7-1: The module is recommended to operate within specification ranges listed above for normal function.

Note 7-2: P_{DD}=V_{DD} × I_{DD}

7-2) Recommended driving condition for LED backlight:

Ta = 25°C

Parameter	Symbol	Min	TYP	MAX	Unit	Remark
Supply voltage of LED backlight	V _{LED1}	-	9.9	(10.8)	V	Note 7-3
Supply current of LED backlight	I _{LED1}	-	20	-	mA	Note 7-4
Backlight Power Consumption	P _{LED}	-	3.56	(3.89)	W	Note 7-3/7-5

Note 7-3: I_{LED} = 20mA, Constant Current.

Note 7-4: The LED driving condition is defined for each LED module. (3 LED Serial)
Input current = 360mA

Note 7-5: P_{LED} = V_{LED1} * I_{LED1} +V_{LED2} * I_{LED2} +.....+V_{LED17} * I_{LED17} +V_{LED18} * I_{LED18}

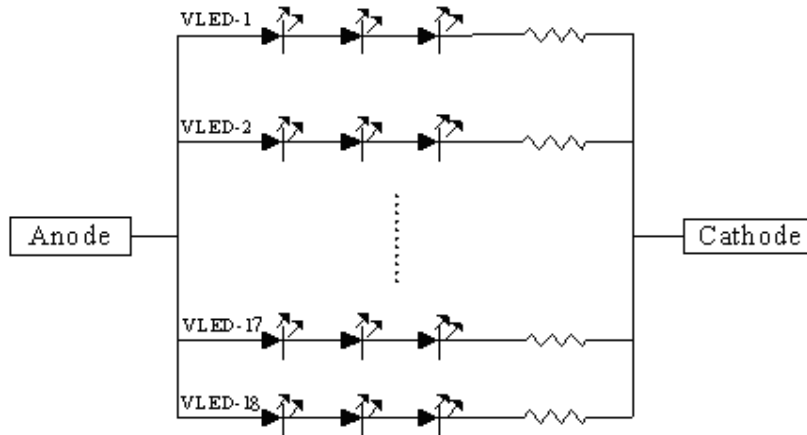

8. Pixel Arrangement

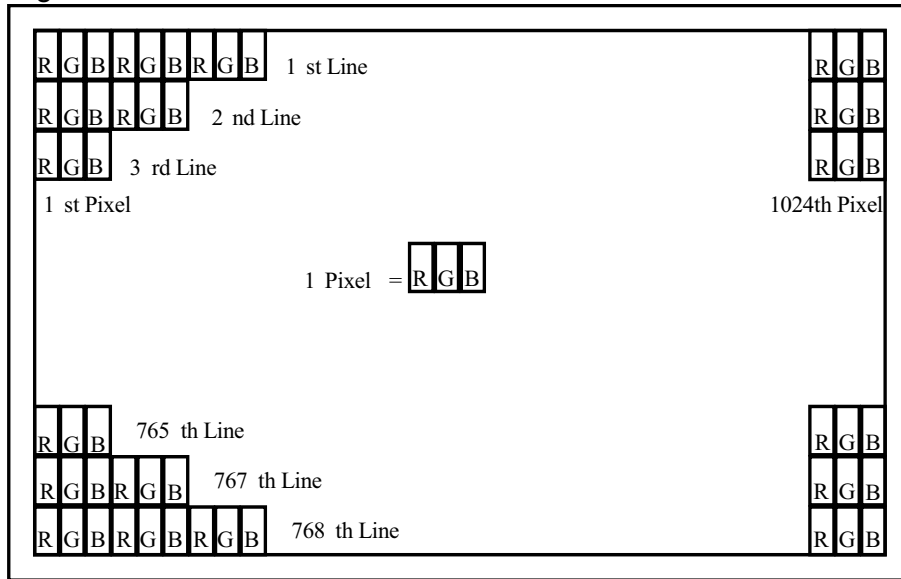

9. Display Color and Gray Scale Reference

Color		Data Signal																	
		Red						Green						Blue					
		R5	R4	R3	R2	R1	R0	G5	G4	G3	G2	G1	G0	B5	B4	B3	B2	B1	B0
Basic Colors	Black	0	0	0	0	0	0	0	0	0	0	0	0	0	0	0	0	0	0
	Red	1	1	1	1	1	1	0	0	0	0	0	0	0	0	0	0	0	0
	Green	0	0	0	0	0	0	1	1	1	1	1	1	0	0	0	0	0	0
	Blue	0	0	0	0	0	0	0	0	0	0	0	0	1	1	1	1	1	1
	Cyan	0	0	0	0	0	0	1	1	1	1	1	1	1	1	1	1	1	1
	Magenta	1	1	1	1	1	1	0	0	0	0	0	0	1	1	1	1	1	1
	Yellow	1	1	1	1	1	1	1	1	1	1	1	1	0	0	0	0	0	0
	White	1	1	1	1	1	1	1	1	1	1	1	1	1	1	1	1	1	1
Gray Scale Of Red	Red(0)/Dark	0	0	0	0	0	0	0	0	0	0	0	0	0	0	0	0	0	0
	Red(1)	0	0	0	0	0	1	0	0	0	0	0	0	0	0	0	0	0	0
	Red(2)	0	0	0	0	1	0	0	0	0	0	0	0	0	0	0	0	0	0
	:	:	:	:	:	:	:	:	:	:	:	:	:	:	:	:	:	:	:
	:	:	:	:	:	:	:	:	:	:	:	:	:	:	:	:	:	:	:
	:	:	:	:	:	:	:	:	:	:	:	:	:	:	:	:	:	:	:
	Red(61)	1	1	1	1	0	1	0	0	0	0	0	0	0	0	0	0	0	0
	Red(62)	1	1	1	1	1	0	0	0	0	0	0	0	0	0	0	0	0	0
Red(63)	1	1	1	1	1	1	0	0	0	0	0	0	0	0	0	0	0	0	
Gray Scale Of Green	Green(0)/Dark	0	0	0	0	0	0	0	0	0	0	0	0	0	0	0	0	0	0
	Green(1)	0	0	0	0	0	0	0	0	0	0	1	0	0	0	0	0	0	0
	Green(2)	0	0	0	0	0	0	0	0	0	1	0	0	0	0	0	0	0	0
	:	:	:	:	:	:	:	:	:	:	:	:	:	:	:	:	:	:	:
	:	:	:	:	:	:	:	:	:	:	:	:	:	:	:	:	:	:	:
	:	:	:	:	:	:	:	:	:	:	:	:	:	:	:	:	:	:	:
	Green(61)	0	0	0	0	0	0	1	1	1	1	0	1	0	0	0	0	0	0
	Green(62)	0	0	0	0	0	0	1	1	1	1	1	0	0	0	0	0	0	0
Green(63)	0	0	0	0	0	0	1	1	1	1	1	1	0	0	0	0	0	0	
Gray Scale Of Blue	Blue(0)/Dark	0	0	0	0	0	0	0	0	0	0	0	0	0	0	0	0	0	0
	Blue(1)	0	0	0	0	0	0	0	0	0	0	0	0	0	0	0	0	0	1
	Blue(2)	0	0	0	0	0	0	0	0	0	0	0	0	0	0	0	0	1	0
	:	:	:	:	:	:	:	:	:	:	:	:	:	:	:	:	:	:	:
	:	:	:	:	:	:	:	:	:	:	:	:	:	:	:	:	:	:	:
	:	:	:	:	:	:	:	:	:	:	:	:	:	:	:	:	:	:	:
	Blue(61)	0	0	0	0	0	0	0	0	0	0	0	0	1	1	1	1	0	1
	Blue(62)	0	0	0	0	0	0	0	0	0	0	0	0	1	1	1	1	1	0
Blue(63)	0	0	0	0	0	0	0	0	0	0	0	0	1	1	1	1	1	1	
Gray Scale Of Black	Black(0)/Dark	0	0	0	0	0	0	0	0	0	0	0	0	0	0	0	0	0	0
	Gray (1)	0	0	0	0	0	1	0	0	0	0	1	0	0	0	0	0	0	1
	Gray (2)	0	0	0	0	1	0	0	0	0	1	0	0	0	0	0	0	1	0
	:	:	:	:	:	:	:	:	:	:	:	:	:	:	:	:	:	:	:
	:	:	:	:	:	:	:	:	:	:	:	:	:	:	:	:	:	:	:
	:	:	:	:	:	:	:	:	:	:	:	:	:	:	:	:	:	:	:
	Gray (61)	1	1	1	1	0	1	1	1	1	0	1	1	1	1	1	0	1	1
	Gray (62)	1	1	1	1	1	0	1	1	1	1	0	1	1	1	1	1	1	0
White(63)	1	1	1	1	1	1	1	1	1	1	1	1	1	1	1	1	1	1	

Note 9-1: 0: Low Level Voltage, 1: High Level Voltage

10. Block Diagram

10-1) TFT-module Block Diagram

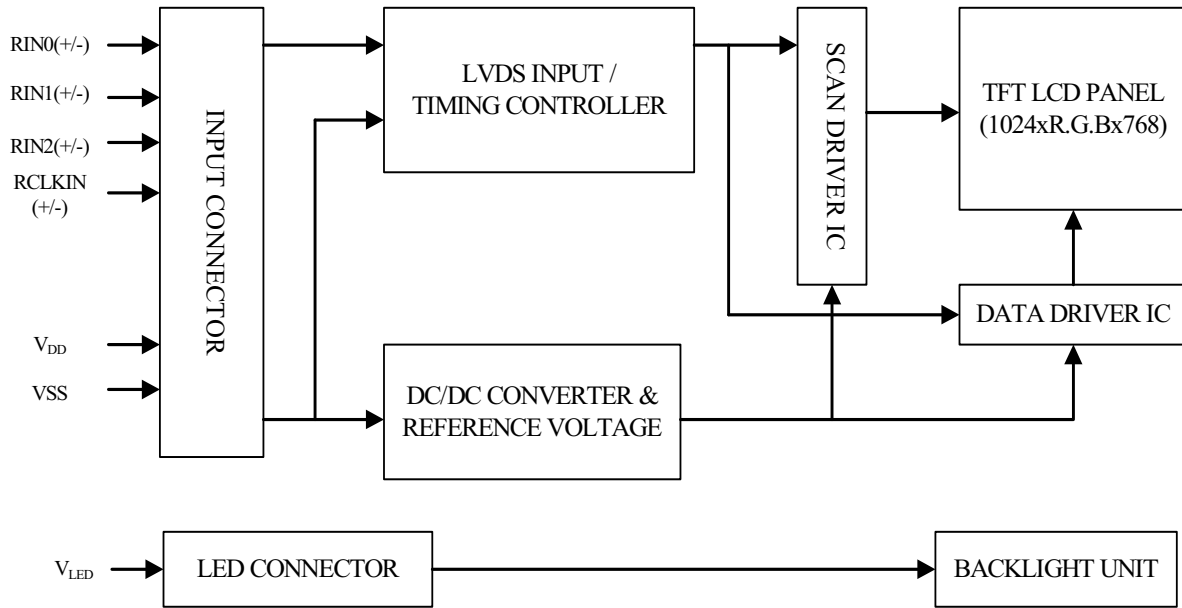

11. Interface Timing

11-1) The 12.1" XGA LCM is operated by the only DE mode (LVDS Transmitter Input)

Item	Symbols	Min	Typ	Max	Unit	
Clock	Frequency	1/Tc	-	65	80	MHz
	High Time	Tch	4.5	-	-	ns
	Low Time	Tcl	4.5	-	-	ns
Data	Setup Time	Tds	2.7	-	-	ns
	Hold Time	Tdh	0	-	-	ns
Data Enable Setup Time	Tes	2.7	-	-	ns	
Frame Period	Tv	772	806	1022	lines	
Vertical Display Period	Tvd	768	768	768	lines	
One Line Scanning Period	Th	1100	1344	2046	clocks	
Horizontal Display Period	Thd	1024	1024	1024	clocks	

11-2) LVDS Rx interface timing parameter

The specification of the LVDS Rx interface timing parameter

Item	Symbol	Min	Typ	Max	Unit	Remark
CLKIN Period	tRCIP	12.5	15.38		nsec	
Input Data 0	tRIP0	-0.4	0.0	+0.4	nsec	
Input Data 1	tRIP1	tRCIP/7-0.4	tRCIP/7	tRCIP/7+0.4	nsec	
Input Data 2	tRIP2	2 × tRCIP/7-0.4	2 × tRCIP/7	2 × tRCIP/7+0.4	nsec	
Input Data 3	tRIP3	3 × tRCIP/7-0.4	3 × tRCIP/7	3 × tRCIP/7+0.4	nsec	
Input Data 4	tRIP4	4 × tRCIP/7-0.4	4 × tRCIP/7	4 × tRCIP/7+0.4	nsec	
Input Data 5	tRIP5	5 × tRCIP/7-0.4	5 × tRCIP/7	5 × tRCIP/7+0.4	nsec	
Input Data 6	tRIP6	6 × tRCIP/7-0.4	6 × tRCIP/7	6 × tRCIP/7+0.4	nsec	

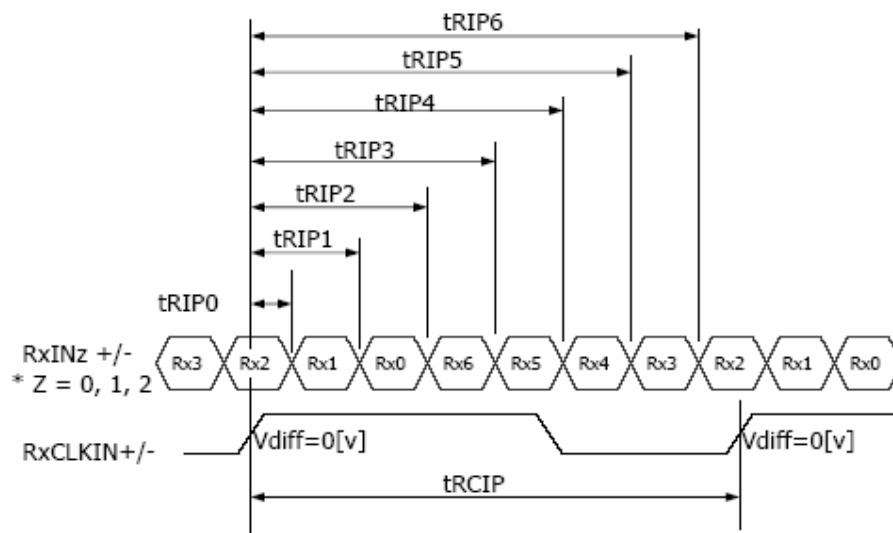

$$* V_{diff} = (RINz+) - (RINz-), (RCLKIN+) - (RCLKIN-)$$

11-3) Signal Timing Waveforms of Interface Signal (DE Mode)

A) Vertical Timing Waveforms

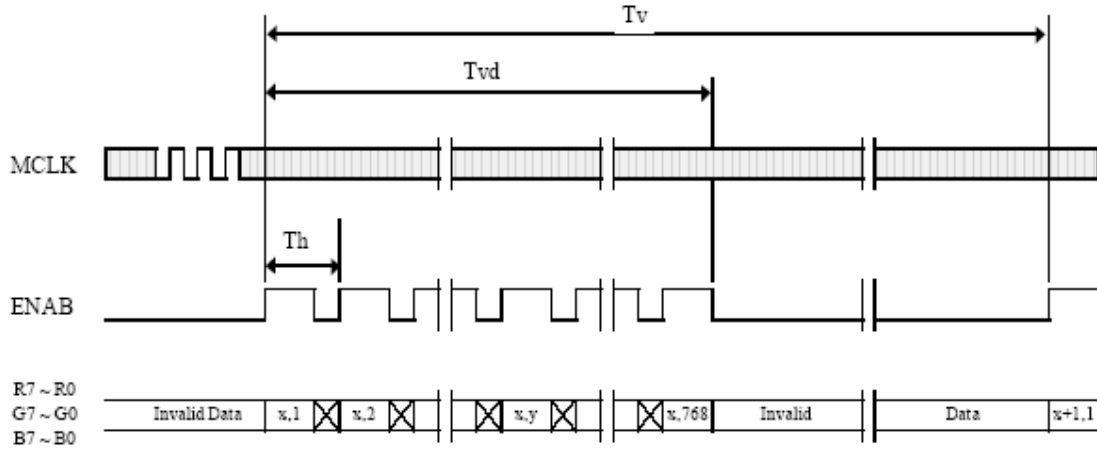

B) Horizontal Timing Waveforms

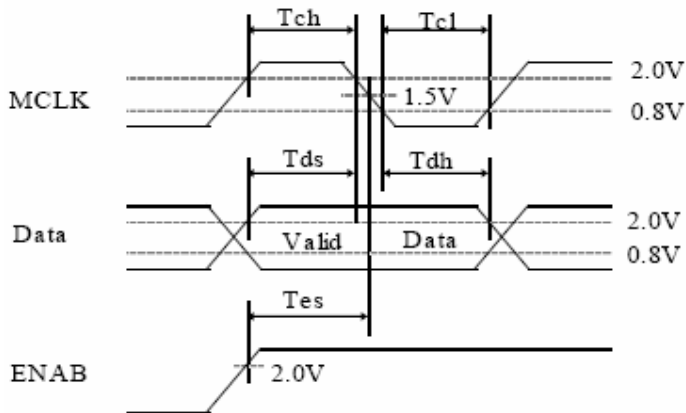
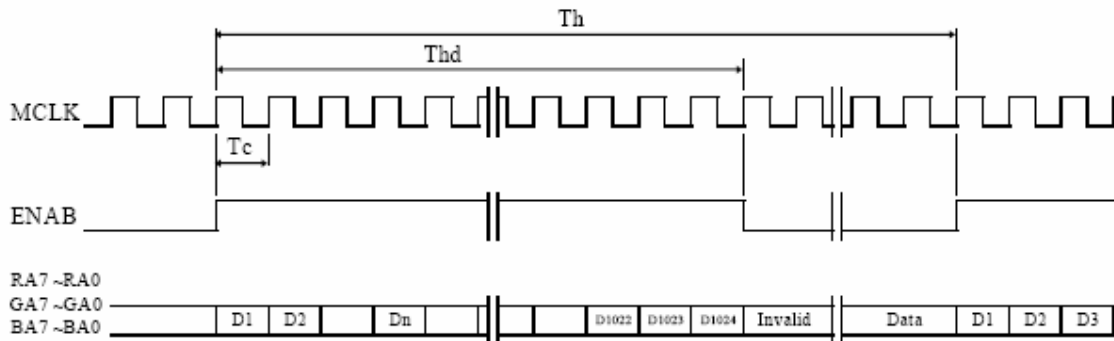

12. Power On Sequence

To prevent a latch-up or DC operation of the LCD module, the power on/off sequence shall be as shown in below

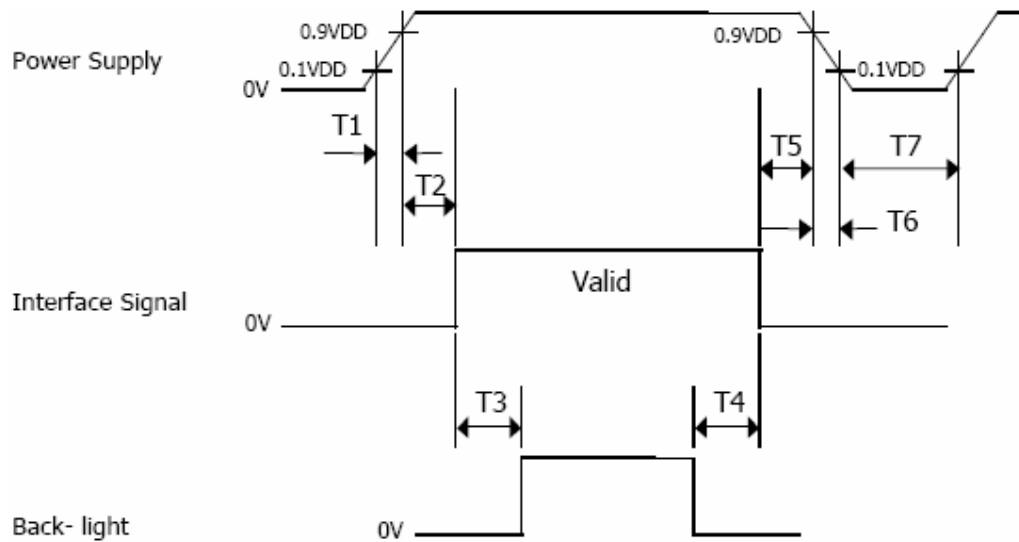

- $0 < T1 \leq 10 \text{ ms}$
- $0 < T2 \leq 50 \text{ ms}$
- $200 \text{ ms} \leq T3$
- $0 \text{ ms} \leq T4, 0 \text{ ms} \leq T5$
- $0 \leq T6 \leq 10 \text{ ms}$
- $150 \text{ ms} \leq T7$

Note 12-1: When the power supply VDD is 0V, keep the level of input signals on the low or keep high impedance.

Note 12-2: Do not keep the interface signal high impedance when power is on.

Note 12-3: Back Light must be turn on after power for logic and interface signal are valid.

13. Optical Characteristics

13.1) Specification:

Ta=25°C

Parameter	Symbol	Condition	MIN.	TYP.	MAX.	Unit	Remarks
Viewing Angle	Horizontal	θ	70	75	-	deg	Note 13-2
	Vertical	θ (to 12 o'clock)	60	65	-	deg	
		θ (to 6 o'clock)	50	55	-	deg	
Contrast Ratio	CR	$\theta = 0^\circ$	500	600	-	-	Note 13-3
Response time	Rise	Tr	-	10	20	ms	Note 13-5
	Fall	Tf	-	20	40	ms	
Brightness	L	$\theta = 0^\circ / \varphi = 0$	400	550	-	cd/m ²	Note 13-1
LED Life Time	-	-	20000	30000	-	hrs	Note 13-4
White Chromaticity	x	$\theta = 0^\circ / \varphi = 0$	0.26	0.31	0.36	-	Note 13-1
	y	$\theta = 0^\circ / \varphi = 0$	0.29	0.34	0.39	-	
Uniformity	U	-	65	70	-	%	Note 13-6
Cross Talk Ratio	CTK	-	-	-	3.5	%	Note 13-7

Note 13-1: Topcon BM-5A or BM-7 fast luminance meter 1° field of view is used in the testing.

Note 13-2: The definitions of viewing angles are as follow

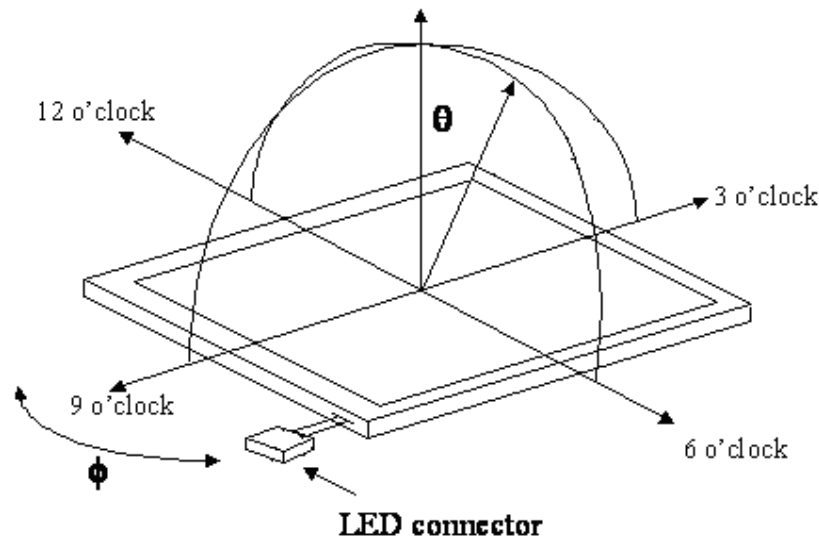

Note 13-3: The definition of contrast ratio $CR = \frac{\text{Luminance when Testing point is White}}{\text{Luminance when Testing point is Black}}$

Note 13-4: The "LED Life time " is defined as the module brightness decrease to 50% original Brightness that the ambient temperature is 25°C and $I_{LED} = 360\text{mA}$.

Note 13-5: Definition of Response Time T_r and T_f

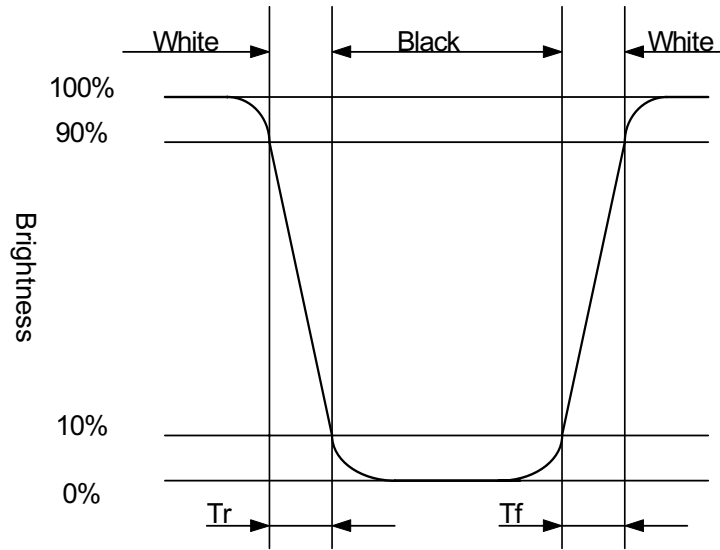

Note 13-6: The uniformity of LCD is defined as

$$U = \frac{\text{The Minimum Brightness of the 9 testing Points}}{\text{The Maximum Brightness of the 9 testing Points}}$$

Luminance meter: BM-5A or BM-7 fast (TOPCON)

Measurement distance: 500 mm +/- 50 mm

Ambient illumination: < 1 Lux

Measuring direction: Perpendicular to the surface of module

The test pattern is white (Gray Level 63).

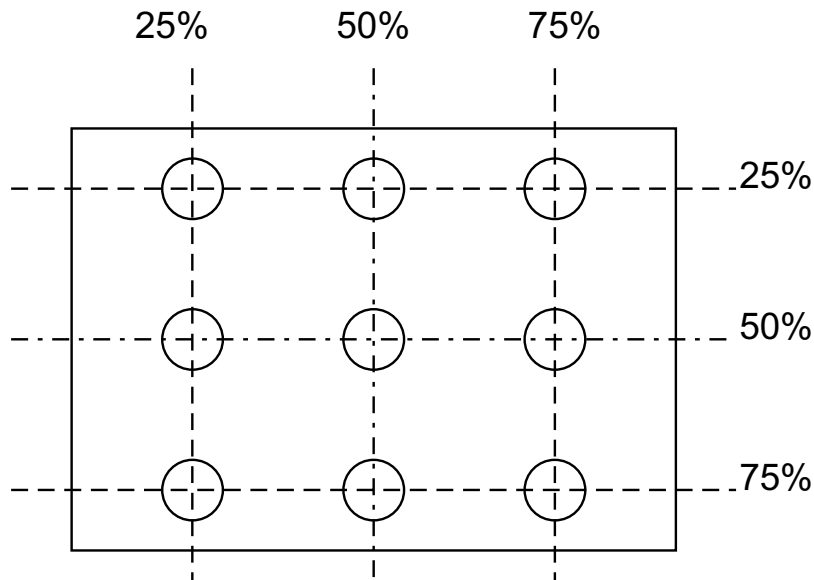

Note 13-7: Cross Talk (CTK) = $\frac{|YA-YB|}{YA} \times 100\%$

YA: Brightness of Pattern A
 YB: Brightness of Pattern B
 Luminance meter: BM 5A (TOPCON)
 Measurement distance: 500 mm +/- 50 mm
 Ambient illumination: < 1 Lux
 Measuring direction: Perpendicular to the surface of module

Pattern A
 (Gray Level 31)

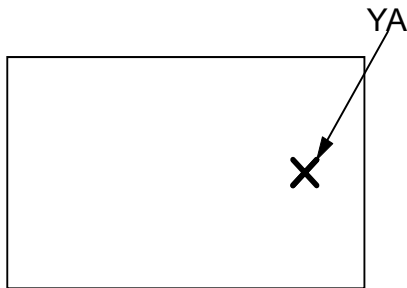

Pattern B
 (Gray Level 31, central
 black box exclusive)

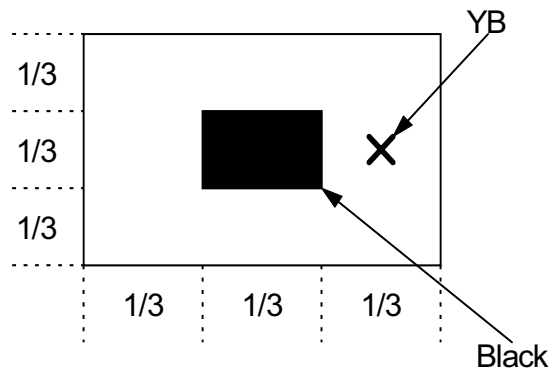

X: Measuring Point (A and B are at the same point.)

(Gray Level 0)

14. Handling Cautions

14-1) Mounting of module

- a) Please power off the module when you connect the input/output connector.
- b) Polarizer which is made of soft material and susceptible to flaw must be handled carefully.
- c) Protective film (Laminator) is applied on surface to protect it against scratches and dirt.
- d) Please following the tear off direction as figure 14-1 to remove the protective film as slowly as possible, so that electrostatic charge can be minimized.

14-2) Precautions in mounting

- a) When metal part of the TFT-LCD module (shielding lid and rear case) is soiled, wipe it with soft dry cloth.
- b) Wipe off water drops or finger grease immediately. Long contact with water may cause discoloration or spots.
- c) TFT-LCD module uses glass which breaks or cracks easily if dropped or bumped on hard surface. Please handle with care.
- d) Since CMOS LSI is used in the module. So take care of static electricity and earth yourself when handling.

14-3) Adjusting module

- a) Adjusting volumes on the rear face of the module have been set optimally before shipment.
- b) Therefore, do not change any adjusted values. If adjusted values are changed, the specifications described may not be satisfied.

14-4) Others

- a) Do not expose the module to direct sunlight or intensive ultraviolet rays for many hours.
- b) Store the module at a room temperature place.
- c) The voltage of beginning electric discharge may over the normal voltage because of leakage current from approach conductor by to draw lump read lead line around.
- d) If LCD panel breaks, it is possibly that the liquid crystal escapes from the panel. Avoid putting it into eyes or mouth. When liquid crystal sticks on hands, clothes or feet. Wash it out immediately with soap.
- e) Observe all other precautionary requirements in handling general electronic components.
- f) Please adjust the voltage of common electrode as material of attachment by 1 module.

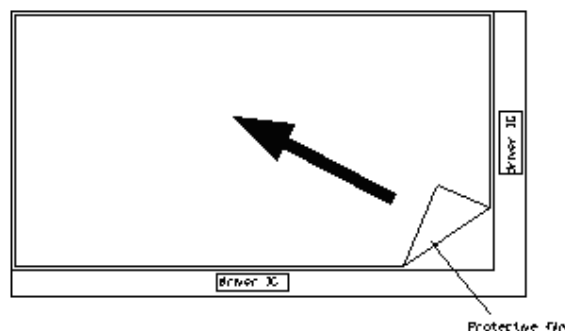

Figure 14-1 the way to peel off protective film

15. Reliability Test

No	Test Item	Test Condition
1	High Temperature Storage Test	Ta = +80°C, 240 hrs
2	Low Temperature Storage Test	Ta = -40°C, 240 hrs
3	High Temperature Operation Test	Ta = +70°C, 240 hrs
4	Low Temperature Operation Test	Ta = -30°C, 240 hrs
5	High Temperature & High Humidity Operation Test	Ta = 60°C, 90%RH, 240 hrs
6	Thermal Cycling Test (non-operating)	-30°C (0.5hour) → +70°C (0.5hour), 100Cycles
7	Vibration Test (non-operating)	Frequency : 10 ~ 57 Hz, Amplitude : 0.15 mm, 58~500Hz, 1G Sweep time: 11 min Test Period: 3 hrs (1 hr for each direction of X, Y, Z)
8	Shock Test (non-operating)	80G, 6ms, X, Y, Z 1 times for each direction
9	Electrostatic Discharge Test (Operation)	C=150pF, R=330Ω Contact=±8KV Air=±15KV 10 times/terminal

Ta: ambient temperature

[Criteria]

In the standard conditions, there is not display function NG issue occurred. (including : line defect ,no image). All the cosmetic specification is judged before the reliability stress.

