

KBPC2500~2510

Description

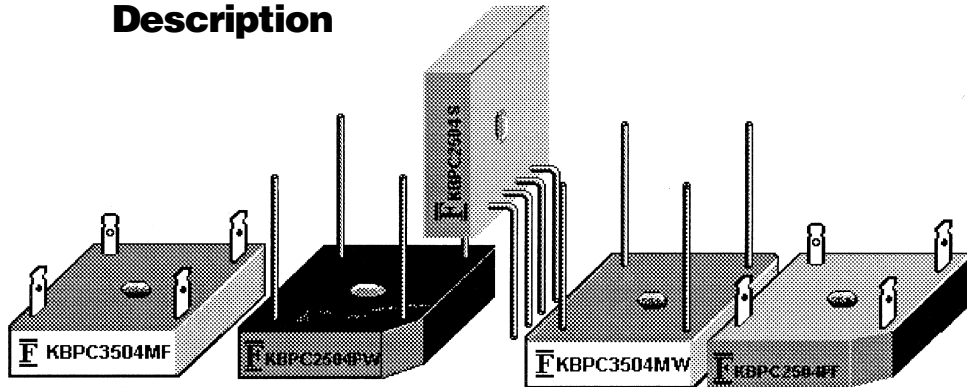

KBPC

Features

Surge overload ratings to 300 amperes
 This series is UL listed under the Recognized Component Index, file number E142814
 The plastic material used carries Underwriters Laboratory flammability recognition 94V-0
 Universal 4-way terminals, snap-on, wrap-around, solder or P.C. Board mounting
 High temperature soldering guaranteed 265 C/10 seconds at 5 lbs (2.3kg) tension

Mechanical Data

Case: Metal case
 Terminals: Plated .25" (6.53mm) Faston
 Mounting Position: Bolt down on heat-sink with silicone thermal compound between bridges and mounting surface for maximum heat transfer efficiency
 Mounting Position: Any
 Weight: 1.024 ounce, 29 grams (approx)

Maximum Ratings & Thermal Characteristics

Rating at 25°C ambient temperature unless otherwise specified, Resistive or Inductive load, 60 Hz.
 For Capacitive load derate current by 20%.

Parameter	Symbol	KBPC 2500	KBPC 2501	KBPC 2502	KBPC 2504	KBPC 2506	KBPC 2508	KBPC 2510	unit
Maximum repetitive peak reverse voltage	VRRM	50	100	200	400	600	800	1000	V
Maximum RMS bridge input voltage	VRMS	35	70	140	280	420	560	700	V
Maximum DC blocking voltage	VDC	50	100	200	400	600	800	1000	V
Maximum average forward rectified output current at TA=55°C	IF(AV)	25							A
Peak forward surge current single sine-wave superimposed on rated load (JEDEC Method)	IFSM	300							A
Rating for fusing (t<8.3ms)	I ² t	374							A ² sec
Typical thermal resistance per element (1)	ReJA	2.1							°C / W
Isolation voltage from case to leads	VIS	2500							Vac
Operating junction and storage temperature range	TJ, TSTG	-55 to + 150							°C

Electrical Characteristics

Rating at 25°C ambient temperature unless otherwise specified. Resistive or Inductive load, 60Hz.
 For Capacitive load derate by 20 %.

Parameter	Symbol	KBPC 2500	KBPC 2501	KBPC 2502	KBPC 2504	KBPC 2506	KBPC 2508	KBPC 2510	Unit
Maximum instantaneous forward voltage drop per leg at 12.5A	VF	1.0							V
Maximum DC reverse current at rated DC blocking voltage per element <small>TA =25°C TA =125°C</small>	IR	10 500							μA

Notes: (1)Thermal resistance from Junction to Ambient on P.C.board mounting.

Rating and Characteristic Curves ($T_A=25^{\circ}\text{C}$ Unless otherwise noted)
KBPC2500 thru KBPC2510

Fig. 1 Derating Curve for Output Rectified Current

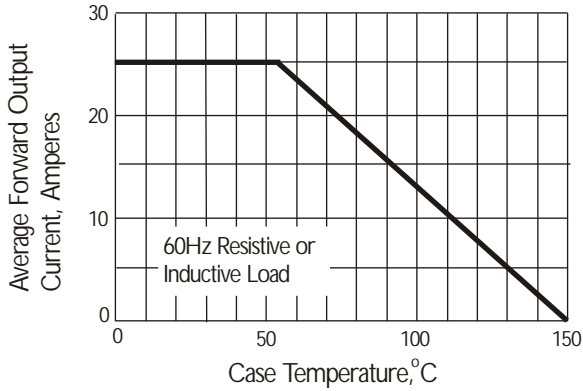

Fig. 2 Maximum Non-repetitive Peak Forward Surge Current

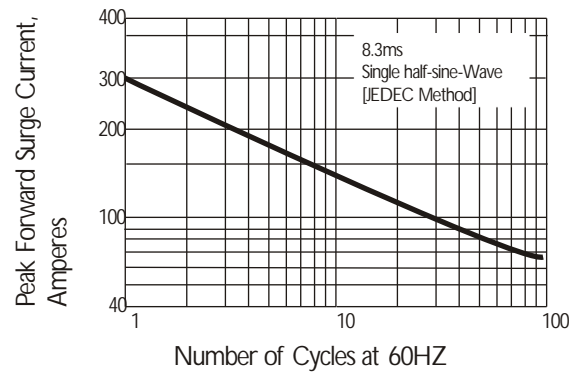

Fig. 3 Typical Instantaneous Forward Characteristics

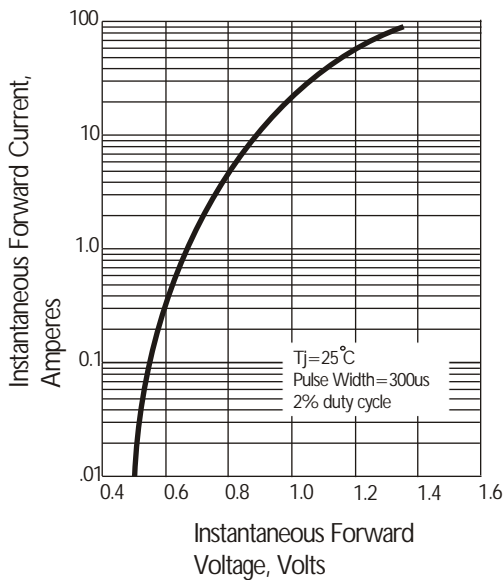
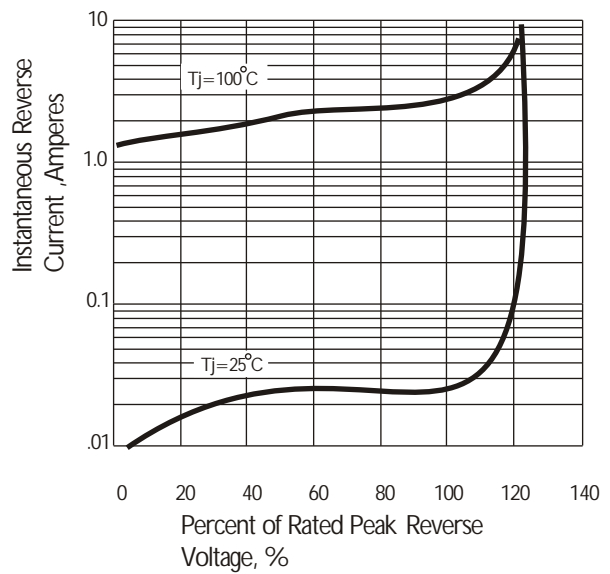
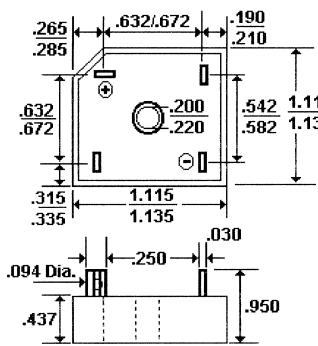

Fig. 4 Typical Reverse Characteristics at $T_J=25^{\circ}\text{C}$



KBPC2500~2510



Plastic Case/Fastons

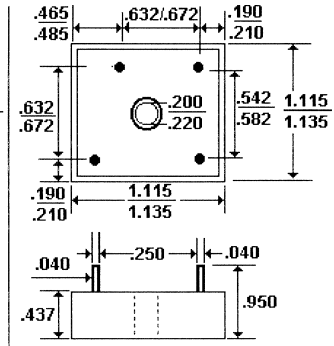

Metal Case/Wire Leads

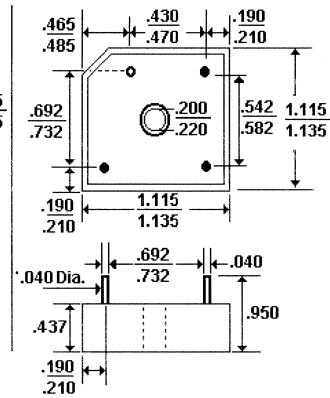

Plastic Case/Wire Leads

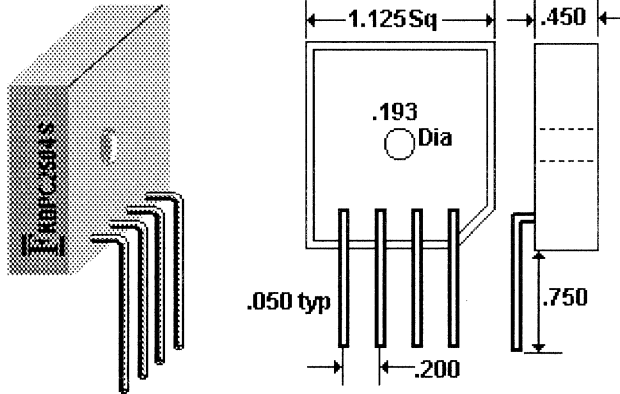

Ratings at
25 Deg. C ambient
temperature
unless otherwise
specified.

Single Phase Half
Wave, 60 HZ
Resistive or
Inductive Load.

For Capacitive
Load, Derate
Current by 20%.

- NOTES:**
1. Corrosion-Resistant Terminals Designed for .250" Female Quick Connect Wrap Around or Solder.
 2. A Thin Film of Silicone Thermal Compound is Recommended Between Bridge and Mounting Surface for Improved Thermal Conduction.
 3. These FCI Bridges Are Also Available in Fast Recovery, In Positive and Negative Center Tap and in Double Configurations. Consult with FCI for Your Special Requirements.

KBPC2500~2510

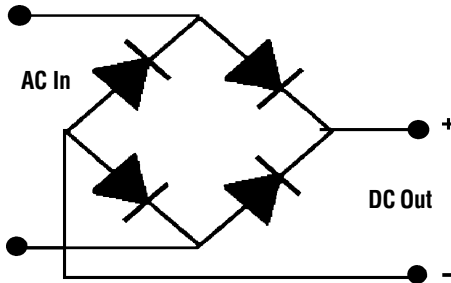

Case - Metal or Molded Plastic

Terminals - Plated .25" Faston or Plated Copper Wire Leads .040" Diameter

Weight - 0.706 Ounces, 20 Grams

Mounting Position - Any with Bolt Down with Silicone Thermal Compound Between Bridge and Mounting Surface for Optimum Heat

Transfer

Mounting Torque - 20 Inch Pound Max

Ordering Information

FCI'S KBPC Series of Bridges Can Be Ordered with Options on Terminals and Case Materials.

How To Specify Case Material and Terminal Options:

- For Metal Case, Order Suffix (1) "M"
- For Plastic Case, Order Suffix (1) "P"
- For Faston Terminals, Order Suffix (2) "F"
- For Wire Lead Terminals, Order Suffix (2) "W"

KBPC Series Examples

To Order a 25 Amp, 400 Volt Bridge with Faston Leads and a Plastic Case:

Specify - **KBPC2504PF** . . . Where "P" = Plastic and "F" = Faston Terminals

To Order a 35 Amp, 800 Volt Bridge with Wire Leads and a Metal Case:

Specify - **KBPC3508MW** . . . Where "M" = Metal and "W" = Wire Leads (Terminals)

To Order a 15 Amp, 200 Volt, UL Recognized Bridge with Wire Leads and a Plastic Case:

Specify - **KBPC1502PWU** . . . Where "P" = Plastic and "W" = Wire Leads (Terminals) and "U" = UL Recognized

NOTE: Fast Recovery Bridges (Diodes) Are Available; Please Contact FCI Components.

KBPC - "S" Series Examples

To Order Bridges with the "In-Line" Pin Configuration, Select the Current and Voltage Desired and Add "S" as the Suffix, as shown in the following example.

To Order a 35 Amp, 800 Volt Bridge with In-Line Wire Leads:

Specify - **KBPC3508S** . . . Where "S" = In-Line Wire Lead Terminals