

TRIAC

SSG25C

T-25-17

T104

For general A.C. power control applications such as A.C. switches, light controls, speed controls and heater controls etc.

- General A.C. power use
- $I_{T(RMS)} = 25A$
- High voltage up to 1200V
- High surge current of 250A
- Package types; stud

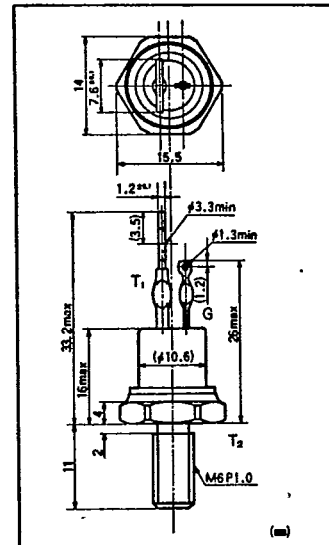
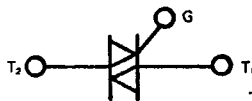

Maximum Ratings

Item	Symbol	Unit	SSG25C 20	SSG25C 30	SSG25C 40	SSG25C 50	SSG25C 60	SSG25C 80	SSG25C 100	SSG25C 120
Repetitive Peak Off-State Voltage	V_{DRM}	V	200	300	400	500	600	800	1000	1200

Item	Symbol	Unit	Rating	Reference
RMS On-State Current	$I_{T(RMS)}$	A	25	$T_c = 88^\circ C$
Surge On-State Current	I_{TSM}	A	220/250	One cycle 50/60Hz, peak, non-repetitive
I^2t (for fusing)	I^2t	A ² S	260	1 cycle
Peak Gate Power Dissipation	P_{GM}	W	10	
Average Gate Power Dissipation	$P_{G(AV)}$	W	1	
Peak Gate Current	I_{GM}	A	3	
Peak Gate Voltage	V_{GM}	V	10	
Critical Rate of Rise of On-State Current	di/dt	A/ μs	50	$I_c = 100mA$ $T_j = 25^\circ C$ $V_D = \frac{1}{2}V_{DRM}$ $dl_c/dt = 1A/\mu s$
Operating Junction Temperature	T_j	$^\circ C$	-30~+125	
Storage Temperature	T_{stg}	$^\circ C$	-30~+125	
Mounting Torque		kgf·cm	15	Recommended 12kgf·cm
Mass		g	13.6	Excluding nut & washer. 2.6g. and wrapping material 3g

Electrical Characteristics

Item	Symbol	Unit	Rating	Reference
Repetitive Peak Off-State Current, max.	I_{DRM}	mA	5	at V_{DRM} . Single phase, half wave
Peak On-State Voltage, max.	V_{TM}	V	1.6	$I_T = 35A$ $T_j = 25^\circ C$ Inst. measurement
Gate Trigger Current, max.	1 I_{GT1}	mA	70	$T_j = 25^\circ C$ $I_T = 1A$ $V_D = 6V$
	2 I_{GT1}	mA	70	$T_j = 25^\circ C$ $I_T = 1A$ $V_D = 6V$
	3 I_{GT3}	mA	—	
	4 I_{GT3}	mA	70	$T_j = 25^\circ C$ $I_T = 1A$ $V_D = 6V$
Gate Trigger Voltage, max.	1 V_{GT1}	V	3	$T_j = 25^\circ C$ $I_T = 1A$ $V_D = 6V$
	2 V_{GT1}	V	3	$T_j = 25^\circ C$ $I_T = 1A$ $V_D = 6V$
	3 V_{GT3}	V	—	
	4 V_{GT3}	V	3	$T_j = 25^\circ C$ $I_T = 1A$ $V_D = 6V$
Non-Trigger Gate Voltage, min.	V_{GD}	V	0.2	$T_j = 125^\circ C$ $V_D = \frac{1}{2}V_{DRM}$
Turn On Time, max.	t_{gt}	μs	10	$I_T = 25A$ $I_c = 100mA$ $V_D = \frac{1}{2}V_{DRM}$ $T_j = 25^\circ C$ $dl_c/dt = 1A/\mu s$
Critical Rate of Rise of Off-State Voltage, min.	dv/dt	V/ μs	100	$T_j = 125^\circ C$, $V_D = \frac{2}{3}V_{DRM}$ Exponential wave.
Critical Rate of Rise of Off-State Voltage at Commutation, min.	$(dv/dt)_c$	V/ μs	20	$T_j = 125^\circ C$, $(di/dt)_c = 15A/ms$, $V_D = \frac{2}{3}V_{DRM}$
Holding Current, typ.	I_H	mA	30	$T_j = 25^\circ C$
Thermal Impedance, max.	R_{th}	$^\circ C/W$	1.0	Junction to case

T-25-17

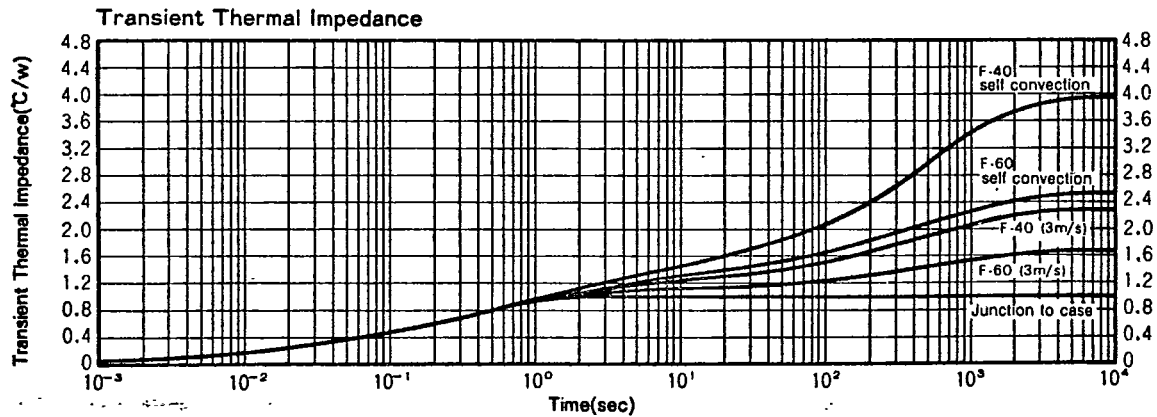
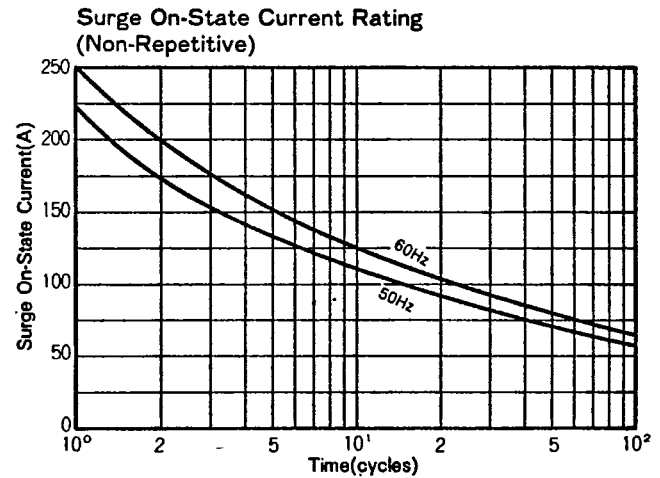
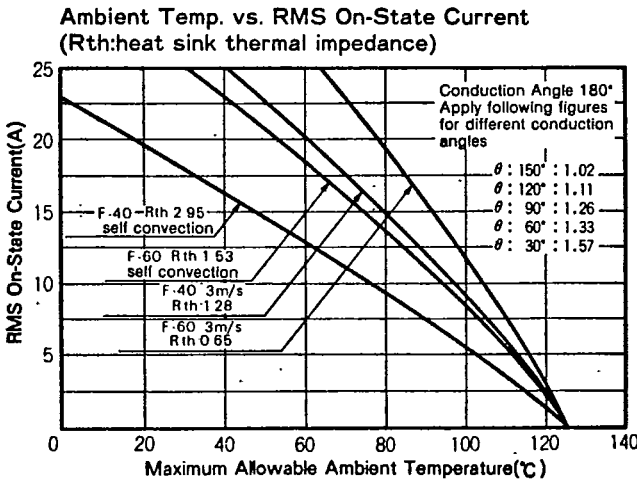
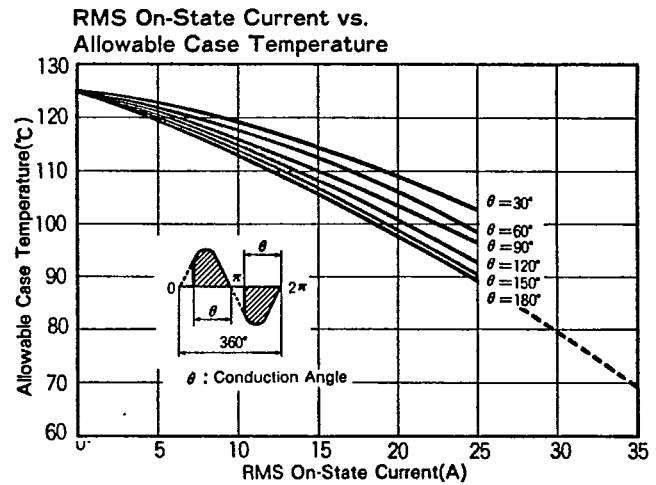
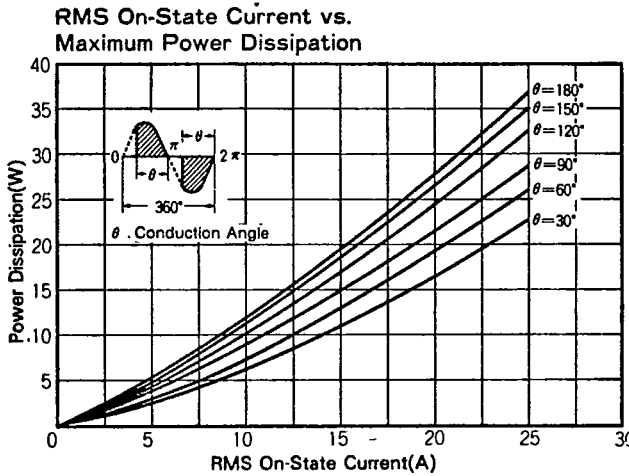
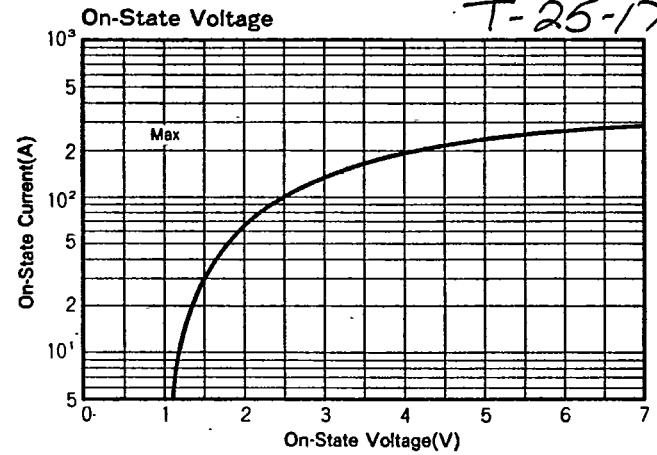
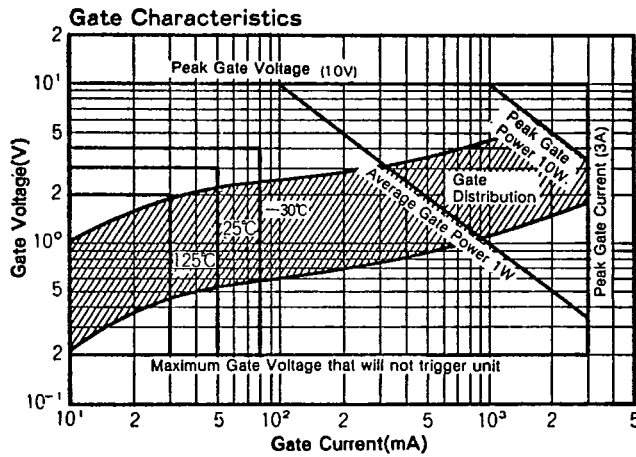

DIMENSIONS

IT IS FOR YOUR REFERENCE.
PLEASE SEE INDIVIDUAL CATALOG OR SPECIFICATIONS FOR FURTHER DETAILS.

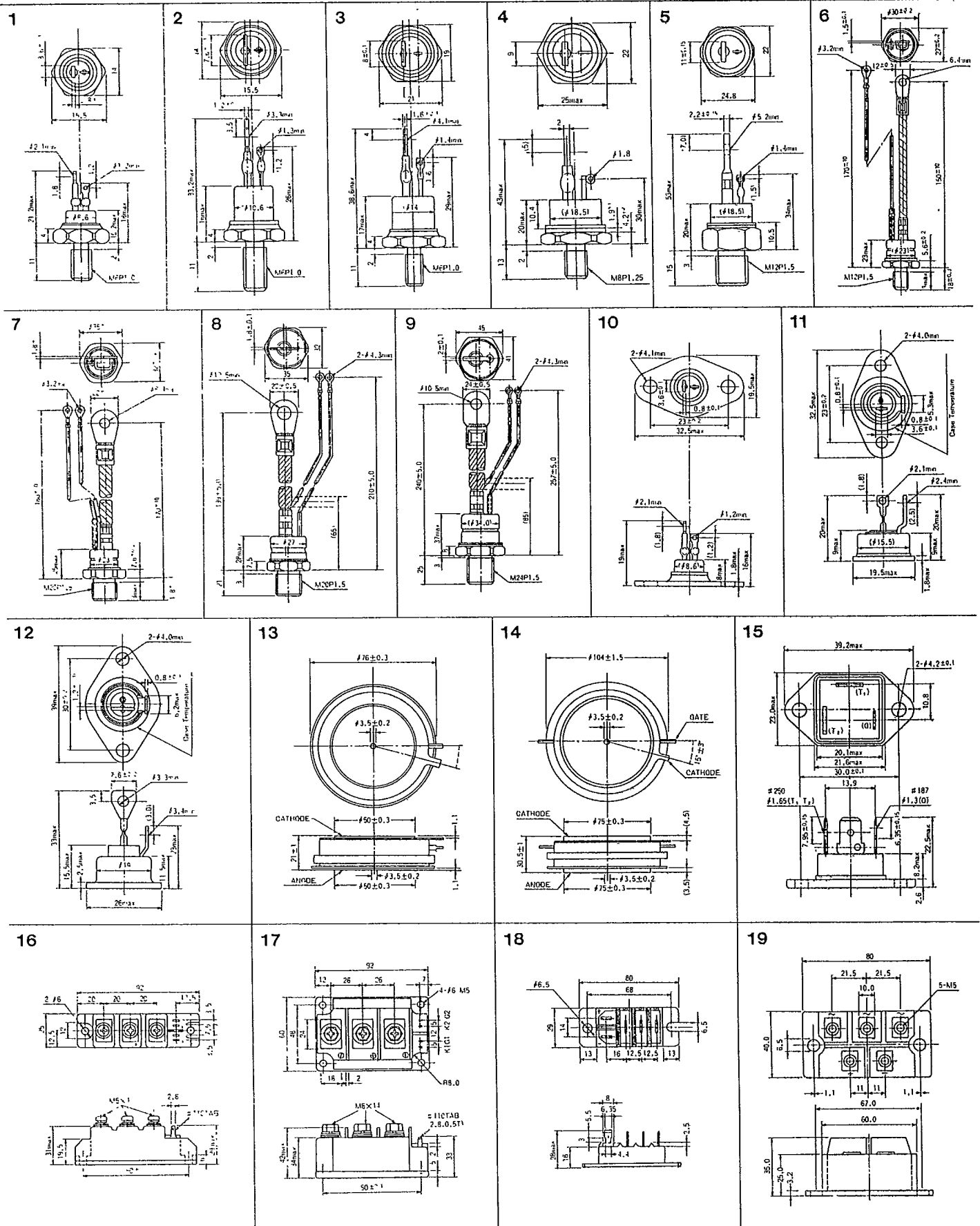

SanRex®

DIMENSIONS

DIMENSIONS

(m/m)

