



Programmable Peripheral PSD3XX Family Field-Programmable Microcontroller Peripheral

Key Features

- Single Chip Programmable Peripheral for Microcontroller-based Applications
- Wide Operating Voltage Range
 - L-Versions: 3.0 to 5.5 volts
 - Others: 4.5 to 5.5 volts
- 19 Individually Configurable I/O pins that can be used as
 - Microcontroller I/O port expansion
 - Programmable Address Decoder (PAD) I/O
 - Latched address output
 - Open drain or CMOS
- Two Programmable Arrays (PAD A and PAD B)
 - Total of 40 Product Terms and up to 16 Inputs and 24 Outputs
 - Address Decoding up to 1 MB
 - Logic replacement of discrete PALs®
- “No Glue” Microcontroller Chip-Set
 - Built-in address latches for multiplexed address/data bus
 - Non-multiplexed address/data bus mode
 - ALE and Reset (non-PSD3XXL versions) polarity programmable
 - Selectable modes for read and write control bus as $\overline{RD}/\overline{WR}$ or $R/\overline{W}/E$
- 256K to 2 MBits of UV EPROM (2 Mbit version is SRAMless)
 - Configurable as 32, 64, 128 or 256K x 8 or as 16, 32, 64 or 128K x 16
 - Divides into 8 equal mappable blocks for optimized mapping
 - Block resolution is 4K x 8 or 2K x 16 (PSD3X1) to 32K x 8 or 16K x 16 (PSD3X4R)
 - As fast as 70 ns EPROM access time, including input latches and PAD address decoding.
- 16 Kbit Static RAM (No SRAM on PSD3XXR versions)
 - Configurable as 2K x 8 or as 1K x 16
 - As fast as 70 ns SRAM access time, including input latches and PAD address decoding
- Built-in Page Logic (PSD3X2/3X3/3X4R)
 - Expands the MCU address space up to sixteen 1 Mb pages
- CMiser Bit
 - Programmable option to further reduce power consumption
- Address/Data Track Mode
 - Enables easy Interface to Shared Resources (Mail Box SRAM) with other Microcontrollers or a Host Processor
- Built-In Security
 - Locks the device and PAD Decoding configuration

Key Features

(Cont.)

- Available in a Variety of Packaging
 - 44 Pin PLDCC, CLDCC, PQFP, TQFP, and CPGA
- Simple Menu-Driven Software: Configure the PSD3XX on an IBM PC
- PSD3XX standard versions are excellent for general purpose applications
- PSD3XXR SRAMless versions result in lower cost
- PSD3XXL versions (3.0 to 5.5 volt operation) eliminate mixing and matching discrete low-voltage parts
- PSD3XXM mask-programmable versions are ideal for code-stable, high-volume low cost applications

PSD3XX Family Feature Summary

<i>Part</i>	<i>PLD Inputs/Product Terms</i>	<i>Ports</i>	<i>EPROM Size</i>	<i>SRAM Size</i>	<i>Configuration</i>	<i>Memory Paging</i>	<i>C-Miser Bit</i>	<i>Security Bit</i>
PSD301 [®]	14/40	19	256 Kb	16 Kb	x8 or x16		X	X
PSD311	14/40	19	256 Kb	16 Kb	x8		X	X
PSD302	18/40	19	512 Kb	16 Kb	x8 or x16	X	X	X
PSD312	18/40	19	512 Kb	16 Kb	x8	X	X	X
PSD303	18/40	19	1 Mb	16 Kb	x8 or x16	X	X	X
PSD313	18/40	19	1 Mb	16 Kb	x8	X	X	X
PSD304R	18/40	19	2 Mb	—	x8 or x16	X	X	X
PSD314R	18/40	19	2 Mb	—	x8	X	X	X

Partial Listing of Microcontrollers Supported

- Motorola family:** M6805, M68HC11, M68HC16, M68000/10/20, M60008, M683XX
- Intel family:** 8031/8051, 8096/8098, 80186/88, 80196/98
- Philips Semiconductors:** SC80C451, SC80552
- TI:** SC80C451, TMS320C14
- Zilog:** Z8, Z80, Z180
- National:** HPC16000, HPC46400
- Echelon:** NEURON[®] 3150[™] Chip

Applications

- Computers (Notebook and Portable PCs)
 - Fixed Disk Control, Modem, Imaging, Laser Printer Control
- Telecommunications
 - Modem, Cellular Phone, Digital PBX, Digital Speech, FAX, Digital Signal Processing
- Portable Industrial Equipment
 - Measurement Instruments, Data Recorders
- Medical Instrumentation
 - Monitoring Equipment, Diagnostic Tools



Introduction

The PSD3XX family is the market's first single-chip solution for microcontroller-based applications where criteria such as fast time-to-market, small form factor, and low power consumption are essential. When combined in an 8- or 16-bit system, virtually any microcontroller (68HC11, 8031/8051, 80186, etc.) and the PSD3XX device work together to create a very powerful chip-set solution. The low-voltage PSD3XXL versions eliminate mixing and matching low voltage specifications for various discrete components. They also provide all the required control and peripheral elements needed in a microcontroller-based system with no external discrete "glue" logic required.

The PSD3XX family comes complete with simple system software development tools for interfacing the PSD3XX with a microcontroller. Hosted on an IBM PC platform or compatible, the easy to use PSDsoft software enables the designer to quickly configure the device and use it immediately.

PSD3XX standard versions are ideal for general purpose embedded control applications.

PSD3XXR (SRAM-less) versions are optimized for designs that either require no on-chip SRAM or require large off-chip SRAMs for data storage. (SRAM-less versions were formerly identified by a "C1" suffix to the part number.)

PSD3XXM mask-programmable versions deliver the lowest cost PSD3XX solution. See the Masked-PSD Ordering Information chapter in this databook for the mask-programmable PSD3XXM ordering procedure.

PSD3XXL low-power versions operate down to 3.0 volts and feature standby current of only 1 μ A typical.

Combinations of the above versions are available. See the ordering information section at the end of this data sheet.

References in this document to PSD3XX versions include any "Non-L" products (e.g., PSD3XX, PSD3XXR, PSD3XXM and PSD3XXRM). References to PSD3XXR include any SRAM-less product (PSD3XXR, PSD3XXRM, PSD3XXRL and PSD3XXRLM). References to PSD3XXM include PSD3XXM, PSD3XXRM, PSD3XXLM, and PSD3XXRLM products. References to PSD3XXL include PSD3XXL, PSD3XXLM, PSD3XXRL and PSD3XXRLM products.

Revisions

Product Revisions	Revision Reason	Data Sheet Changes
Original PSD3XX	Initial release	–
Revision A PSD3XX-A	Design changed for improved manufacturability and improved margin to specification.	None

See page 1-15 for general description of product numbering.

Product Description

The PSD3XX family integrates high performance user-configurable blocks of EPROM, SRAM, and programmable logic. The major functional blocks include two programmable logic arrays, PAD A and PAD B, 256K to 2Mbit of EPROM, 16K bits of SRAM (no SRAM on PSD3XXR versions), input latches, and output ports. The PSD3XX family is ideal for applications requiring low power and very small form factors. These include hard disk control, modems, cellular telephones, instrumentation, computer peripherals, military and similar applications.

The PSD3XX family offers a unique single-chip solution for microcontrollers that need:

- I/O reconstruction (microcontrollers lose at least two I/O ports when accessing external resources).
- More EPROM and SRAM than the microcontroller's internal memory.
- 3.3 volt system operation (PSD3XXL versions).
- Chip-select, control, or latched address lines that are otherwise implemented discretely.
- An interface to shared external resources.
- Expanded microcontroller address space.

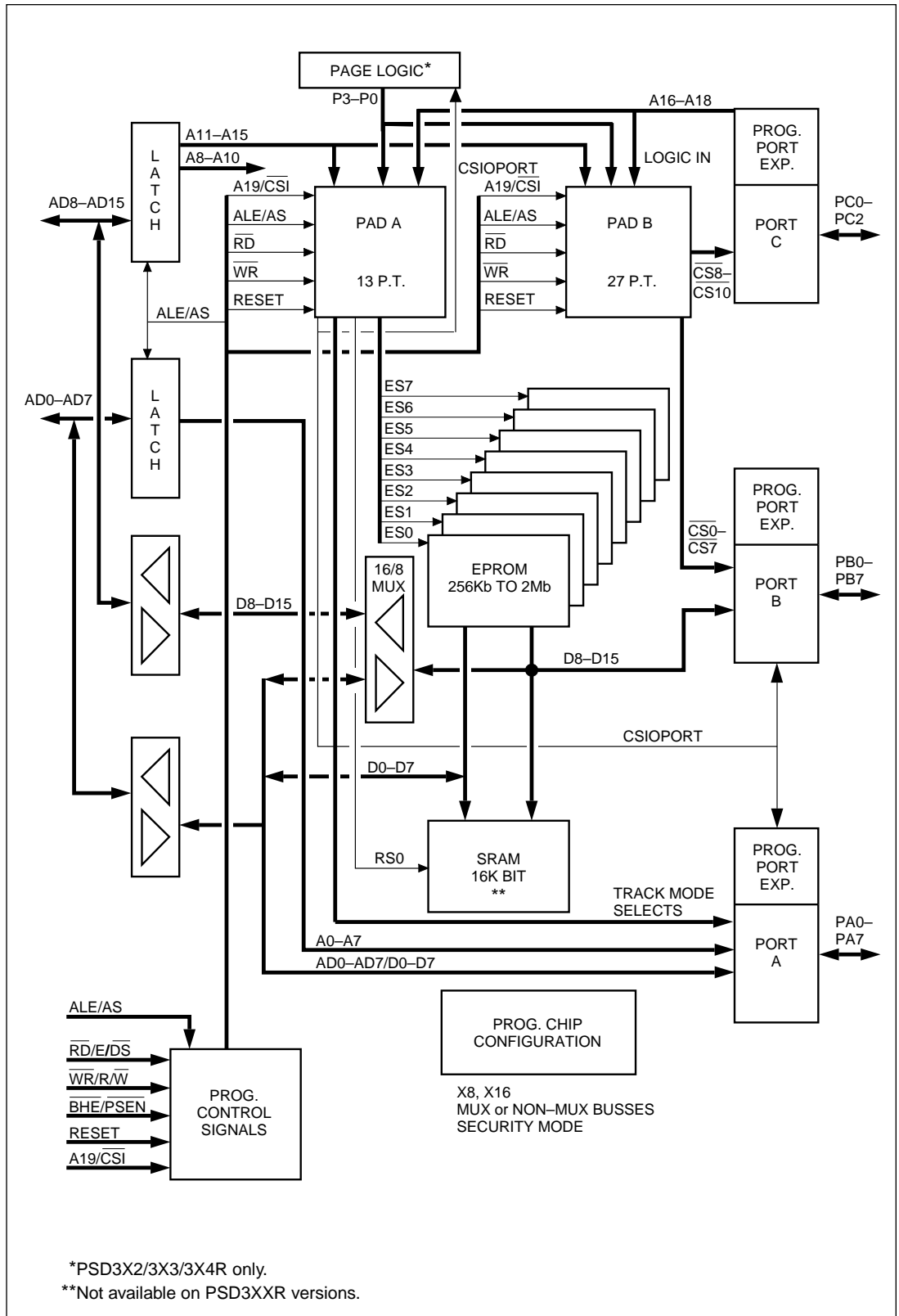
WSI's PSD3XX Family Architecture (Figure 1) can efficiently interface with, and enhance, any low-voltage 8- or 16-bit microcontroller system. This is the first solution that provides microcontrollers with port expansion, latched addresses, page logic, two programmable logic arrays (PAD A and PAD B), an interface to shared resources, 256K, 512K, 1M, or 2Mbit EPROM, and 16K bit SRAM on a single chip. The PSD3XX family does not require any glue logic for interfacing to any 8- or 16-bit microcontroller.

The 8051 microcontroller family can take full advantage of the PSD3XX's separate program and data address spaces. Users of the 68HCXX microcontroller family can change the functionality of the control signals and directly connect the R/\overline{W} and E , or the R/\overline{W} and DS signals. (Users of 16-bit microcontrollers, including the 80186, 8096, 80196 and 16XXX, can use the PSD301/302/303 in a 16-bit configuration). Address and data buses can be configured as separate or multiplexed, whichever is required by the host processor.

The flexibility of the PSD3XX I/O ports permits interfacing to shared resources. The arbitration can be controlled internally by PAD A outputs. The user can assign the following functions to these ports: standard I/O pins, chip-select outputs from PAD A and PAD B, or latched address or multiplexed low-order address/data byte. This enables users to design add-on systems such as disk drives, modems, etc., that easily interface to the host bus (e.g., IBM PC, SCSI).

The page register extends the accessible address space of certain microcontrollers from 64 K to 1 M. There are 16 pages that can serve as base address inputs to the PAD, thereby enlarging the address space of 16 address line microcontrollers by a factor of 16.

Figure 1.
PSD3XX
Family
Architecture



**Table 1.
PSD3XX Pin
Descriptions**

Name	Type	Description																														
$\overline{\text{BHE}}/\overline{\text{PSEN}}$ (PSD30X Devices) or $\overline{\text{PSEN}}$ (PSD31X Devices Only)	I	<p>When the data bus width is 8 bits (CDATA = 0), this pin is $\overline{\text{PSEN}}$. In this mode, $\overline{\text{PSEN}}$ is the active low EPROM read pulse. The SRAM and I/O ports read signal is generated according to the description of the $\overline{\text{WR}}/\overline{\text{V}}_{\text{PP}}$ or $\overline{\text{R}}/\overline{\text{W}}$ and $\overline{\text{RD}}/\overline{\text{E}}/\overline{\text{DS}}$ pins. If the host processor is a member of the 8031 family, $\overline{\text{PSEN}}$ must be connected to the corresponding host pin. In other 8-bit host processors that do not have a special EPROM-only read strobe, $\overline{\text{PSEN}}$ should be tied to V_{CC}. In this case, $\overline{\text{RD}}$ or E and $\overline{\text{R}}/\overline{\text{W}}$ provide the read strobe for the SRAM, I/O ports, and EPROM. When the data bus width is configured as 16 (CDATA = 1), this pin is $\overline{\text{BHE}}$. When $\overline{\text{BHE}}$ is low, data bus bits D8–D15 are read from, or written into, the PSD3XX, depending on the operation being read or write, respectively. In programming mode, this pin is pulsed between V_{PP} and 0.</p> <p>The $\overline{\text{PSEN}}$ is the active low EPROM read pulse. The SRAM and I/O ports read signal is generated according to the description of the $\overline{\text{WR}}/\overline{\text{V}}_{\text{PP}}$ or $\overline{\text{R}}/\overline{\text{W}}$, and $\overline{\text{RD}}/\overline{\text{E}}$ pins. If the host processor is a member of the 8031 family, $\overline{\text{PSEN}}$ must be connected to the corresponding host pin. In other 8-bit host processors that do not have a special EPROM-only read strobe, $\overline{\text{PSEN}}$ should be tied to V_{CC}. In this case, $\overline{\text{RD}}$ or E and $\overline{\text{R}}/\overline{\text{W}}$ provide the read strobe for the SRAM, I/O ports, and EPROM.</p>																														
$\overline{\text{WR}}/\overline{\text{V}}_{\text{PP}}$ or $\overline{\text{R}}/\overline{\text{W}}/\overline{\text{V}}_{\text{PP}}$	I	<p>In the operating mode this pin's function is $\overline{\text{WR}}$ (CRRWR = 0) or $\overline{\text{R}}/\overline{\text{W}}$ (CRRWR = 1). When configured as $\overline{\text{R}}/\overline{\text{W}}$, the following tables summarize the read and write operations (CRRWR = 1):</p> <table border="1" data-bbox="699 1016 1328 1184"> <thead> <tr> <th colspan="3">CEDS = 0</th> <th colspan="3">CEDS = 1 (Note 2)</th> </tr> <tr> <th>$\overline{\text{R}}/\overline{\text{W}}$</th> <th>E</th> <th></th> <th>$\overline{\text{R}}/\overline{\text{W}}$</th> <th>$\overline{\text{DS}}$</th> <th></th> </tr> </thead> <tbody> <tr> <td>X</td> <td>0</td> <td>NOP</td> <td>X</td> <td>1</td> <td>NOP</td> </tr> <tr> <td>0</td> <td>1</td> <td>write</td> <td>0</td> <td>0</td> <td>write</td> </tr> <tr> <td>1</td> <td>1</td> <td>read</td> <td>1</td> <td>0</td> <td>read</td> </tr> </tbody> </table> <p>When configured as $\overline{\text{WR}}$, a write operation is executed during an active low pulse. When configured as $\overline{\text{R}}/\overline{\text{W}}$, with $\overline{\text{R}}/\overline{\text{W}} = 1$ and E = 1, a read operation is executed; if $\overline{\text{R}}/\overline{\text{W}} = 0$ and E = 1, a write operation is executed. In programming mode, this pin must be tied to V_{PP} voltage.</p>	CEDS = 0			CEDS = 1 (Note 2)			$\overline{\text{R}}/\overline{\text{W}}$	E		$\overline{\text{R}}/\overline{\text{W}}$	$\overline{\text{DS}}$		X	0	NOP	X	1	NOP	0	1	write	0	0	write	1	1	read	1	0	read
CEDS = 0			CEDS = 1 (Note 2)																													
$\overline{\text{R}}/\overline{\text{W}}$	E		$\overline{\text{R}}/\overline{\text{W}}$	$\overline{\text{DS}}$																												
X	0	NOP	X	1	NOP																											
0	1	write	0	0	write																											
1	1	read	1	0	read																											
$\overline{\text{RD}}/\overline{\text{E}}/\overline{\text{DS}}$ (Note 2) or $\overline{\text{RD}}/\overline{\text{E}}$ (Note 3)	I	<p>The pin function depends on the CRRWR and CEDS configuration bits. If CRRWR = 0, $\overline{\text{RD}}$ is an active low read pulse. When CRRWR = 1, this pin and the $\overline{\text{R}}/\overline{\text{W}}$ pin define the following cycle type: If CEDS = 0, E is an active high strobe. If CEDS = 1, $\overline{\text{DS}}$ is an active low strobe.</p> <p>When configured as $\overline{\text{RD}}$ (CRRWR = 0), this pin provides an active low $\overline{\text{RD}}$ strobe. When configured as E (CRRWR = 1), this pin becomes an active high pulse, which, together with $\overline{\text{R}}/\overline{\text{W}}$ defines the cycle type. Then, if $\overline{\text{R}}/\overline{\text{W}} = 1$ and E = 1, a read operation is executed. If $\overline{\text{R}}/\overline{\text{W}} = 0$ and E = 1, a write operation is executed.</p>																														

Legend: The I/O column abbreviations are: I = input; I/O = input/output; P = power.

- NOTE:**
1. All the configuration bits mentioned in Table 1 appear in parentheses and are explained in the Configuration Register section.
 2. PSD3X2/3X3/3X4R only.
 3. PSD3X1 only.



Table 1.
PSD3XX Pin
Descriptions
(Cont.)

Name	Type	Description
A19/ $\overline{\text{CS}}_1$	I	This pin has two configurations. When it is $\overline{\text{CS}}_1$ (A19/ $\overline{\text{CS}}_1 = 0$) and the pin is asserted high, the device is deselected and powered down. (See Tables 12 and 13 for the chip state during power-down mode.) If the pin is asserted low, the chip is in normal operational mode. When it is configured as A19, (A19/ $\overline{\text{CS}}_1 = 1$), this pin can be used as an additional input to the PAD. CADLOG3 = 1 (CATD = 1 for PSD3X1) defines the pin as an address; CADLOG3 = 0 (CATD = 0 for PSD3X1) defines it as a logic input. If it is an address, A19 can be latched with ALE (CADDHLT = 1) or be a transparent logic input (CADDHLT = 0). In this mode, there is no power-down capability.
RESET	I	This user-programmable pin can be configured to reset on high level (CRESET = 1) or on low level (CRESET = 0). It should remain active for at least 100 ns. See Tables 10 and 11 and Figure 11 for reset details.
ALE or AS	I	In the multiplexed modes, the ALE pin functions as an Address Latch Enable or as an Address strobe and can be configured as an active high or active low signal. The ALE or AS trailing edge latches lines AD15/A15–AD0/A0 and A16–A19 in 16-bit mode (AD7/A7–AD0/A0 and A16–A19 in 8-bit mode) and $\overline{\text{BHE}}$, depending on the PSD3XX configuration. See Table 8. In the non-multiplexed modes (PSD3X2/3X3), it can be used as a general-purpose logic input to the PAD.
PA7 PA6 PA5 PA4 PA3 PA2 PA1 PA0	I/O	PA7–PA0 is an 8-bit port that can be configured to track AD7/A7–AD0/A0 from the input (CPAF2 = 1). Otherwise (CPAF2 = 0), each bit can be configured separately as an I/O or lower-order latched address line. When configured as an I/O (CPAF1 = 0), the direction of the pin is defined by its direction bit, which resides in the direction register. If a pin is an I/O output, its data bit (which resides in the data register) comes out. When it is configured as a low-order address line (CPAF1 = 1), A7–A0 can be made the corresponding output through this port (e.g., PA6 can be configured to be the A6 address line). Each port bit can be a CMOS output (CPACOD = 0) or an open drain output (CPACOD = 1). When the chip is in non-multiplexed mode (CADDRAT = 0), the port becomes the data bus lines (D0–D7). See Figure 4.
PB7 PB6 PB5 PB4 PB3 PB2 PB1 PB0	I/O	PB7–PB0 is an 8-bit port for which each bit can be configured as an I/O (CPBF = 1) or chip-select output (CPBF = 0). Each port bit can be a CMOS output (CPBCOD = 0) or an open drain output (CPBCOD = 1). When configured as an I/O, the direction of the pin is defined by its direction bit, which resides in the direction register. If a pin is an I/O output, its data (which resides in the data register) comes out. When configured as a chip-select output, $\overline{\text{CS}}_0$ – $\overline{\text{CS}}_3$ are a function of up to four product terms of the inputs to the PAD B; $\overline{\text{CS}}_4$ – $\overline{\text{CS}}_7$ then are each a function of up to two product terms. On the PSD301/302/303, when the chip is in non-multiplexed mode (CADDRAT = 0) and the data bus width is 16 (CDATA = 1), the port becomes the data bus (D8–D15). See Figure 6.

Table 1.
PSD3XX Pin
Descriptions
(Cont.)

Name	Type	Description
PC0 PC1 PC2	I/O	This is a 3-bit port for which each bit is configurable as a PAD A and B input or output. When configured as an input (CPCF = 0), a bit individually becomes an address (CADLOG = 1 for PSD3X2/3X3, CATD = 1 for PSD3X1) or a logic input (CADLOG = 0 for PSD3X2/3X3, CATD = 0 for PSD3X1). The addresses can be latched with ALE (CADDHLT = 1) or be transparent inputs to the PADs (CADDHLT = 0). When a pin is configured as an output (CPCF = 1), it is a function of one product term of all PAD inputs. See Figure 7.
AD0/A0 AD1/A1 AD2/A2 AD3/A3 AD4/A4 AD5/A5 AD6/A6 AD7/A7	I/O	In multiplexed mode, these pins are the multiplexed low-order address/data byte. After ALE latches the addresses, these pins input or output data, depending on the settings of the \overline{RD}/E ($\overline{RD}/E/\overline{DS}$ on the PSD302/312/303/313), \overline{WR}/V_{PP} or R/\overline{W} , and $\overline{BHE}/\overline{PSEN}$ pins. In non-multiplexed mode, these pins are the low-order address input.
AD8/A8 AD9/A9 AD10/A10 AD11/A11 AD12/A12 AD13/A13 AD14/A14 AD15/A15	I/O	In 16-bit multiplexed mode, these pins are the multiplexed high-order address/data byte. After ALE latches the addresses, these pins input or output data, depending on the settings of the \overline{RD}/E or $\overline{RD}/E/\overline{DS}$, \overline{WR}/V_{PP} or R/\overline{W} , and $\overline{BHE}/\overline{PSEN}$ pins. In all other modes, these pins are the high-order address input.
GND	P	V_{SS} (ground) pin.
V_{CC}	P	Supply voltage input.

Operating Modes

The PSD3XX's four operating modes enable it to interface directly to 8- and 16-bit microcontrollers with multiplexed and non-multiplexed address/data buses. These operating modes are:

- Multiplexed 8-bit address/data bus
- Multiplexed 16-bit address/data bus (PSD30X)
- Non-multiplexed address/data, 8-bit data bus
- Non-multiplexed 16-bit address/data bus (PSD30X)

Multiplexed 8-bit Address/Data Bus

This mode is used to interface to microcontrollers with an 8-bit data bus and a 16-bit or larger address bus. The address/data bus (AD0/A0–AD7/A7) is bi-directional and permits the latching of the address when the ALE signal is active. On the same pins, the data is read from or written to the device; this depends on the state of the \overline{RD}/E or $\overline{RD}/E/\overline{DS}$ pin, $\overline{BHE}/\overline{PSEN}$ or \overline{PSEN} pin and \overline{WR}/V_{PP} or R/\overline{W} pins. The high-order address/data bus (AD8/A8–AD15/A15) contains the high-order address bus byte. Ports A and B can be configured as in Table 2.

Multiplexed 16-bit Address/Data Bus

This mode is used to interface to microcontrollers with a 16-bit data bus and a 16-bit or larger address bus. The low-order address/data bus (AD0/A0–AD7/A7) is bi-directional and permits the latching of the address when the ALE signal is active. On the same pins, the data is read from or written to the device; this depends on the state of the $\overline{RD}/E/\overline{DS}$, $\overline{BHE}/\overline{PSEN}$, and \overline{WR}/V_{PP} or R/\overline{W} pins. The high-order address/data bus (AD8/A8–AD15/A15) is bi-directional and permits latching of the high-order address when the ALE signal is active on the same pins. The high-order data bus is read from or written to the device, depending on the state of the $\overline{RD}/E/\overline{DS}$, $\overline{BHE}/\overline{PSEN}$, and \overline{WR}/V_{PP} or R/\overline{W} pins. Ports A and B can be configured as in Table 2.

Non-Multiplexed Address/Data, 8-bit Data Bus

This mode is used to interface to non-multiplexed 8-bit microcontrollers with an 8-bit data bus and a 16-bit or larger address bus. The low-order address/data bus (AD0/A0–AD7/A7) is the low-order address input bus. The high-order address/data bus (AD8/A8–AD15/A15) (A8–A15 on the PSD31X) is the high-order address bus byte. Port A is the low-order data bus. Port B can be configured as shown in Table 2.

Non-Multiplexed Address/Data, 16-bit Data Bus

This mode is used to interface to non-multiplexed 16-bit microcontrollers with a 16-bit data bus and a 16-bit or larger address bus. The low-order address/data bus (AD0/A0–AD7/A7) is the low-order address input bus. The high-order address/data bus (AD8/A8–AD15/A15) is the high-order address bus byte. Port A is the low-order data bus. Port B is the high-order data bus.

Table 2 summarizes the effect of the different operating modes on ports A, B, and the address/data pins. The configuration of Port C is independent of the four operating modes.



Figure 2a.
PSD3XX Port
Configurations
(x8/x16)

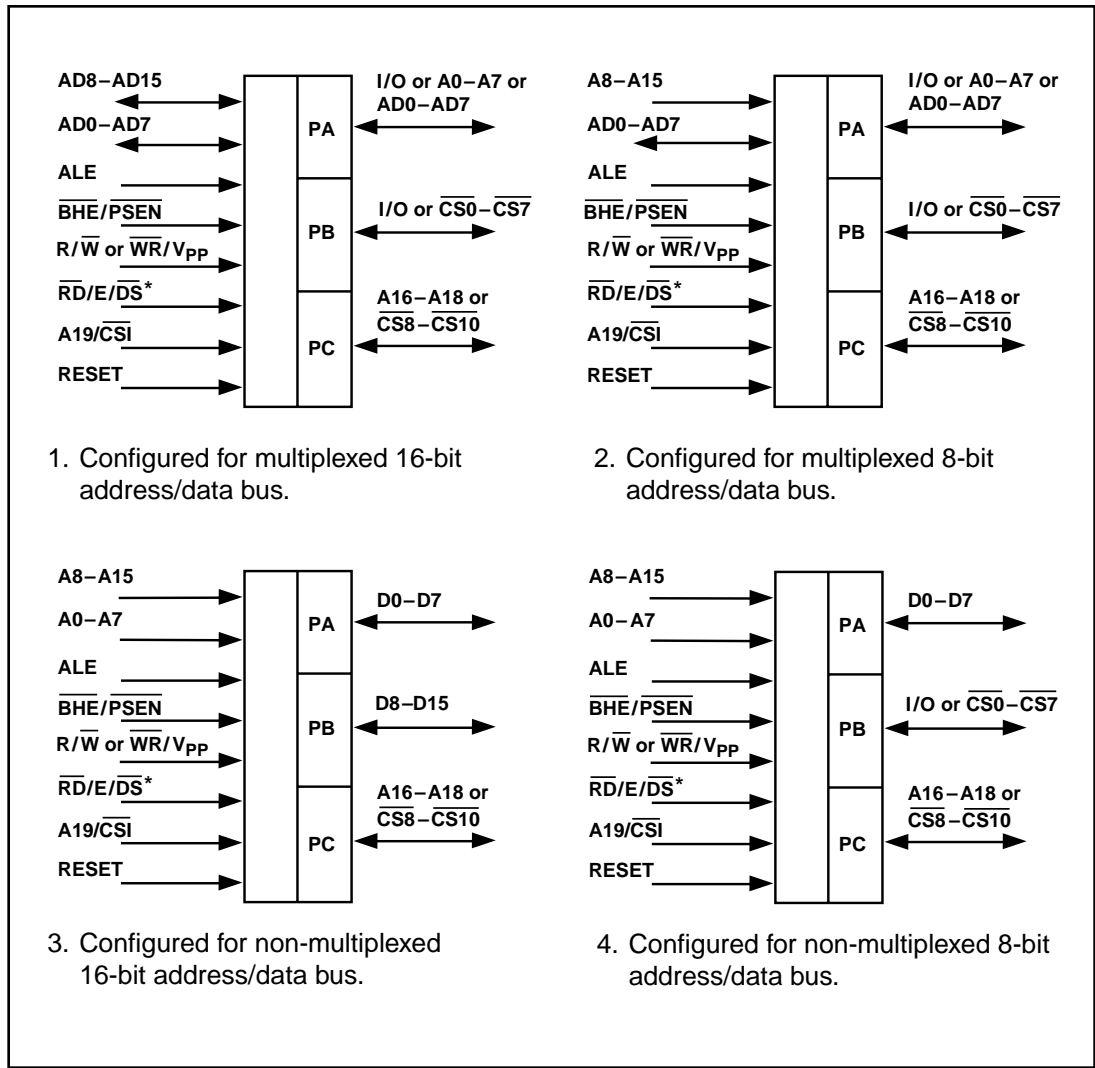
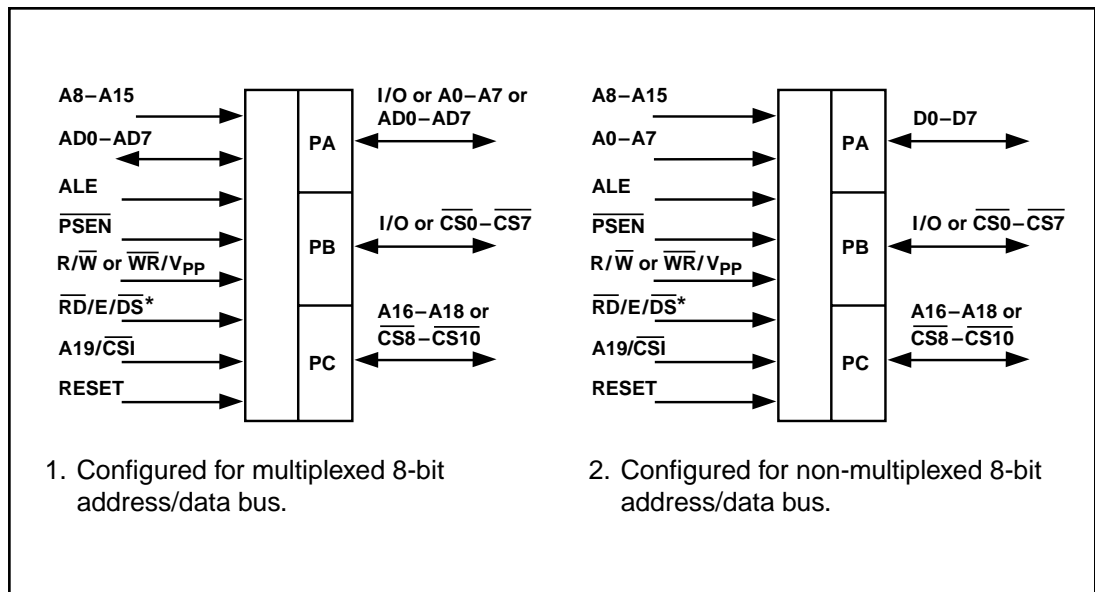


Figure 2b.
PSD31X Port
Configurations
(x8 Only)



Legend: AD8-AD15 = Addresses A8-A15 multiplexed with data lines D8-D15.
AD0-AD7 = Addresses A0-A7 multiplexed with data lines D0-D7.

* = DS is available on PSD3X2/3X3/3X4R only.



**Table 2.
PSD30X Bus
and Port
Configuration
Options**

	Multiplexed Address/Data	Non-Multiplexed Address/Data
8-bit Data Bus		
Port A	I/O or low-order address lines or low-order multiplexed address/data byte	D0–D7 data bus byte
Port B	I/O and/or $\overline{CS0}$ – $\overline{CS7}$	I/O and/or $\overline{CS0}$ – $\overline{CS7}$
AD0/A0–AD7/A7	Low-order multiplexed address/data byte	Low-order address bus byte
AD8/A8–AD15/A15	High-order multiplexed address data byte	High-order address bus byte
16-bit Data Bus		
Port A	I/O or low-order address lines or low-order multiplexed address/data byte	Low-order data bus byte
Port B	I/O and/or $\overline{CS0}$ – $\overline{CS7}$	High-order data bus byte
AD0/A0–AD7/A7	Low-order multiplexed address/data byte	Low-order address bus byte
AD8/A8–AD15/A15	High-order multiplexed address/data byte	High-order address bus byte

**Table 2a.
PSD31X Bus
and Port
Configuration
Options**

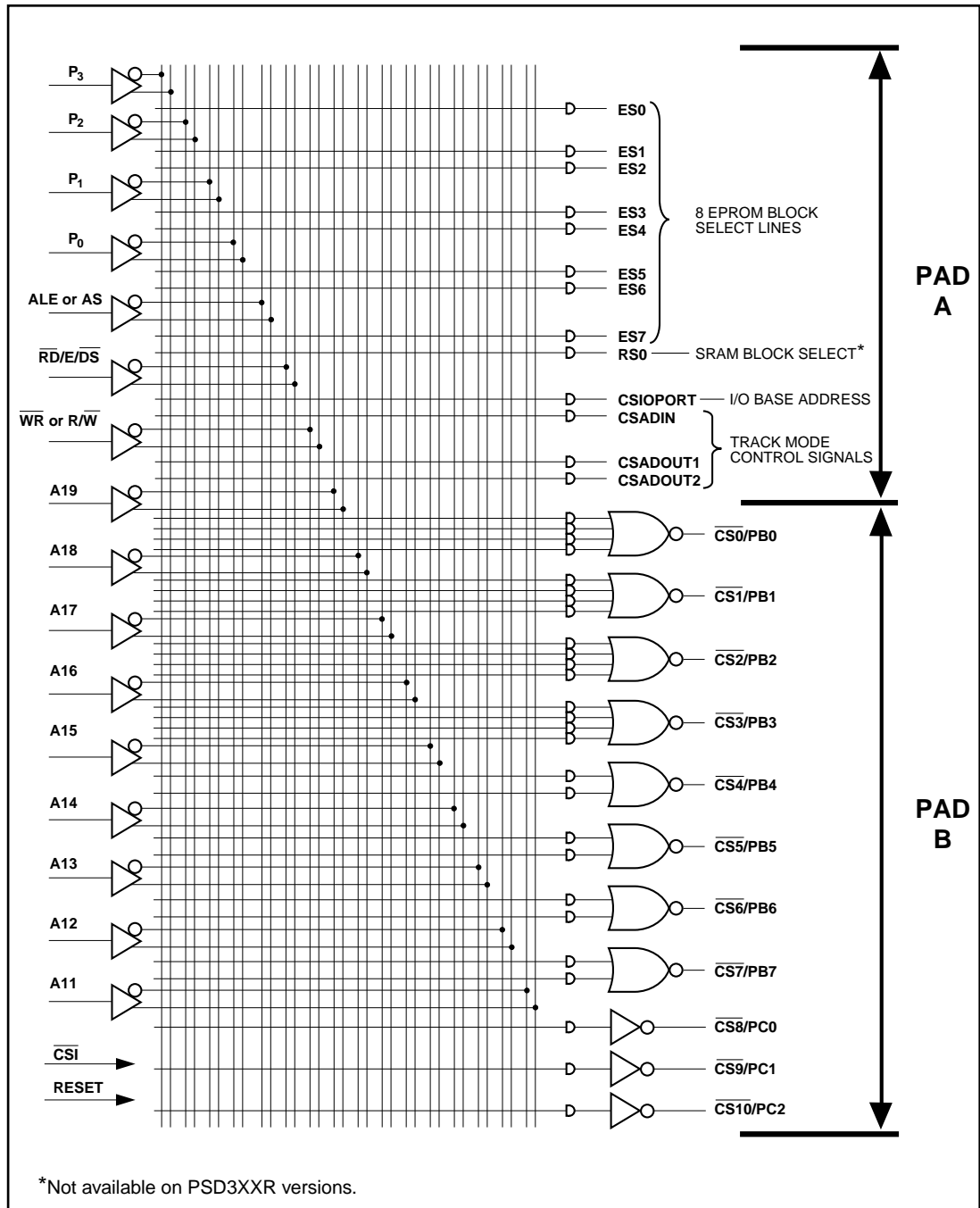
	Multiplexed Address/Data	Non-Multiplexed Address/Data
8-bit Data Bus		
Port A	I/O or low-order address lines or low-order multiplexed address/data byte	D0–D7 data bus byte
Port B	I/O and/or $\overline{CS0}$ – $\overline{CS7}$	I/O and/or $\overline{CS0}$ – $\overline{CS7}$
AD0/A0–AD7/A7	Low-order multiplexed address/data byte	Low-order address bus byte
A8–A15	High-order address bus byte	High-order address bus byte

Programmable Address Decoder (PAD)

The PSD3XX consists of two programmable arrays referred to as PAD A and PAD B (Figure 3). PAD A is used to generate chip select signals derived from the input address to the internal EPROM blocks, SRAM, I/O ports, and Track Mode signals. All its I/O functions are listed in Table 3 and shown in Figure 3. PAD B outputs to Ports B and C for off-chip usage.

PAD B can also be used to extend the decoding to select external devices or as a random logic replacement. The input bus to both PAD A and PAD B is the same. By using the PSDsoft Development Tools software, each programmable bit in the PAD array can have one of three logic states of 0, 1, and don't care (X). In a user's logic design, both PADs can share the same inputs, using the X for input signals that are not supposed to affect other functions. The PADs use reprogrammable CMOS EPROM technology and can be programmed and erased (if using windowed packages) by the user.

Figure 3.
PAD Description



- NOTES:**
4. $\overline{CS1}$ is a power-down signal. When high, the PAD is in stand-by mode and all its outputs become non-active. See Tables 12 and 13.
 5. RESET deselected all PAD output signals. See Tables 10 and 11.
 6. A18, A17, and A16 are internally multiplexed with $\overline{CS10}$, $\overline{CS9}$, and $\overline{CS8}$, respectively. Either A18 or $\overline{CS10}$, A17 or $\overline{CS9}$, and A16 or $\overline{CS8}$ can be routed to the external pins of Port C. Port C can be configured as either input or output.
 7. P₀–P₃ are not included on PSD3X1 devices.
 8. DS is not available on PSD3X1 devices.



Table 3.
PSD3XX PAD A
and PAD B
Functions

Function	
PAD A and PAD B Inputs	
A19/ $\overline{\text{CSi}}$	In $\overline{\text{CSi}}$ mode (when high), PAD deselects all of its outputs and enters a power-down mode (see Tables 12 and 13). In A19 mode, it is another input to the PAD.
A16–A18	These are general purpose inputs from Port C. See Figure 3, Note 6.
A11–A15	These are address inputs.
P0–P3	These are page number inputs (for the PSD302/312/303/313 only).
$\overline{\text{RD/E/DS}}$	This is the read pulse or enable strobe input. (Note 10)
$\overline{\text{WR}}$ or $\overline{\text{R/W}}$	This is the write pulse or $\overline{\text{R/W}}$ select signal.
ALE	This is the ALE input to the chip.
RESET	This deselects all outputs from the PAD; it can not be used in product term equations. See Tables 10 and 11 and Figure 11.
PAD A Outputs	
ES0–ES7	These are internal chip-selects to the 8 EPROM banks. Each bank can be located on any boundary that is a function of one product term of the PAD address inputs.
RS0	This is an internal chip-select to the SRAM. Its base address location is a function of one term of the PAD address inputs. (Not available on PSD3XXR versions).
CSIOPORT	This internal chip-select selects the I/O ports. It can be placed on any boundary that is a function of one product term of the PAD inputs. See Tables 6 and 7.
CSADIN	This internal chip-select, when Port A is configured as a low-order address/data bus in the track mode (CPAF2 = 1), controls the input direction of Port A. CSADIN is gated externally to the PAD by the internal read signal. When CSADIN and a read operation are active, data presented on Port A flows out of AD0/A0–AD7/A7. This chip-select can be placed on any boundary that is a function of one product term of the PAD inputs. See Figure 5.
CSADOUT1	This internal chip-select, when Port A is configured as a low-order address/data bus in track mode (CPAF2 = 1), controls the output direction of Port A. CSADOUT1 is gated externally to the PAD by the ALE signal. When CSADOUT1 and the ALE signal are active, the address presented on AD0/A0–AD7/A7 flows out of Port A. This chip-select can be placed on any boundary that is a function of one product term of the PAD inputs. See Figure 5.
CSADOUT2	This internal chip-select, when Port A is configured as a low-order address/data bus in the track mode (CPAF2 = 1), controls the output direction of Port A. CSADOUT2 must include the write-cycle control signals as part of its product term. When CSADOUT2 is active, the data presented on AD0/A0–AD7/A7 flows out of Port A. This chip-select can be placed on any boundary that is a function of one product term of the PAD inputs. See Figure 5.
PAD B Outputs	
$\overline{\text{CS0}}-\overline{\text{CS3}}$	These chip-select outputs can be routed through Port B. Each of them is a function of up to four product terms of the PAD inputs.
$\overline{\text{CS4}}-\overline{\text{CS7}}$	These chip-select outputs can be routed through Port B. Each of them is a function of up to two product terms of the PAD inputs.
$\overline{\text{CS8}}-\overline{\text{CS10}}$	These chip-select outputs can be routed through Port C. See Figure 3, Note 6. Each of them is a function of one product term of the PAD inputs.



Configuration Bits

The configuration bits shown in Table 4 are non-volatile cells that let the user set the device, I/O, and control functions to the proper operational mode. Table 5 lists all configuration bits. The configuration bits are programmed and verified during the programming phase. In operational mode, they are not accessible. These tables are for information only since to implement to a specific mode, the PSDsoft Development software will automatically set the configuration bits by using simple interactive menus.

Table 4.
PSD3XX
Non-Volatile
Configuration
Bits

<i>Use This Bit</i>	<i>To</i>
CDATA	Set the data bus width to 8 or 16 bits (PSD30X only).
CADDRDAT	Set the address/data buses to multiplexed or non-multiplexed mode.
CEDS	Determine the polarity and functionality of read and write. (Note 10)
CA19/ $\overline{\text{CSI}}$	Set A19/ $\overline{\text{CSI}}$ to $\overline{\text{CSI}}$ (power-down) or A19 input.
CALE	Set the ALE polarity.
CPAF2	Set Port A either to track the low-order byte of the address/data multiplexed bus or to select the I/O or address option.
CSECURITY	Set the security on or off (a secured part can not be duplicated).
CRESET	Set the RESET polarity.
$\overline{\text{COMB}}/\text{SEP}$	Set PSEN and $\overline{\text{RD}}$ for combined or separate address spaces (see Figures 9 and 10).
CPAF1 (8 Bits)	Configure each pin of Port A in multiplexed mode to be an I/O or address out.
CPACOD (8 Bits)	Configure each pin of Port A as an open drain or active CMOS pull-up output.
CPBF (8 Bits)	Configure each pin of Port B as an I/O or a chip-select output.
CPBCOD (8 Bits)	Configure each pin of Port B as an open drain or active CMOS pull-up output.
CPCF (3 Bits)	Configure each pin of Port C as an address input or a chip-select output.
CADDHLT	Configure pins A16 – A19 to go through a latch or to have their latch transparent.
CADLOG (4 Bits)	Configure A16 – A19 individually as logic or address inputs. (Note 10)
CATD	Configure pins A16–A19 as PAD logic inputs or high-order address inputs (Note 9).
CLOT	Determine in non-multiplexed mode if address inputs are transparent or latched (Note 10).
CRRWR	Set the $\overline{\text{RD}}/\text{E}$ and $\overline{\text{WR}}/\text{V}_{\text{PP}}$ or $\text{R}/\overline{\text{W}}$ pins to $\overline{\text{RD}}$ and $\overline{\text{WR}}$ pulse, or to E strobe and $\text{R}/\overline{\text{W}}$ status (Note 9).
CRRWR	Configure the polarity and control methods of read and write cycles. (Note 10)
CMISER	Controls the lower-power mode.

NOTES: 9. PSD3X1 only.

10. PSD302/312/303/313/304R/314R only.

This data sheet provides a complete listing of the function of each configuration bit in all control registers. In general, you will not need to be concerned about the details of most of these bits. The development software will set the bits automatically using information from your design files.



Table 5.
PSD3XX
Configuration
Bits^{11,12}

Configuration Bits	No. of Bits	Function
CDATA (Note 13)	1	8-bit or 16-bit Data Bus Width CDATA = 0 eight bits CDATA = 1 sixteen bits
CADDRDAT	1	ADDRESS/DATA Multiplexed (separate buses) CADDRDAT = 0, non-multiplexed CADDRDAT = 1, multiplexed
CA19/ $\overline{\text{CSI}}$	1	A19 or $\overline{\text{CSI}}$ CA19/ $\overline{\text{CSI}}$ = 0, enable power-down CA19/ $\overline{\text{CSI}}$ = 1, enable A19 input to PAD
CALE	1	Active HIGH or Active LOW CALE = 0, Active high CALE = 1, Active low
CRESET	1	Active high or active low CRESET = 0, active low reset signal CRESET = 1, active high reset signal
$\overline{\text{COMB/SEP}}$	1	Combined or Separate Address Space for SRAM and EPROM 0 = Combined, 1 = Separate
CPAF1	8	Port A I/Os or A0–A7 CPAF1 = 0, Port A pin = I/O CPAF1 = 1, Port A pin = A0 – A7
CPAF2	1	Port A AD0–AD7 (address/data multiplexed bus) CPAF2 = 0, address or I/O on Port A (according to CPAF1) CPAF2 = 1, address/data multiplexed on Port A (track mode)
CATD (Note 15)	1	A16–A19 address or logic inputs CATD = 0, logic inputs CATD = 1, address inputs
CADDHLT	1	A16–A19 Transparent or Latched CADDHLT = 0, Address latch transparent CADDHLT = 1, Address latched (ALE dependent)
CSECURITY	1	SECURITY On/Off CSECURITY = 0, off CSECURITY = 1, on
CLOT (Note 14)	1	A0–A15 Address Inputs are transparent or ALE-dependent in non-multiplexed modes CLOT = 0, transparent CLOT = 1, ALE-dependent
CRRWR CEDS (Note 14)	2	Determine the polarity and control methods of read and write cycles. CEDS CRRWR 0 0 $\overline{\text{RD}}$ and $\overline{\text{WR}}$ active low pulses 0 1 R/ $\overline{\text{W}}$ status and high E pulse 1 1 R/ $\overline{\text{W}}$ status and low $\overline{\text{DS}}$ pulse
CRRWR (Note 15)	1	CRRWR = 0, $\overline{\text{RD}}$ and $\overline{\text{WR}}$ active low strobes CRRWR = 1, R/ $\overline{\text{W}}$ status and E active high pulse
CPACOD	8	Port A CMOS or Open Drain Output CPACOD = 0, CMOS output CPACOD = 1, open-drain output

**Table 5.
PSD3XX
Configuration
Bits (Cont.)**

Configuration Bits	No. of Bits	Function
CPBF	8	Port B is I/O or $\overline{CS0}$ – $\overline{CS7}$ CPBF = 0, Port B pin is $\overline{CS0}$ – $\overline{CS7}$ CPBF = 1, Port B pin is I/O
CPBCOD	8	Port B CMOS or Open Drain CPBCOD = 0, CMOS output CPBCOD = 1, open-drain output
CPCF	3	Port C A16–A18 or $\overline{CS8}$ – $\overline{CS10}$ CPCF = 0, Port C pin is A16–A18 CPCF = 1, Port C pin is $\overline{CS8}$ – $\overline{CS10}$
CADLOG (Note 14)	4	Port C: A16–A19 Address or Logic Input CADLOG = 0, Port C pin or A19/ $\overline{CS1}$ is logic input CADLOG = 1, Port C pin or A19/ $\overline{CS1}$ is address input
CMISER	1	Default: CMISER = 0 CMISER = 1, lower-power mode

- NOTES:** 11. The PSD Development software will guide the user to the proper configuration choice.
12. In an unprogrammed or erased part, all configuration bits are 0.
13. PSD30X only.
14. PSD3X2/3X3 only.
15. PSD3X1 only.

Port Functions

The PSD3XX has three I/O ports (Ports A, B, and C) that are configurable at the bit level. This permits great flexibility and a high degree of customization for specific applications. The following is a description of each port. Figure 4 shows the pin structure of Port A.

Port A in Multiplexed Address/Data Mode

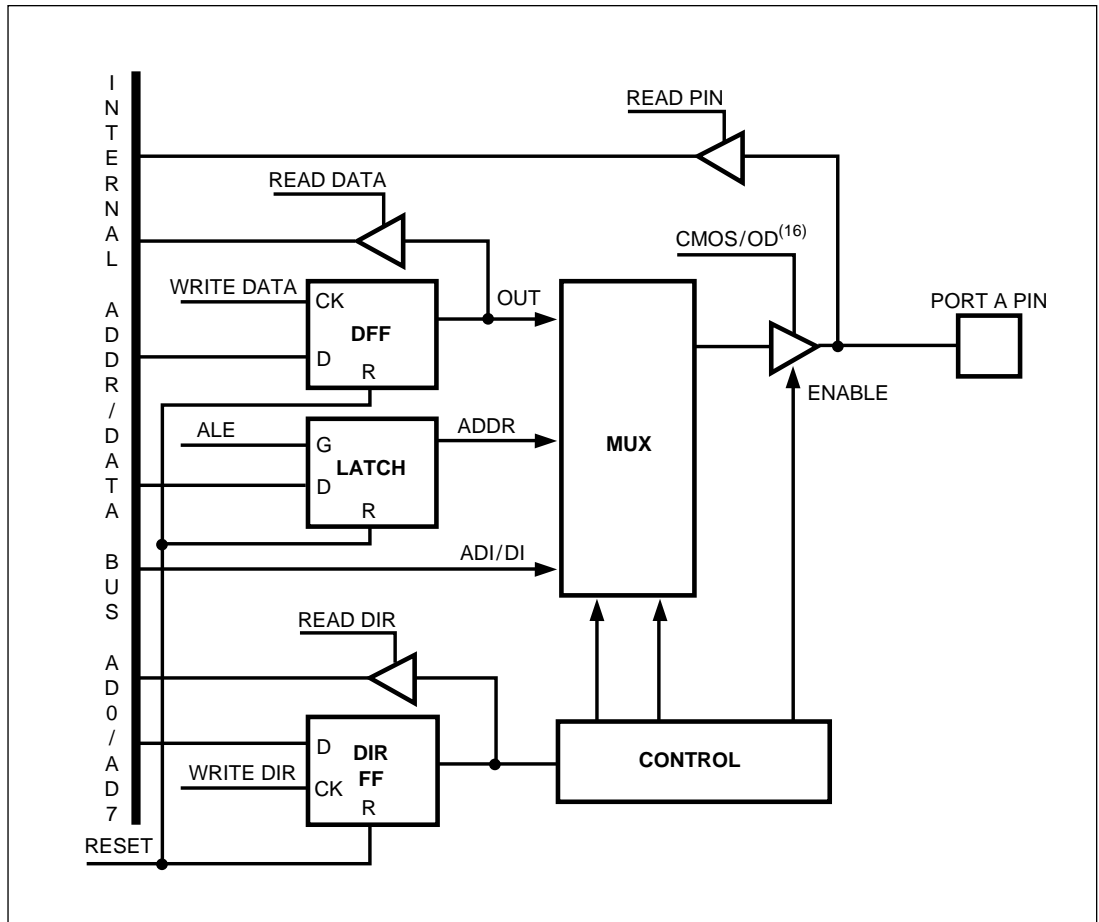
The default configuration of Port A is I/O. In this mode, every pin can be set as an input or output by writing into the respective pin's direction flip flop (DIR FF, in Figure 4). As an output, the pin level can be controlled by writing into the respective pin's data flip flop (DFF, in Figure 4). When DIR FF = 1, the pin is configured as an output. When DIR FF = 0, the pin is configured as an input. The controller can read the DIR FF bits by accessing the READ DIR register; it can read the DFF bits by accessing the READ DATA register. Port A pin levels can be read by accessing the READ PIN register. Individual pins can be configured as CMOS or open drain outputs. Open drain pins require external pull-up resistors. For addressing information, refer to Tables 6 and 7.

Alternatively, each bit of Port A can be configured as a low-order latched address bus bit. The address is provided by the port address latch, which latches the address on the trailing edge of ALE. PA0–PA7 can become A0–A7, respectively. This feature enables the user generate low-order address bits to access external peripherals or memory that require several low-order address lines.

Another mode of Port A, i.e., Track Mode (CPAF2 = 1) sets the entire port to track the inputs AD0/A0–AD7/A7, depending on specific address ranges defined by the PAD's CSADIN, CSADOUT1, and CSADOUT2 signals. This feature lets the user interface the microcontroller to shared external resources without requiring external buffers and decoders. In this mode, the port is effectively a bi-directional buffer. The direction is controlled by using the input signals ALE, RD/E or RD/E/DS, WR/V_{PP} or R/W, and the internal PAD outputs CSADOUT1, CSADOUT2 and CSADIN (see Figure 5). When CSADOUT1 and ALE are true, the address on the input AD0/A0–AD7/A7 pins is output through Port A. (Carefully check the generation of CSADOUT1, and ensure that it is stable during the ALE pulse. When CSADOUT2 is active, a write operation is performed (see note to Figure 5). The data on the input AD0/A0–AD7/A7 pins flows out through Port A. When CSADIN and a read operation is performed (depending on the mode of the RD/E or RD/E/DS, and WR/V_{PP} or R/W pins), the data on Port A flows out through the AD0/A0–AD7/A7 pins. In this operational mode, Port A is tri-stated when none of the above-mentioned three conditions exist.

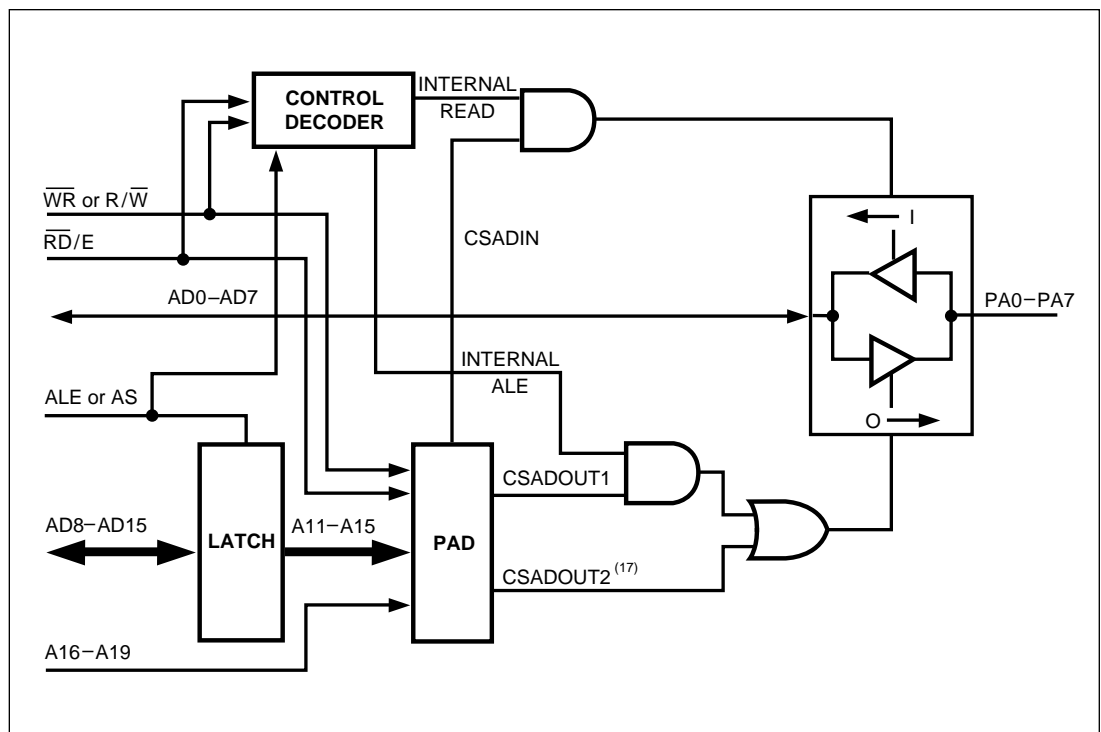


Figure 4.
Port A Pin
Structure



NOTE: 16. CMOS/OD determines whether the output is open drain or CMOS.

Figure 5.
Port A Track
Mode



NOTE: 17. The expression for CSADOUT2 must include the following write operation cycle signals:
For CRRWR = 0, CSADOUT2 must include $\overline{WR} = 0$.
For CRRWR = 1, CSADOUT2 must include $E = 1$ and $R/\overline{W} = 0$.

Port Functions (Cont.)

Port A in Non-Multiplexed Address/Data Mode

In this mode, Port A becomes the low order data bus byte of the chip. When reading an internal location, data is presented on Port A pins. When writing to an internal location, data present on Port A pins is written to that location.

Port B in Multiplexed Address/Data and in 8-Bit Non-Multiplexed Modes

The default configuration of Port B is I/O. In this mode, every pin can be set as an input or output by writing into the respective pin's direction flip flop (DIR FF, in Figure 6). As an output, the pin level can be controlled by writing into the respective pin's data flip flop (DFF, in Figure 6). When DIR FF = 1, the pin is configured as an output. When DIR FF = 0, the pin is configured as an input. The controller can read the DIR FF bits by accessing the READ DIR register; it can read the DFF bits by accessing the READ DATA register. Port B pin levels can be read by accessing the READ PIN register. Individual pins can be configured as CMOS or open drain outputs. Open drain pins require external pull-up resistors. For addressing information, refer to Tables 6 and 7.

Alternately, each bit of Port B can be configured to provide a chip-select output signal from PAD B. PB0–PB7 can provide $\overline{CS0}$ – $\overline{CS7}$, respectively. Each of the signals $\overline{CS0}$ – $\overline{CS3}$ is comprised of four product terms. Thus, up to four ANDed expressions can be ORed while deriving any of these signals. Each of the signals $\overline{CS4}$ – $\overline{CS7}$ is comprised of two product terms. Thus, up to two ANDed expressions can be ORed while deriving any of these signals.

Port B in 16-Bit Non-Multiplexed Address/Data Mode (PSD30X)

In this mode, Port B becomes the high-order data bus byte of the chip. When reading an internal high-order data bus byte location, the data is presented on Port B pins. When writing to an internal high-order data bus byte location, data present on Port B is written to that location. See Table 9.

Accessing the I/O Port Registers

Tables 6 and 7 show the offset values with the respect to the base address defined by the CSIOPORT. They let the user access the corresponding registers.

Port C in All Modes

Each pin of Port C (shown in Figure 7) can be configured as an input to PAD A and PAD B or output from PAD B. As inputs, the pins are named A16–A18. Although the pins are given names of the high-order address bus, they can be used for any other address lines or logic inputs to PAD A and PAD B. For example, A8–A10 can also be connected to those pins, improving the boundaries of $\overline{CS0}$ – $\overline{CS7}$ resolution to 256 bytes. As inputs, they can be individually configured to be logic or address inputs. A logic input uses the PAD only for Boolean equations that are implemented in any or all of the $\overline{CS0}$ – $\overline{CS10}$ PAD B outputs. Port C addresses can be programmed to latch the inputs by the trailing edge ALE or to be transparent.

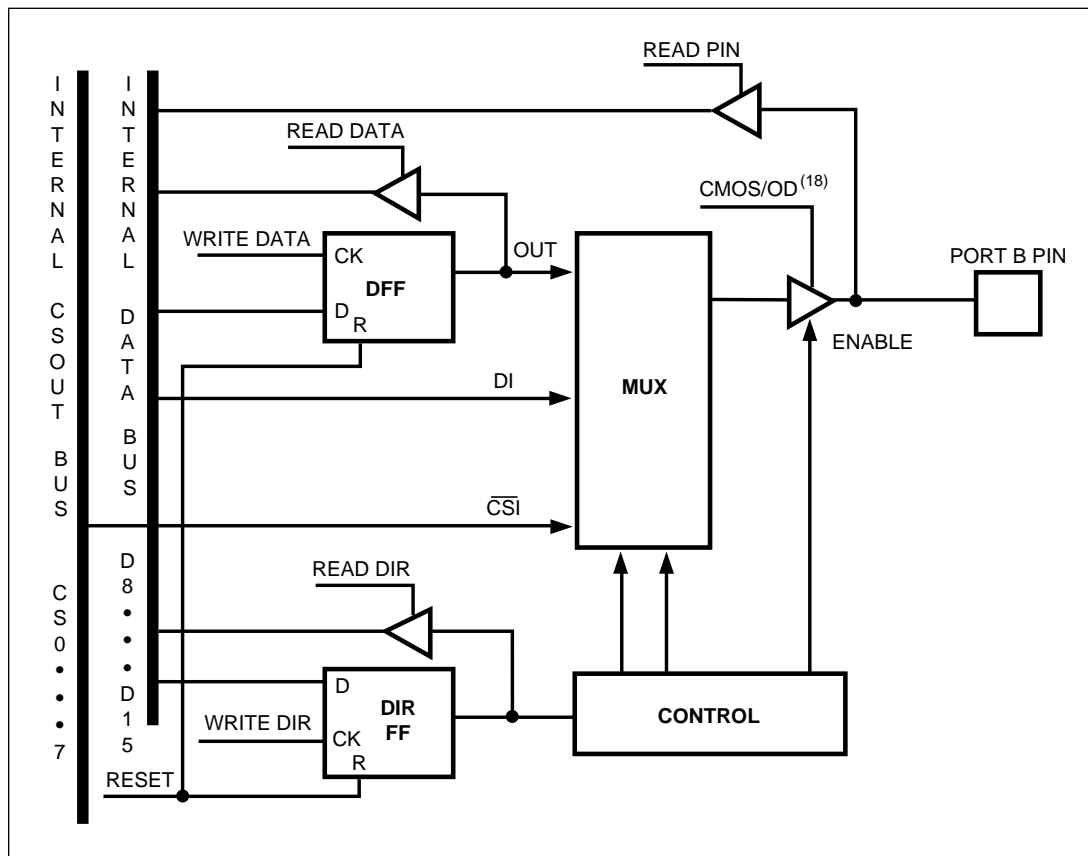
Alternately, PC0–PC2 can become $\overline{CS8}$ – $\overline{CS10}$ outputs, respectively, providing the user with more external chip-select PAD outputs. Each of the signals $\overline{CS8}$ – $\overline{CS10}$ is comprised of one product term.

ALE/AS and A0–A15 in Non-Multiplexed Modes (PSD3X2/3X3)

In non-multiplexed modes, A0–A15 are address inputs only and can become transparent (CLOT = 0) or ALE dependent (CLOT = 1). In transparent mode, the ALE/AS pin can be used as an additional logic input to the PADs. The non-multiplexed ALE dependent mode is useful in applications for which the host processor has a multiplex address/data bus and AD0/A0–AD7/A7 are not multiplexed with A0–A7 but rather are multiplexed with other address lines. In these applications, Port A serves as a data bus and each of its pins can be directly connected to the corresponding host's multiplexed pin, where that data bit is expected. (See Table 8.)



Figure 6.
Port B Pin
Structure



NOTE: 18. CMOS/OD determines whether the output is open drain or CMOS.

Table 6.
I/O Port
Addresses in an
8-bit Data Bus
Mode

<i>Register Name</i>	<i>Byte Size Access of the I/O Port Registers Offset from the CSIOPORT</i>
Pin Register of Port A	+ 2 (accessible during read operation only)
Direction Register of Port A	+ 4
Data Register of Port A	+ 6
Pin Register of Port B	+ 3 (accessible during read operation only)
Direction Register of Port B	+ 5
Data Register of Port B	+ 7
Page Register	+18

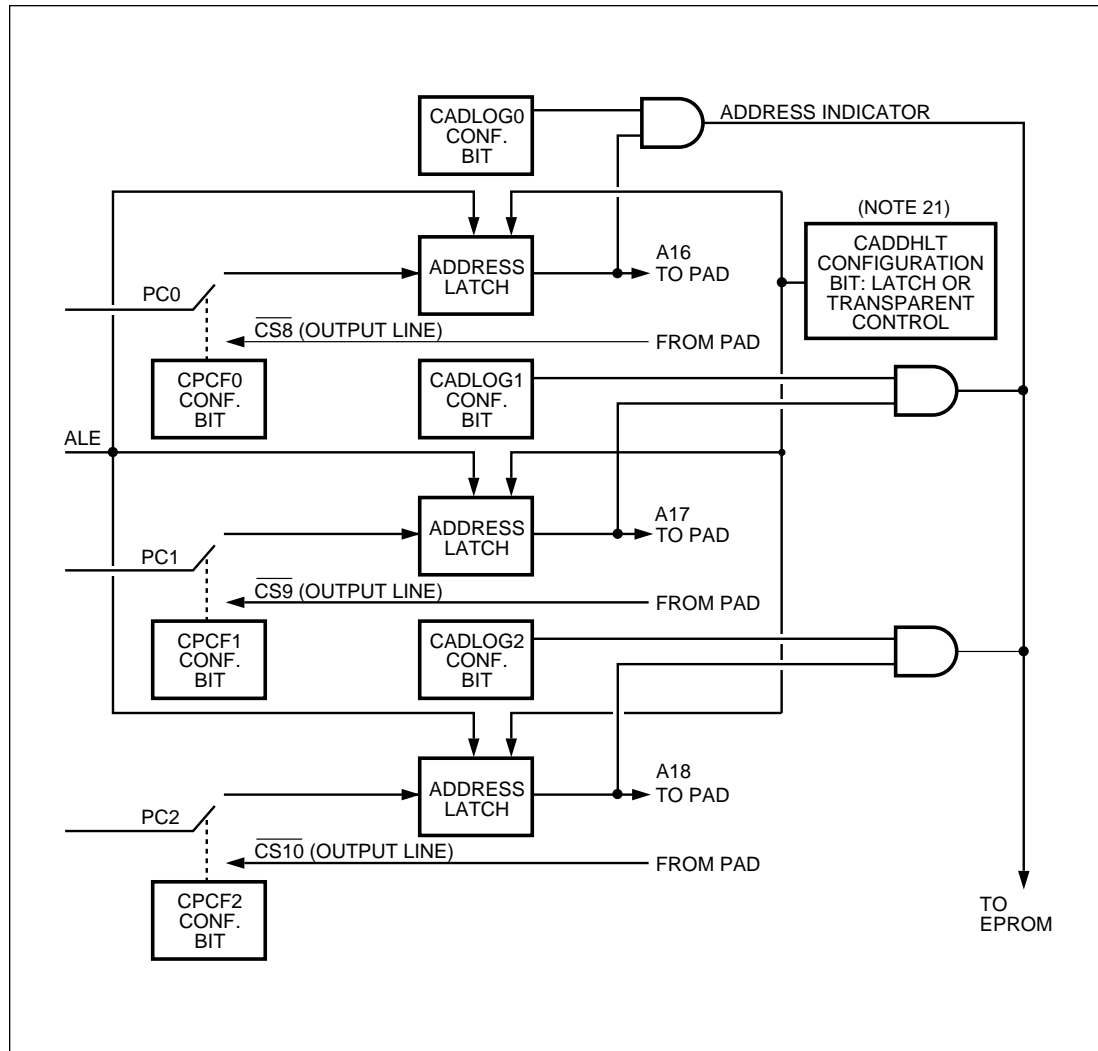
Table 7.
I/O Port
Addresses in a
16-bit Data Bus
Mode^{19,20}
(PSD30X)

<i>Register Name</i>	<i>Word Size Access of the I/O Port Registers Offset from the CSIOPORT</i>
Pin Register of Ports B and A	+ 2 (accessible during read operation only)
Direction Register of Ports B and A	+ 4
Data Register of Ports B and A	+ 6

NOTES: 19. When the data bus width is 16, Port B registers can only be accessed if the $\overline{\text{BHE}}$ signal is low.

20. I/O Ports A and B are still byte-addressable, as shown in Table 6. For I/O Port B register access, BHE must be low.

Figure 7.
Port C Structure



- NOTES:** 21. The CADDHLT configuration bit determines if A18–A16 are transparent via the latch, or if they must be latched by the trailing edge of the ALE strobe.
 22. PSD3X2/3X3/3X4R: Individual pins can be configured independently as address or logic inputs (CADLOG, bits 0–2).
 PSD3X1: All Port C pins are either address or logic inputs (CATD).

A16–A19 Inputs

If one or more of the pins PC0, PC1, PC2 and $\overline{\text{CS}}/\text{A19}$ are configured as inputs, the configuration bits CADDHLT and CATD define their functionality inside the part. CADDHLT determines if these inputs are to be latched by the trailing edge of the ALE or AS signal (CADDHLT = 1), or enabled into the PSD3XX at all times (CADDHLT = 0, transparent mode). CATD determines whether these lines are high-order address lines, that take part in the derivation of EPROM select signals inside the chip (CATD = 1), or logic input lines that have no impact on memory or I/O selections (CATD = 0). Logic input lines typically participate in the Boolean expressions implemented in the PAD B. Unused input pins should be tied to V_{CC} or GND.

EPROM

The EPROM has 8 banks of memory. Each bank can be placed in any address location by programming the PAD. Bank0–Bank7 is selected by PAD outputs ES0–ES7, respectively.

Device	EPROM Size	EPROM Architecture		EPROM Bank Architecture (8 ea)	
		x8	x16	x8	x16
PSD301	256Kb	32K x 8	16K x 16	4K x 8	2K x 16
PSD311	256Kb	32K x 8	–	4K x 8	–
PSD302	512Kb	64K x 8	32K x 16	8K x 8	4K x 16
PSD312	512Kb	64K x 8	–	8K x 8	–
PSD303	1Mb	128K x 8	64K x 16	16K x 8	8K x 16
PSD313	1Mb	128K x 8	–	16K x 8	–
PSD304R	2Mb	256K x 8	128K x 16	32K x 8	16K x 8
PSD314R	2Mb	256K x 8	–	32K x 8	–

SRAM

Each PSD3XX device has 16K bits of SRAM (except the PSD3XXR versions which have no SRAM). Depending on the configuration of the data bus, the SRAM organization can be 2K x 8 (8-bit data bus) or 1K x 16 (16-bit data bus). The SRAM is selected by the RS0 output of the PAD.

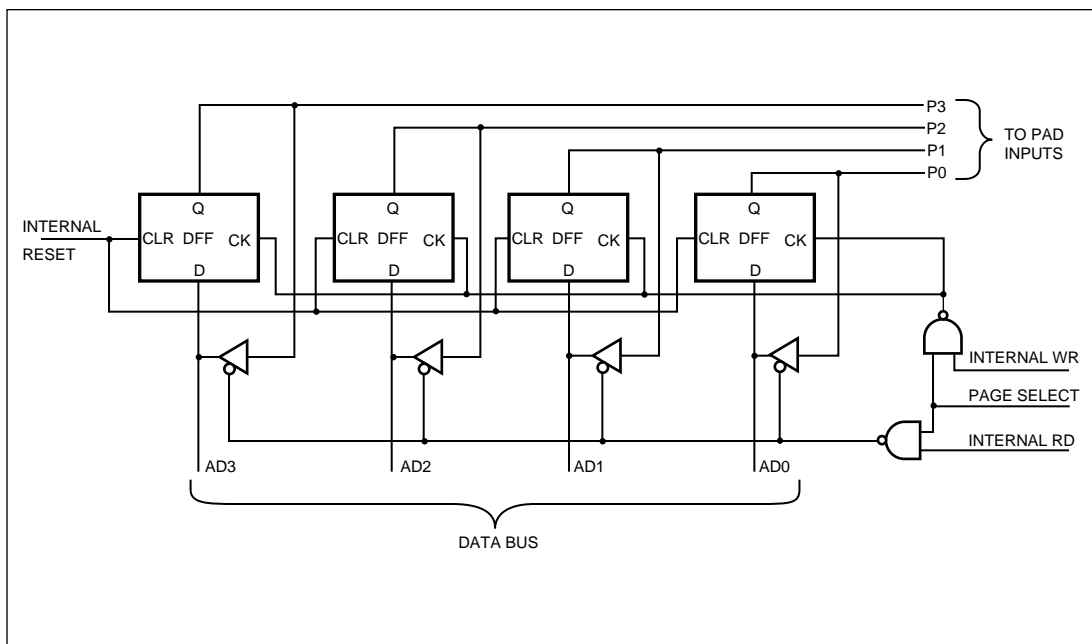
Table 8.
Signal Latch
Status in All
Operating Modes

Signal Name	Configuration Bits	Configuration Mode	Signal Latch Status
AD8/A8– AD15/A15	CDATA , CADDRDAT, CLOT = 0	8-bit data, non-multiplexed	Transparent
	CDATA, CADDRDAT = 0, CLOT = 1		ALE Dependent
	CDATA = 1, CADDRDAT, CLOT = 0	16-bit data, non-multiplexed	Transparent
	CDATA = 1, CADDRDAT = 0, CLOT = 1		ALE Dependent
	CDATA = 0, CADDRDAT = 1	8-bit data, multiplexed	Transparent
	CDATA = 1, CADDRDAT = 1	16-bit data, multiplexed	ALE Dependent
AD0/A0– AD7/A7	CADDRDAT = 0, CLOT = 0	non-multiplexed modes	Transparent
	CADDRDAT = 0, CLOT = 1		ALE Dependent
	CADDRDAT = 1	multiplexed modes	ALE Dependent
$\overline{\text{BHE}}$ / $\overline{\text{PSEN}}$	CDATA = 0	8-bit data, $\overline{\text{PSEN}}$ is active	Transparent
	CDATA = 1, CADDRDAT = 0	16-bit data, non-multiplexed mode, $\overline{\text{BHE}}$ is active	Transparent
A19 and PC2–PC0	CDATA = 1, CADDRDAT = 1	16-bit data, multiplexed mode, $\overline{\text{BHE}}$ is active	ALE Dependent
	CADDHLT = 0	A16–A19 can become logic inputs	Transparent
	CADDHLT = 1	A16–A19 can become multiplexed address lines	ALE Dependent

Memory Paging (PSD3X2/3X3/ 3X4R)

The page register consists of four flip-flops, which can be read from, or written to, through the I/O address space (CSIOPORT). The page register is connected to the D3–D0 lines. The Page Register address is CSIOPORT + 18H. The page register outputs are P3–P0, which are fed into the PAD. This enables the host microcontroller to enlarge its address space by a factor of 16 (there can be a maximum of 16 pages). See Figure 8.

Figure 8.
Page Register
(PSD3X2/3X3/
3X4R)



Control Signals

The PSD3XX control signals are \overline{WR}/V_{PP} or R/\overline{W} , \overline{RD}/E or $\overline{RD}/E/\overline{DS}$, ALE or AS, $\overline{BHE}/\overline{PSEN}$ or \overline{PSEN} , \overline{RESET} , and A19/ \overline{CSI} . Each of these signals can be configured to meet the output control signal requirements of various microcontrollers.

\overline{WR}/V_{PP} or R/\overline{W}

In operational mode, this signal can be configured as \overline{WR} or R/\overline{W} . As \overline{WR} , all write operations are activated by an active low signal on this pin. As R/\overline{W} , the pin operates with the E strobe of the $\overline{RD}/E/\overline{DS}$ or \overline{RD}/E pin. When R/\overline{W} is high, an active high signal on the $\overline{RD}/E/\overline{DS}$ or \overline{RD}/E pin performs a read operation. When R/\overline{W} is low, an active high signal on the $\overline{RD}/E/\overline{DS}$ or \overline{RD}/E pin performs a write operation.

$\overline{RD}/E/\overline{DS}$ (or \overline{RD}/E on PSD3X1)

In operational mode, this signal can be configured as \overline{RD} , E, or \overline{DS} . As \overline{RD} , all read operations are activated by an active low signal on this pin. As E, the pin operates with the R/\overline{W} signal of the \overline{WR}/V_{PP} or R/\overline{W} pin. When R/\overline{W} is high, an active high signal on the $\overline{RD}/E/\overline{DS}$ pin performs a read operation. When R/\overline{W} is low, an active high signal on the $\overline{RD}/E/\overline{DS}$ pin performs a write operation.

As \overline{DS} , the pin functions with the R/\overline{W} signal as an active low data strobe signal. As \overline{DS} , the R/\overline{W} defines the mode of operation (Read or Write).

ALE or AS

ALE polarity is programmable. When programmed to be active high, a high on the pin causes the input address latches, Port A address latches, Port C, and A19 address latches to be transparent. The falling edge of ALE locks the information into the latches. When ALE is programmed to be active low, a low on the pin causes the input address latches, Port A address latches, Port C, and A19 address latches to be transparent. The rising edge of ALE locks the appropriate information into the latches.

$\overline{BHE}/\overline{PSEN}$

This pin's function depends on the PSD3XX data bus width. If it is 8 bits, the pin is \overline{PSEN} ; if it is 16 bits, the pin is \overline{BHE} . In 8-bit mode, the \overline{PSEN} function enables the user to work with two address spaces: program memory and data memory (if COMB/SEP = 1). In this mode, an active low signal on the \overline{PSEN} pin causes the EPROM to be read if selected. The SRAM and I/O ports read operation are done by \overline{RD} low (CRRWR = 0), or by E high and R/\overline{W} high (CRRWR = 1, CEDS = 0) or by \overline{DS} low and R/\overline{W} high (CRRWR, CEDS = 1).

Whenever a member of the 8031 family (or any other similar microcontroller) is used, the \overline{PSEN} pin must be connected to the PSEN pin of the microcontroller.

If COMB/SEP = 0, the address spaces of the program and the data are combined. In this configuration (except for the 8031-type case mentioned above), the \overline{PSEN} pin must be tied high to V_{CC} , and the EPROM, SRAM, and I/O ports are read by \overline{RD} low (CRRWR = 0), or by E high and R/\overline{W} high (CRRWR = 1, CEDS = 0) or by \overline{DS} low and R/\overline{W} high (CRRWR, CEDS = 1). See Figures 9 and 10.

In \overline{BHE} mode, this pin enables accessing of the upper-half byte of the data bus. A low on this pin enables a write or read operation to be performed on the upper half of the data bus (see Table 9).

Figure 9.
Combined
Address Space

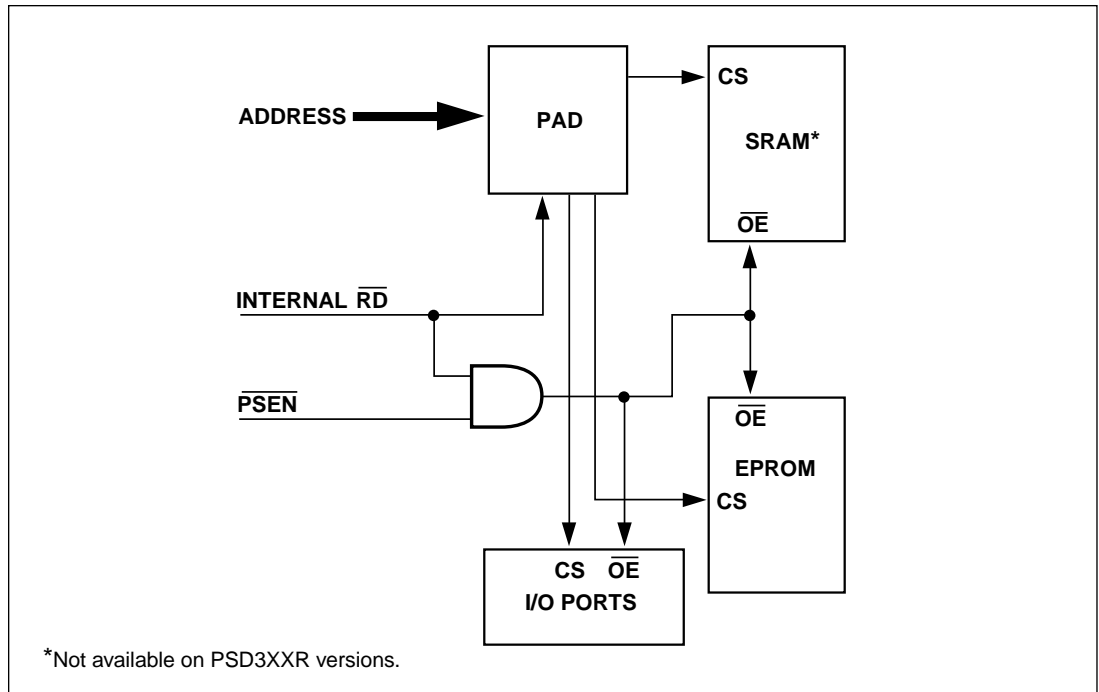


Figure 10.
8031-Type
Separate Code
and Data
Address Spaces

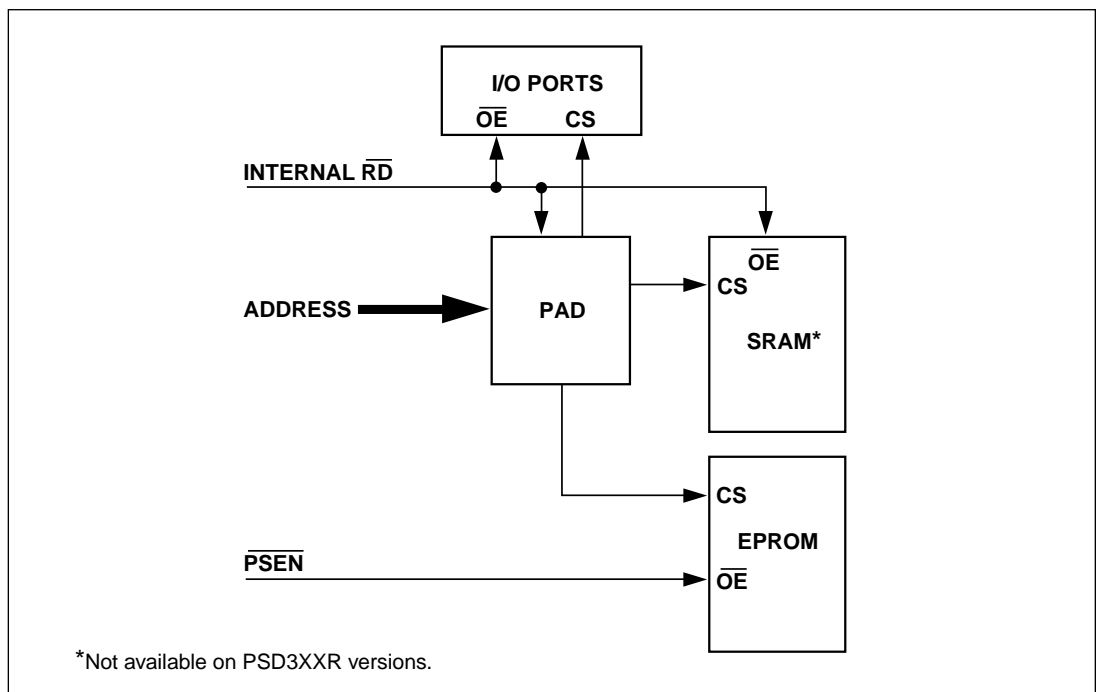


Table 9.
High/Low Byte
Selection Truth
Table (in 16-Bit
Configuration
Only)

\overline{BHE}	A_0	Operation
0	0	Whole Word
0	1	Upper Byte From/To Odd Address
1	0	Lower Byte From/To Even Address
1	1	None

Control Signals (Cont.)

RESET

This is an asynchronous input pin that clears and initializes the PSD3XX. Reset polarity is programmable (active low or active high). Whenever the PSD3XX reset input is driven active for at least 100 ns, the chip is reset. The PSD3XX must be reset at power up before it can be used. Tables 10 and 11 indicate the state of the part during and after reset.

For the PSD3XXL, reset is an asynchronous low signal only. Whenever the reset input is driven low for at least 500 ns, the chip is reset. After reset becomes high, the chip will be operational only after an additional 500 ns. See Figure 11. Note that during boot-up, the part is not automatically reset internally and does require an external reset. Tables 10 and 11 indicate the state of the part during and after reset.

A19/ $\overline{\text{CSI}}$

When configured as $\overline{\text{CSI}}$, a high on this pin deselects, and powers down, the chip. A low on this pin puts the chip in normal operational mode. For PSD3XX states during the power-down mode, see Tables 12 and 13, and Figure 12.

In A19 mode, the pin is an additional input to the PAD. It can be used as an address line (CADLOG3 = 1) or as a general-purpose logic input (CADLOG3 = 0). A19 can be configured as ALE dependent or as transparent input (see Table 8). In this mode, the chip is always enabled.

Table 10.
Signal States
During Reset
Active
(RESET)

Signal	Configuration Mode	Condition
AD0/A0–AD7/A7	All	Input
A8–A15	All	Input
PA0–PA7) (Port A)	I/O Tracking AD0/A0–AD7 Address outputs A0–A7	Input Input Low
PB0–PB7 (Port B)	I/O $\overline{\text{CS}}7$ – $\overline{\text{CS}}0$ CMOS outputs $\overline{\text{CS}}7$ – $\overline{\text{CS}}0$ open drain outputs	Input High Tri-stated
PC0–PC2 (Port C)	Address inputs A16–A18 $\overline{\text{CS}}8$ – $\overline{\text{CS}}10$ CMOS outputs	Input High

Table 11.
Internal States
During and After
Reset Cycle

Component	Signals	Contents
PAD	$\overline{\text{CS}}0$ – $\overline{\text{CS}}10$	All = 1 (Note 23)
	CSADIN, CSADOUT1, CSADOUT2, CSIOPORT, RS0, ES0 – ES7	All = 0 (Note 23)
Data register A	n/a	0
Direction register A	n/a	0
Data register B	n/a	0
Direction register B	n/a	0

NOTE: 23. All PAD outputs are in a non-active state.



Figure 11.
The Reset
Cycle ($\overline{\text{RESET}}$)
(PSD3XXL Only)

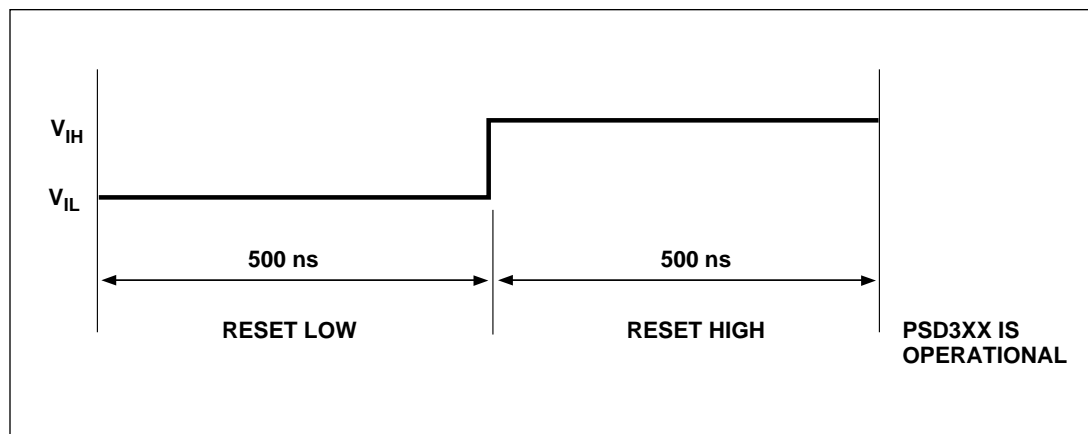


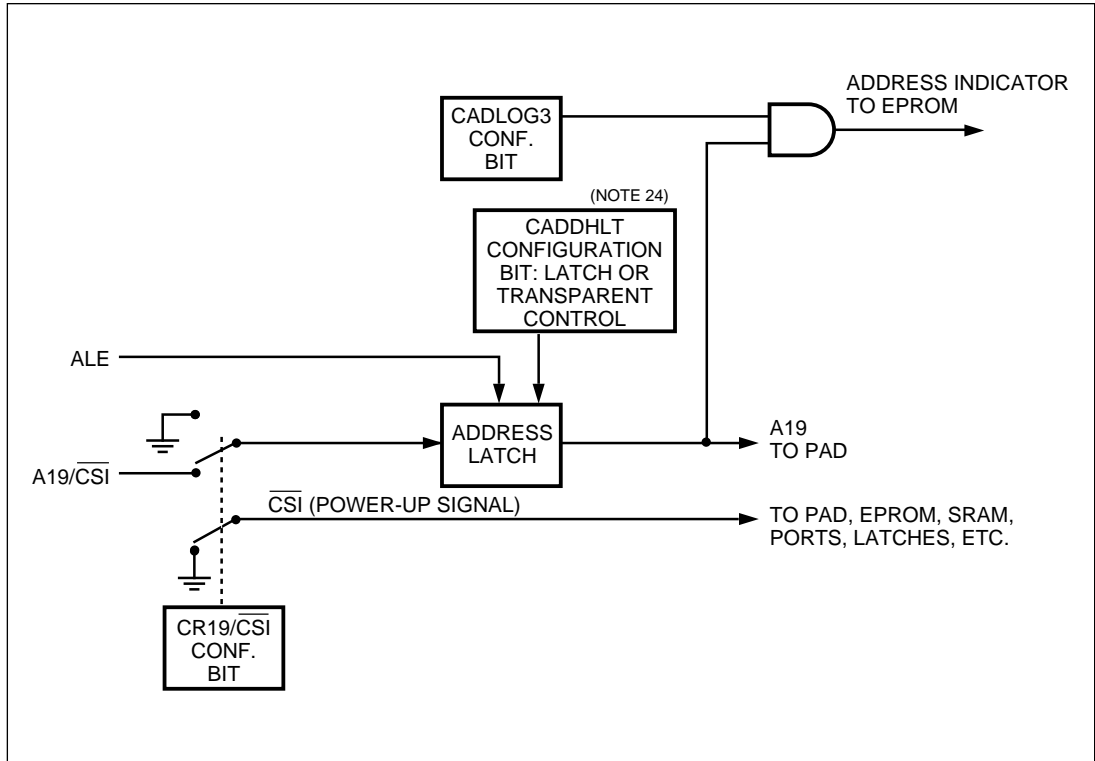
Table 12a.
Signal States
During
Power-Down
Mode
(PSD30X)

<i>Signal</i>	<i>Configuration Mode</i>	<i>Condition</i>
AD0/A0–AD15/A15	All	Input
PA0–PA7	I/O Tracking AD0/A0–AD7/A7 Address outputs A0–A7	Unchanged Input All 1's
PB0–PB7	I/O $\overline{\text{CS}}0$ – $\overline{\text{CS}}7$ CMOS outputs $\overline{\text{CS}}0$ – $\overline{\text{CS}}7$ open drain outputs	Unchanged All 1's Tri-stated
PC0–PC2	Address inputs A18–A16 $\overline{\text{CS}}8$ – $\overline{\text{CS}}10$ CMOS outputs	Input All 1's

Table 12b.
Signal States
During
Power-Down
Mode
(PSD31X)

<i>Signal</i>	<i>Configuration Mode</i>	<i>Condition</i>
AD0/A0–AD7/A7	All	Input
A8–A15	All	Input
PA0–PA7	I/O Tracking AD0/A0–AD7/A7 Address outputs A0–A7	Unchanged Input All 1's
PB0–PB7	I/O $\overline{\text{CS}}0$ – $\overline{\text{CS}}7$ CMOS outputs $\overline{\text{CS}}0$ – $\overline{\text{CS}}7$ open drain outputs	Unchanged All 1's Tri-stated
PC0–PC2	Address inputs A18–A16 $\overline{\text{CS}}8$ – $\overline{\text{CS}}10$ CMOS outputs	Input All 1's

Figure 12.
A19/CSI Cell
Structure



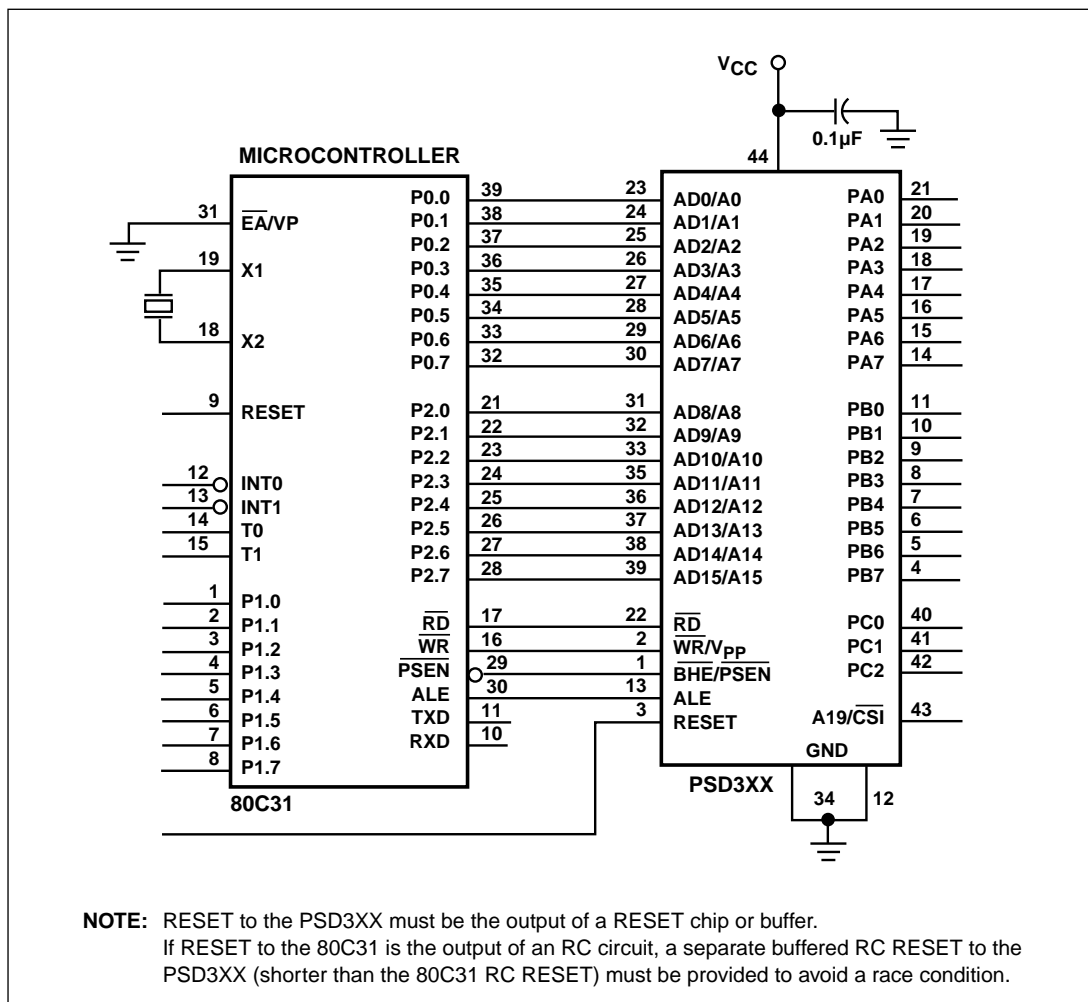
- NOTES:** 24. The CADDHLT configuration bit determines if A19–A16 are transparent via the latch, or if they must be latched by the trailing edge of the ALE strobe.
 25. In the PSD3X1, the CATD configuration bit performs this function for all the A16–A19 lines.

Table 13.
Internal States
During
Power-Down

<i>Component</i>	<i>Signals</i>	<i>Contents</i>
PAD	$\overline{CS0} - \overline{CS10}$	All 1's (deselected)
	CSADIN, CSADOUT1, CSADOUT2, CSIOPORT, RS0, ES0–ES7	All 0's (deselected)
Data register A Direction register A Data register B Direction register B	n/a n/a n/a n/a	All unchanged



Figure 13.
PSD3XX
Interface With
Intel's 80C31



The configuration bits for Figure 13 are:

CALE	0	COMB/SEP	0 or 1 (both valid)
CDATA	0	CRRWR	0
CADDRDAT	1	CEDS	0
CRESET	1		

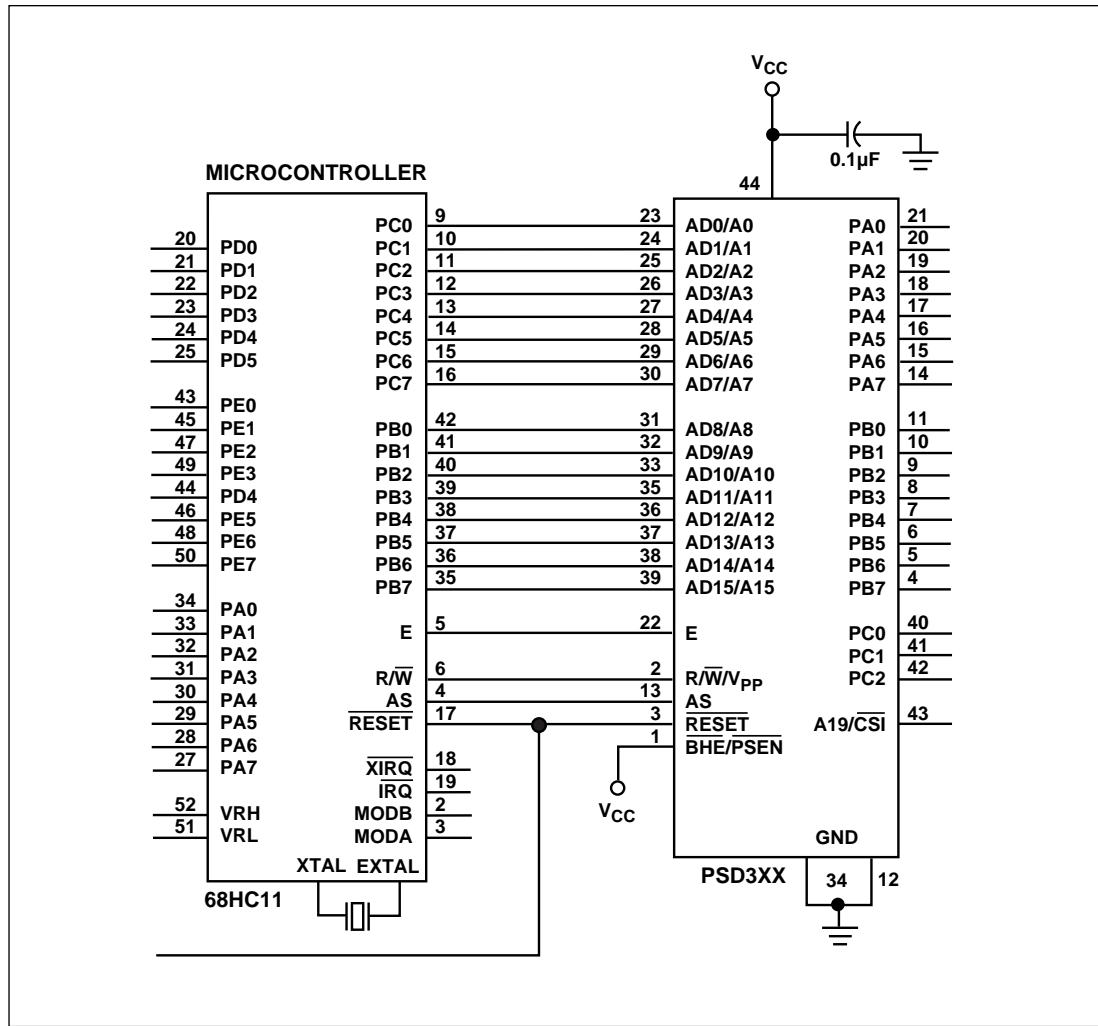
All other configuration bits may vary according to the application requirements.

System Applications

In Figure 13, the PSD3XX is configured to interface with Intel's 80C31, which is a 16-bit address/8-bit data bus microcontroller. Its data bus is multiplexed with the low-order address byte. The 80C31 uses signals \overline{RD} to read from data memory and \overline{PSEN} to read from code memory. It uses \overline{WR} to write into the data memory. It also uses active high reset and ALE signals. The rest of the configuration bits as well as the unconnected signals (not shown) are application specific and, thus, user dependent.

In Figure 14, the PSD3XX is configured to interface with Motorola's 68HC11, which is a 16-bit address/8-bit data bus microcontroller. Its data bus is multiplexed with the low-order address byte. The 68HC11 uses E and R/W signals to derive the read and write strobes. It uses the term AS (address strobe) for the address latch pulse. RESET is an active low signal. The rest of the configuration bits as well as the unconnected signals (not shown) are specific and, thus, user dependent.

Figure 14.
PSD3XX
Interface With
Motorola's
68HC11



The configuration bits for Figure 14 are:

CALE	0	COMB/SEP	0
CDATA	0	CRRWR	1
CADDRDAT	1	CEDS	0
CRESET	0		

All other configuration bits may vary according to the application requirements.

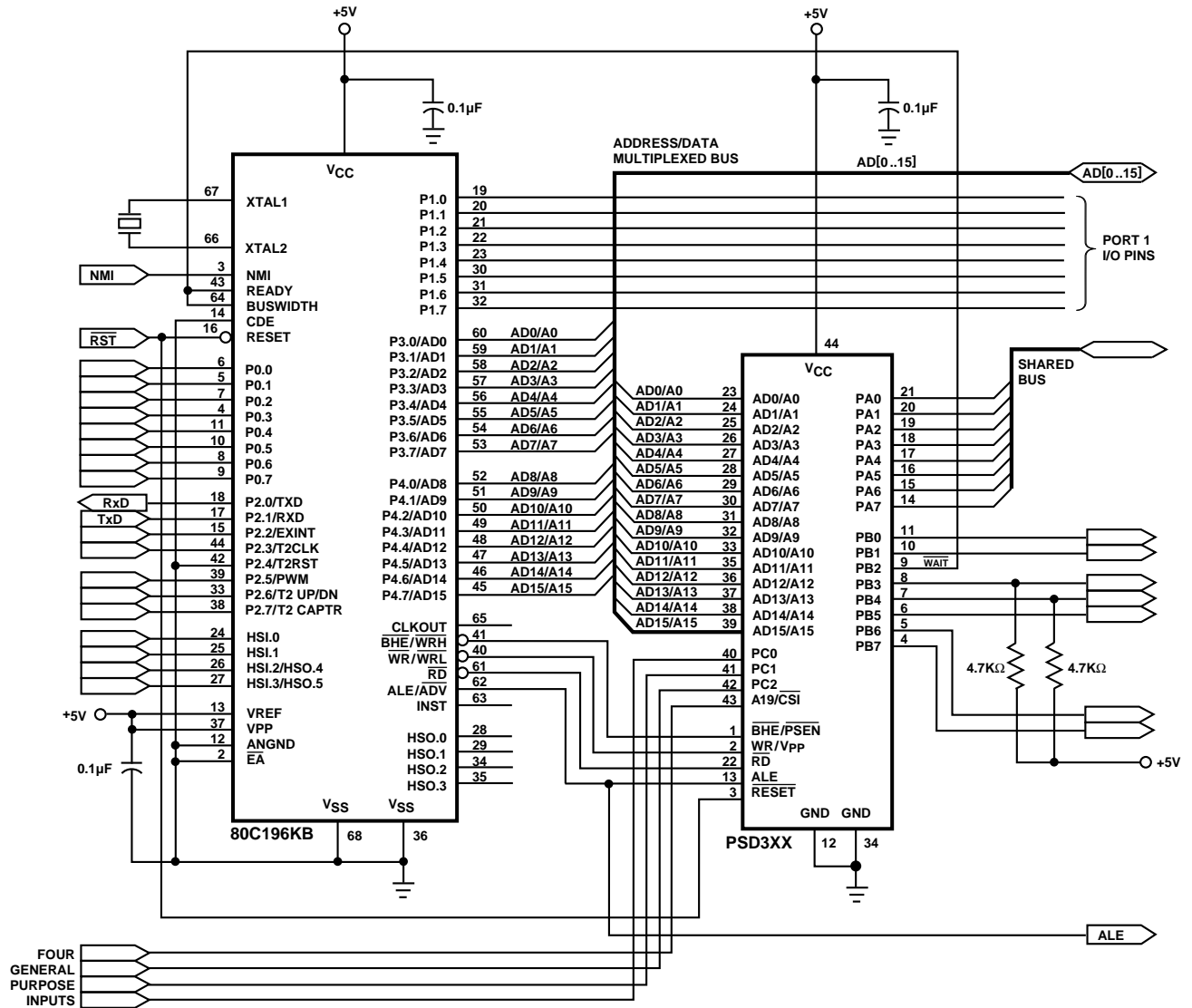
System Applications (Cont.)

In Figure 15, the PSD3XX is configured to work directly with Intel's 80C196KB microcontroller, which is a 16-bit address/16-bit data bus processor. Address and data lines multiplexed. In the example shown, all configuration bits are set. The PSD3XX is configured to use PC0, PC1, PC2, and $\overline{CSi}/A19$ as A16, A17, A18, and A19 inputs, respectively. These signals are independent of the ALE pulse (latch-transparent). They are used as four general-purpose logic inputs that take part in the PAD equations implementation.

Port A is configured to work in the special track mode, in which (for certain conditions) PA0-PA7 tracks lines AD0/A0-AD7/A7. Port B is configured to generate $\overline{CS0}-\overline{CS7}$. In this example, PB2 serves as a \overline{WAIT} signal that slows down the 80C196KB during the access of external peripherals. These 8-bit wide peripherals are connected to the shared bus of Port A. The \overline{WAIT} signal also drives the buswidth input of the microcontroller, so that every external peripheral cycle becomes an 8-bit data bus cycle. PB3 and PB4 are open-drain output signals; thus, they are pulled up externally.



Figure 15.
PSD3XX
Interface With
Intel's
80C196KB.



The configuration bits for Figure 15 are:

CALE	0	CSECURITY	Don't care
CDATA	1	CPCF2, CPCF1, CPCF0	0, 0, 0
CADDRDAT	1	CPACOD7-CPACOD0	00H
CPAF1	Don't care	CPBF7-CPBF0	00H
CPAF2	1	CPBCOD7-CPBCOD0	18H
CA19/CSI	1	CEDS	0
CRRWR	0	CADLOG3-CADLOG0	0H
COMB/SEP	0		
CADDHLT	0		
CRESET	0		



Security Mode

Security Mode in the PSD3XX locks the contents of the PAD A , PAD B and all the configuration bits. The EPROM, SRAM, and I/O contents can be accessed only through the PAD. The Security Mode can be set by the PSD Development or Programming software. In window packages, the mode is erasable through UV full part erasure. In the security mode, the PSD3XX contents cannot be copied on a programmer.

EPROM

The EPROM power consumption in the PSD is controlled by bit 3 in the PMMR0 – EPROM CMiser. Upon reset the CMiser bit is OFF. This will cause the EPROM to be ON at all times as long as CSI is enabled (low). The reason this mode is provided is to reduce the access time of the EPROM by 10 ns relative to the low power condition when CMiser is ON. If CSI is disabled (high) the EPROM will be deselected and will enter standby mode (OFF) overriding the state of the CMiser.

If CMiser is set (ON) then the EPROM will enter the standby mode when not selected. This condition can take place when CSI is high or when CSI is low and the EPROM is not accessed. For example, if the MCU is accessing the SRAM, the EPROM will be deselected and will be in low power mode.

An additional advantage of the CMiser is achieved when the PSD is configured in the by 8 mode (8 bit data bus). In this case an additional power savings is achieved in the EPROM (and also in the SRAM) by turning off 1/2 of the array even when the EPROM is accessed (the array is divided internally into odd and even arrays).

The power consumption for the different EPROM modes is given in the DC Characteristics table under I_{CC} (DC) EPROM Adder.

Absolute Maximum Ratings²⁶

<i>Symbol</i>	<i>Parameter</i>	<i>Condition</i>	<i>Min</i>	<i>Max</i>	<i>Unit</i>
T _{STG}	Storage Temperature	CERDIP	- 65	+ 150	°C
		PLASTIC	- 65	+ 125	°C
	Voltage on any Pin	With Respect to GND	- 0.6	+ 7	V
V _{PP}	Programming Supply Voltage	With Respect to GND	- 0.6	+ 14	V
V _{CC}	Supply Voltage	With Respect to GND	- 0.6	+ 7	V
	ESD Protection		>2000		V

NOTE: 26. Stresses above those listed under Absolute Maximum Ratings may cause permanent damage to the device. This is a stress rating only and functional operation of the device at these or any other conditions above those indicated in the operational sections of this specification is not implied. Exposure to Absolute Maximum Rating conditions for extended periods of time may affect device reliability.

Operating Range

<i>Range</i>	<i>Temperature</i>	<i>V_{CC}</i>	<i>V_{CC} Tolerance</i>
Commercial	0° C to +70°C	+ 5 V	± 10%
Industrial	-40° C to +85°C	+ 5 V	± 10%
Military	-55° C to +125°C	+ 5 V	± 10%

Recommended Operating Conditions

<i>Symbol</i>	<i>Parameter</i>	<i>Conditions</i>	<i>Min</i>	<i>Typ</i>	<i>Max</i>	<i>Unit</i>
V _{CC}	Supply Voltage	All Speeds	4.5	5	5.5	V
V _{CC}	Supply Voltage	PSD3XXL Versions Only, All Speeds	3.0	3.3	5.5	V



DC Characteristics – PSD3XX Versions (5V ± 10%)

Symbol	Parameter	Conditions				CMiser = 1 Subtract:			Unit
			Min	Typ	Max	Min	Typ	Max	
V _{IH}	High-Level Input Voltage	V _{CC} = 4.5 V to 5.5 V	2		V _{CC} + .1				V
V _{IL}	Low-Level Input Voltage	V _{CC} = 4.5 V to 5.5 V	-0.5		0.8				V
V _{OH}	Output High Voltage	I _{OH} = -20 µA, V _{CC} = 4.5 V	4.4	4.49					V
		I _{OH} = -2 mA, V _{CC} = 4.5 V	2.4	3.9					V
V _{OL}	Output Low Voltage	I _{OL} = 20 µA V _{CC} = 4.5 V		0.01	0.1				V
		I _{OL} = 8 mA V _{CC} = 4.5 V		0.15	0.45				V
I _{SB1}	V _{CC} Standby Current (CMOS) (Notes 27 and 29)	Comm'l		50	100				µA
		Ind/Mil		75	150				µA
I _{CC1}	Active Current (CMOS) (No Internal Memory Block Selected) (Notes 27, 28a and 30)	Comm'l (Note 31)		16	35		7	10	mA
		Comm'l (Note 32)		28	50		7	10	mA
		Ind/Mil (Note 31)		16	45		7	10	mA
		Ind/Mil (Note 32)		28	60		7	10	mA
I _{CC2}	Active Current (CMOS) (EPROM Block Selected) (Notes 27, 28a and 30)	Comm'l (Note 31)		16	35		0/5*	0/7*	mA
		Comm'l (Note 32)		28	50		0/5*	0/7*	mA
		Ind/Mil (Note 31)		16	45		0/5*	0/7*	mA
		Ind/Mil (Note 32)		28	60		0/5*	0/7*	mA
I _{CC3}	Active Current (CMOS) (SRAM Block Selected) (Notes 27, 28a and 30)	Comm'l (Note 31)		47	80		7	10	mA
		Comm'l (Note 32)		59	95		7	10	mA
		Ind/Mil (Note 31)		47	100		7	10	mA
		Ind/Mil (Note 32)		59	115		7	10	mA
I _{LI}	Input Leakage Current	V _{IN} = 5.5 V or GND	-1	±0.1	1				µA
I _{LO}	Output Leakage Current	V _{OUT} = 5.5 V or GND	-10	±5	10				µA

NOTES: 27. CMOS inputs: GND ± 0.3 V or V_{CC} ± 0.3V.

28. TTL inputs: V_{IL} ≤ 0.8 V, V_{IH} ≥ 2.0 V.

28a. I_{OUT} = 0 mA.

29. CSI/A19 is high and the part is in a power-down configuration mode.

30. Add 3.0 mA/MHz for AC power component (power = AC + DC).

31. Ten (10) PAD product terms active. (Add 380 µA per product term, typical, or 480 µA per product term maximum.)

32. Forty-one (41) PAD product terms active.

*The zero value is for 16-bit configurations. The other values are for 8-bit configurations.

DC Characteristics – PSD3XXL Low-Power Versions (3.3V ± 10%)

Symbol	Parameter	Conditions				CMiser = 1 Subtract:			Unit
			Min	Typ	Max	Min	Typ	Max	
V _{IH}	High-Level Input Voltage	V _{CC} = 3.0 V to 5.5 V	0.7 V _{CC}		V _{CC} + 0.5				V
V _{IL}	Low-Level Input Voltage	V _{CC} = 3.0 V to 5.5 V	-0.5		0.3 V _{CC}				V
V _{OH}	Output High Voltage	I _{OH} = -20 μA, V _{CC} = 3.0 V	2.9	2.99					V
		I _{OH} = -1 mA, V _{CC} = 3.0 V	2.4	2.6					V
V _{OL}	Output Low Voltage	I _{OL} = 20 μA, V _{CC} = 3.0 V		0.01	0.1				V
		I _{OL} = 4 mA, V _{CC} = 3.0 V		0.15	0.4				V
I _{SB1}	V _{CC} Standby Current (CMOS) (Notes 33 and 34)	V _{CC} = 3.3 V		1	5				μA
I _{CC1}	Active Current (CMOS) (No Internal Memory Block Selected) (Notes 33, 33a and 35)	V _{CC} = 3.3 V (Note 36)		5	11		3.0	4	mA
		V _{CC} = 3.3 V (Note 37)		9	17		3.0	4	mA
I _{CC2}	Active Current (CMOS) (EPROM Block Selected) (Notes 33, 33a and 35)	V _{CC} = 3.3 V (Notes 36 and 38)		5	11		0/2*	0/3*	mA
		V _{CC} = 3.3 V (Notes 37 and 38)		9	17		0/2*	0/3*	mA
I _{CC3}	Active Current (CMOS) (SRAM Block Selected) (Notes 33, 33a and 35)	V _{CC} = 3.3 V (Notes 36 and 38)		16	29		3	4	mA
		V _{CC} = 3.3 V (Notes 37 and 38)		21	35		3	4	mA
I _{LI}	Input Leakage Current	V _{IN} = V _{CC} or GND	-1	±0.1	1				μA
I _{LO}	Output Leakage Current	V _{OUT} = V _{CC} or GND	-10	±5	10				μA

NOTES: 33. CMOS inputs: GND ± 0.3 V or V_{CC} ± 0.3V.

33a. I_{OUT} = 0 mA.

34. $\overline{\text{CS}}/\text{A19}$ is high and the part is in a power-down configuration mode.

35. AC power component (power = AC + DC).

– For 3.3 V operation, add 2.0 mA/MHz.

– For 5.0 V operation, add 3.0 mA/MHz.

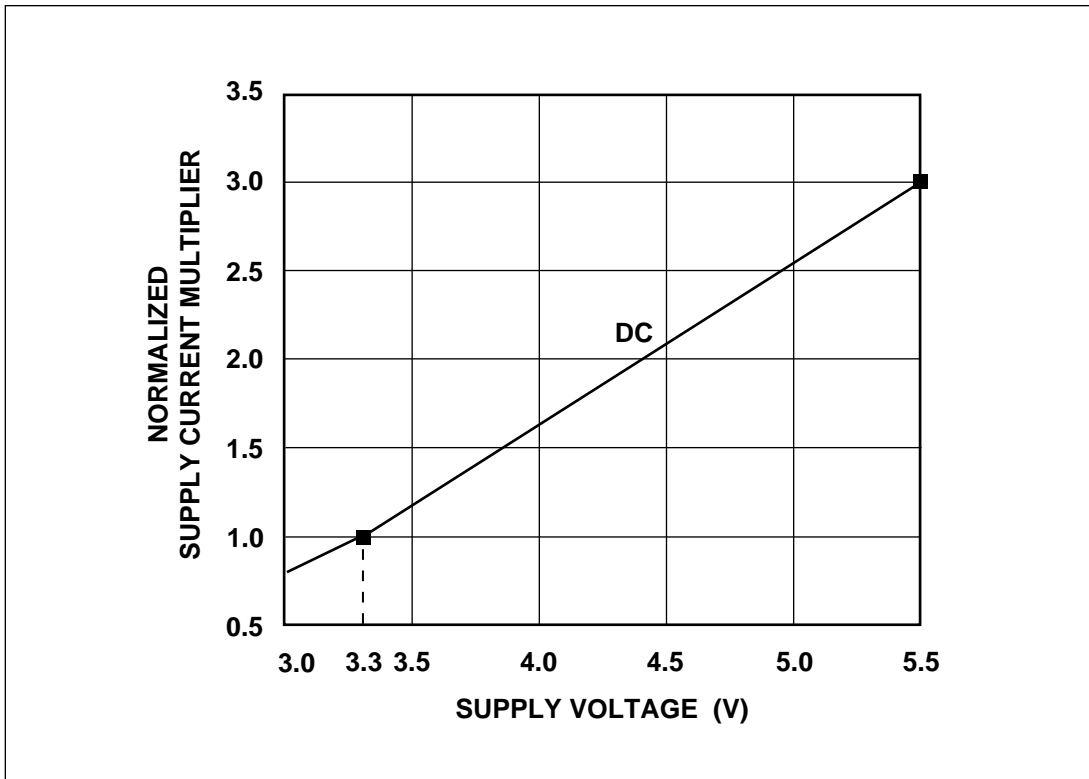
36. Ten (10) PAD product terms active. (Add 190 μA per product term, typical, or 240 μA per product term maximum.)

37. Forty (40) PAD product terms active.

38. In 8-bit mode, an additional 3 mA Max can be saved under CMiser.

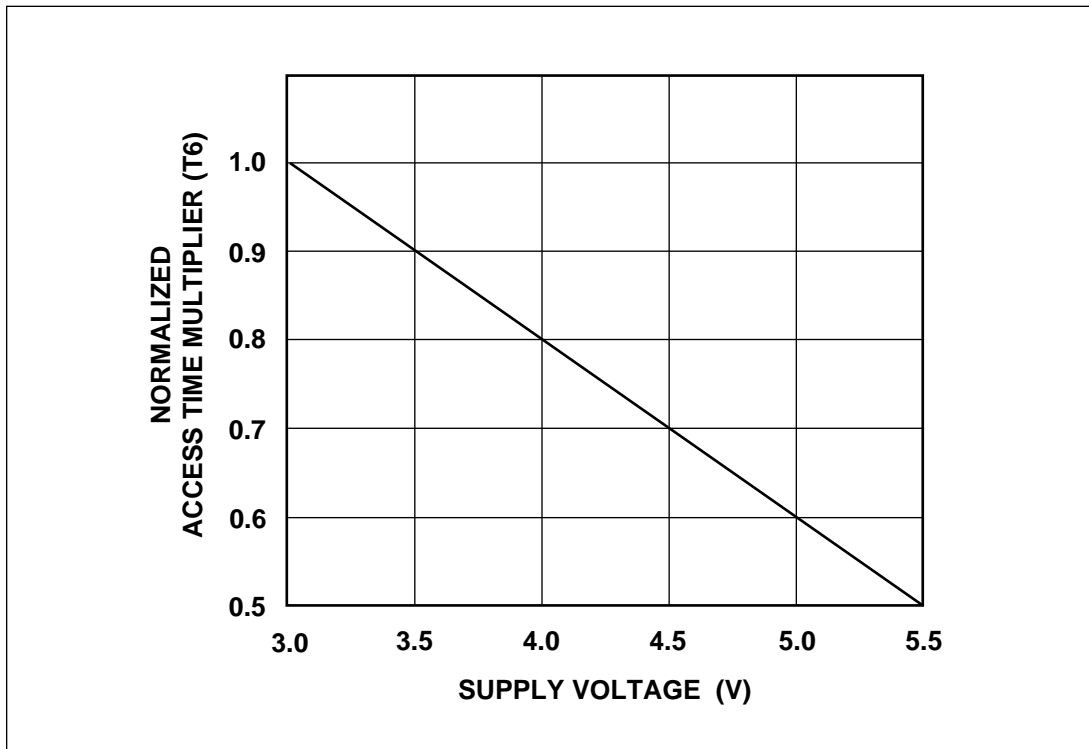
*The zero value is for 16-bit configurations. The other values are for 8-bit configurations.

Figure 16.
Normalized
Supply Current
vs.
Supply Voltage
(PSD3XXL
Low-Power
Versions)



The Normalized Supply Current vs. Supply Voltage graph shown above, provides a multiplier for any I_{SB} or I_{CC} value in the D.C. Characteristics table. As noted, it is normalized for a supply voltage of 3.3 volts (PSD3XXL versions). To use, calculate the supply current at 3.3 volts for your operation configuration using the D.C. Characteristics table. Then multiply that value by the Supply Current Multiplier for the supply voltage actually being used.

Figure 16a.
Normalized
Access Time
Multiplier
vs.
Supply Voltage
(PSD3XXL
Low-Power
Versions)



AC Characteristics – PSD3XX Versions (5V ± 10%)

Symbol	Parameter	-70		-90		-12		-15		-20		CMiser On = Add	Unit
		Min	Max	Min	Max	Min	Max	Min	Max	Min	Max		
T1	ALE or AS Pulse Width	18		20		30		40		50		0	ns
T2	Address Set-up Time	5		5		9		12		15		0	ns
T3	Address Hold Time	7		8		9		10		15		0	ns
T4	Leading Edge of Read to Data Active	0		0		0		0		0		0	ns
T5	ALE Valid to Data Valid		80		100		140		170		200	10	ns
T6	Address Valid to Data Valid		70		90		120		150		210	10	ns
T7	\overline{CS} Active to Data Valid		80		100		150		160		200	10	ns
T8	Leading Edge of Read to Data Valid		20		32		36		45		50	0	ns
T8A	Leading Edge of Read to Data Valid in 8031-Based Architecture Operating with PSEN and RD in Separate Mode		32		32		38		55		60	0	ns
T9	Read Data Hold Time	0		0		0		0		0		0	ns
T10	Trailing Edge of Read to Data High-Z (PSD3X1)		20		35		35		40		45	0	ns
	Trailing Edge of Read to Data High-Z (PSD3X2/3X3/3X4R)		20		30		35		40		45	0	ns
T11	Trailing Edge of ALE or AS to Leading Edge of Write	0		0		0		0		0		0	ns
T12	\overline{RD} , E, \overline{PSEN} , or \overline{DS} Pulse Width	35		40		45		60		75		0	ns
T12A	\overline{WR} Pulse Width	18		20		25		35		45		0	ns
T13	Trailing Edge of Write or Read to Leading Edge of ALE or AS	5		5		5		5		5		0	ns
T14	Address Valid to Trailing Edge of Write	70		90		120		150		200		0	ns
T15	\overline{CS} Active to Trailing Edge of Write	80		100		130		160		200		0	ns
T16	Write Data Set-up Time	18		20		25		30		40		0	ns



AC Characteristics – PSD3XX Versions (5V ± 10%) (Cont.)

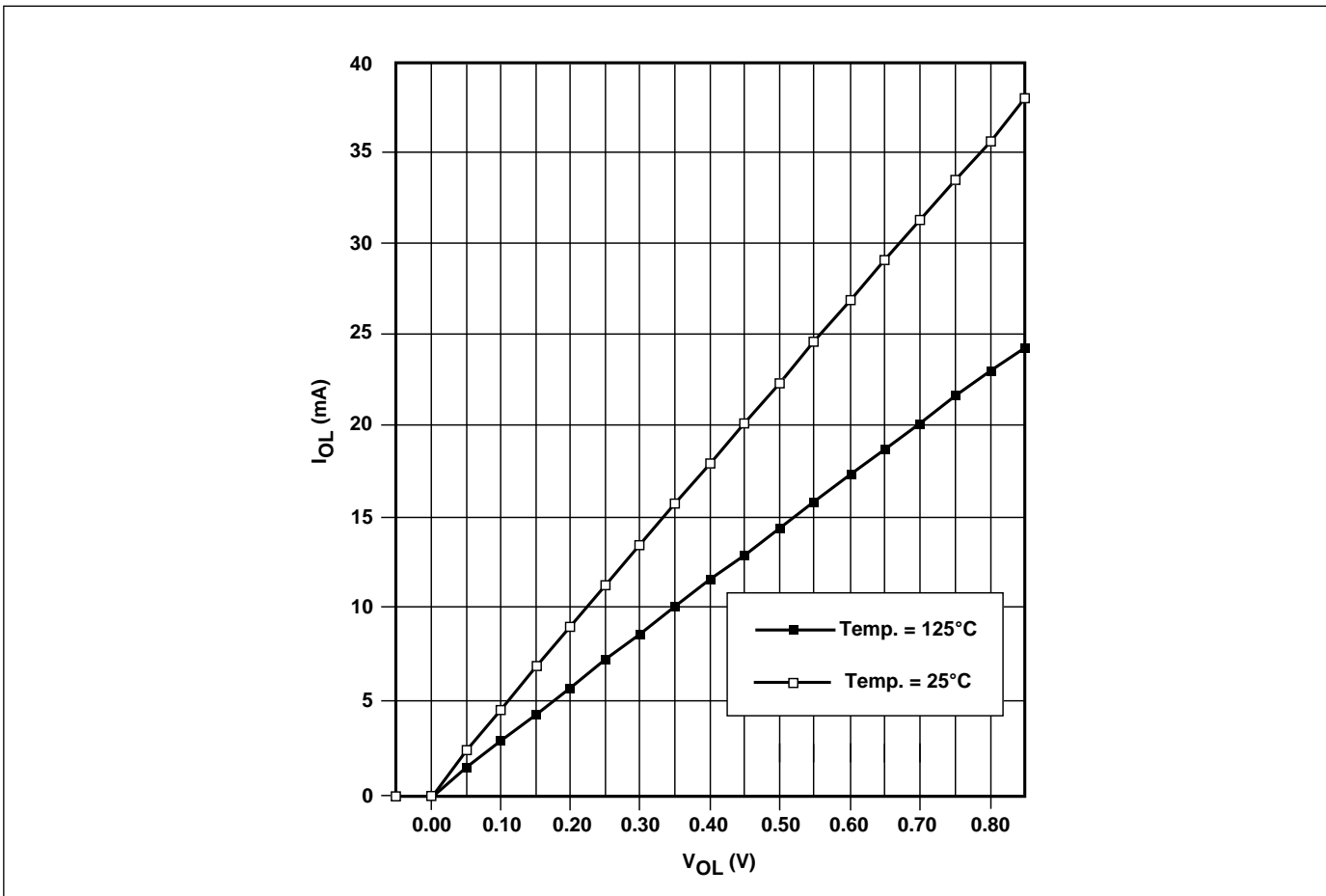
Symbol	Parameter	-70		-90		-12		-15		-20		CMiser On = Add	Unit
		Min	Max	Min	Max	Min	Max	Min	Max	Min	Max		
T17	Write Data Hold Time	5		5		5		10		15		0	ns
T18	Port to Data Out Valid Propagation Delay		25		28		30		35		45	0	ns
T19	Port Input Hold Time	0		0		0		0		0		0	ns
T20	Trailing Edge of Write to Port Output Valid		30		35		40		50		60	0	ns
T21	ADi or Control to $\overline{\text{CSO}}_i$ Valid	6	20	6	25	6	30	6	35	5	45	10	ns
T22	ADi or Control to $\overline{\text{CSO}}_i$ Invalid	5	20	5	25	5	30	4	35	4	45	10	ns
T23	Track Mode Address Propagation Delay: CSADOUT1 Already True		22		22		22		22		28	0	ns
	Latched Address Outputs, Port A		22		22		22		22		28	0	ns
T23A	Track Mode Address Propagation Delay: CSADOUT1 Becomes True During ALE or AS		33		33		33		40		50	10	ns
T24	Track Mode Trailing Edge of ALE or AS to Address High-Z		30		32		32		35		40	0	ns
T25	Track Mode Read Propagation Delay		27		29		29		29		35	0	ns
T26	Track Mode Read Hold Time	5	29	11	29	11	29	11	29	11	35	0	ns
T27	Track Mode Write Cycle, Data Propagation Delay		18		20		20		20		30	0	ns
T28	Track Mode Write Cycle, Write to Data Propagation Delay	6	30	8	30	8	30	9	40	9	55	0	ns
T29	Hold Time of Port A Valid During Write $\overline{\text{CSO}}_i$ Trailing Edge	2		2		2		2		2		0	ns
T30	$\overline{\text{CS}}_i$ Active to $\overline{\text{CSO}}_i$ Active (PSD3X1)	8	37	9	40	9	45	9	45	8	60	0	ns
	$\overline{\text{CS}}_i$ Active to $\overline{\text{CSO}}_i$ Active (PSD3X2/3X3/3X4R)	8	37	9	40	9	45	9	50	8	60	0	ns
T31	$\overline{\text{CS}}_i$ Inactive to $\overline{\text{CSO}}_i$ Inactive	8	37	9	40	9	45	9	45	8	60	0	ns
T32	Direct PAD Input as Hold Time	0		0		0		0		0		0	ns

AC Characteristics – PSD3XX Versions (5V ± 10%) (Cont.)

Symbol	Parameter	-70		-90		-12		-15		-20		CMiser On = Add	Unit
		Min	Max	Min	Max	Min	Max	Min	Max	Min	Max		
T33	R/W Active to E High (PSD3X1)	18		20		20		30		40		0	ns
	R/W Active to E or \overline{DS} Start (PSD3X2/3X3/3X4R)	18		20		20		30		40		0	ns
T34	E End to R/W (PSD3X1)	18		20		20		30		40		0	ns
	E or \overline{DS} End to R/W (PSD3X2/3X3/3X4R)	18		20		20		30		40		0	ns
T35	AS Inactive to E high	0		0		0		0		0		0	ns
T36	Address to Leading Edge of Write	18		20		20		25		30		0	ns

- NOTES:** 39. ADi = any address line.
 40. $\overline{CS0i}$ = any of the chip-select output signals coming through Port B ($\overline{CS0}$ – $\overline{CS7}$) or through Port C ($\overline{CS8}$ – $\overline{CS10}$).
 41. Direct PAD input = any of the following direct PAD input lines: $\overline{CS1/A19}$ as transparent A19, $\overline{RD/E/DS}$, \overline{WR} or $\overline{R/W}$, transparent PC0–PC2, ALE (or AS).
 42. Control signals $\overline{RD/E/DS}$ or \overline{WR} or $\overline{R/W}$.

Figure 17. PSD3XX I_{OL} vs. V_{OL}



AC Characteristics – PSD3XXL Low-Power Versions (3.3V ± 10%, Note 43)

Symbol	Parameter	-15		-20		-25		-30		CMiser = 1 Add:	Unit
		Min	Max	Min	Max	Min	Max	Min	Max		
T1	ALE or AS Pulse Width	40		50		75		80			ns
T2	Address Set-up Time	12		15		30		35			ns
T3	Address Hold Time	10		15		20		30		0	ns
T4	Leading Edge of Read to Data Active	0		0		0		0		0	ns
T5	ALE Valid to Data Valid		160		200		250		300	20	ns
T6	Address Valid to Data Valid		150		200		250		300	20	ns
T7	$\overline{\text{CSI}}$ Active to Data Valid		160		210		275		325	20	ns
T8	Leading Edge of Read to Data Valid		40		45		90		95	0	ns
T8A	Leading Edge of Read to Data Valid		60		65		90		95	0	ns
T9	Read Data Hold Time	0		0		0		0		0	ns
T10	Trailing Edge of Read to Data High-Z		40		45		55		60	0	ns
T11	Trailing Edge of ALE or AS to Leading Edge of Write	0		0			40		45		ns
T12	$\overline{\text{RD}}$, $\overline{\text{E}}$, $\overline{\text{PSEN}}$, $\overline{\text{DS}}$ Pulse Width	60		75		100		110		0	ns
T12A	$\overline{\text{WR}}$ Pulse Width	35		45		90		95		0	ns
T13	Trailing Edge of Write or Read to Leading Edge of ALE or AS	5		5		5		5		0	ns
T14	Address Valid to Trailing Edge of Write	150		200		250		300		0	ns
T15	$\overline{\text{CSI}}$ Active to Trailing Edge of Write	160		200		275		325		0	ns
T16	Write Data Set-up Time	30		40		60		65		0	ns
T17	Write Data Hold Time	10		12		25		30		0	ns
T18	Port to Data Out Valid Propagation Delay		40		45		70		75	0	ns
T19	Port Input Hold Time	0		0		0		0		0	ns
T20	Trailing Edge of Write to Port Output Valid		50		60		100		110	0	ns
T21	ADi or Control to $\overline{\text{CSO}}_i$ Valid	6	45	5	50	6	80	5	85	0	ns
T22	ADi or Control to $\overline{\text{CSO}}_i$ Invalid	4	45	4	50	4	80	4	85	0	ns

NOTE: 43. These AC Characteristics are for $V_{CC} = 3.0 - 3.6V$.



AC Characteristics – PSD3XXL Low-Power Versions (3.3V ± 10%, Note 43) (Cont.)

Symbol	Parameter	-15		-20		-25		-30		CMiser = 1 Add:	Unit
		Min	Max	Min	Max	Min	Max	Min	Max		
T23	Track Mode Address Propagation Delay: CSADOUT1 Already True		50		60		70		75	0	ns
	Latched Address Outputs, Port A		50		60		70		75	0	
T23A	Track Mode Address Propagation Delay: CSADOUT1 Becomes True During ALE or AS		70		80		100		110	0	ns
T24	Track Mode Trailing Edge of ALE or AS to Address High-Z		45		55		60		65	0	ns
T25	Track Mode Read Propagation Delay		40		50		70		75	0	ns
T26	Track Mode Read Hold Time	10	70	10	70	10	70	10	75		ns
T27	Track Mode Write Cycle, Data Propagation Delay		40		50		60		65	0	ns
T28	Track Mode Write Cycle, Write to Data Propagation Delay	8	65	8	75	9	80	9	85	0	ns
T29	Hold Time of Port A Valid During Write CS _O _i Trailing Edge	2		3		4		4		0	ns
T30	$\overline{\text{CS}}_i$ Active to $\overline{\text{CS}}_{O_i}$ Active	9	55	9	70	9	110	8	120	0	ns
T31	$\overline{\text{CS}}_i$ Inactive to $\overline{\text{CS}}_{O_i}$ Inactive	9	55	9	70	9	110	8	120	0	ns
T32	Direct PAD Input as Hold Time	0		0		0		0		0	ns
T33	R/ $\overline{\text{W}}$ Active to E or $\overline{\text{DS}}$ Start	30		40		60		65		0	ns
T34	E or $\overline{\text{DS}}$ End to R/ $\overline{\text{W}}$	30		40		60		65		0	ns
T35	AS Inactive to E high	0		0		40		45		0	ns
T36	Address to Leading Edge of Write	25		30		50		60		0	ns

NOTES: 44. AD_i = any address line.

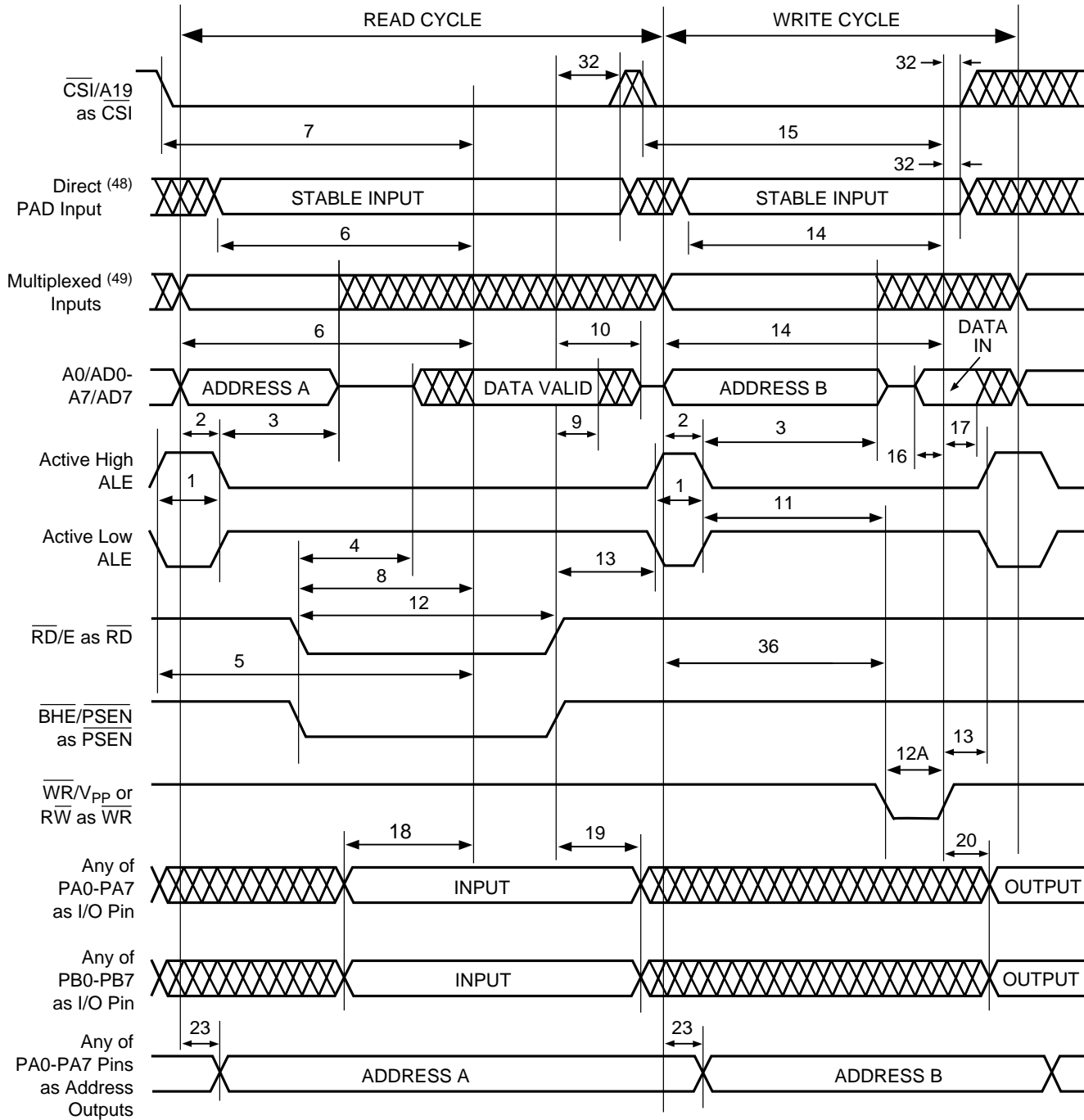
45. $\overline{\text{CS}}_{O_i}$ = any of the chip-select output signals coming through Port B ($\overline{\text{CS}}_0$ – $\overline{\text{CS}}_7$) or through Port C ($\overline{\text{CS}}_8$ – $\overline{\text{CS}}_{10}$).

46. Direct PAD input = any of the following direct PAD input lines: $\overline{\text{CS}}_i/\text{A}19$ as transparent A19, $\overline{\text{RD}}/\text{E}/\overline{\text{DS}}$, $\overline{\text{WR}}$ or R/ $\overline{\text{W}}$, transparent PC0–PC2, ALE (or AS).

47. Control signals $\overline{\text{RD}}/\text{E}/\overline{\text{DS}}$ or $\overline{\text{WR}}$ or R/ $\overline{\text{W}}$.



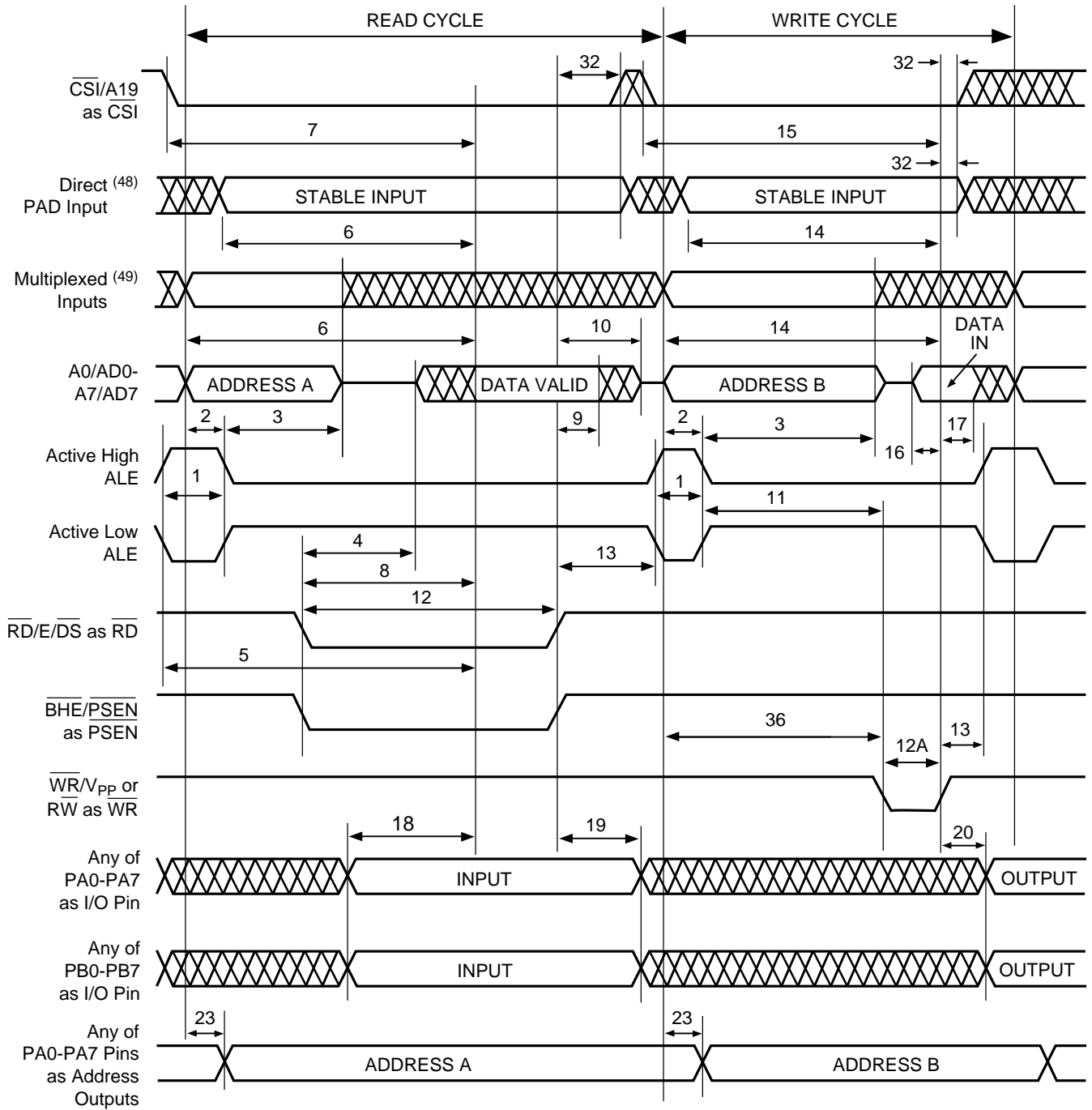
Figure 18.
Timing of 8-Bit
Multiplexed
Address/Data
Bus, CRRWR = 0
(PSD3X1)



See referenced notes on page 2-61.



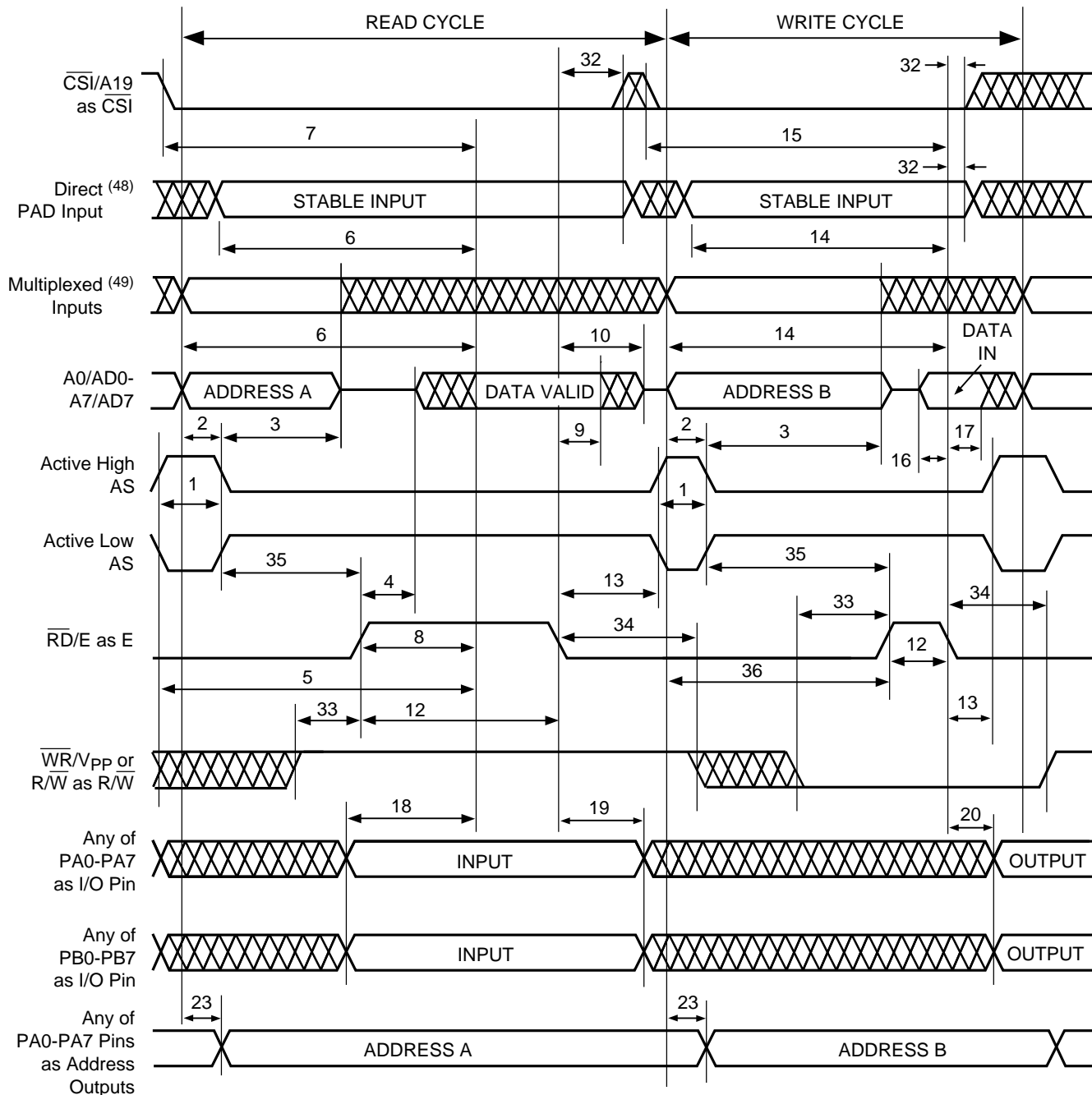
Figure 19.
Timing of 8-Bit
Multiplexed
Address/Data Bus,
CRRWR = 0
(PSD3X2/3X3/3X4R)



See referenced notes on page 2-61.



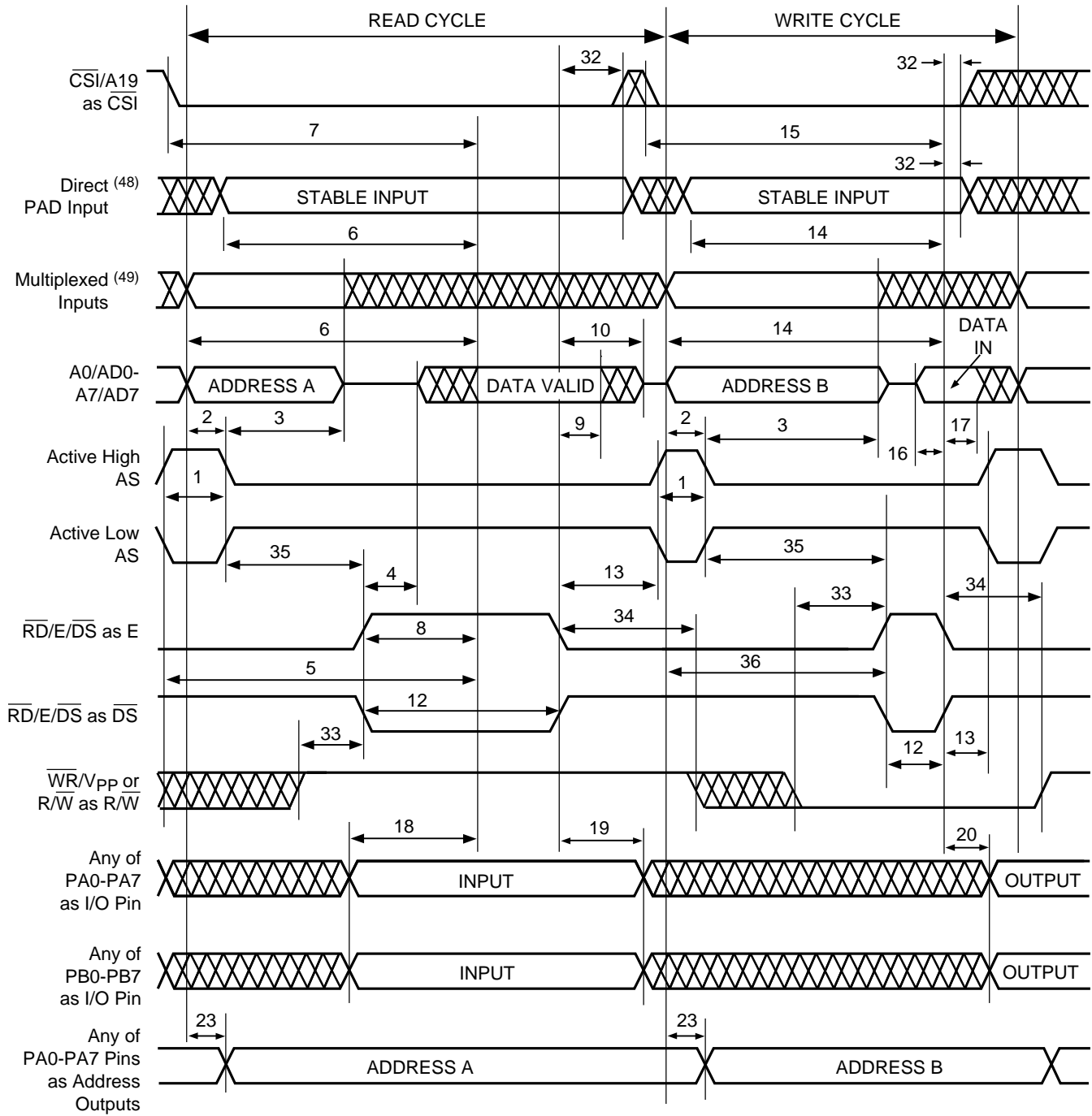
Figure 20.
Timing of 8-Bit
Multiplexed
Address/Data
Bus, CRRWR = 1
(PSD3X1)



See referenced notes on page 2-61.



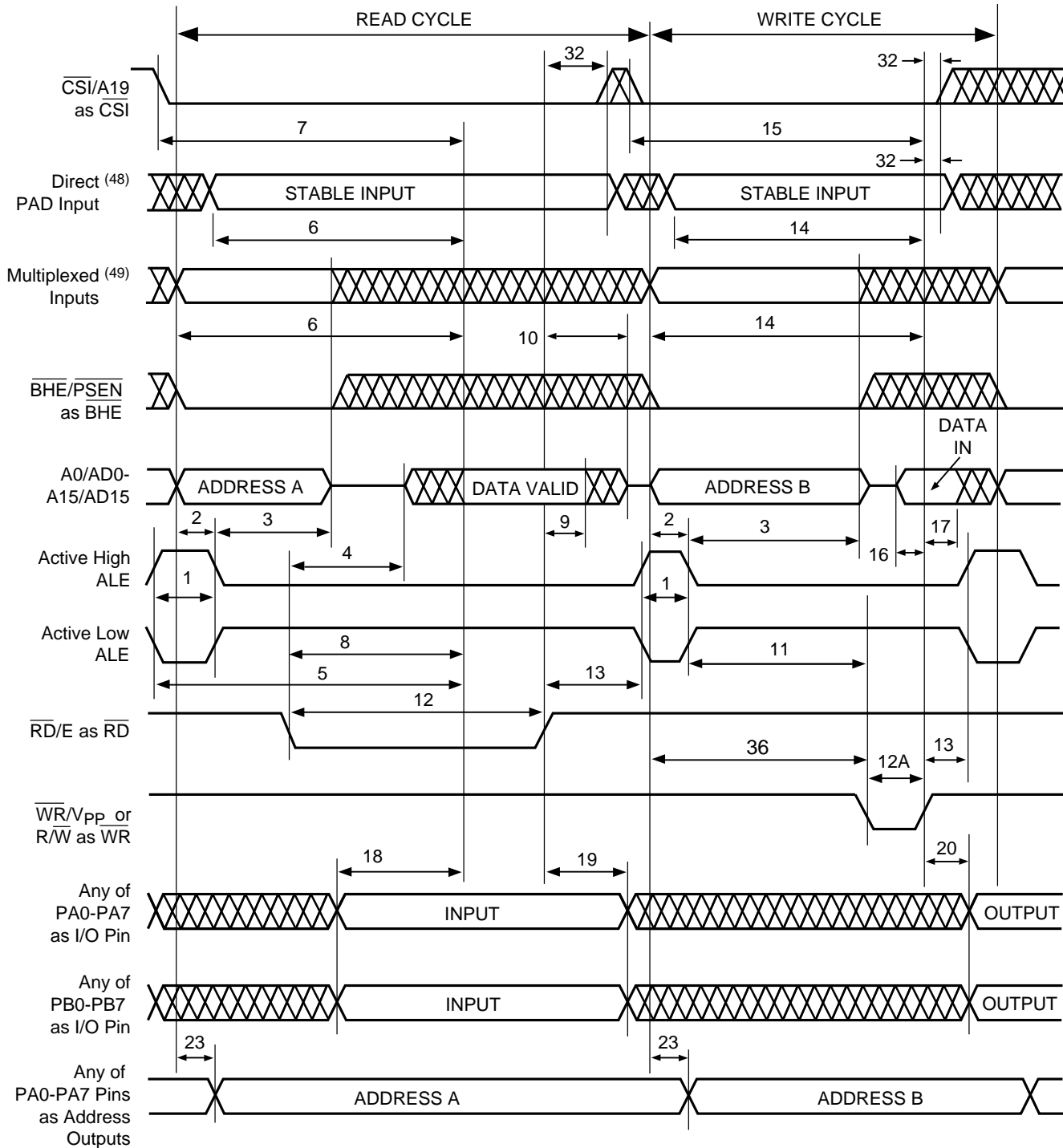
Figure 21.
Timing of 8-Bit
Multiplexed
Address/Data Bus,
CRRWR = 1
(PSD3X2/3X3/3X4R)



See referenced notes on page 2-61.



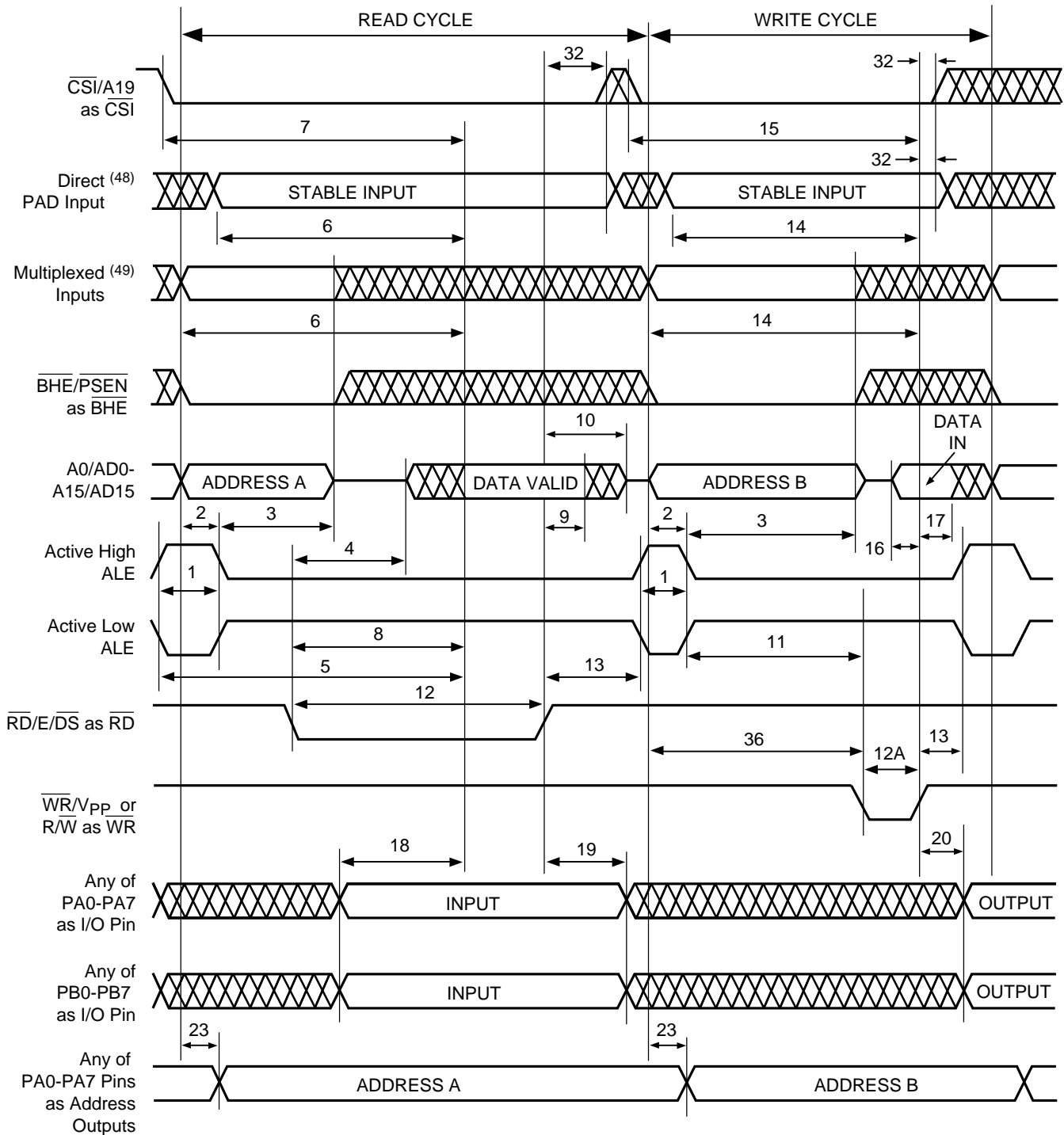
Figure 22.
Timing of 16-Bit
Multiplexed
Address/Data
Bus, CRRWR = 0
(PSD3X1)



See referenced notes on page 2-61.



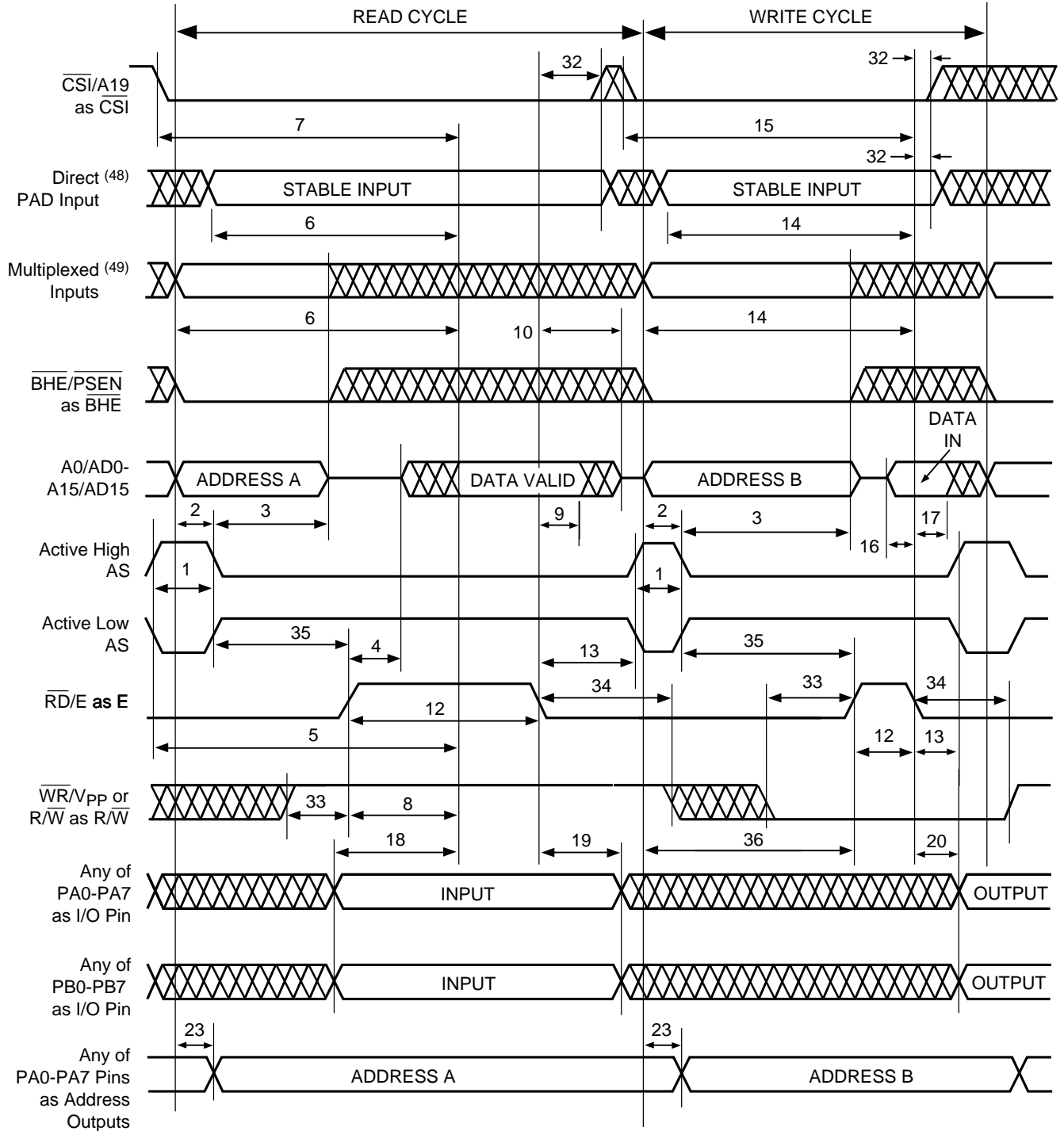
Figure 23.
Timing of 16-Bit
Multiplexed
Address/Data Bus,
CRRWR = 0
(PSD3X2/3X3/3X4R)



See referenced notes on page 2-61.



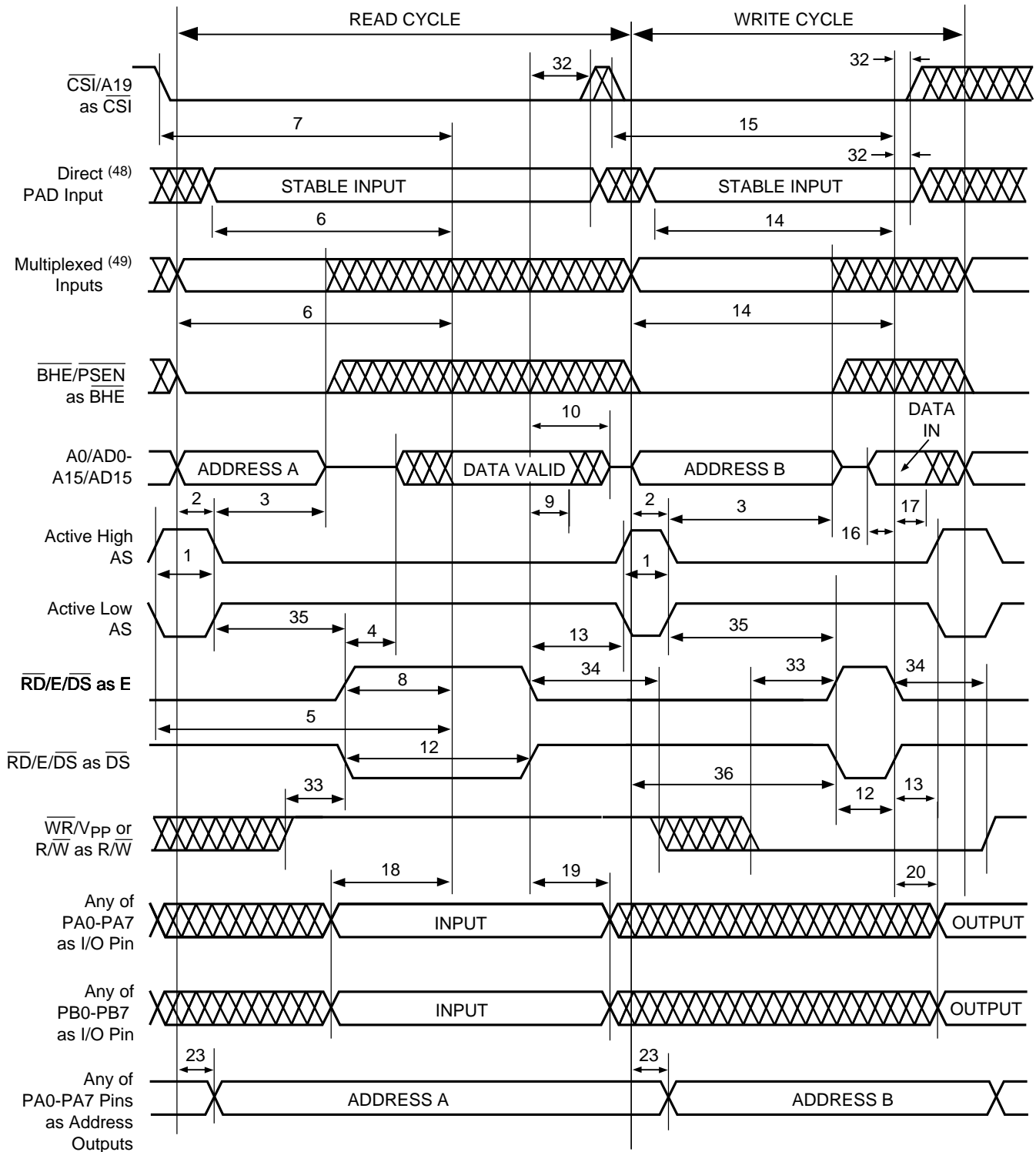
Figure 24.
Timing of 16-Bit
Multiplexed
Address/Data
Bus, CRRWR = 1
(PSD3X1)



See referenced notes on page 2-61.



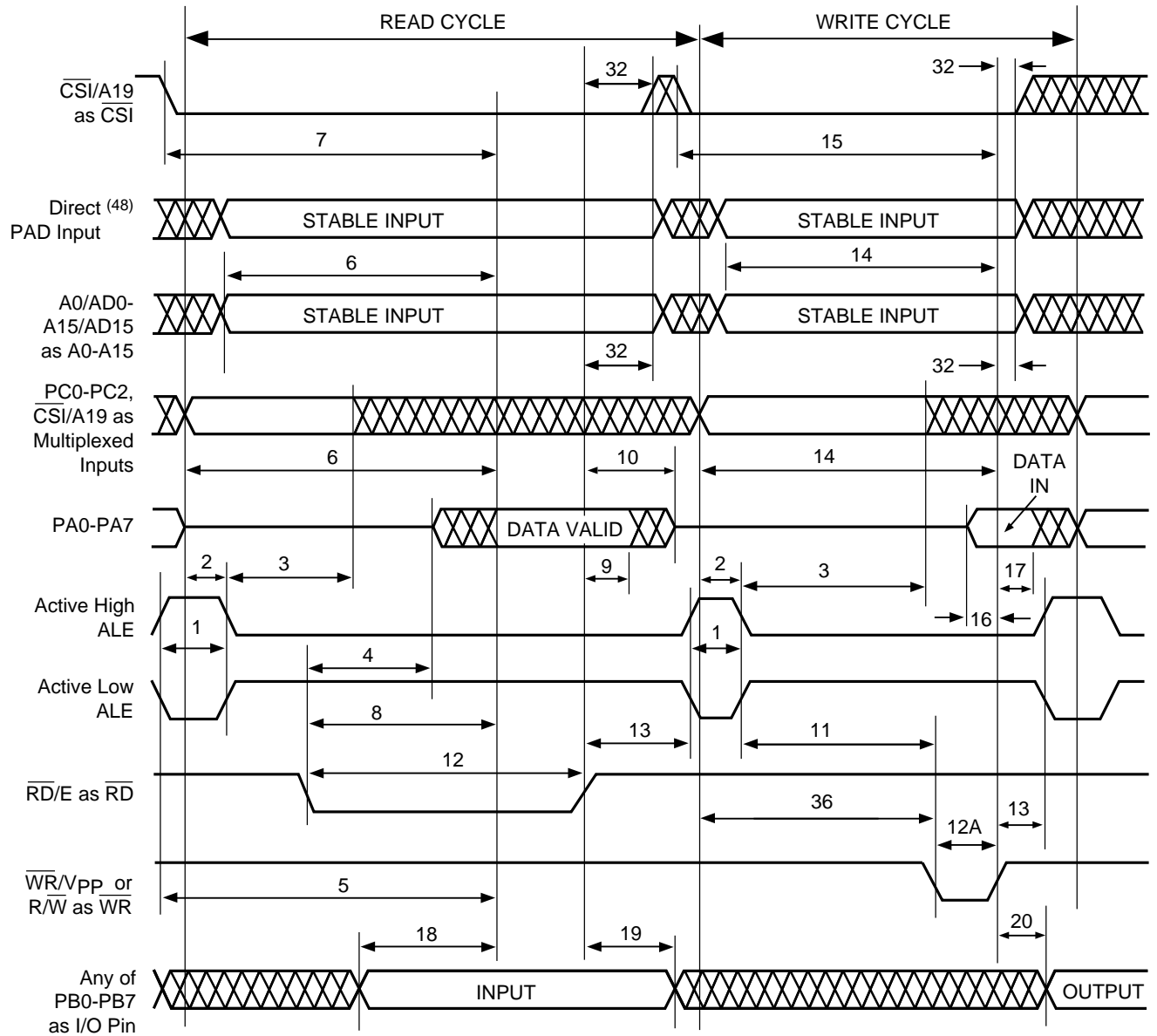
Figure 25.
Timing of 16-Bit
Multiplexed
Address/Data Bus,
CRRWR = 1
(PSD3X2/3X3/3X4R)



See referenced notes on page 2-61.



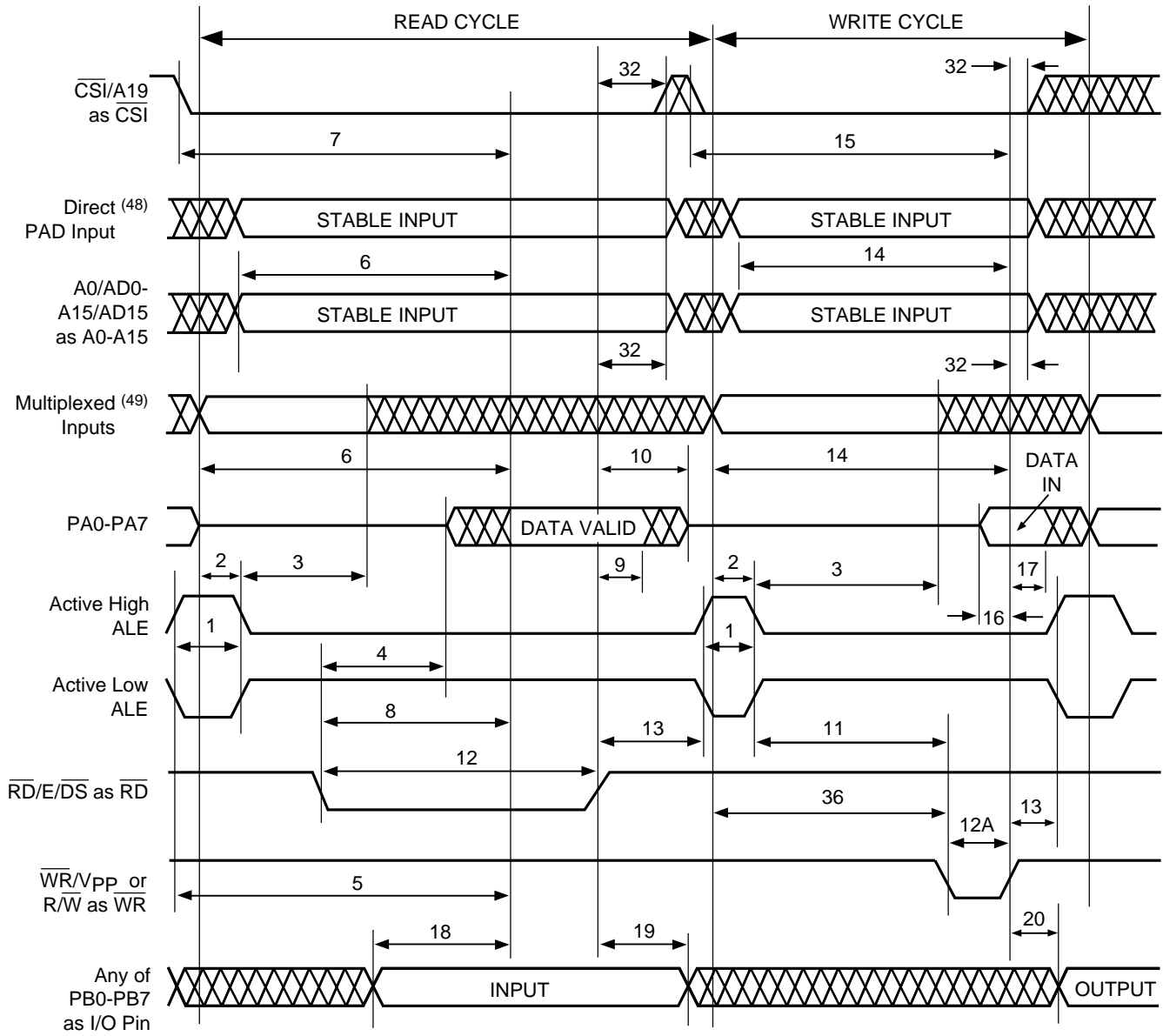
Figure 26.
Timing of 8-Bit
Non-Multiplexed
Address/Data
Bus, CRRWR = 0
(PSD3X1)



See referenced notes on page 2-61.



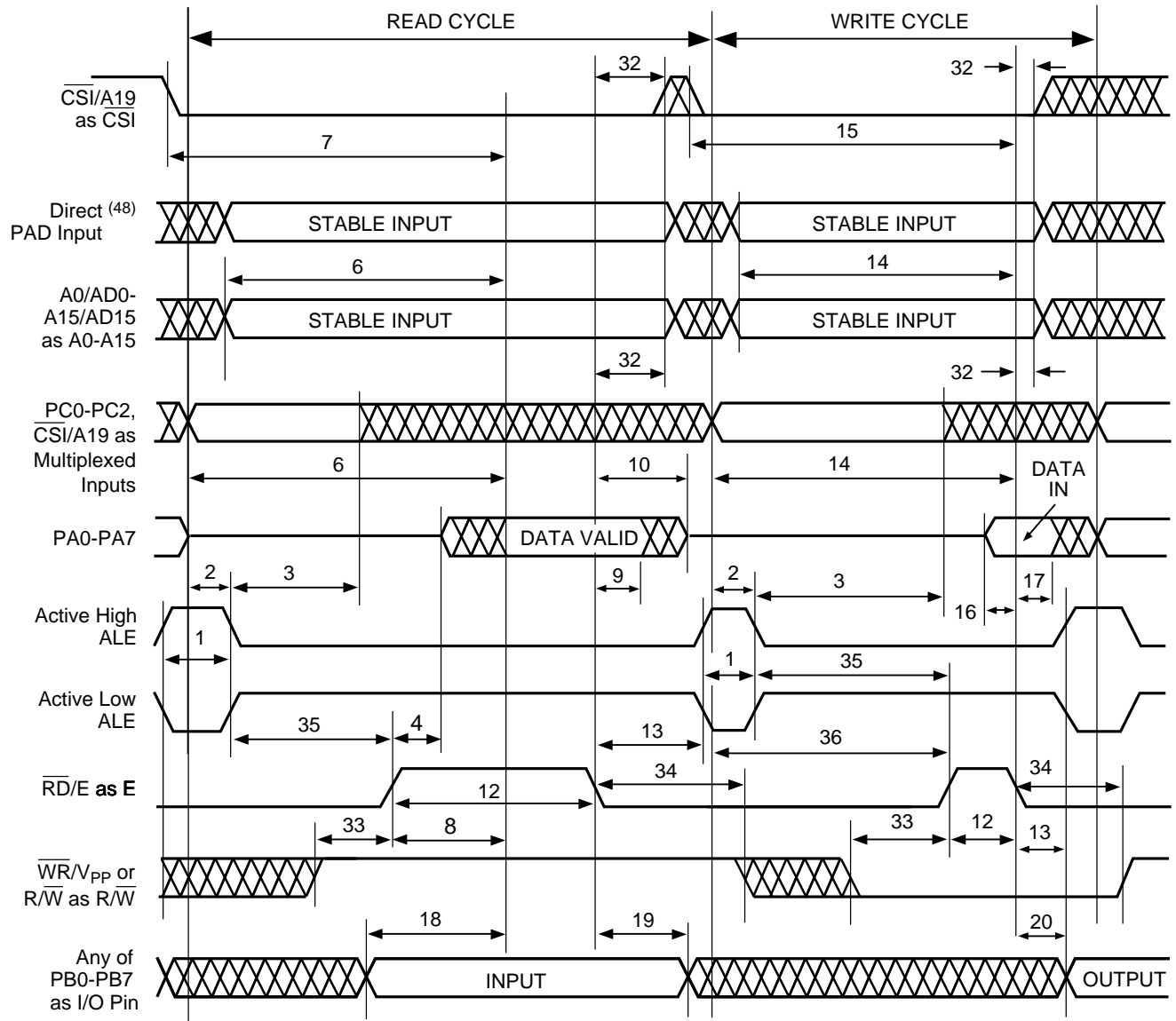
Figure 27.
Timing of 8-Bit
Non-Multiplexed
Address/Data Bus,
CRRWR = 0
(PSD3X2/3X3/3X4R)



See referenced notes on page 2-61.



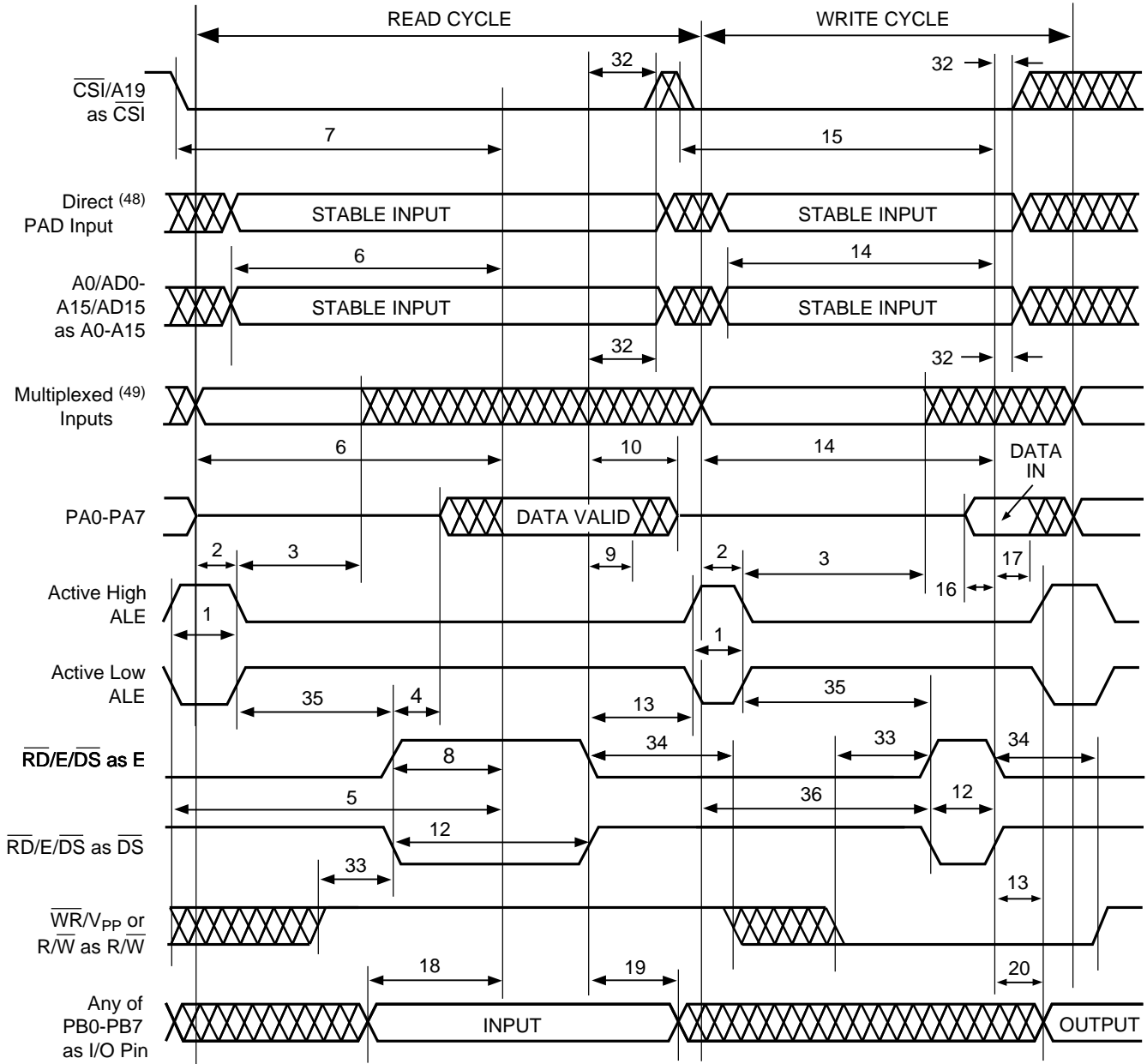
Figure 28.
Timing of 8-Bit
Non-Multiplexed
Address/Data
Bus, CRRWR = 1
(PSD3X1)



See referenced notes on page 2-61.



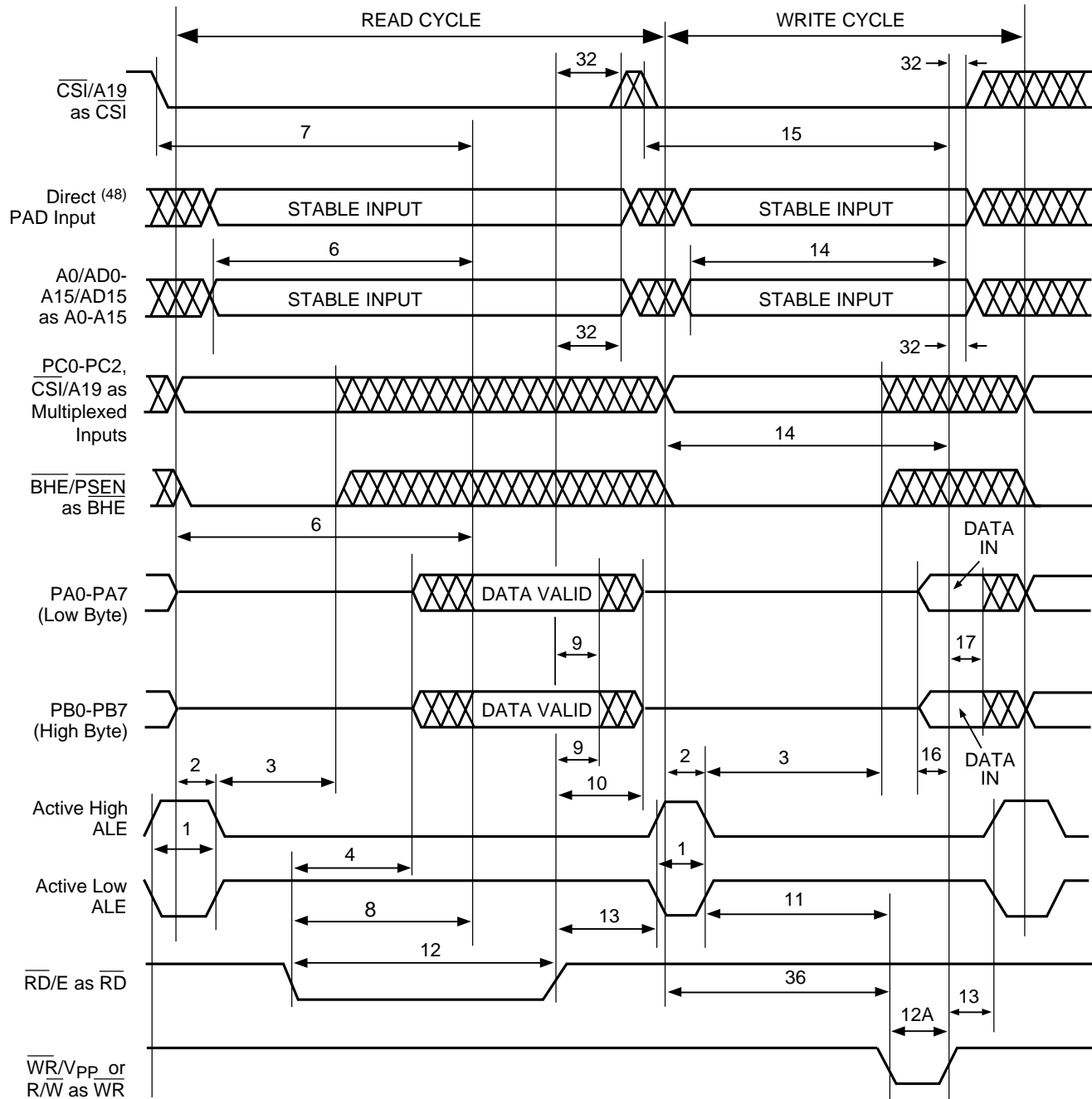
Figure 29.
Timing of 8-Bit
Non-Multiplexed
Address/Data Bus,
CRRWR = 1
(PSD3X2/3X3/3X4R)



See referenced notes on page 2-61.



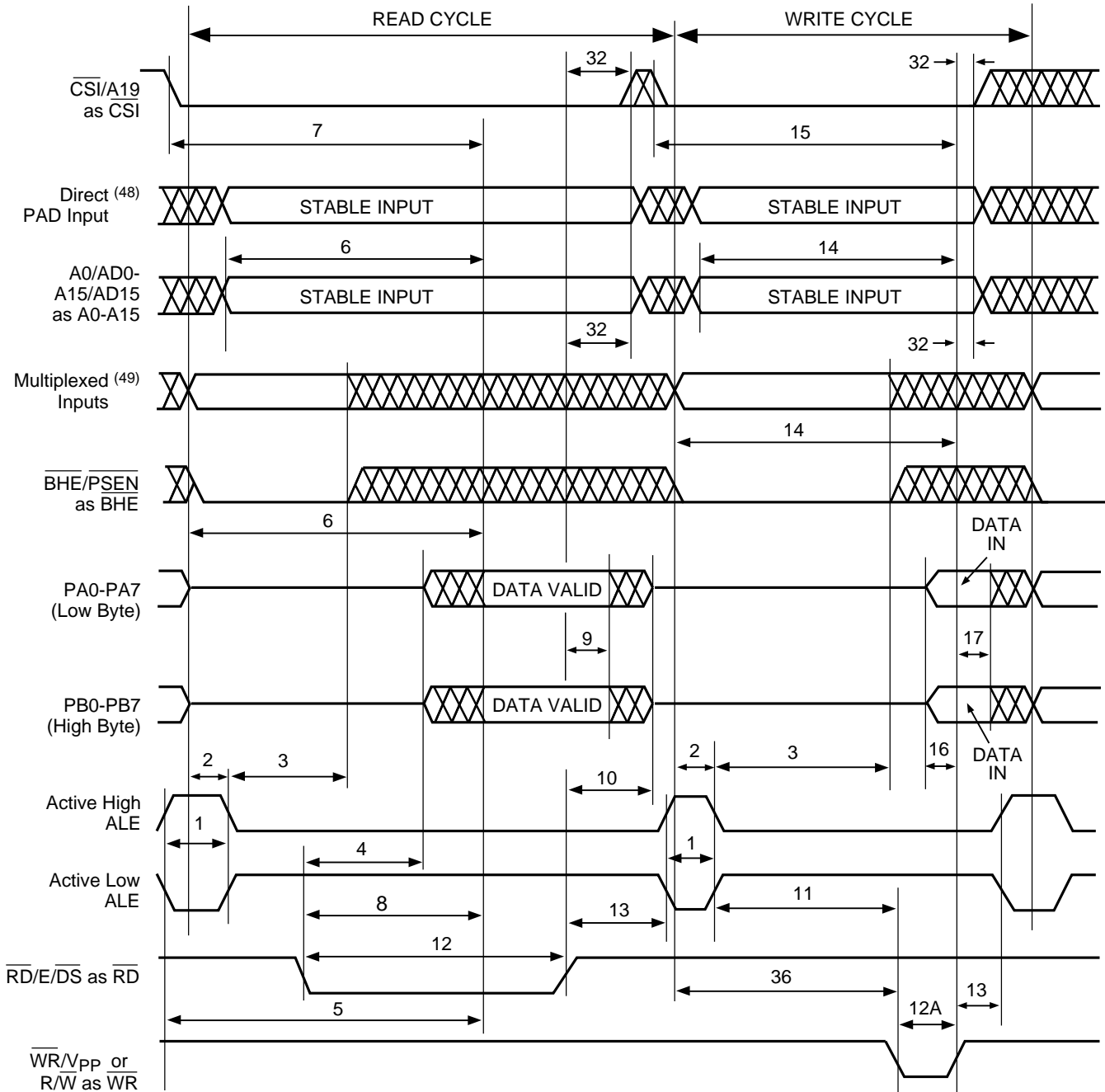
Figure 30.
Timing of 16-Bit
Non-Multiplexed
Address/Data
Bus, CRRWR = 0
(PSD3X1)



See referenced notes on page 2-61.



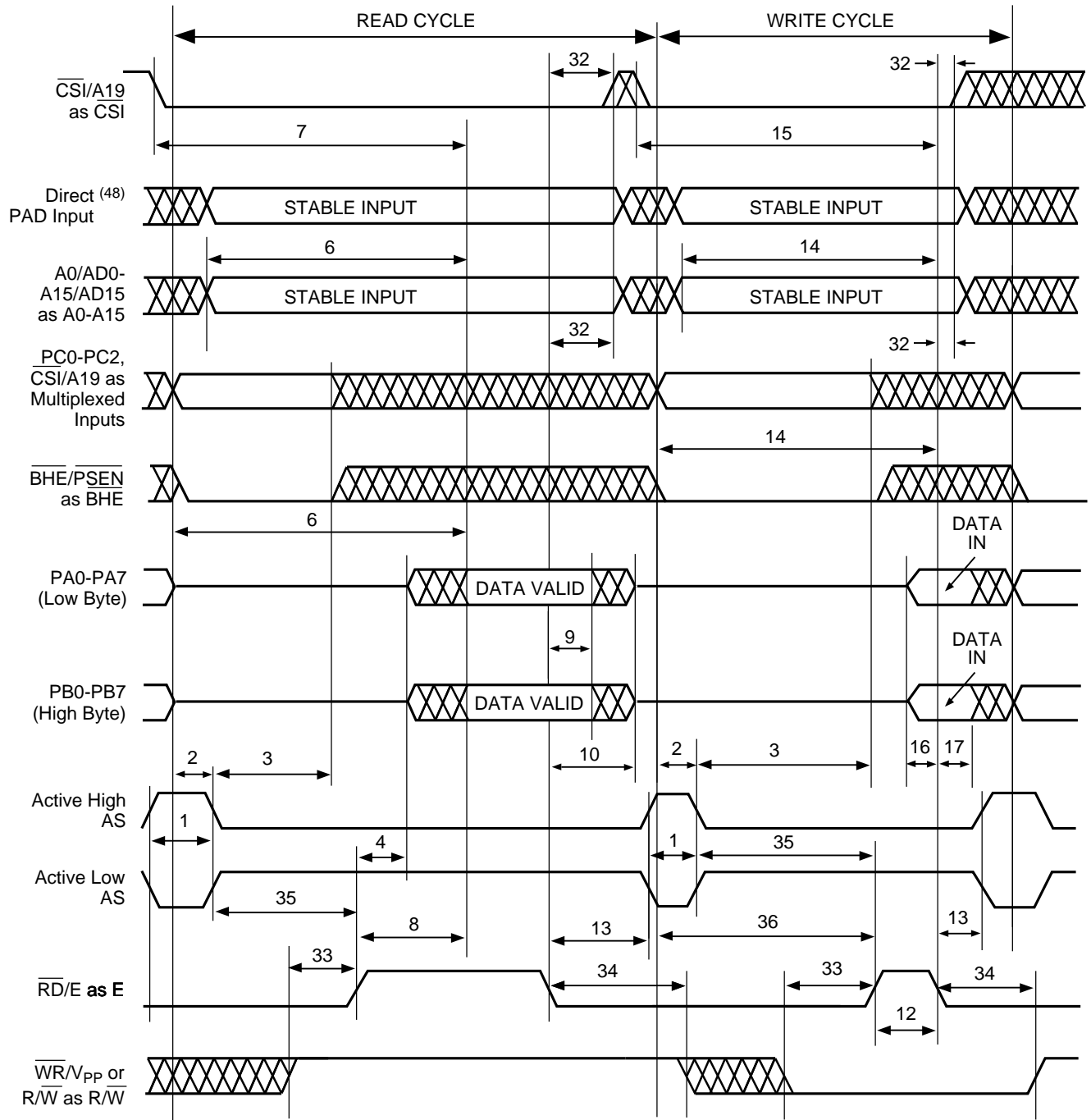
Figure 31.
Timing of 16-Bit
Non-Multiplexed
Address/Data Bus,
CRRWR = 0
(PSD3X2/3X3/3X4R)



See referenced notes on page 2-61.



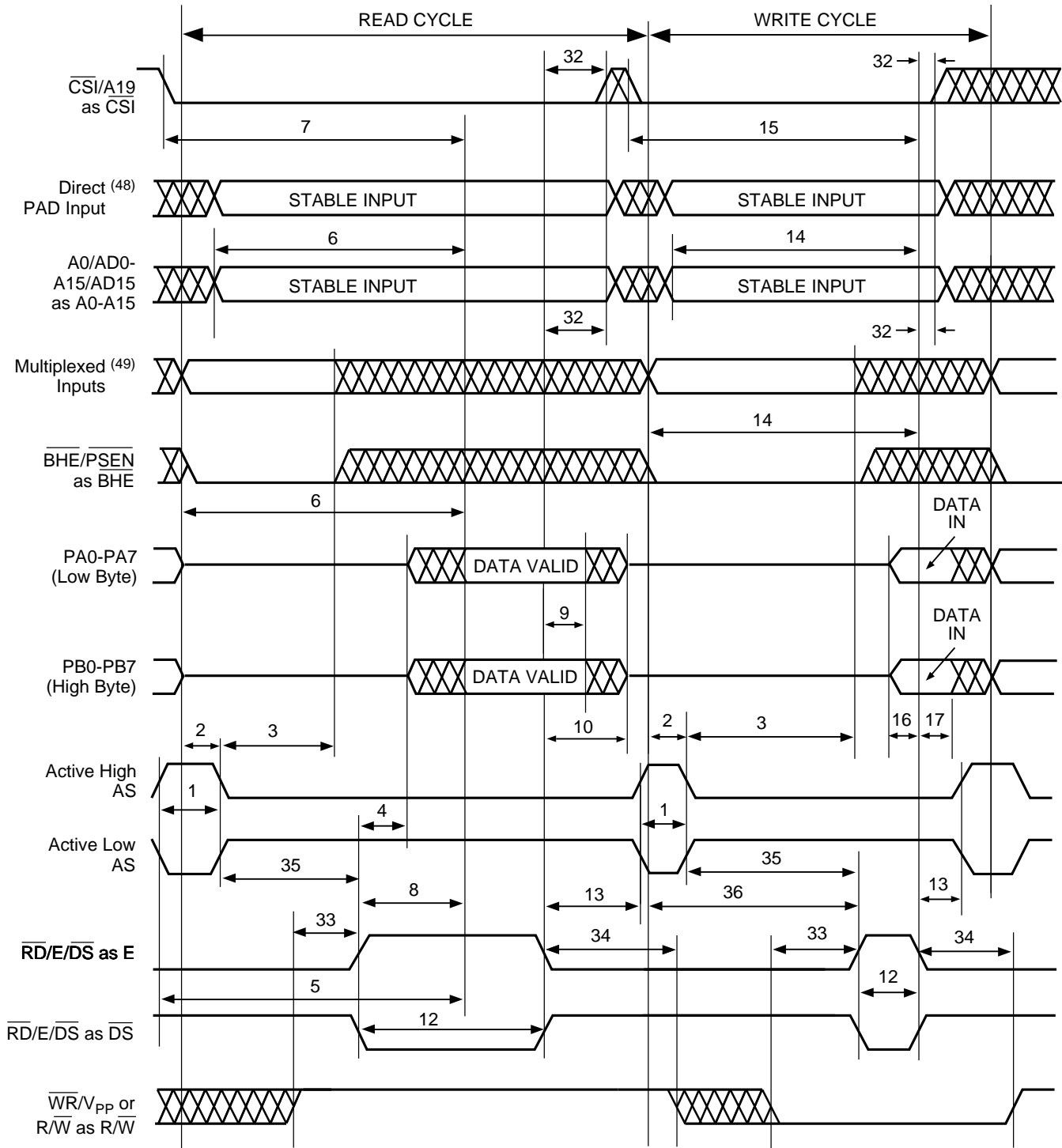
Figure 32.
Timing of 16-Bit
Non-Multiplexed
Address/Data
Bus, CRRWR = 1
(PSD3X1)



See referenced notes on page 2-61.



Figure 33.
Timing of 16-Bit
Non-Multiplexed
Address/Data
Bus, CRRWR = 1
(PSD3X2/3X3/3X4R)



See referenced notes on page 2-61.



Figure 34.
Chip-Select
Output Timing
(PSD30X)

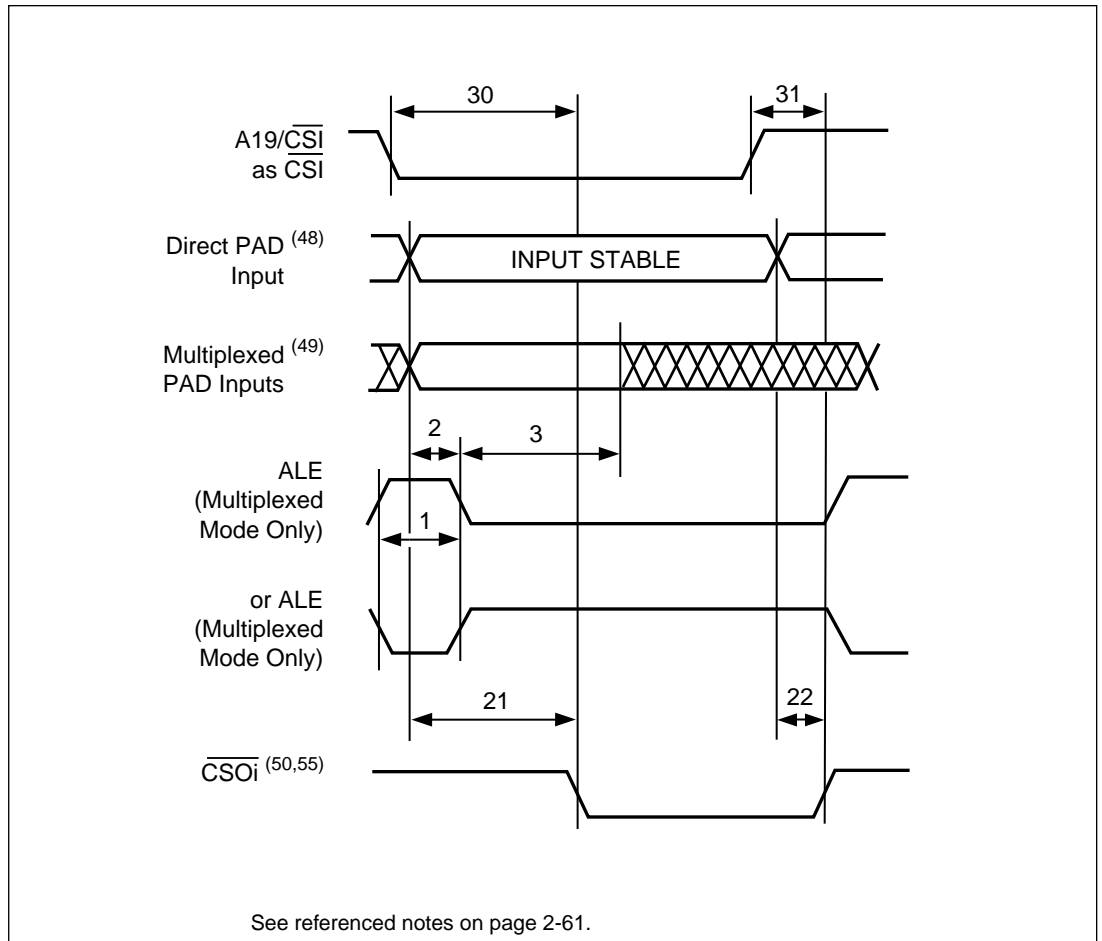
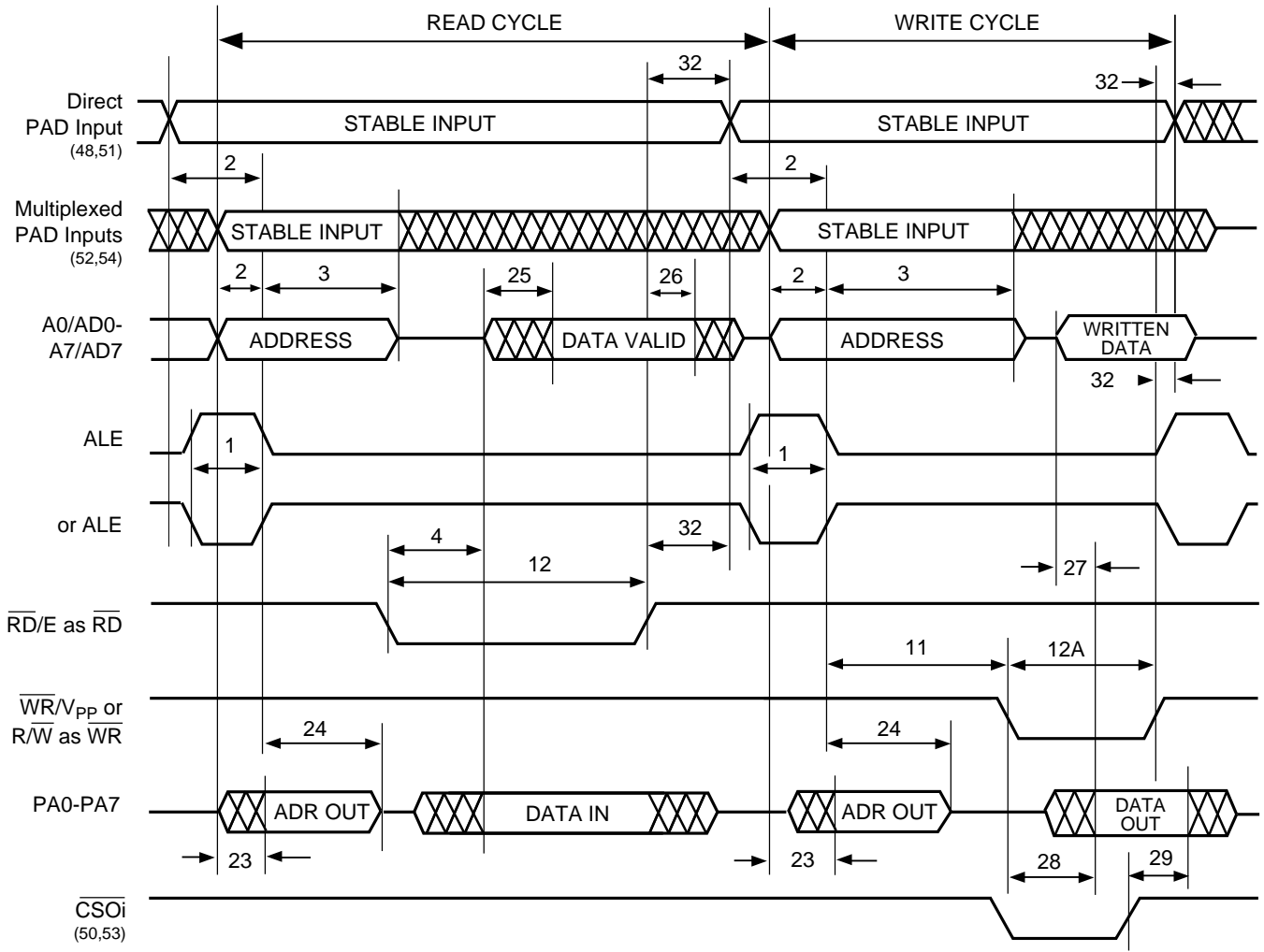


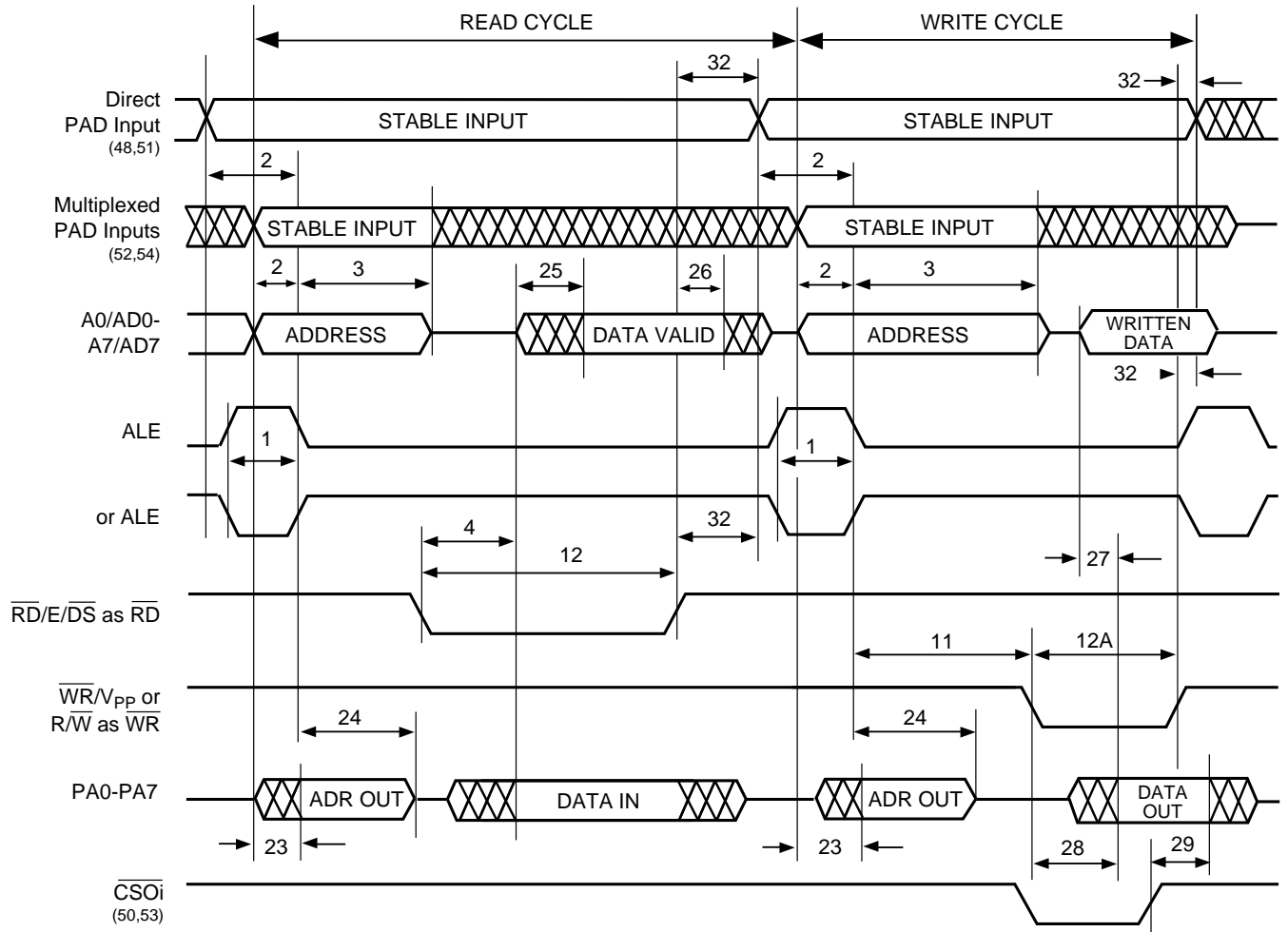
Figure 35.
Port A as
AD0-AD7 Timing
(Track Mode),
CRRWR = 0
(PSD3X1)



See referenced notes on page 2-61.

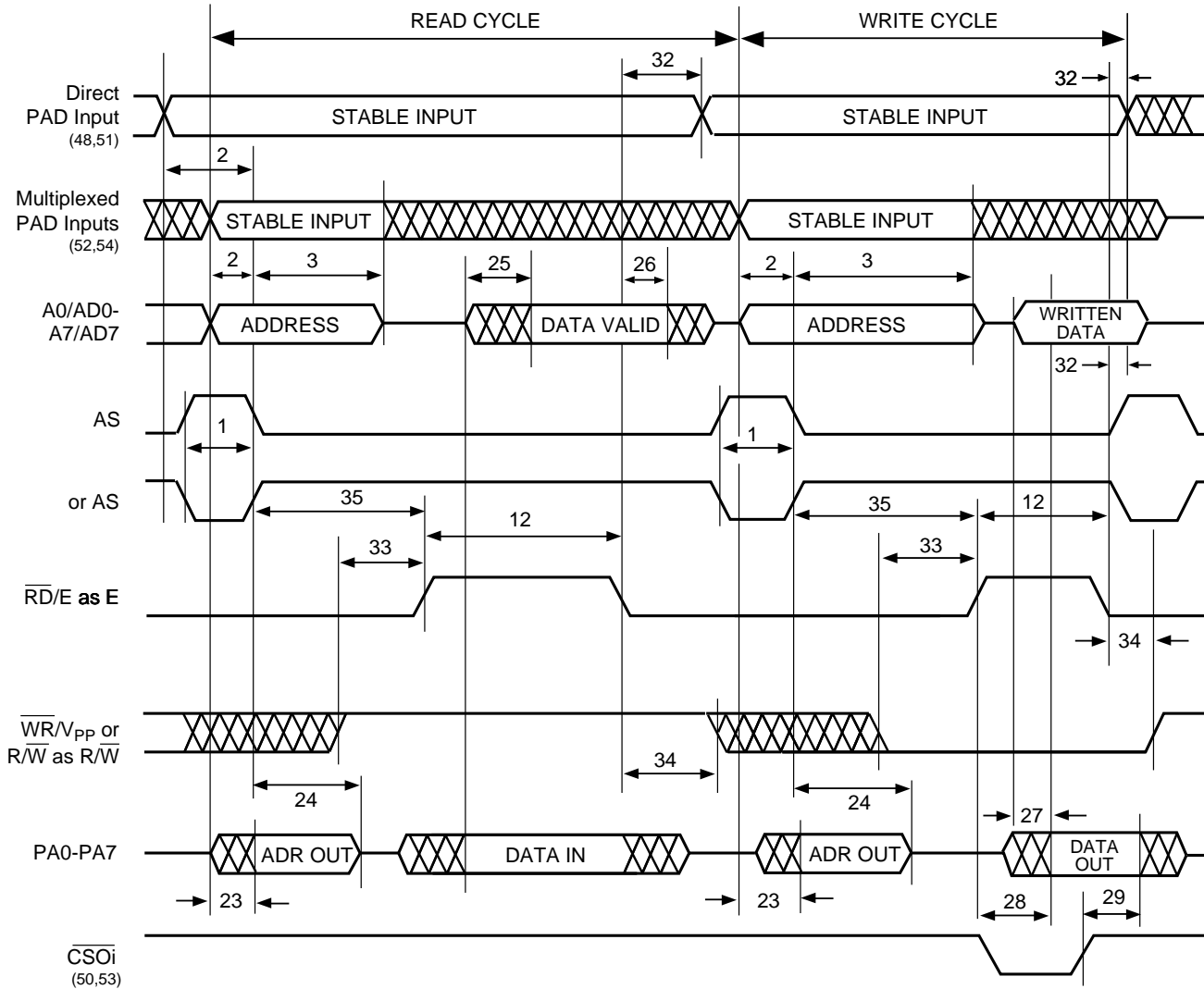


Figure 36.
Port A as
AD0-AD7 Timing
(Track Mode),
CRRWR = 0
(PSD3X2/3X3/3X4R)



See referenced notes on page 2-61.

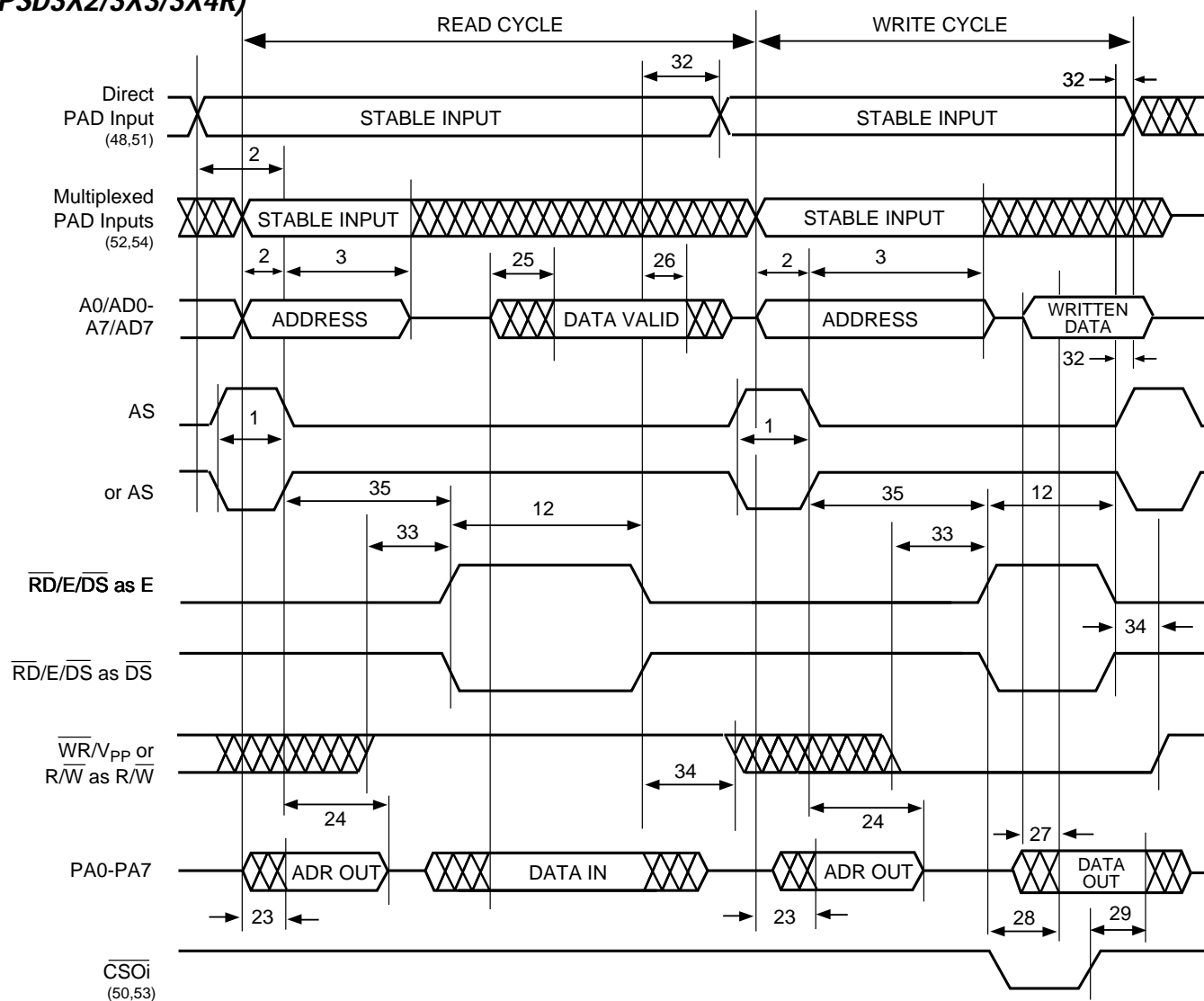
Figure 37.
Port A as
AD0-AD7 Timing
(Track Mode),
CRRWR = 1
(PSD3X1)



See referenced notes on page 2-61.



Figure 38.
Port A as
AD0–AD7 Timing
(Track Mode),
CRRWR = 1
(PSD3X2/3X3/3X4R)



Notes for Timing Diagrams

48. Direct PAD input = any of the following direct PAD input lines: $\overline{CSi}/A19$ as transparent A19, $\overline{RD}/E/\overline{DS}$, \overline{WR} or R/\overline{W} , transparent PC0–PC2, ALE in non-multiplexed modes.
49. Multiplexed inputs: any of the following inputs that are latched by the ALE (or AS): A0/AD0–A15/AD15, $\overline{CSi}/A19$ as ALE dependent A19, ALE dependent PC0–PC2.
50. $\overline{CS0i}$ = any of the chip-select output signals coming through Port B ($\overline{CS0}$ – $\overline{CS7}$) or through Port C ($\overline{CS8}$ – $\overline{CS10}$).
51. CSADOUT1, which internally enables the address transfer to Port A, should be derived only from direct PAD input signals, otherwise the address propagation delay is slowed down.
52. CSADIN and CSADOUT2, which internally enable the data-in or data-out transfers, respectively, can be derived from any combination of direct PAD inputs and multiplexed PAD inputs.
53. The write operation signals are included in the $\overline{CS0i}$ expression.
54. Multiplexed PAD inputs: any of the following PAD inputs that are latched by the ALE (or AS) in the multiplexed modes: A11/AD11–A15/AD15, $\overline{CSi}/A19$ as ALE dependent A19, ALE dependent PC0–PC2.
55. $\overline{CS0i}$ product terms can include any of the PAD input signals shown in Figure 3, except for reset and \overline{CSi} .

Table 14.
Pin
Capacitance⁵⁶

Symbol	Parameter	Conditions	Typical ⁵⁷	Max	Unit
C _{IN}	Capacitance (for input pins only)	V _{IN} = 0 V	4	6	pF
C _{OUT}	Capacitance (for input/output pins)	V _{OUT} = 0 V	8	12	pF
C _{VPP}	Capacitance (for WR/V _{PP} or R/W/V _{PP})	V _{PP} = 0 V	18	25	pF

NOTES: 56. This parameter is only sampled and is not 100% tested.
57. Typical values are for T_A = 25°C and nominal supply voltages.

Figure 39.
AC Testing
Input/Output
Waveform
(PSD3XX
Versions)

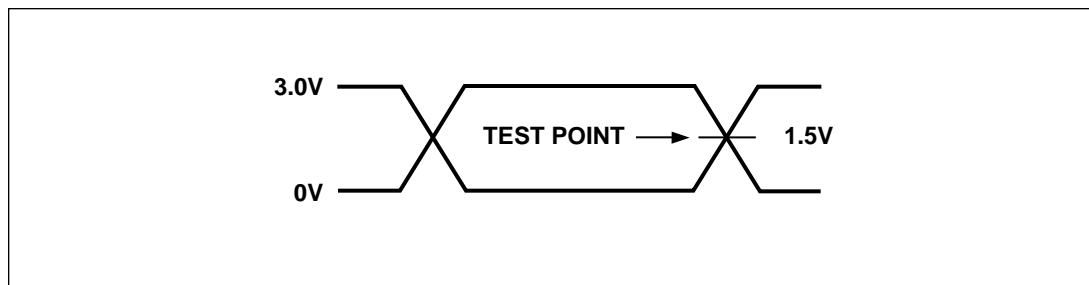


Figure 39a.
AC Testing
Input/Output
Waveform
(PSD3XXL
Versions)

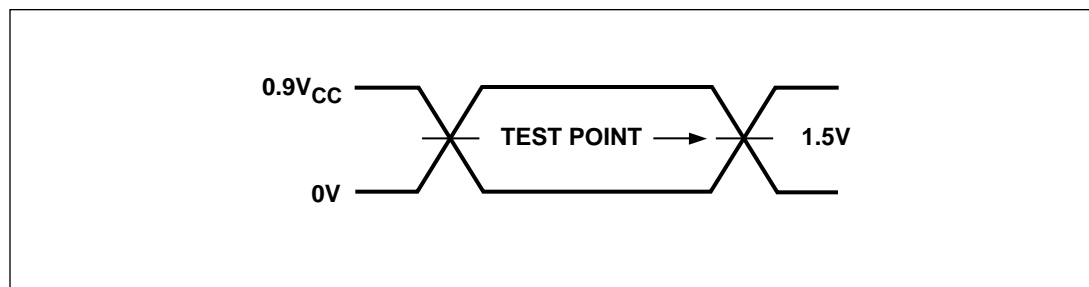


Figure 40.
AC Testing
Load Circuit
(PSD3XX
Versions)

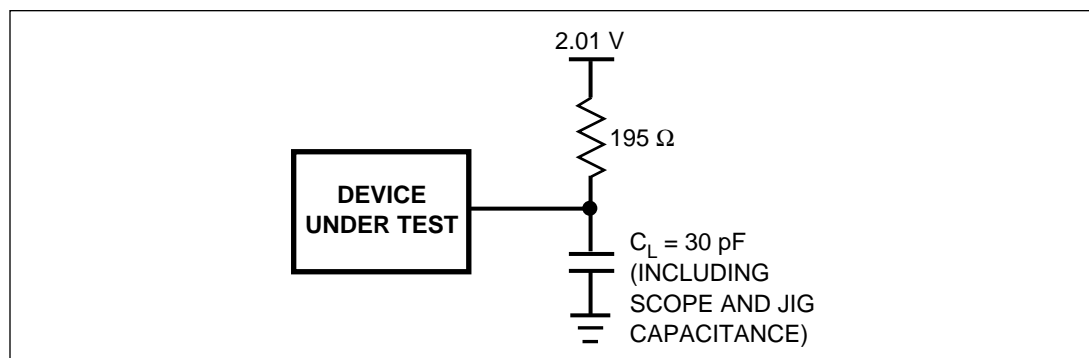
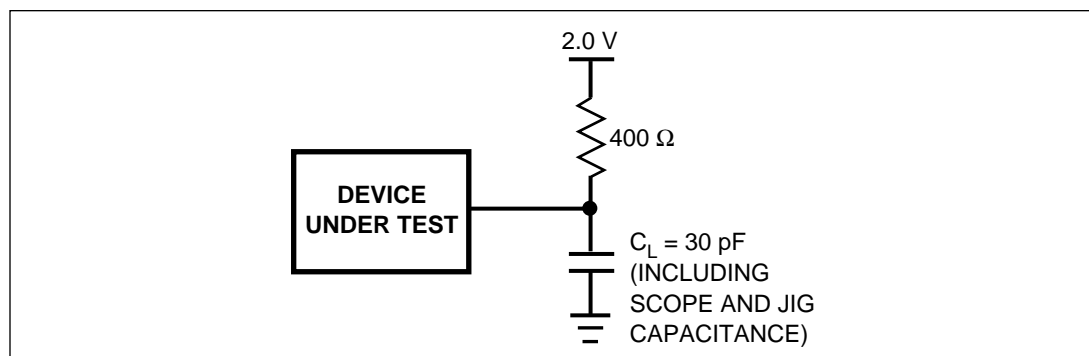


Figure 40a.
AC Testing
Load Circuit
(PSD3XXL
Versions)



**Erase and
Programming**

To clear all locations of their programmed contents, expose the window packaged device to an ultra-violet light source. A dosage of 30 W second/cm² is required (40 W second/cm² for PSD3XXL versions). This dosage can be obtained with exposure to a wavelength of 2537 Å and intensity of 12000 μW/cm² for 40 to 45 minutes (50 to 60 minutes for PSD3XXL versions). The device should be about 1 inch from the source, and all filters should be removed from the UV light source prior to erasure.

The PSD3XX and similar devices will erase with light sources having wavelengths shorter than 4000 Å. Although the erasure times will be much longer than with UV sources at 2537 Å, exposure to fluorescent light and sunlight eventually erases the device. For maximum system reliability, these sources should be avoided. If used in such an environment, the package window should be covered by an opaque substance. Upon delivery from WSI, or after each erasure, the PSD3XX device has all bits in the PAD and EPROM in the "1" or high state. The configuration bits are in the "0" or low state. The code, configuration, and PAD MAP data are loaded through the procedure of programming

Information for programming the device is available directly from WSI. Please contact your local sales representative.



Programmable Peripheral PSD301 Field-Programmable Microcontroller Peripheral

Key Features

- Single Chip Programmable Peripheral for Microcontroller-based Applications
- 19 Individually Configurable I/O pins that can be used as:
 - Microcontroller I/O port expansion
 - Programmable Address Decoder (PAD) I/O
 - Latched address output
 - Open drain or CMOS
- Two Programmable Arrays (PAD A and PAD B)
 - Total of 40 Product Terms and up to 12 Inputs and 24 Outputs
 - Address Decoding up to 1 MB
 - Logic replacement
- “No Glue” Microcontroller Chip-Set
 - Built-in address latches for multiplexed address/data bus
 - Non-multiplexed address/data bus mode
 - Selectable 8 or 16 bit data bus width
 - ALE and Reset polarity programmable
 - Selectable modes for read and write control bus as $\overline{RD}/\overline{WR}$ or $R/\overline{W}/E$
 - \overline{BHE} pin for byte select in 16-bit mode
 - \overline{PSEN} pin for 8051 users
- 256 Kbits of UV EPROM
 - Configurable as 32K x 8 or as 16K x 16
 - Divides into 8 equal mappable blocks for optimized mapping
 - Block resolution is 4K x 8 or 2K x 16
 - 70 ns EPROM access time, including input latches and PAD address decoding.
- 16 Kbit Static RAM
 - Configurable as 2K x 8 or as 1K x 16
 - 70 ns SRAM access time, including input latches and PAD address decoding
- Address/Data Track Mode
 - Enables easy Interface to Shared Resources (e.g., Mail Box SRAM) with other Microcontrollers or a Host Processor
- Built-In Security
 - Locks the PSD301 and PAD Decoding Configuration
- Available in a Choice of Packages
 - 44 Pin PLDCC, CLDCC and TQFP
 - 52 Pin PQFP
 - 44 Pin CPGA
- Simple Menu-Driven Software:
 - Configure the PSD301 on an IBM PC
- Pin and Function Compatible with the PSD302/302L, PSD303/303L and PSD304R/314RL

**PSD301
Pin
Assignments**

<i>Pin Name</i>	<i>44-Pin PLDCC/CLDCC Package</i>	<i>44-Pin CPGA Package</i>	<i>44-Pin TQFP Package</i>	<i>52-Pin PQFP Package (Note 58)</i>
$\overline{\text{BHE}}/\overline{\text{PSEN}}$	1	A ₅	39	46
$\overline{\text{WR}}/\text{V}_{\text{PP}}$ or $\text{R}/\overline{\text{W}}$	2	A ₄	40	47
RESET	3	B ₄	41	48
PB7	4	A ₃	42	49
PB6	5	B ₃	43	50
PB5	6	A ₂	44	51
PB4	7	B ₂	1	2
PB3	8	B ₁	2	3
PB2	9	C ₂	3	4
PB1	10	C ₁	4	5
PB0	11	D ₂	5	6
GND	12	D ₁	6	7
ALE or AS	13	E ₁	7	8
PA7	14	E ₂	8	9
PA6	15	F ₁	9	10
PA5	16	F ₂	10	11
PA4	17	G ₁	11	12
PA3	18	G ₂	12	15
PA2	19	H ₂	13	16
PA1	20	G ₃	14	17
PA0	21	H ₃	15	18
$\overline{\text{RD}}/\text{E}$	22	G ₄	16	19
AD0/A0	23	H ₄	17	20
AD1/A1	24	H ₅	18	21
AD2/A2	25	G ₅	19	22
AD3/A3	26	H ₆	20	23
AD4/A4	27	G ₆	21	24
AD5/A5	28	H ₇	22	25
AD6/A6	29	G ₇	23	28
AD7/A7	30	G ₈	24	29
AD8/A8	31	F ₇	25	30
AD9/A9	32	F ₈	26	31
AD10/A10	33	E ₇	27	32
GND	34	E ₈	28	33
AD11/A11	35	D ₈	29	34
AD12/A12	36	D ₇	30	35
AD13/A13	37	C ₈	31	36
AD14/A14	38	C ₇	32	37
AD15/A15	39	B ₈	33	38
PC0	40	B ₇	34	41
PC1	41	A ₇	35	42
PC2	42	B ₆	36	43
A19/ $\overline{\text{CSI}}$	43	A ₆	37	44
V _{CC}	44	B ₅	38	45

NOTE: 58. Pins 1, 13, 14, 26, 27, 39, 40, and 52 are No Connect.

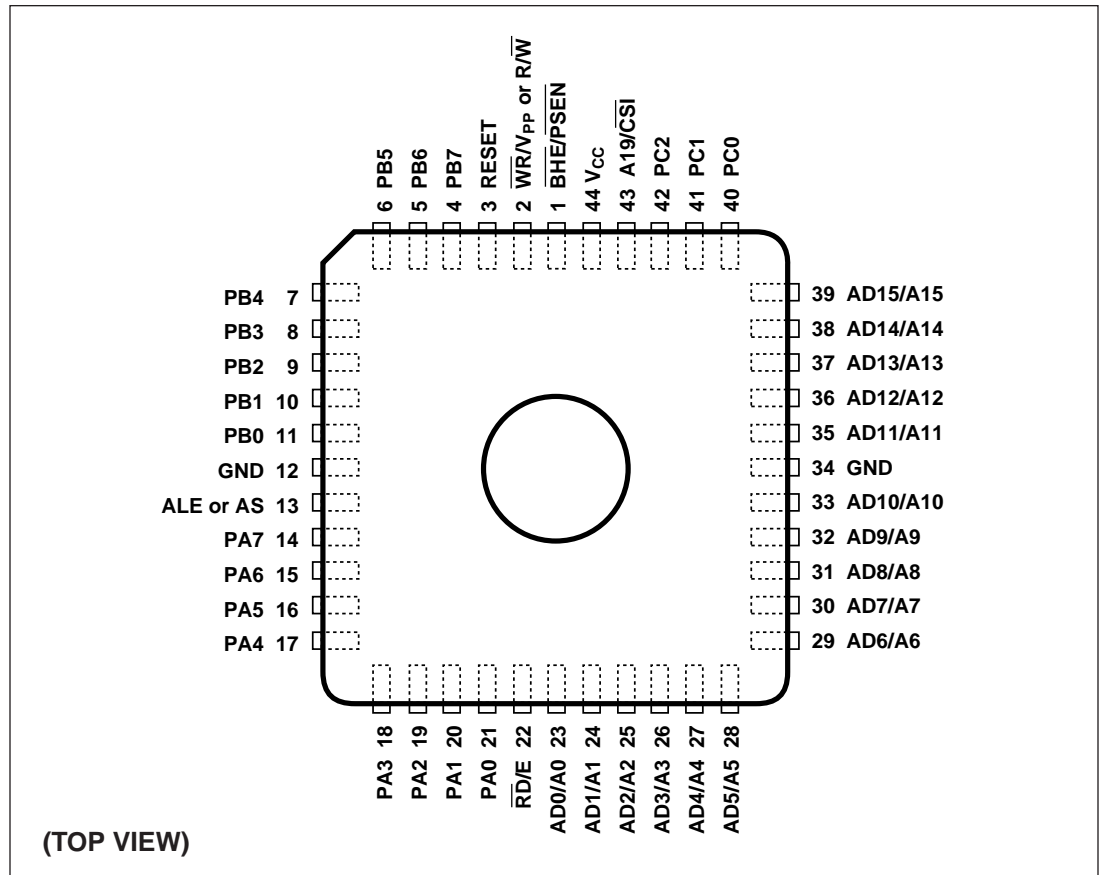


**PSD301
Package
Information**

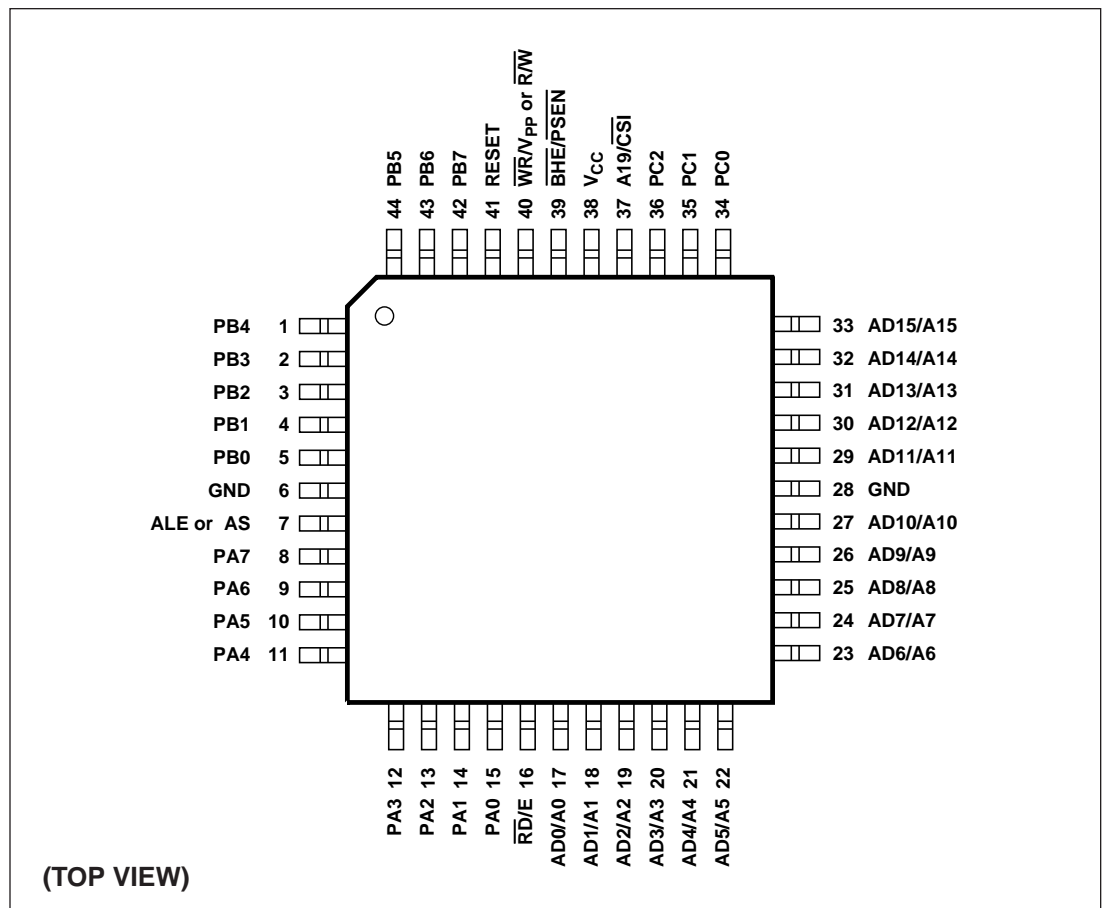
**Figure 41.
Drawing L4 –
44 Pin Ceramic
Leaded Chip
Carrier (CLDCC)
with Window
(Package Type L)**

OR

**Drawing J2 –
44 Pin Plastic
Leaded Chip
Carrier (PLDCC)
without Window
(Package Type J)**

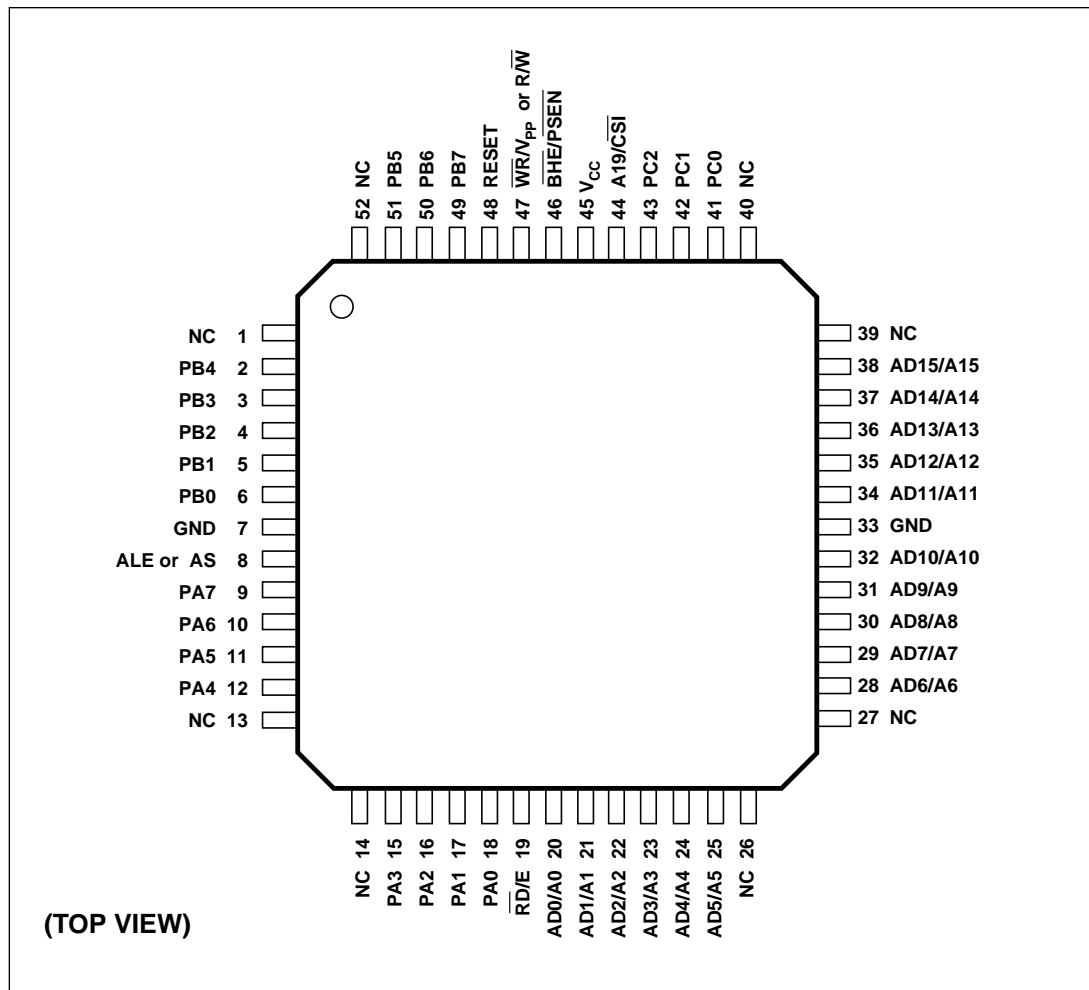


**Figure 42.
Drawing U1 –
44 Pin Plastic
Thin Quad
Flatpack (TQFP)
(Package Type U)**

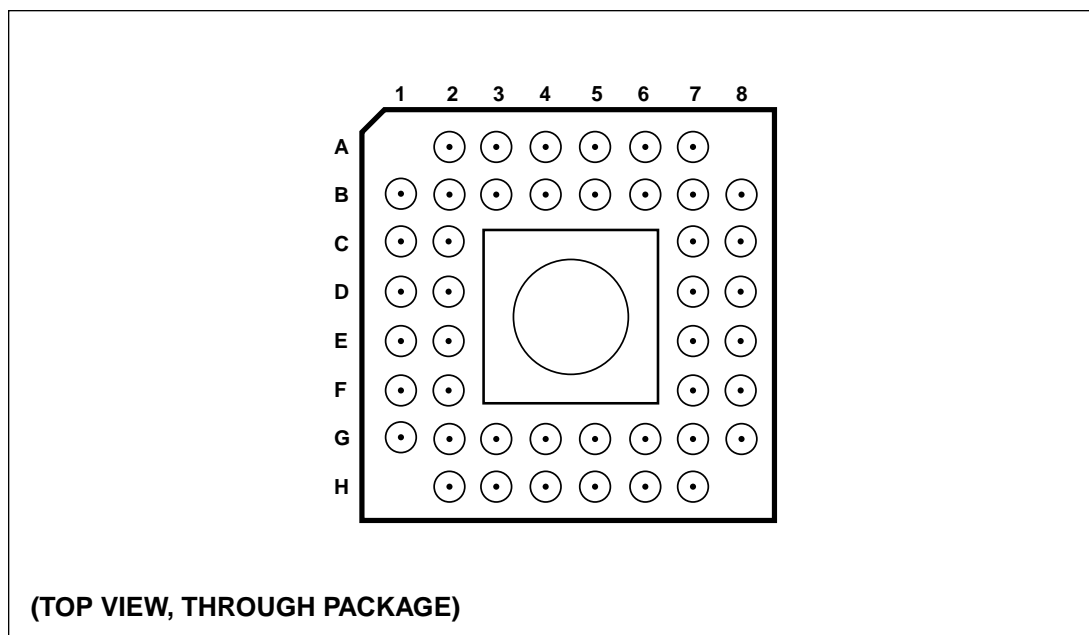


**PSD301
Package
Information**

**Figure 43.
Drawing Q2 –
52 Pin PQFP
(Package Type Q)**



**Figure 44.
Drawing X2 –
44 Pin CPGA
(Package Type X)**





Programmable Peripheral PSD311 Field-Programmable Microcontroller Peripheral

Key Features

- Single Chip Programmable Peripheral for Microcontroller-based Applications
- 19 Individually Configurable I/O pins that can be used as:
 - Microcontroller I/O port expansion
 - Programmable Address Decoder (PAD) I/O
 - Latched address output
 - Open drain or CMOS
- Two Programmable Arrays (PAD A and PAD B)
 - Total of 40 Product Terms and up to 12 Inputs and 24 Outputs
 - Address Decoding up to 1 MB
 - Logic replacement
- “No Glue” Microcontroller Chip-Set
 - Built-in address latches for multiplexed address/data bus
 - Non-multiplexed address/data bus mode
 - 8-bit data bus width
 - ALE and Reset polarity programmable
 - Selectable modes for read and write control bus as $\overline{RD}/\overline{WR}$ or $R/\overline{W}/E$
 - \overline{PSEN} pin for 8051 users
- 256 Kbits of UV EPROM
 - Configurable as 32K x 8
 - Divides into 8 equal mappable blocks for optimized mapping
 - Block resolution is 4K x 8
 - 70 ns EPROM access time, including input latches and PAD address decoding.
- 16 Kbit Static RAM
 - Configurable as 2K x 8
 - 70 ns SRAM access time, including input latches and PAD address decoding
- Address/Data Track Mode
 - Enables easy Interface to Shared Resources (e.g., Mail Box SRAM) with other Microcontrollers or a Host Processor
- Built-In Security
 - Locks the PSD311 and PAD Decoding Configuration
- Available in a Choice of Packages
 - 44 Pin PLDCC, CLDCC and TQFP
 - 52 Pin PQFP
- Simple Menu-Driven Software:
 - Configure the PSD311 on an IBM PC
- Pin and Function Compatible with the PSD312/312L, PSD313/313L and PSD314R/314RL

**PSD311
Pin
Assignments**

<i>Pin Name</i>	<i>44-Pin PLDCC/CLDCC Package</i>	<i>44-Pin TQFP Package</i>	<i>52-Pin PQFP Package (Note 59)</i>
$\overline{\text{PSEN}}$	1	39	46
$\overline{\text{WR}}/\text{V}_{\text{PP}}$ or $\text{R}/\overline{\text{W}}$	2	40	47
RESET	3	41	48
PB7	4	42	49
PB6	5	43	50
PB5	6	44	51
PB4	7	1	2
PB3	8	2	3
PB2	9	3	4
PB1	10	4	5
PB0	11	5	6
GND	12	6	7
ALE or AS	13	7	8
PA7	14	8	9
PA6	15	9	10
PA5	16	10	11
PA4	17	11	12
PA3	18	12	15
PA2	19	13	16
PA1	20	14	17
PA0	21	15	18
$\overline{\text{RD}}/\text{E}$	22	16	19
AD0/A0	23	17	20
AD1/A1	24	18	21
AD2/A2	25	19	22
AD3/A3	26	20	23
AD4/A4	27	21	24
AD5/A5	28	22	25
AD6/A6	29	23	28
AD7/A7	30	24	29
A8	31	25	30
A9	32	26	31
A10	33	27	32
GND	34	28	33
A11	35	29	34
A12	36	30	35
A13	37	31	36
A14	38	32	37
A15	39	33	38
PC0	40	34	41
PC1	41	35	42
PC2	42	36	43
A19/ $\overline{\text{CSI}}$	43	37	44
V _{CC}	44	38	45

NOTE: 59. Pins 1, 13, 14, 26, 27, 39, 40, and 52 are No Connect.

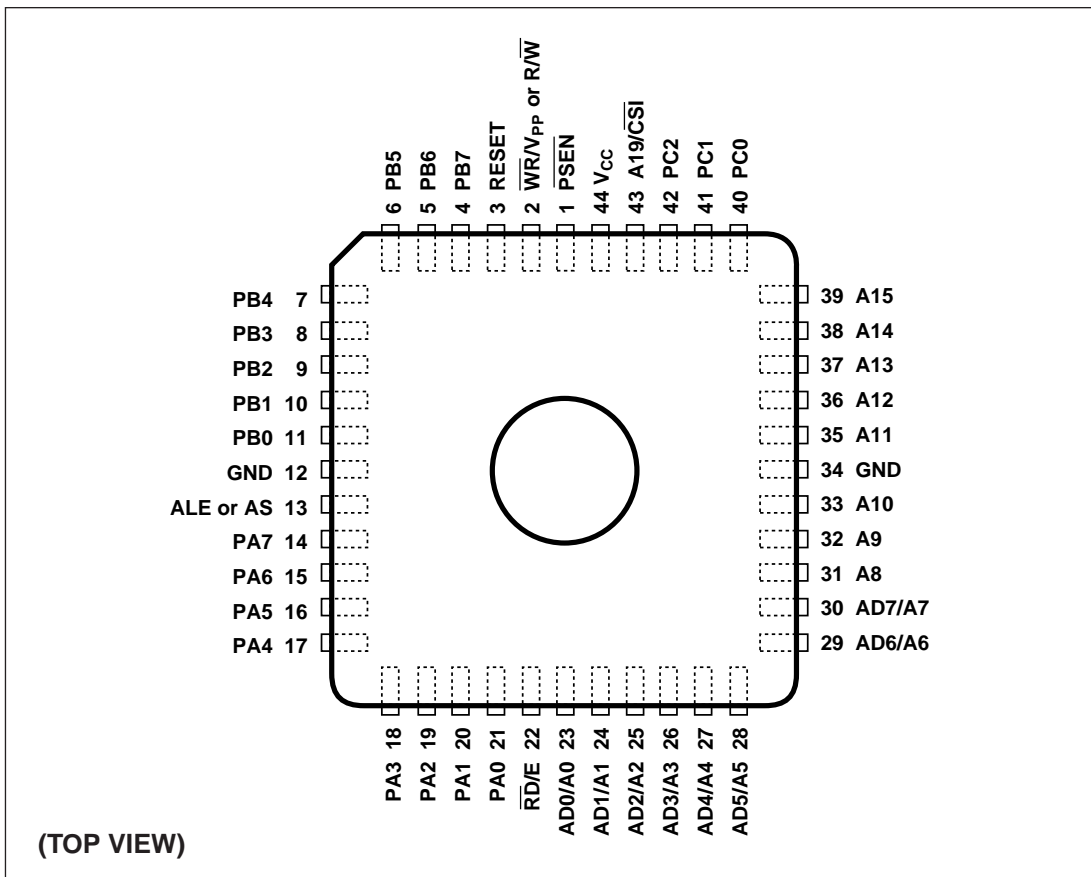


**PSD311
Package
Information**

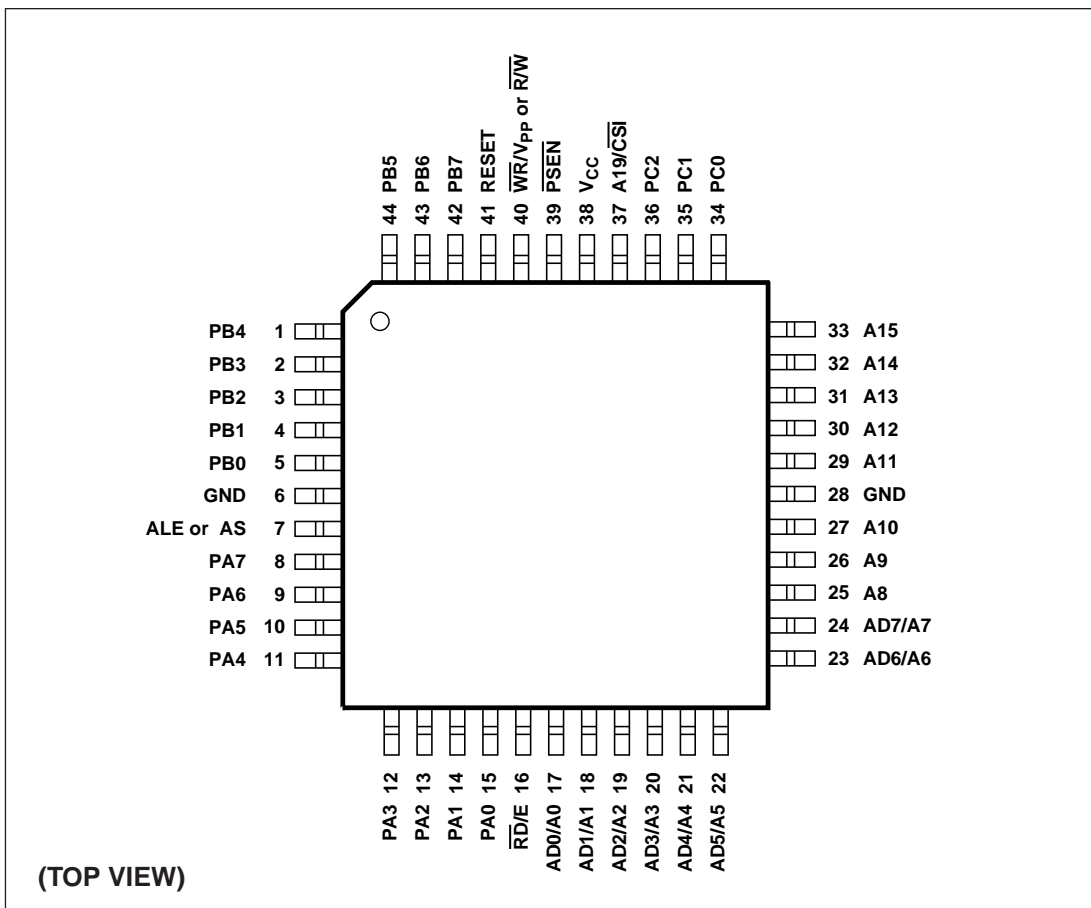
**Figure 45.
Drawing L4 –
44 Pin Ceramic
Leaded Chip
Carrier (CLDCC)
with Window
(Package Type L)**

OR

**Drawing J2 –
44 Pin Plastic
Leaded Chip
Carrier (PLDCC)
without Window
(Package Type J)**

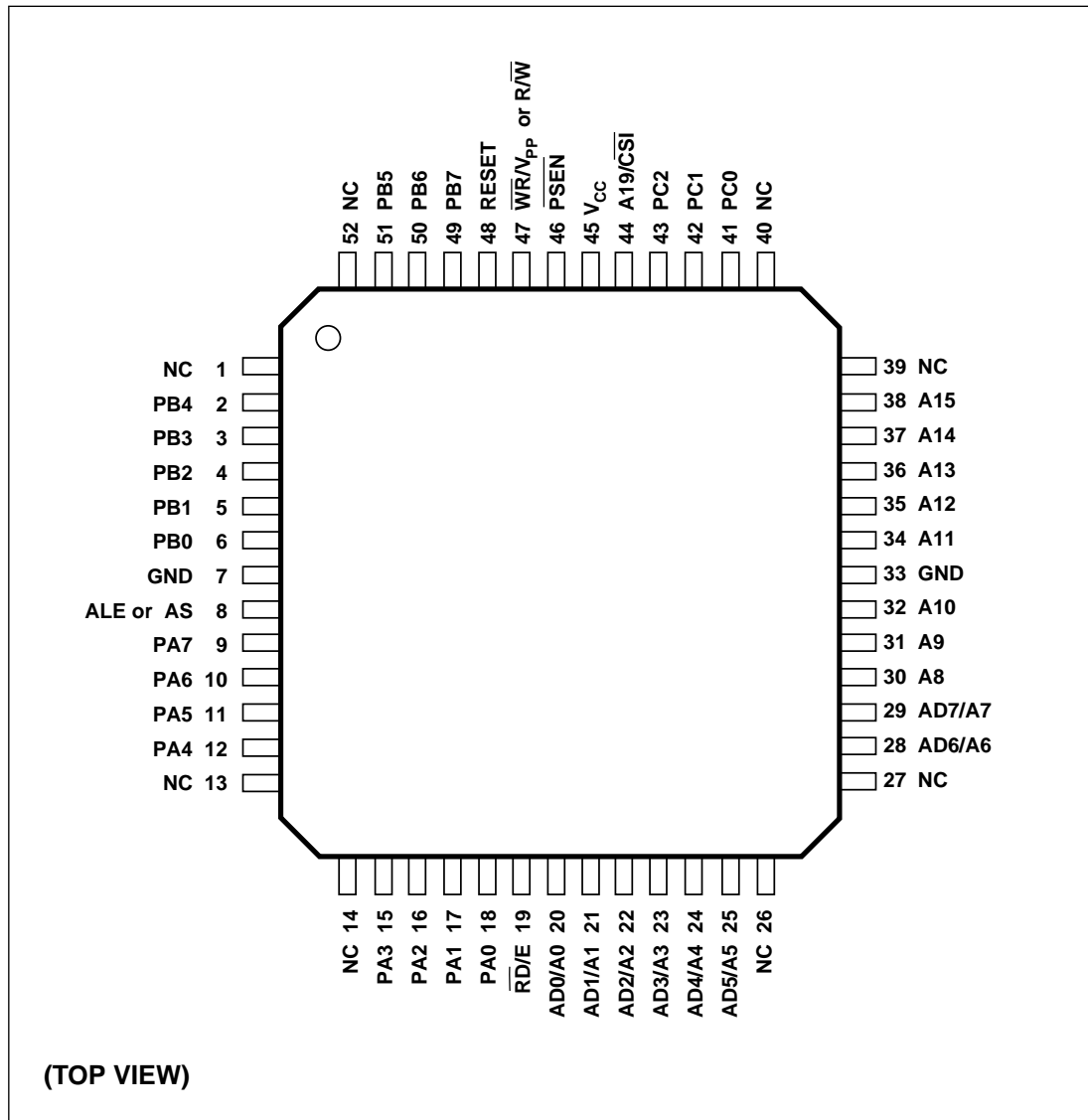


**Figure 46.
Drawing U1 –
44 Pin Plastic
Thin Quad
Flatpack (TQFP)
(Package Type U)**



**PSD311
Package
Information**

**Figure 47.
Drawing Q2 –
52 Pin PQFP
(Package Type Q)**





Programmable Peripheral PSD302 Field-Programmable Microcontroller Peripheral

Key Features

- Single Chip Programmable Peripheral for Microcontroller-based Applications
- 19 Individually Configurable I/O pins that can be used as:
 - Microcontroller I/O port expansion
 - Programmable Address Decoder (PAD) I/O
 - Latched address output
 - Open drain or CMOS
- Two Programmable Arrays (PAD A & PAD B)
 - Total of 40 Product Terms and up to 16 Inputs and 24 Outputs
 - Direct Address Decoding up to 1 Meg address space and up to 16 Meg with paging
 - Logic replacement
- “No Glue” Microcontroller Chip-Set
 - Built-in address latches for multiplexed address/data bus
 - Non-multiplexed address/data bus mode
 - Selectable 8 or 16 bit data bus width
 - ALE and Reset polarity programmable
 - Selectable modes for read and write control bus as $\overline{RD}/\overline{WR}$, $R/\overline{W}/E$, or $R/\overline{W}/\overline{DS}$
 - \overline{BHE} pin for byte select in 16-bit mode
 - \overline{PSEN} pin for 8051 users
- Built-In Page Logic
 - To Expand the Address Space of Microcontrollers with Limited Address Space Capabilities
 - Up to 16 pages
- 512 Kbits of UV EPROM
 - Configurable as 64K x 8 or as 32K x 16
 - Divides into 8 equal mappable blocks for optimized mapping
 - Block resolution is 8K x 8 or 4K x 16
 - 70 ns EPROM access time, including input latches and PAD address decoding.
- 16 Kbit Static RAM
 - Configurable as 2K x 8 or as 1K x 16
 - 70 ns SRAM access time, including input latches and PAD address decoding
- Address/Data Track Mode
 - Enables easy Interface to Shared Resources (e.g., Mail Box SRAM) with other Microcontrollers or a Host Processor
- CMiser-Bit
 - Programmable option to further reduce power consumption
- Built-In Security
 - Locks the PSD302 and PAD Decoding Configuration
- Available in a Choice of Packages
 - 44 Pin PLDCC, CLDCC and TQFP
 - 52 Pin PQFP
 - 44 Pin CPGA
- Simple Menu-Driven Software: Configure the PSD302 on an IBM PC
- Pin and Function Compatible with the PSD301/301L, PSD303/303L and PSD304R/304RL

**PSD302
Pin
Assignments**

<i>Pin Name</i>	<i>44-Pin PLDCC/CLDCC Package</i>	<i>44-Pin CPGA Package</i>	<i>44-Pin TQFP Package</i>	<i>52-Pin PQFP Package (Note 60)</i>
$\overline{\text{BHE}}/\overline{\text{PSEN}}$	1	A ₅	39	46
$\overline{\text{WR}}/\text{V}_{\text{PP}}$ or $\text{R}/\overline{\text{W}}$	2	A ₄	40	47
RESET	3	B ₄	41	48
PB7	4	A ₃	42	49
PB6	5	B ₃	43	50
PB5	6	A ₂	44	51
PB4	7	B ₂	1	2
PB3	8	B ₁	2	3
PB2	9	C ₂	3	4
PB1	10	C ₁	4	5
PB0	11	D ₂	5	6
GND	12	D ₁	6	7
ALE or AS	13	E ₁	7	8
PA7	14	E ₂	8	9
PA6	15	F ₁	9	10
PA5	16	F ₂	10	11
PA4	17	G ₁	11	12
PA3	18	G ₂	12	15
PA2	19	H ₂	13	16
PA1	20	G ₃	14	17
PA0	21	H ₃	15	18
$\overline{\text{RD}}/\text{E}/\overline{\text{DS}}$	22	G ₄	16	19
AD0/A0	23	H ₄	17	20
AD1/A1	24	H ₅	18	21
AD2/A2	25	G ₅	19	22
AD3/A3	26	H ₆	20	23
AD4/A4	27	G ₆	21	24
AD5/A5	28	H ₇	22	25
AD6/A6	29	G ₇	23	28
AD7/A7	30	G ₈	24	29
AD8/A8	31	F ₇	25	30
AD9/A9	32	F ₈	26	31
AD10/A10	33	E ₇	27	32
GND	34	E ₈	28	33
AD11/A11	35	D ₈	29	34
AD12/A12	36	D ₇	30	35
AD13/A13	37	C ₈	31	36
AD14/A14	38	C ₇	32	37
AD15/A15	39	B ₈	33	38
PC0	40	B ₇	34	41
PC1	41	A ₇	35	42
PC2	42	B ₆	36	43
A19/ $\overline{\text{CSI}}$	43	A ₆	37	44
V _{CC}	44	B ₅	38	45

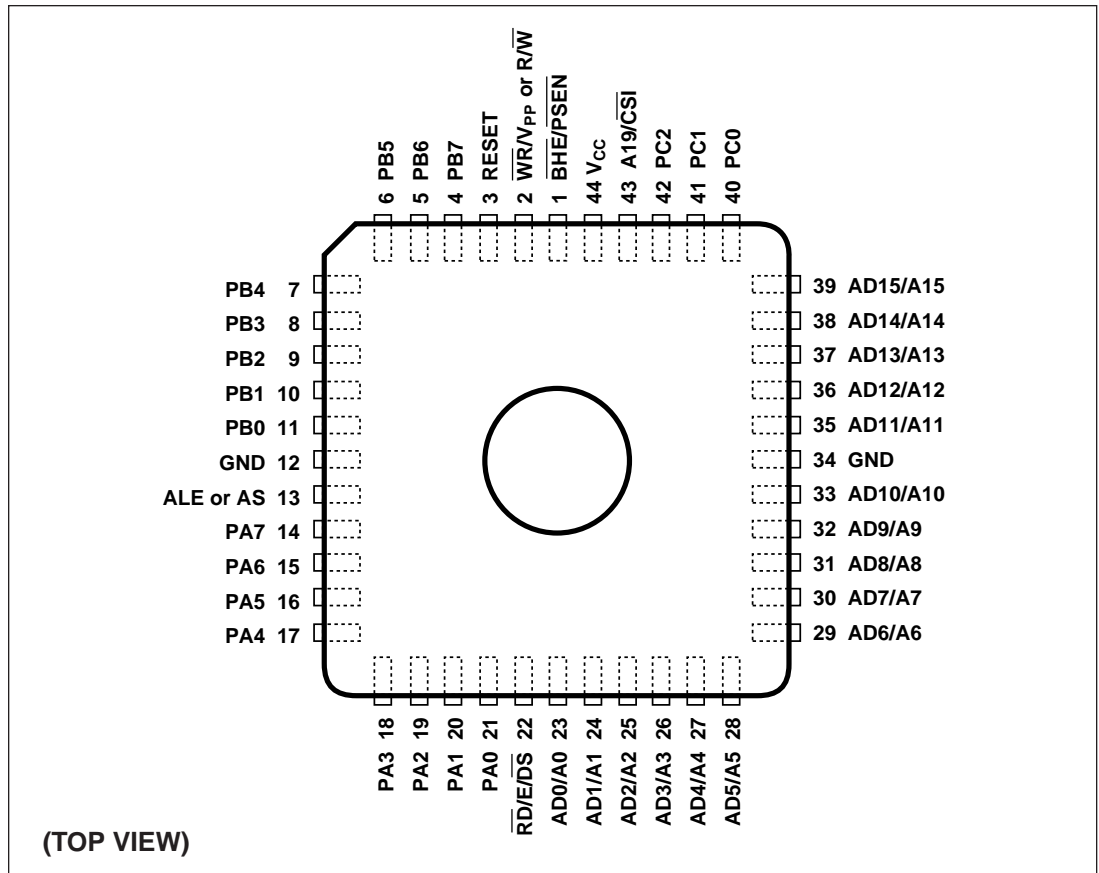
NOTE: 60. Pins 1, 13, 14, 26, 27, 39, 40, and 52 are No Connect.



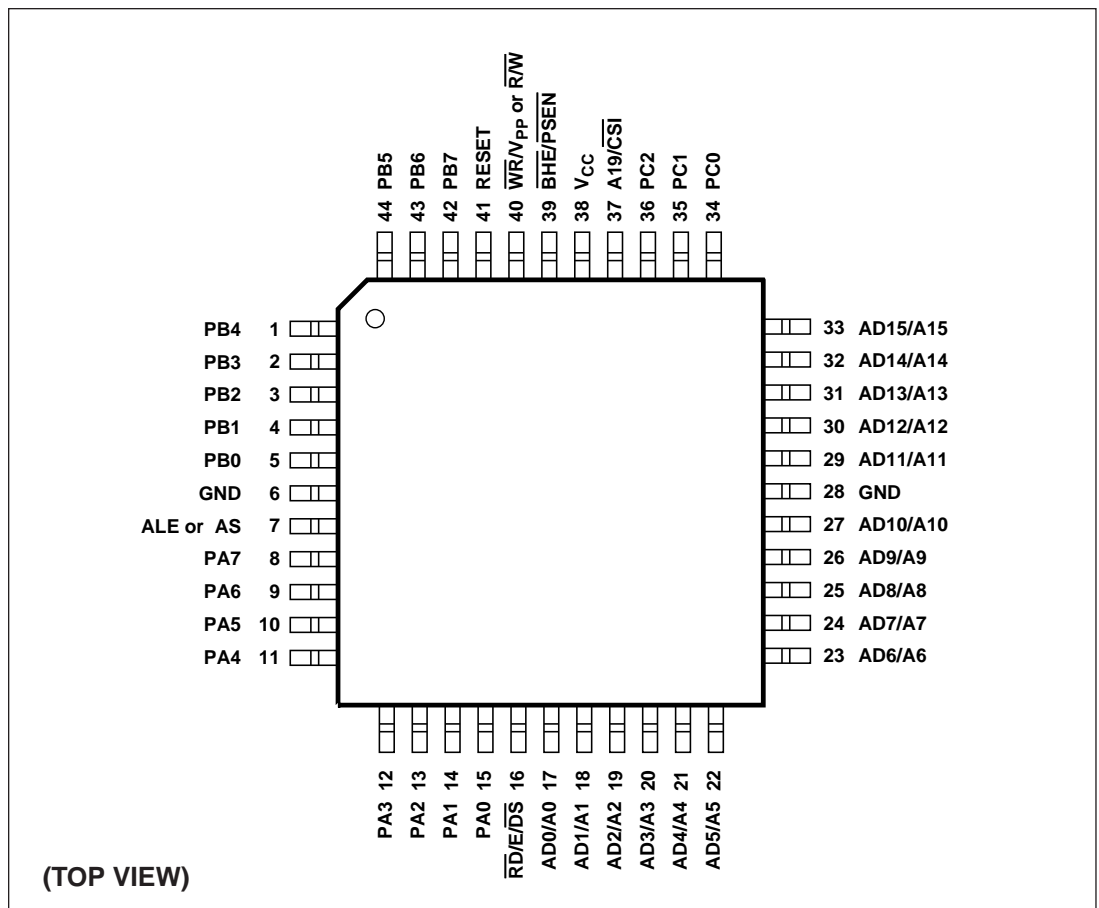
**PSD302
Package
Information**

**Figure 48.
Drawing L4 –
44 Pin Ceramic
Leaded Chip
Carrier (CLDCC)
with Window
(Package Type L)
OR**

**Drawing J2 –
44 Pin Plastic
Leaded Chip
Carrier (PLDCC)
without Window
(Package Type J)**

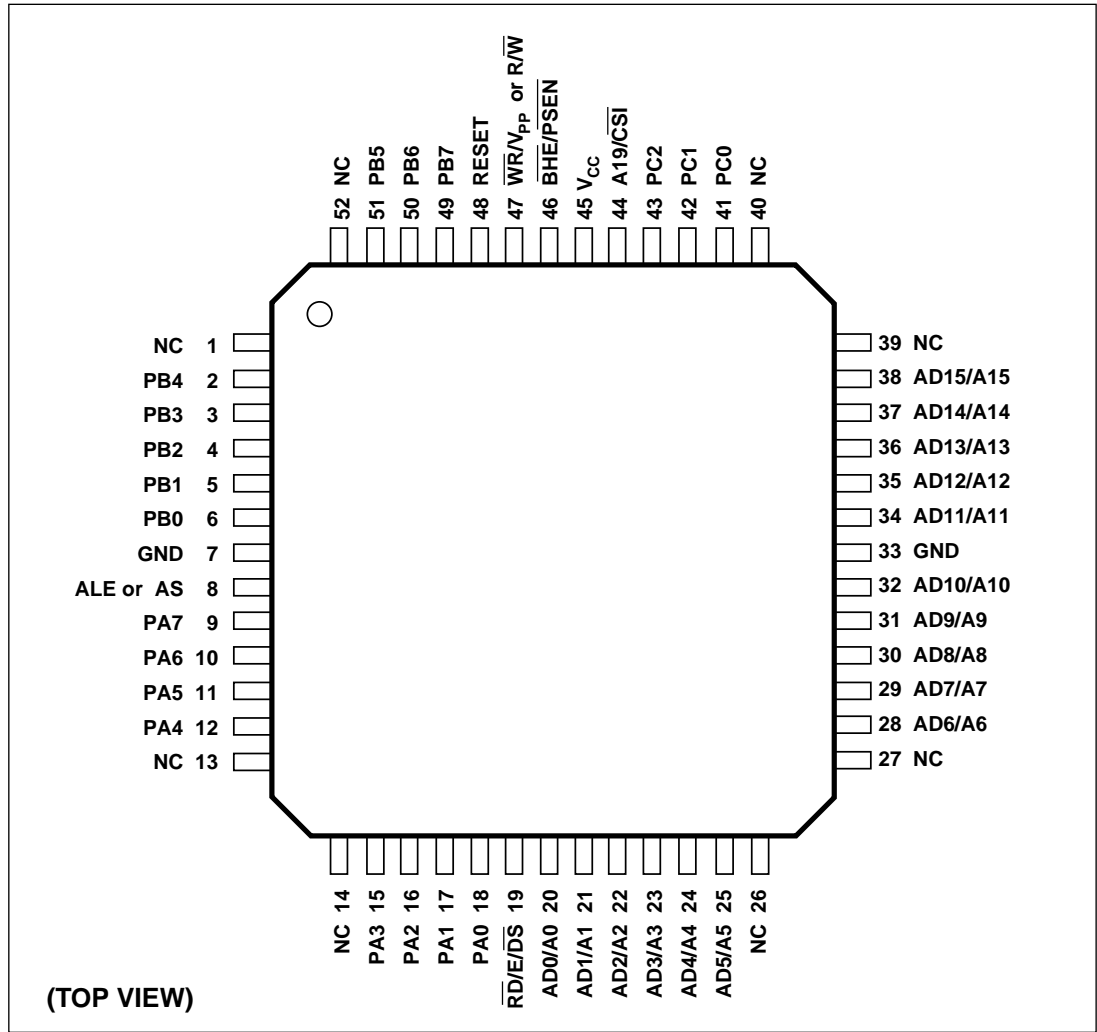


**Figure 49.
Drawing U1 –
44 Pin Plastic
Thin Quad
Flatpack (TQFP)
(Package Type U)**

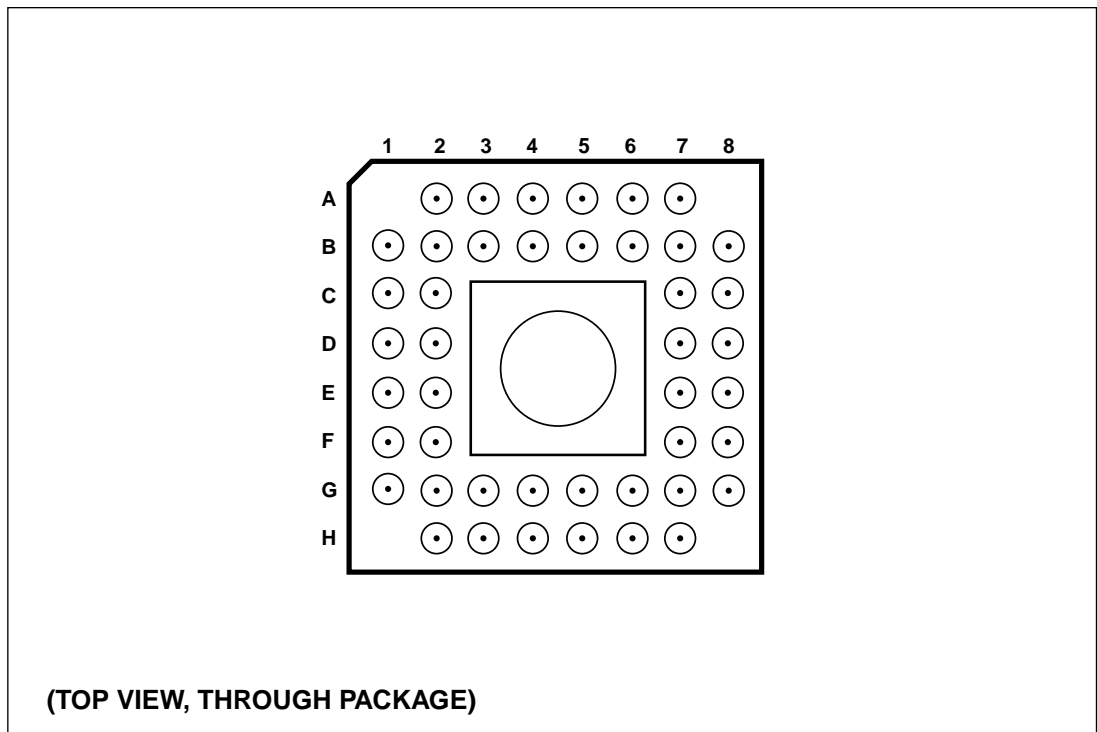


**PSD302
Package
Information**

**Figure 50.
Drawing Q2 –
52 Pin PQFP
(Package Type Q)**



**Figure 51.
Drawing X2 –
44 Pin CPGA
(Package Type X)**





Programmable Peripheral PSD312 Field-Programmable Microcontroller Peripheral

Key Features

- Single Chip Programmable Peripheral for Microcontroller-based Applications
- 19 Individually Configurable I/O pins that can be used as:
 - Microcontroller I/O port expansion
 - Programmable Address Decoder (PAD) I/O
 - Latched address output
 - Open drain or CMOS
- Two Programmable Arrays (PAD A & PAD B)
 - Total of 40 Product Terms and up to 16 Inputs and 24 Outputs
 - Direct Address Decoding up to 1 Meg address space and up to 16 Meg with paging
 - Logic replacement
- “No Glue” Microcontroller Chip-Set
 - Built-in address latches for multiplexed address/data bus
 - Non-multiplexed address/data bus mode
 - 8-bit data bus width
 - ALE and Reset polarity programmable
 - Selectable modes for read and write control bus as $\overline{RD}/\overline{WR}$, $R/\overline{W}/E$, or $R/\overline{W}/\overline{DS}$
 - PSEN pin for 8051 users
- Built-In Page Logic
 - To Expand the Address Space of Microcontrollers with Limited Address Space Capabilities
 - Up to 16 pages
- 512 Kbits of UV EPROM
 - Configured as 64K x 8
 - Divides into 8 equal mappable blocks for optimized mapping
 - Block resolution is 8K x 8
 - 70 ns EPROM access time, including input latches and PAD address decoding.
- 16 Kbit Static RAM
 - Configured as 2K x 8
 - 70 ns SRAM access time, including input latches and PAD address decoding
- Address/Data Track Mode
 - Enables easy Interface to Shared Resources (e.g., Mail Box SRAM) with other Microcontrollers or a Host Processor
- CMiser-Bit
 - Programmable option to further reduce power consumption
- Built-In Security
 - Locks the PSD312 and PAD Decoding Configuration
- Available in a Choice of Packages
 - 44 Pin PLDCC, CLDCC and TQFP
 - 52 Pin PQFP
- Simple Menu-Driven Software:
 - Configure the PSD312 on an IBM PC
- Pin and Function Compatible with the PSD311/311L, PSD313/313L and PSD314R/314RL

**PSD312
Pin
Assignments**

<i>Pin Name</i>	<i>44-Pin PLDCC/CLDCC Package</i>	<i>44-Pin TQFP Package</i>	<i>52-Pin PQFP Package (Note 61)</i>
$\overline{\text{PSEN}}$	1	39	46
$\overline{\text{WR}}/\text{V}_{\text{PP}}$ or $\text{R}/\overline{\text{W}}$	2	40	47
RESET	3	41	48
PB7	4	42	49
PB6	5	43	50
PB5	6	44	51
PB4	7	1	2
PB3	8	2	3
PB2	9	3	4
PB1	10	4	5
PB0	11	5	6
GND	12	6	7
ALE or AS	13	7	8
PA7	14	8	9
PA6	15	9	10
PA5	16	10	11
PA4	17	11	12
PA3	18	12	15
PA2	19	13	16
PA1	20	14	17
PA0	21	15	18
$\overline{\text{RD}}/\text{E}/\overline{\text{DS}}$	22	16	19
AD0/A0	23	17	20
AD1/A1	24	18	21
AD2/A2	25	19	22
AD3/A3	26	20	23
AD4/A4	27	21	24
AD5/A5	28	22	25
AD6/A6	29	23	28
AD7/A7	30	24	29
A8	31	25	30
A9	32	26	31
A10	33	27	32
GND	34	28	33
A11	35	29	34
A12	36	30	35
A13	37	31	36
A14	38	32	37
A15	39	33	38
PC0	40	34	41
PC1	41	35	42
PC2	42	36	43
A19/ $\overline{\text{CSI}}$	43	37	44
V _{CC}	44	38	45

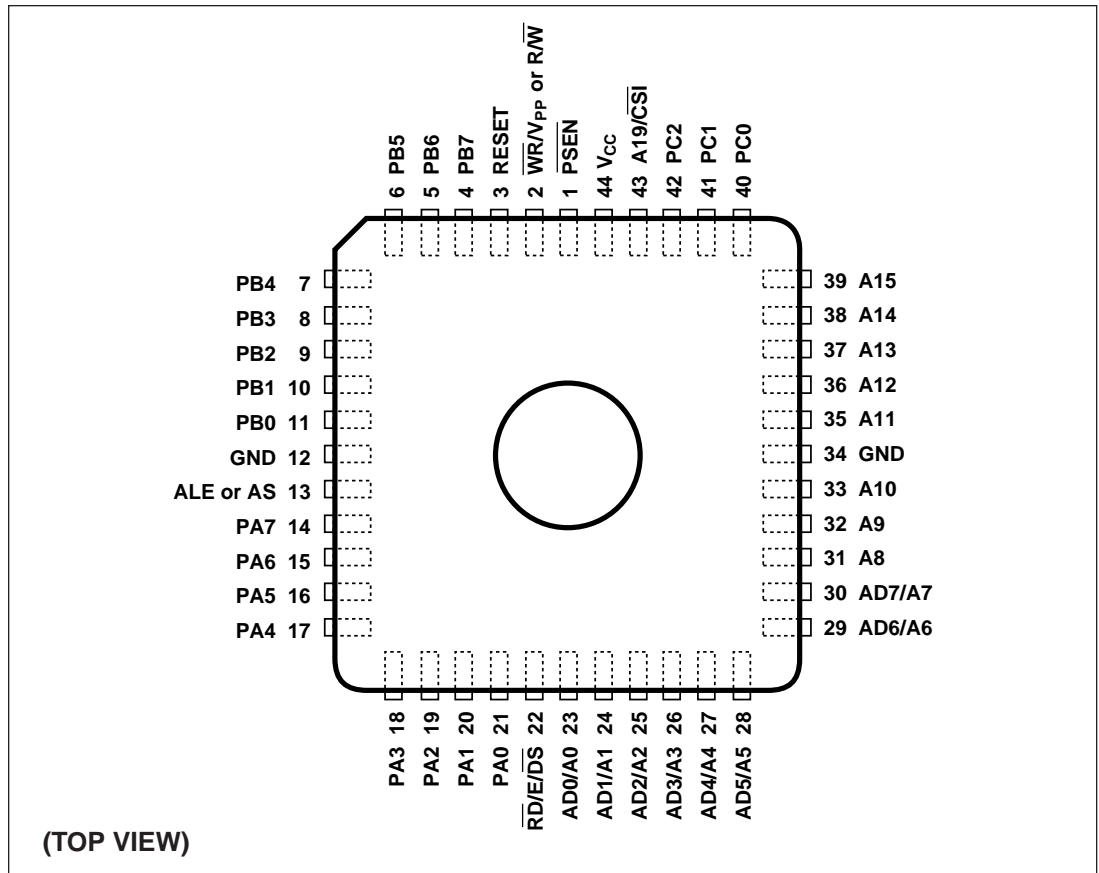
NOTE: 61. Pins 1, 13, 14, 26, 27, 39, 40, and 52 are No Connect.



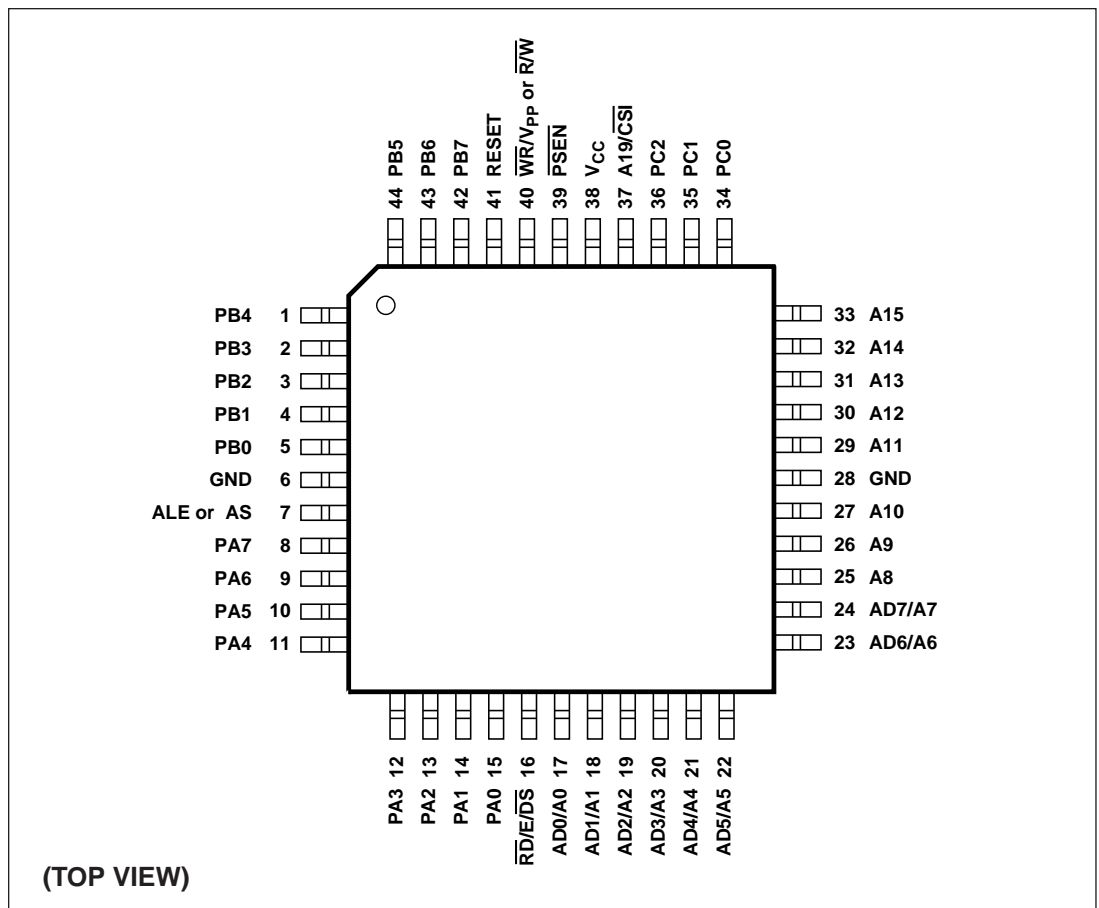
**PSD312
Package
Information**

**Figure 52.
Drawing L4 –
44 Pin Ceramic
Leaded Chip
Carrier (CLDCC)
with Window
(Package Type L)
OR**

**Drawing J2 –
44 Pin Plastic
Leaded Chip
Carrier (PLDCC)
without Window
(Package Type J)**

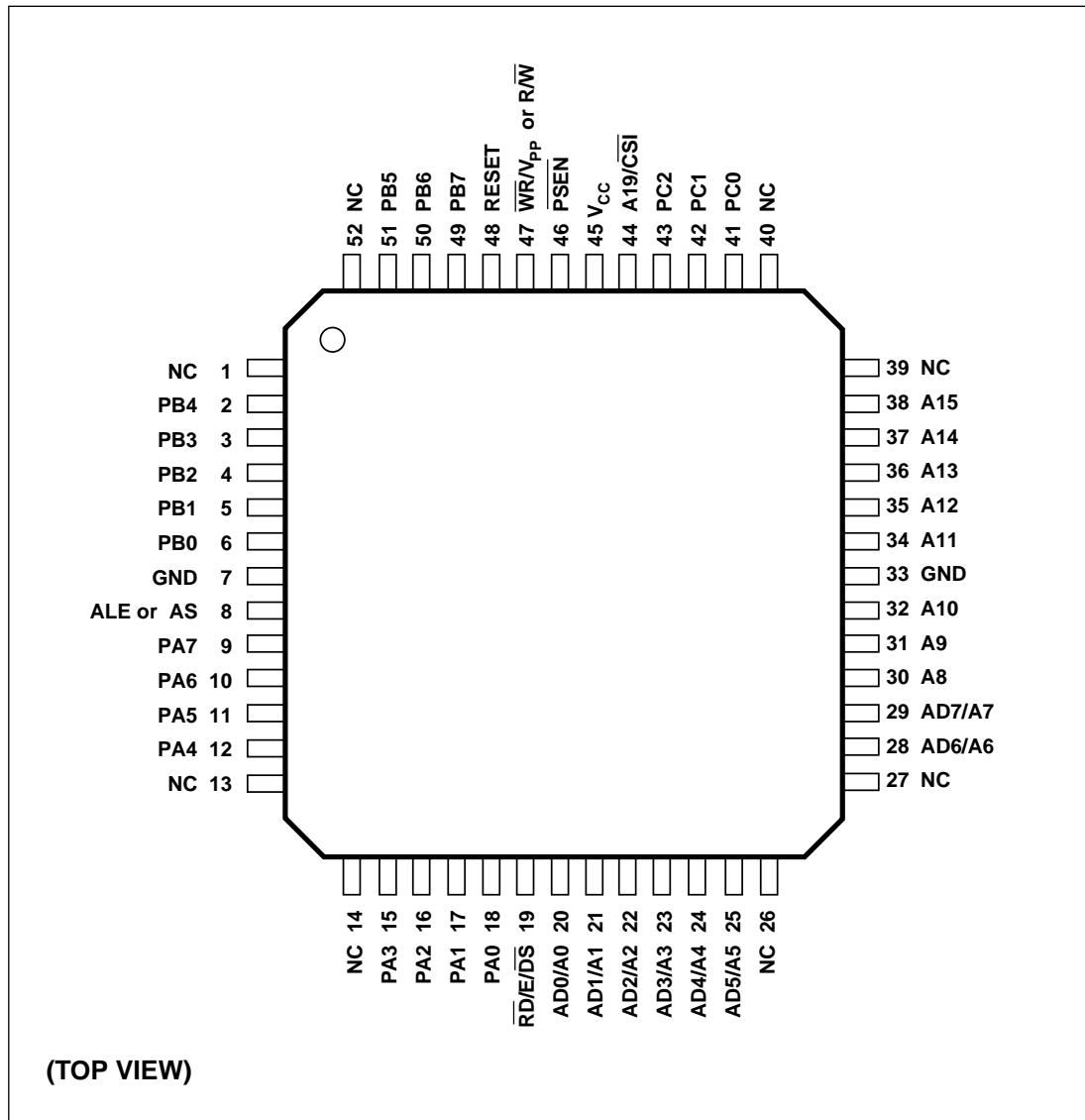


**Figure 53.
Drawing U1 –
44 Pin Plastic
Thin Quad
Flatpack (TQFP)
(Package Type U)**



PSD312
Package
Information

Figure 54.
Drawing Q2 –
52 Pin PQFP
(Package Type Q)





Programmable Peripheral PSD303 Field-Programmable Microcontroller Peripheral

Key Features

- Single Chip Programmable Peripheral for Microcontroller-based Applications
- 19 Individually Configurable I/O pins that can be used as:
 - Microcontroller I/O port expansion
 - Programmable Address Decoder (PAD) I/O
 - Latched address output
 - Open drain or CMOS
- Two Programmable Arrays (PAD A & PAD B)
 - Total of 40 Product Terms and up to 16 Inputs and 24 Outputs
 - Direct Address Decoding up to 1 Meg address space and up to 16 Meg with paging
 - Logic replacement
- “No Glue” Microcontroller Chip-Set
 - Built-in address latches for multiplexed address/data bus
 - Non-multiplexed address/data bus mode
 - Selectable 8 or 16 bit data bus width
 - ALE and Reset polarity programmable
 - Selectable modes for read and write control bus as $\overline{RD}/\overline{WR}$, $R/\overline{W}/E$, or $R/\overline{W}/\overline{DS}$
 - \overline{BHE} pin for byte select in 16-bit mode
 - \overline{PSEN} pin for 8051 users
- Built-In Page Logic
 - To Expand the Address Space of Microcontrollers with Limited Address Space Capabilities
 - Up to 16 pages
- 1 M bit of UV EPROM
 - Configurable as 128K x 8 or as 64K x 16
 - Divides into 8 equal mappable blocks for optimized mapping
 - Block resolution is 16K x 8 or 8K x 16
 - 70 ns EPROM access time, including input latches and PAD address decoding.
- 16 Kbit Static RAM
 - Configurable as 2K x 8 or as 1K x 16
 - 70 ns SRAM access time, including input latches and PAD address decoding
- Address/Data Track Mode
 - Enables easy Interface to Shared Resources (e.g., Mail Box SRAM) with other Microcontrollers or a Host Processor
- Built-In Security
 - Locks the PSD303 and PAD Decoding Configuration
- Available in a Choice of Packages
 - 44 Pin PLDCC, CLDCC and TQFP
 - 44 Pin CPGA
- Simple Menu-Driven Software:
 - Configure the PSD303 on an IBM PC
- Pin and Function Compatible with the PSD301/301L, PSD302/302L and PSD304R/314RL

**PSD303
Pin
Assignments**

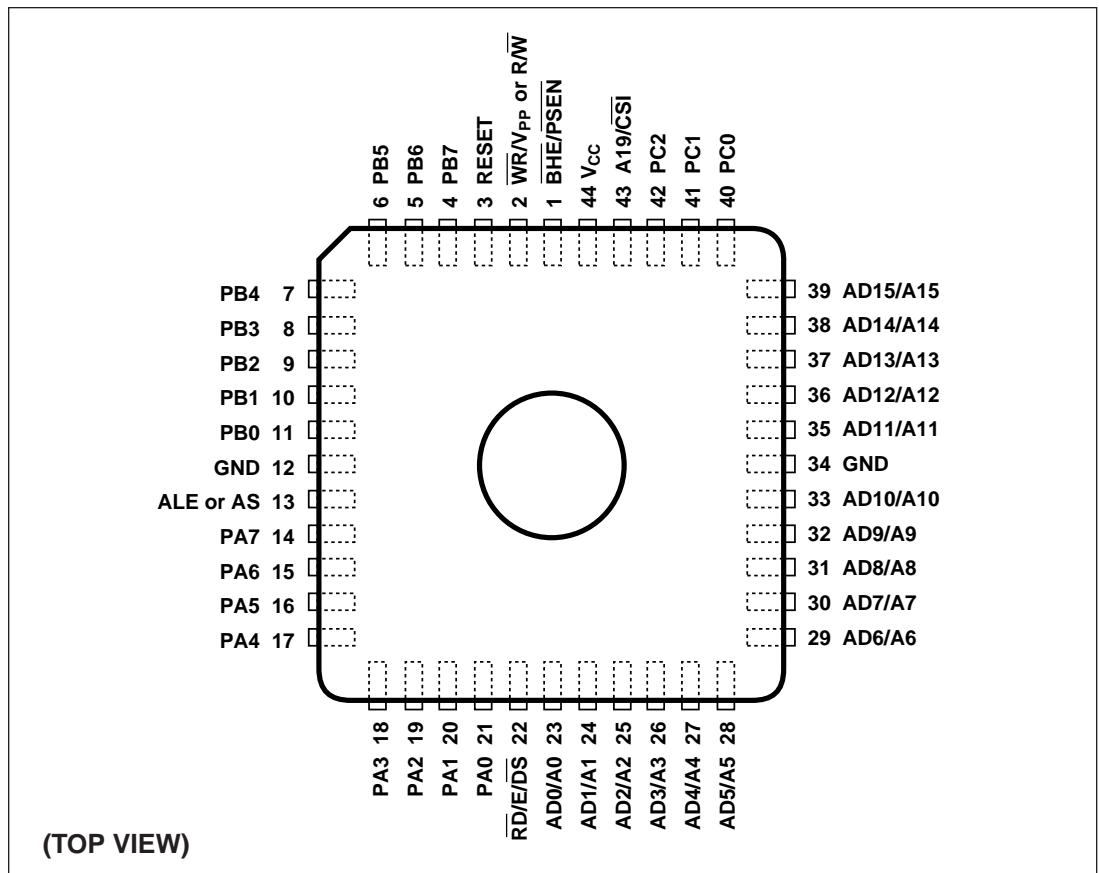
<i>Pin Name</i>	<i>44-Pin PLDCC/CLDCC Package</i>	<i>44-Pin CPGA Package</i>	<i>44-Pin TQFP Package</i>
$\overline{\text{BHE}}/\overline{\text{PSEN}}$	1	A ₅	39
$\overline{\text{WR}}/\text{V}_{\text{PP}}$ or $\text{R}/\overline{\text{W}}$	2	A ₄	40
RESET	3	B ₄	41
PB7	4	A ₃	42
PB6	5	B ₃	43
PB5	6	A ₂	44
PB4	7	B ₂	1
PB3	8	B ₁	2
PB2	9	C ₂	3
PB1	10	C ₁	4
PB0	11	D ₂	5
GND	12	D ₁	6
ALE or AS	13	E ₁	7
PA7	14	E ₂	8
PA6	15	F ₁	9
PA5	16	F ₂	10
PA4	17	G ₁	11
PA3	18	G ₂	12
PA2	19	H ₂	13
PA1	20	G ₃	14
PA0	21	H ₃	15
$\overline{\text{RD}}/\text{E}/\overline{\text{DS}}$	22	G ₄	16
AD0/A0	23	H ₄	17
AD1/A1	24	H ₅	18
AD2/A2	25	G ₅	19
AD3/A3	26	H ₆	20
AD4/A4	27	G ₆	21
AD5/A5	28	H ₇	22
AD6/A6	29	G ₇	23
AD7/A7	30	G ₈	24
AD8/A8	31	F ₇	25
AD9/A9	32	F ₈	26
AD10/A10	33	E ₇	27
GND	34	E ₈	28
AD11/A11	35	D ₈	29
AD12/A12	36	D ₇	30
AD13/A13	37	C ₈	31
AD14/A14	38	C ₇	32
AD15/A15	39	B ₈	33
PC0	40	B ₇	34
PC1	41	A ₇	35
PC2	42	B ₆	36
A19/ $\overline{\text{CSI}}$	43	A ₆	37
V _{CC}	44	B ₅	38



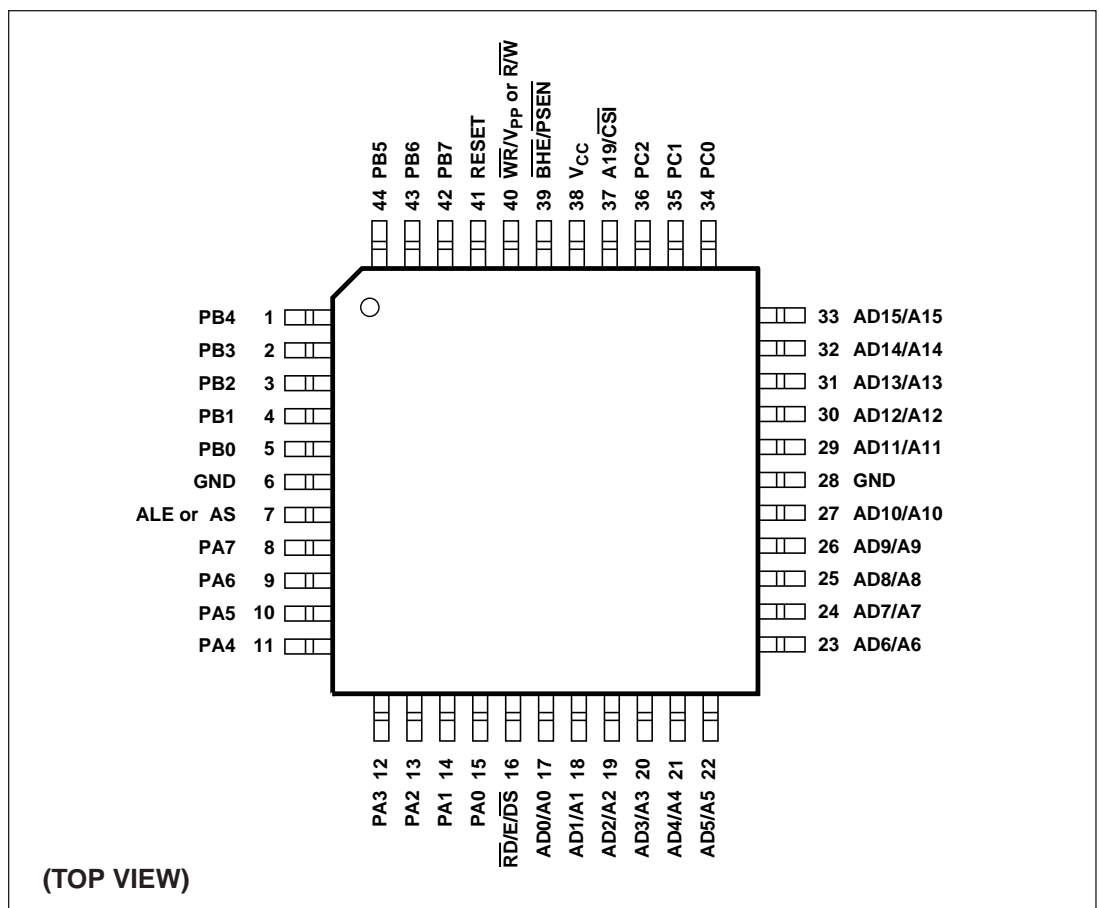
**PSD303
Package
Information**

**Figure 55.
Drawing L4 –
44 Pin Ceramic
Leaded Chip
Carrier (CLDCC)
with Window
(Package Type L)
OR**

**Drawing J2 –
44 Pin Plastic
Leaded Chip
Carrier (PLDCC)
without Window
(Package Type J)**

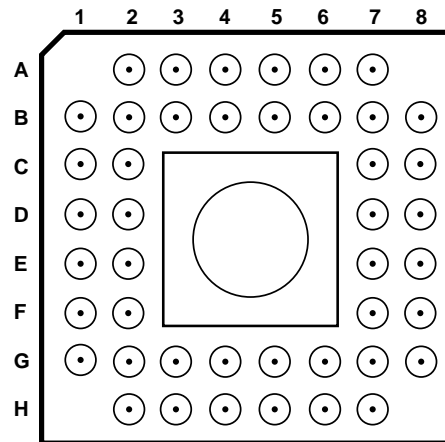


**Figure 56.
Drawing U1 –
44 Pin Plastic
Thin Quad
Flatpack (TQFP)
(Package Type U)**



PSD303
Package
Information

Figure 57.
Drawing X2 –
44 Pin CPGA
(Package Type X)



(TOP VIEW, THROUGH PACKAGE)



Programmable Peripheral PSD313 Field-Programmable Microcontroller Peripheral

Key Features

- Single Chip Programmable Peripheral for Microcontroller-based Applications
- 19 Individually Configurable I/O pins that can be used as:
 - Microcontroller I/O port expansion
 - Programmable Address Decoder (PAD) I/O
 - Latched address output
 - Open drain or CMOS
- Two Programmable Arrays (PAD A & PAD B)
 - Total of 40 Product Terms and up to 16 Inputs and 24 Outputs
 - Direct Address Decoding up to 1 Meg address space and up to 16 Meg with paging
 - Logic replacement
- “No Glue” Microcontroller Chip-Set
 - Built-in address latches for multiplexed address/data bus
 - Non-multiplexed address/data bus mode
 - 8-bit data bus width
 - ALE and Reset polarity programmable
 - Selectable modes for read and write control bus as $\overline{RD}/\overline{WR}$, $R/\overline{W}/E$, or $R/\overline{W}/\overline{DS}$
 - \overline{PSEN} pin for 8051 users
- Built-In Page Logic
 - To Expand the Address Space of Microcontrollers with Limited Address Space Capabilities
 - Up to 16 pages
- 1 M bit of UV EPROM
 - Configurable as 128K x 8
 - Divides into 8 equal mappable blocks for optimized mapping
 - Block resolution is 16K x 8
 - 70 ns EPROM access time, including input latches and PAD address decoding.
- 16 Kbit Static RAM
 - Configurable as 2K x 8
 - 70 ns SRAM access time, including input latches and PAD address decoding
- Address/Data Track Mode
 - Enables easy Interface to Shared Resources (e.g., Mail Box SRAM) with other Microcontrollers or a Host Processor
- Built-In Security
 - Locks the PSD313 and PAD Decoding Configuration
- Available in a Choice of Packages
 - 44 Pin PLDCC, CLDCC and TQFP
 - 52 Pin PQFP
- Simple Menu-Driven Software:
 - Configure the PSD313 on an IBM PC
- Pin and Function Compatible with the PSD311/311L, PSD312/312L and PSD314R/314RL

**PSD313
Pin
Assignments**

<i>Pin Name</i>	<i>44-Pin PLDCC/CLDCC Package</i>	<i>44-Pin TQFP Package</i>	<i>52-Pin PQFP Package (Note 62)</i>
$\overline{\text{PSEN}}$	1	39	46
$\overline{\text{WR}}/\text{V}_{\text{PP}}$ or $\overline{\text{R}}/\overline{\text{W}}$	2	40	47
RESET	3	41	48
PB7	4	42	49
PB6	5	43	50
PB5	6	44	51
PB4	7	1	2
PB3	8	2	3
PB2	9	3	4
PB1	10	4	5
PB0	11	5	6
GND	12	6	7
ALE or AS	13	7	8
PA7	14	8	9
PA6	15	9	10
PA5	16	10	11
PA4	17	11	12
PA3	18	12	15
PA2	19	13	16
PA1	20	14	17
PA0	21	15	18
$\overline{\text{RD}}/\text{E}/\overline{\text{DS}}$	22	16	19
AD0/A0	23	17	20
AD1/A1	24	18	21
AD2/A2	25	19	22
AD3/A3	26	20	23
AD4/A4	27	21	24
AD5/A5	28	22	25
AD6/A6	29	23	28
AD7/A7	30	24	29
A8	31	25	30
A9	32	26	31
A10	33	27	32
GND	34	28	33
A11	35	29	34
A12	36	30	35
A13	37	31	36
A14	38	32	37
A15	39	33	38
PC0	40	34	41
PC1	41	35	42
PC2	42	36	43
A19/ $\overline{\text{CSI}}$	43	37	44
V _{CC}	44	38	45

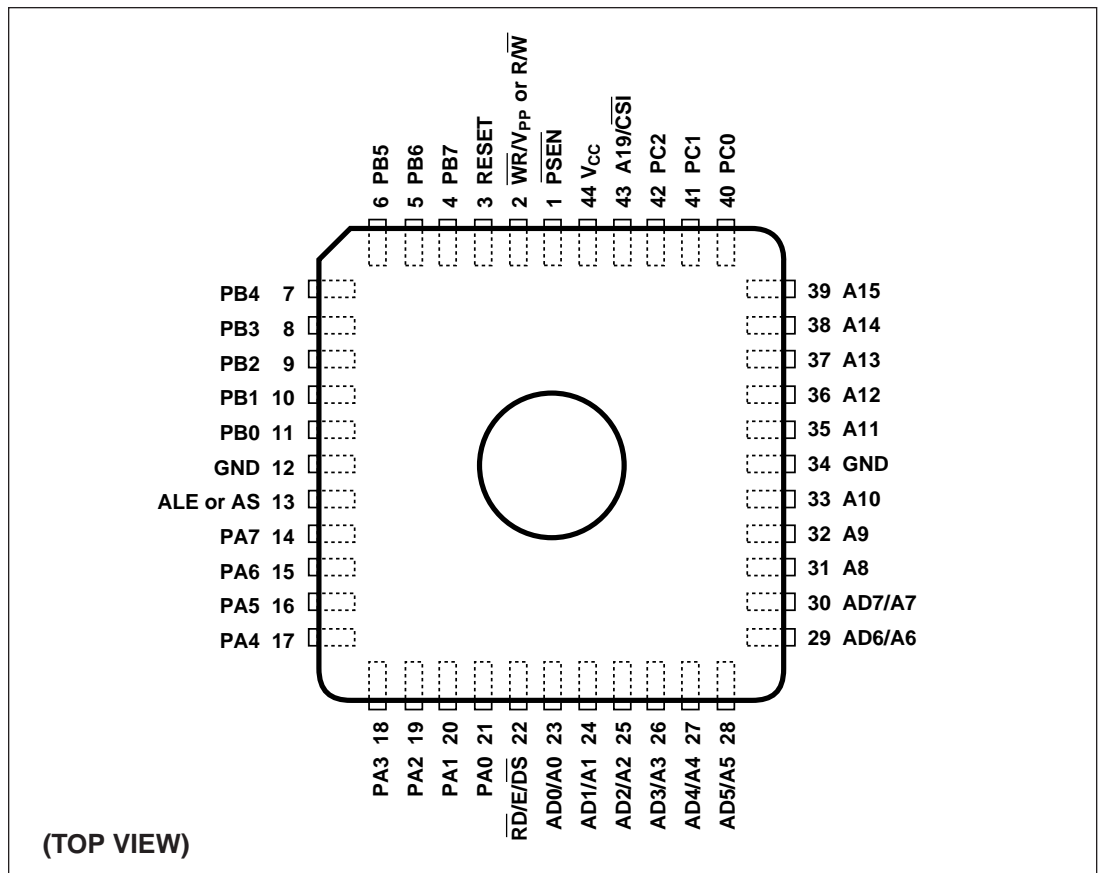
NOTE: 62. Pins 1, 13, 14, 26, 27, 39, 40, and 52 are No Connect.



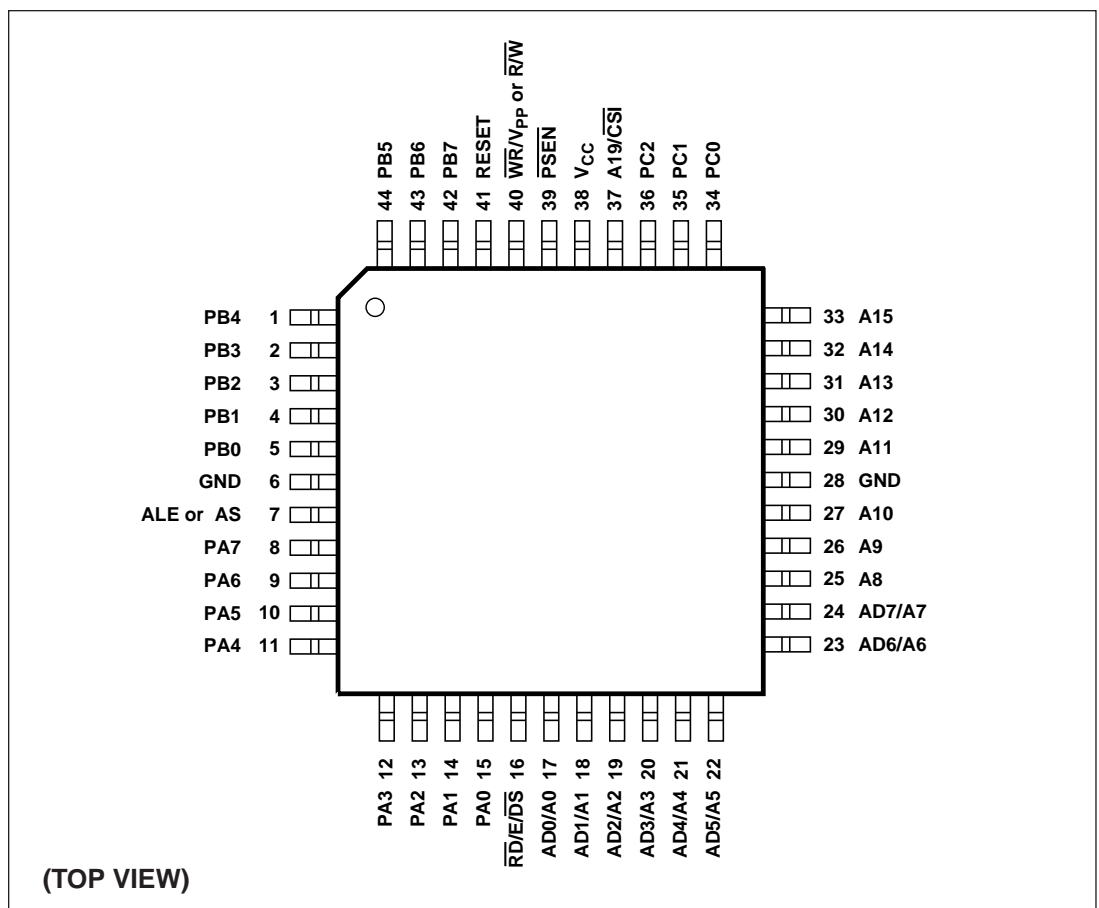
**PSD313
Package
Information**

**Figure 58.
Drawing L4 –
44 Pin Ceramic
Leaded Chip
Carrier (CLDCC)
with Window
(Package Type L)
OR**

**Drawing J2 –
44 Pin Plastic
Leaded Chip
Carrier (PLDCC)
without Window
(Package Type J)**

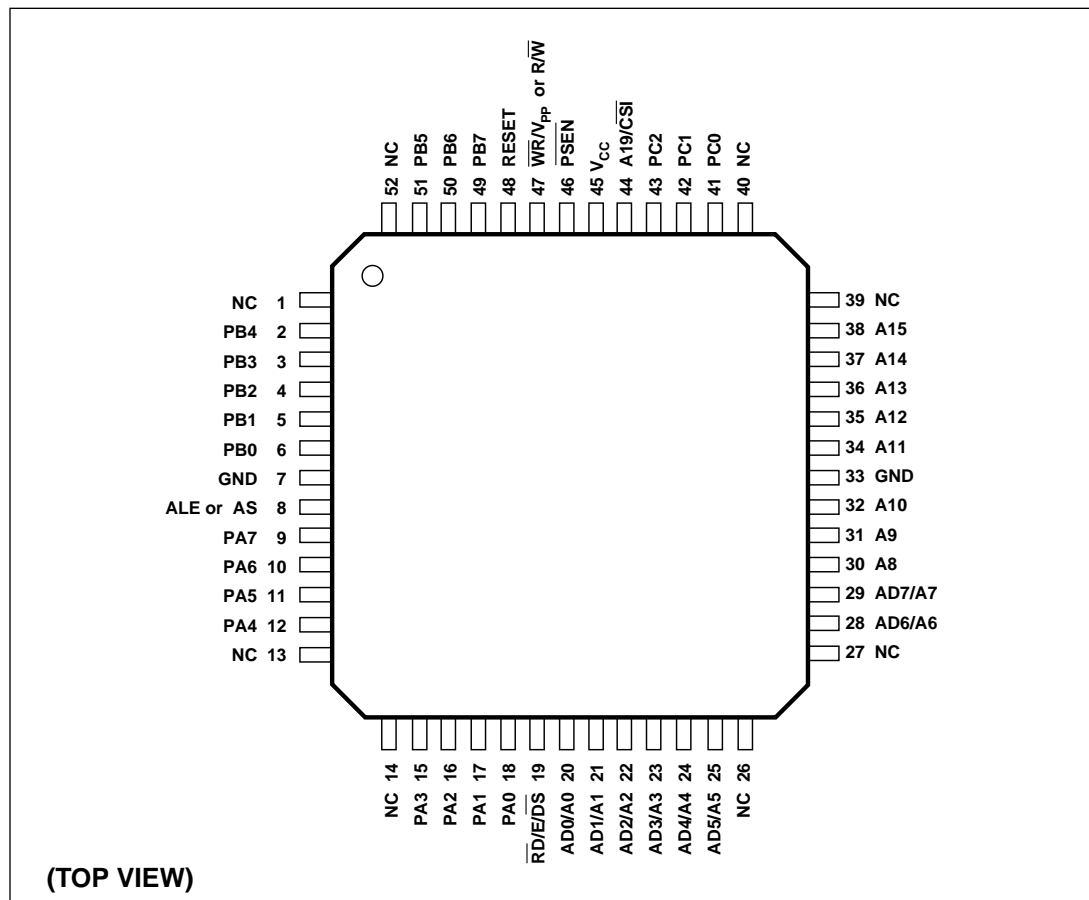


**Figure 59.
Drawing U1 –
44 Pin Plastic
Thin Quad
Flatpack (TQFP)
(Package Type U)**



**PSD313
Package
Information**

**Figure 60.
Drawing Q2 –
52 Pin PQFP
(Package Type Q)**





Programmable Peripheral PSD304R Field-Programmable Microcontroller Peripheral

Key Features

- Single Chip Programmable Peripheral for Microcontroller-based Applications
- 19 Individually Configurable I/O pins that can be used as:
 - Microcontroller I/O port expansion
 - Programmable Address Decoder (PAD) I/O
 - Latched address output
 - Open drain or CMOS
- Two Programmable Arrays (PAD A & PAD B)
 - Total of 40 Product Terms and up to 16 Inputs and 24 Outputs
 - Direct Address Decoding up to 1 Meg address space and up to 16 Meg with paging
 - Logic replacement
- “No Glue” Microcontroller Chip-Set
 - Built-in address latches for multiplexed address/data bus
 - Non-multiplexed address/data bus mode
 - Selectable 8 or 16 bit data bus width
 - ALE and Reset polarity programmable
 - Selectable modes for read and write control bus as $\overline{RD}/\overline{WR}$, $R/\overline{W}/E$, or $R/\overline{W}/\overline{DS}$
 - \overline{BHE} pin for byte select in 16-bit mode
 - \overline{PSEN} pin for 8051 users
- Built-In Page Logic
 - To Expand the Address Space of Microcontrollers with Limited Address Space Capabilities
 - Up to 16 pages
- 2 M bit of UV EPROM
 - Configurable as 256K x 8 or as 128K x 16
 - Divides into 8 equal mappable blocks for optimized mapping
 - Block resolution is 32K x 8 or 16K x 16
 - 120 ns EPROM access time, including input latches and PAD address decoding.
- Address/Data Track Mode
 - Enables easy Interface to Shared Resources (e.g., Mail Box SRAM) with other Microcontrollers or a Host Processor
- Built-In Security
 - Locks the PSD304R and PAD Decoding Configuration
- Available in a Choice of Packages
 - 44 Pin PLDCC, CLDCC and TQFP
 - 44 Pin CPGA
- Simple Menu-Driven Software:
 - Configure the PSD304R on an IBM PC
- Pin and Function Compatible with the PSD301/301L, PSD302/302L and PSD303/303L

**PSD304R
Pin
Assignments**

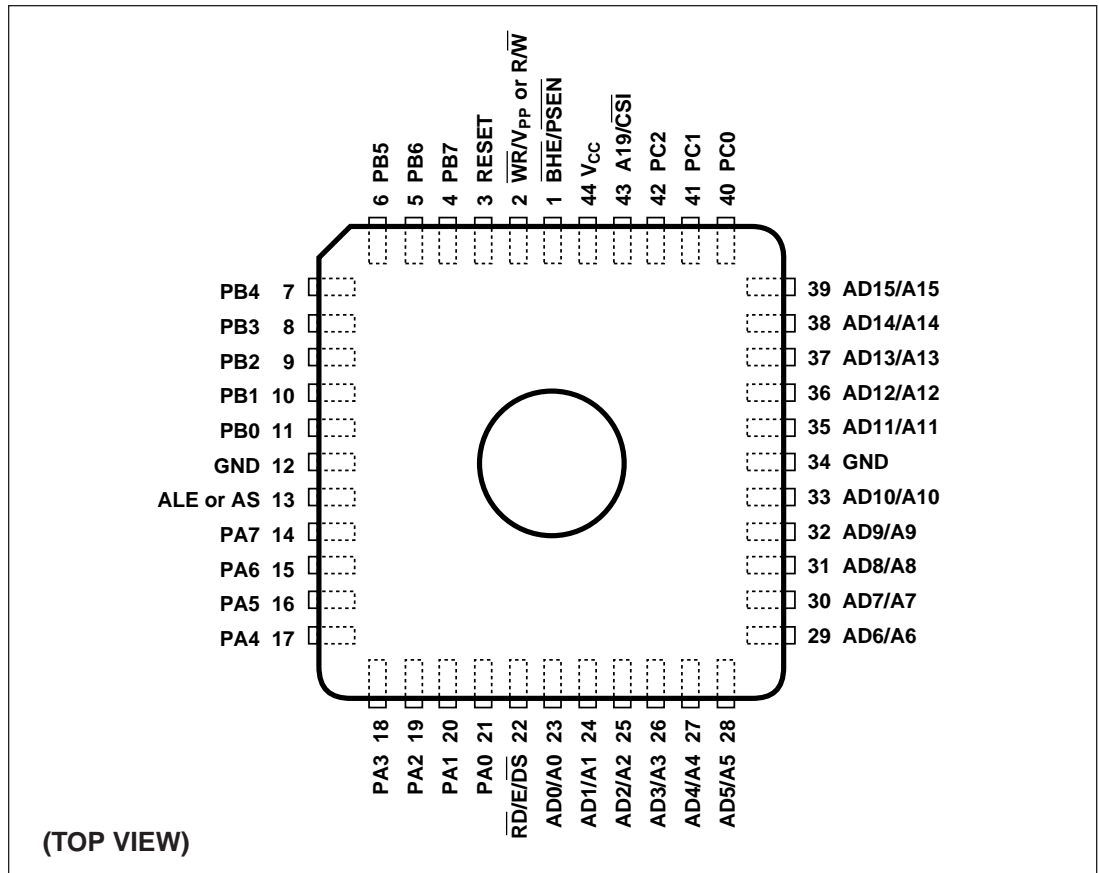
<i>Pin Name</i>	<i>44-Pin PLDCC/CLDCC Package</i>	<i>44-Pin CPGA Package</i>	<i>44-Pin TQFP Package</i>
$\overline{\text{BHE}}/\overline{\text{PSEN}}$	1	A ₅	39
$\overline{\text{WR}}/\text{V}_{\text{PP}}$ or $\text{R}/\overline{\text{W}}$	2	A ₄	40
RESET	3	B ₄	41
PB7	4	A ₃	42
PB6	5	B ₃	43
PB5	6	A ₂	44
PB4	7	B ₂	1
PB3	8	B ₁	2
PB2	9	C ₂	3
PB1	10	C ₁	4
PB0	11	D ₂	5
GND	12	D ₁	6
ALE or AS	13	E ₁	7
PA7	14	E ₂	8
PA6	15	F ₁	9
PA5	16	F ₂	10
PA4	17	G ₁	11
PA3	18	G ₂	12
PA2	19	H ₂	13
PA1	20	G ₃	14
PA0	21	H ₃	15
$\overline{\text{RD}}/\text{E}/\overline{\text{DS}}$	22	G ₄	16
AD0/A0	23	H ₄	17
AD1/A1	24	H ₅	18
AD2/A2	25	G ₅	19
AD3/A3	26	H ₆	20
AD4/A4	27	G ₆	21
AD5/A5	28	H ₇	22
AD6/A6	29	G ₇	23
AD7/A7	30	G ₈	24
AD8/A8	31	F ₇	25
AD9/A9	32	F ₈	26
AD10/A10	33	E ₇	27
GND	34	E ₈	28
AD11/A11	35	D ₈	29
AD12/A12	36	D ₇	30
AD13/A13	37	C ₈	31
AD14/A14	38	C ₇	32
AD15/A15	39	B ₈	33
PC0	40	B ₇	34
PC1	41	A ₇	35
PC2	42	B ₆	36
A19/ $\overline{\text{CSI}}$	43	A ₆	37
V _{CC}	44	B ₅	38



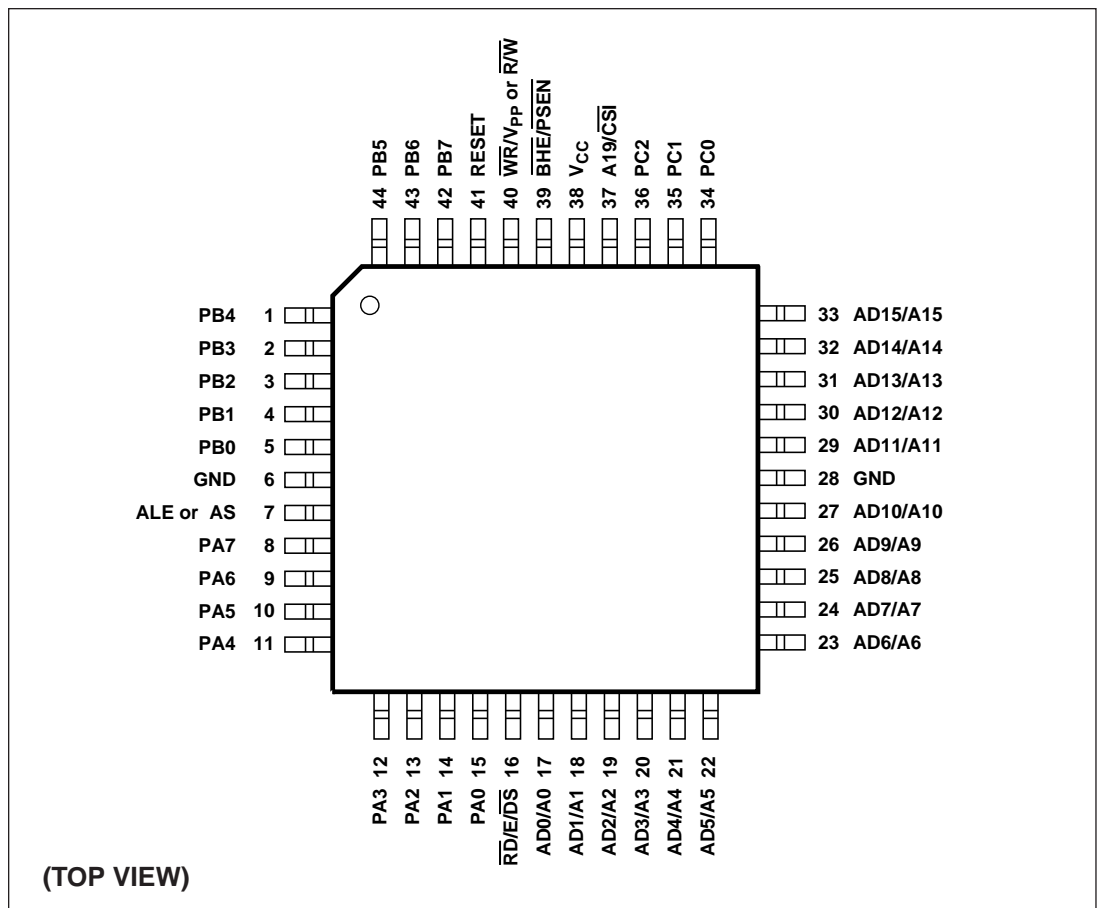
**PSD304R
Package
Information**

**Figure 61.
Drawing L4 –
44 Pin Ceramic
Leaded Chip
Carrier (CLDCC)
with Window
(Package Type L)
OR**

**Drawing J2 –
44 Pin Plastic
Leaded Chip
Carrier (PLDCC)
without Window
(Package Type J)**

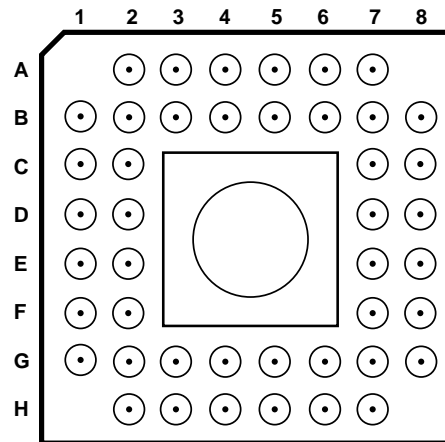


**Figure 62.
Drawing U1 –
44 Pin Plastic
Thin Quad
Flatpack (TQFP)
(Package Type U)**



PSD304R
Package
Information

Figure 63.
Drawing X2 –
44 Pin CPGA
(Package Type X)



(TOP VIEW, THROUGH PACKAGE)



Programmable Peripheral PSD314R Field-Programmable Microcontroller Peripheral

Key Features

- Single Chip Programmable Peripheral for Microcontroller-based Applications
- 19 Individually Configurable I/O pins that can be used as:
 - Microcontroller I/O port expansion
 - Programmable Address Decoder (PAD) I/O
 - Latched address output
 - Open drain or CMOS
- Two Programmable Arrays (PAD A & PAD B)
 - Total of 40 Product Terms and up to 16 Inputs and 24 Outputs
 - Direct Address Decoding up to 1 Meg address space and up to 16 Meg with paging
 - Logic replacement
- “No Glue” Microcontroller Chip-Set
 - Built-in address latches for multiplexed address/data bus
 - Non-multiplexed address/data bus mode
 - 8-bit data bus width
 - ALE and Reset polarity programmable
 - Selectable modes for read and write control bus as $\overline{RD}/\overline{WR}$, $R/\overline{W}/E$, or $R/\overline{W}/\overline{DS}$
 - \overline{PSEN} pin for 8051 users
- Built-In Page Logic
 - To Expand the Address Space of Microcontrollers with Limited Address Space Capabilities
 - Up to 16 pages
- 2 M bit of UV EPROM
 - Configurable as 256K x 8
 - Divides into 8 equal mappable blocks for optimized mapping
 - Block resolution is 32K x 8
 - 120 ns EPROM access time, including input latches and PAD address decoding.
- Address/Data Track Mode
 - Enables easy Interface to Shared Resources (e.g., Mail Box SRAM) with other Microcontrollers or a Host Processor
- Built-In Security
 - Locks the PSD314R and PAD Decoding Configuration
- Available in a Choice of Packages
 - 44 Pin PLDCC, CLDCC and TQFP
 - 52 Pin PQFP
- Simple Menu-Driven Software:
 - Configure the PSD314R on an IBM PC
- Pin and Function Compatible with the PSD311/311L, PSD312/312L and PSD313/313L

**PSD314R
Pin
Assignments**

<i>Pin Name</i>	<i>44-Pin PLDCC/CLDCC Package</i>	<i>44-Pin TQFP Package</i>	<i>52-Pin PQFP Package (Note 63)</i>
$\overline{\text{PSEN}}$	1	39	46
$\overline{\text{WR}}/\text{V}_{\text{PP}}$ or $\text{R}/\overline{\text{W}}$	2	40	47
RESET	3	41	48
PB7	4	42	49
PB6	5	43	50
PB5	6	44	51
PB4	7	1	2
PB3	8	2	3
PB2	9	3	4
PB1	10	4	5
PB0	11	5	6
GND	12	6	7
ALE or AS	13	7	8
PA7	14	8	9
PA6	15	9	10
PA5	16	10	11
PA4	17	11	12
PA3	18	12	15
PA2	19	13	16
PA1	20	14	17
PA0	21	15	18
$\overline{\text{RD}}/\text{E}/\overline{\text{DS}}$	22	16	19
AD0/A0	23	17	20
AD1/A1	24	18	21
AD2/A2	25	19	22
AD3/A3	26	20	23
AD4/A4	27	21	24
AD5/A5	28	22	25
AD6/A6	29	23	28
AD7/A7	30	24	29
A8	31	25	30
A9	32	26	31
A10	33	27	32
GND	34	28	33
A11	35	29	34
A12	36	30	35
A13	37	31	36
A14	38	32	37
A15	39	33	38
PC0	40	34	41
PC1	41	35	42
PC2	42	36	43
A19/ $\overline{\text{CSI}}$	43	37	44
V _{CC}	44	38	45

NOTE: 63. Pins 1, 13, 14, 26, 27, 39, 40, and 52 are No Connect.



PSD314R
Package
Information

Figure 64.
Drawing L4 –
44 Pin Ceramic
Leaded Chip
Carrier (CLDCC)
with Window
(Package Type L)
OR

Drawing J2 –
44 Pin Plastic
Leaded Chip
Carrier (PLDCC)
without Window
(Package Type J)

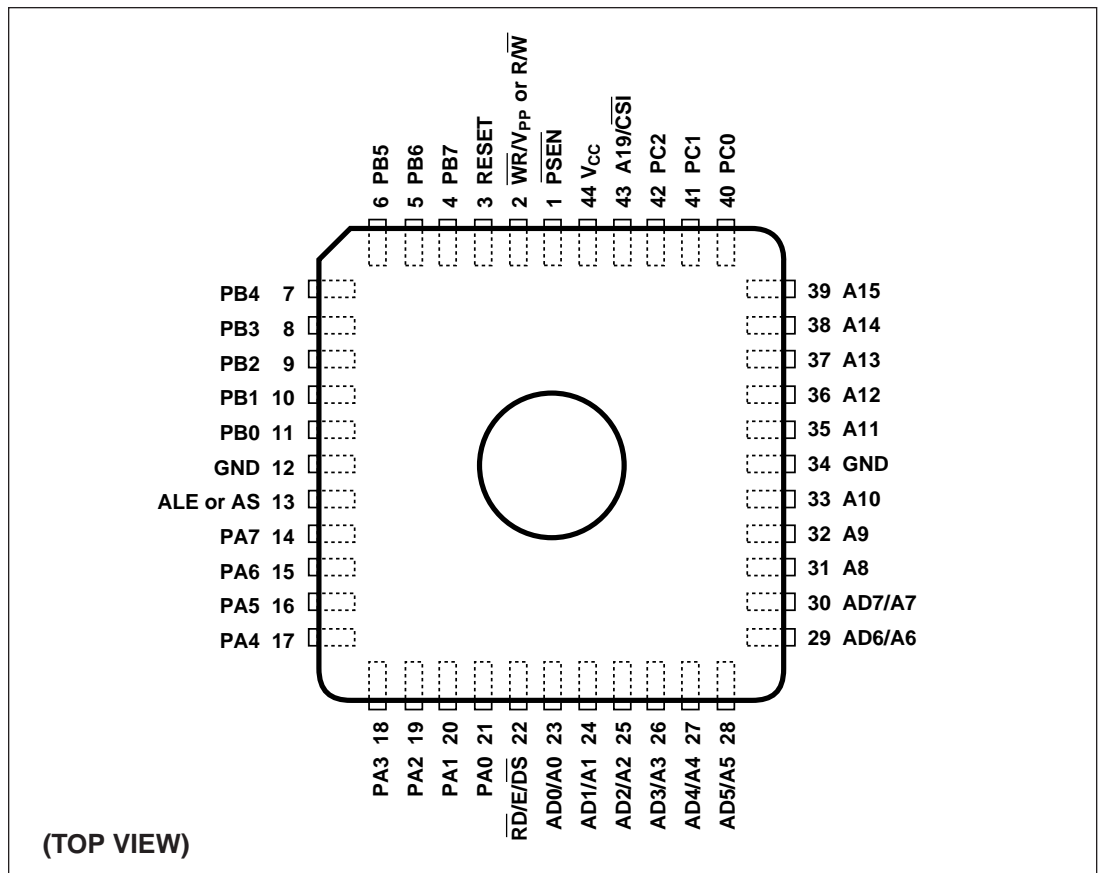
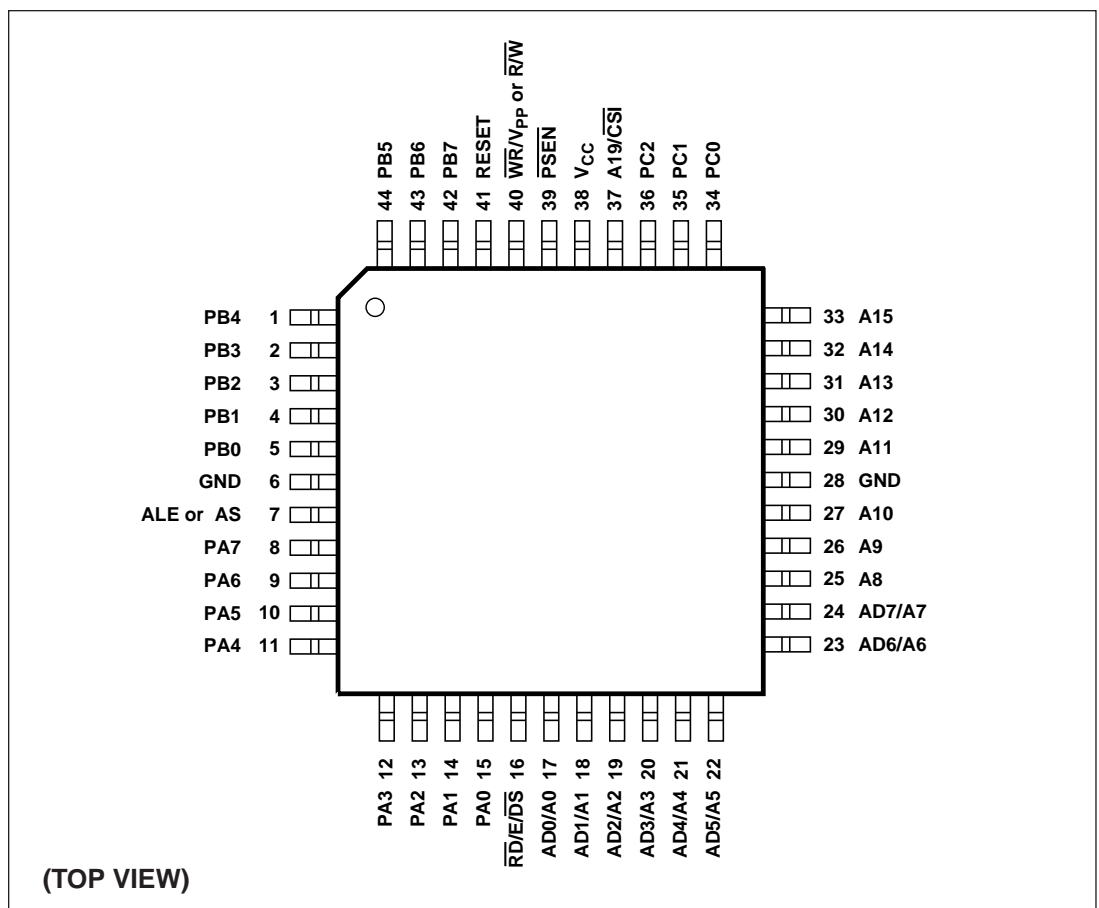
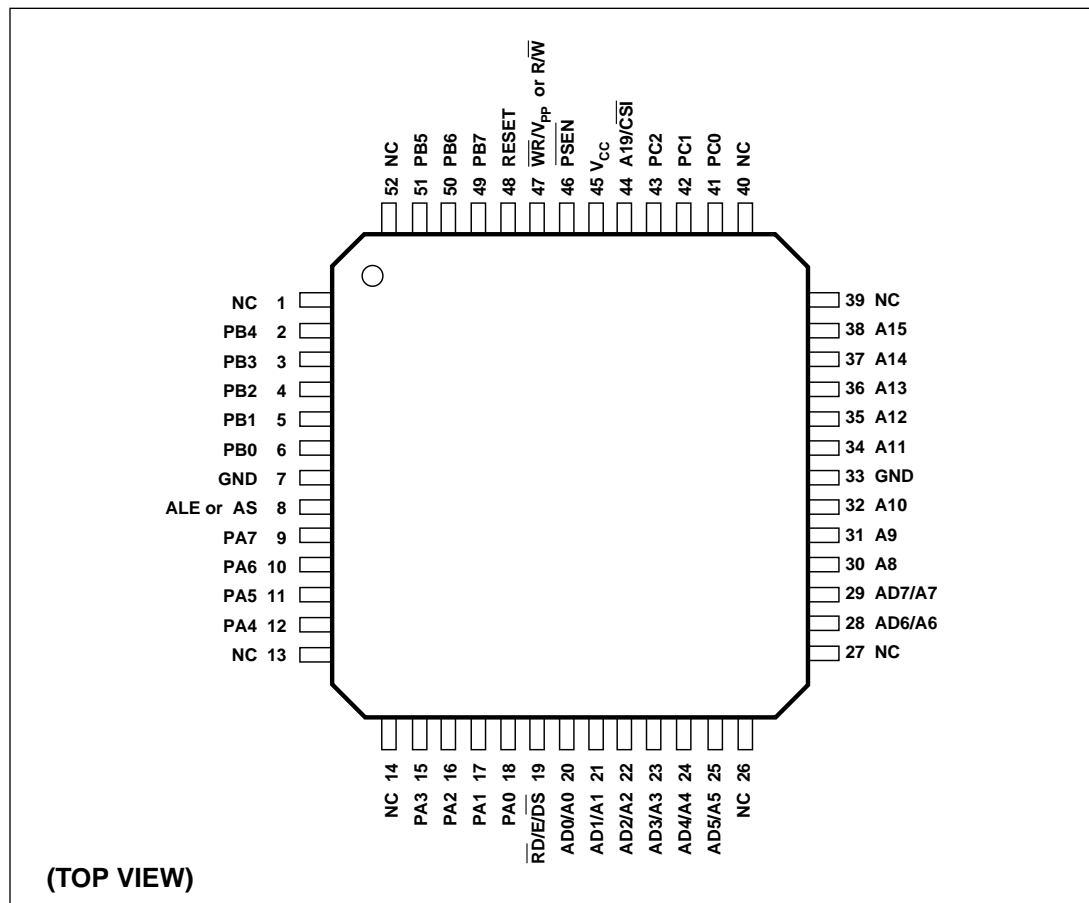


Figure 65.
Drawing U1 –
44 Pin Plastic
Thin Quad
Flatpack (TQFP)
(Package Type U)



PSD314R
Package
Information

Figure 66.
Drawing Q2 –
52 Pin PQFP
(Package Type Q)





Programmable Peripheral PSD301L 3-Volt Single-Chip Microcontroller Peripheral

Key Features

- Single Chip Programmable Peripheral for Microcontroller-based Applications
- 3.0 to 5.5 Volt Operation
- 19 Individually Configurable I/O pins that can be used as:
 - Microcontroller I/O port expansion
 - Programmable Address Decoder (PAD) I/O
 - Latched address output
 - Open drain or CMOS
- Two Programmable Arrays (PAD A and PAD B)
 - Total of 40 Product Terms and up to 12 Inputs and 24 Outputs
 - Address Decoding up to 1 MB
 - Logic replacement
- “No Glue” Microcontroller Chip-Set
 - Built-in address latches for multiplexed address/data bus
 - Non-multiplexed address/data bus mode
 - Selectable 8 or 16 bit data bus width
 - ALE polarity programmable
 - Selectable modes for read and write control bus as $\overline{RD}/\overline{WR}$ or $R/\overline{W}/E$
 - \overline{BHE} pin for byte select in 16-bit mode
 - \overline{PSEN} pin for 8051 users
- 256 Kbits of UV EPROM
 - Configurable as 32K x 8 or as 16K x 16
 - Divides into 8 equal mappable blocks for optimized mapping
 - Block resolution is 4K x 8 or 2K x 16
 - 150 ns EPROM access time, including input latches and PAD address decoding.
- 16 Kbit Static RAM
 - Configurable as 2K x 8 or as 1K x 16
 - 150 ns SRAM access time, including input latches and PAD address decoding
- Address/Data Track Mode
 - Enables easy Interface to Shared Resources (e.g., Mail Box SRAM) with other Microcontrollers or a Host Processor
- Built-In Security
 - Locks the PSD301L and PAD Decoding Configuration
- Available in a Choice of Packages
 - 44 Pin PLDCC, CLDCC and TQFP
- Simple Menu-Driven Software:
 - Configure the PSD301L on an IBM PC
- Pin Compatible with the PSD3XX and PSD3XXL Series

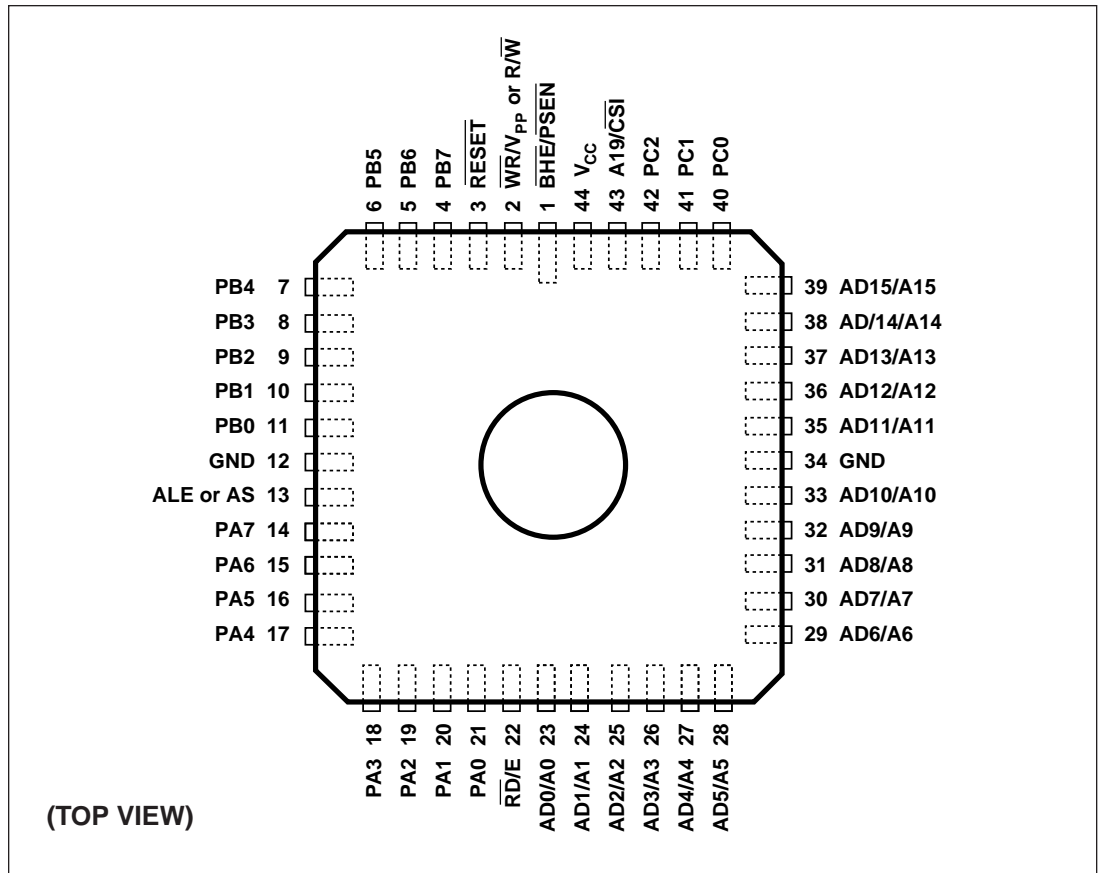
PSD301L
Pin
Assignments

<i>Pin Name</i>	<i>44-Pin PLDCC/CLDCC Package</i>	<i>44-Pin TQFP Package</i>
$\overline{\text{BHE}}/\overline{\text{PSEN}}$	1	39
$\overline{\text{WR}}/\text{V}_{\text{PP}}$ or $\overline{\text{R}}/\overline{\text{W}}$	2	40
$\overline{\text{RESET}}$	3	41
PB7	4	42
PB6	5	43
PB5	6	44
PB4	7	1
PB3	8	2
PB2	9	3
PB1	10	4
PB0	11	5
GND	12	6
ALE or AS	13	7
PA7	14	8
PA6	15	9
PA5	16	10
PA4	17	11
PA3	18	12
PA2	19	13
PA1	20	14
PA0	21	15
$\overline{\text{RD}}/\text{E}$	22	16
AD0/A0	23	17
AD1/A1	24	18
AD2/A2	25	19
AD3/A3	26	20
AD4/A4	27	21
AD5/A5	28	22
AD6/A6	29	23
AD7/A7	30	24
AD8/A8	31	25
AD9/A9	32	26
AD10/A10	33	27
GND	34	28
AD11/A11	35	29
AD12/A12	36	30
AD13/A13	37	31
AD14/A14	38	32
AD15/A15	39	33
PC0	40	34
PC1	41	35
PC2	42	36
A19/ $\overline{\text{CS}}$	43	37
V _{CC}	44	38

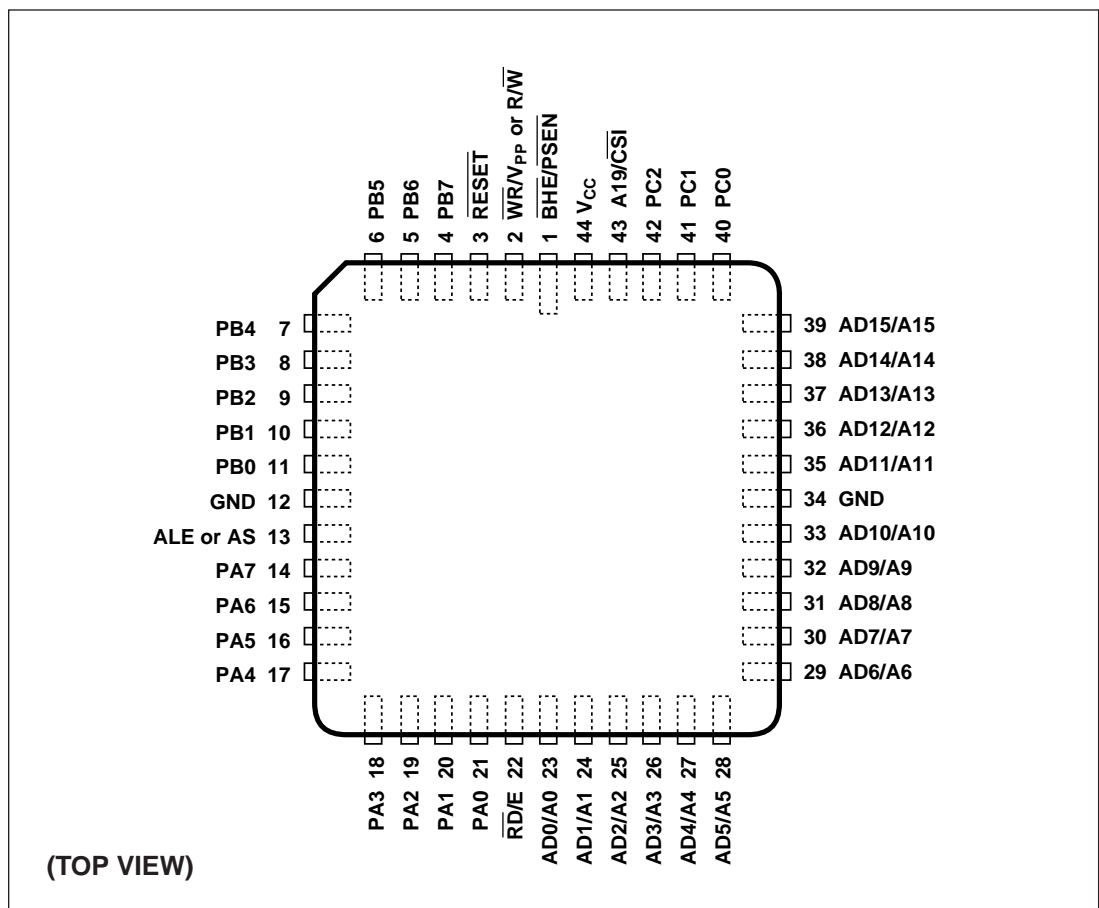


**PSD301L
Package
Information**

**Figure 67.
Drawing L4 –
44 Pin Ceramic
Leaded Chip
Carrier (CLDCC)
with Window
(Package Type L)**

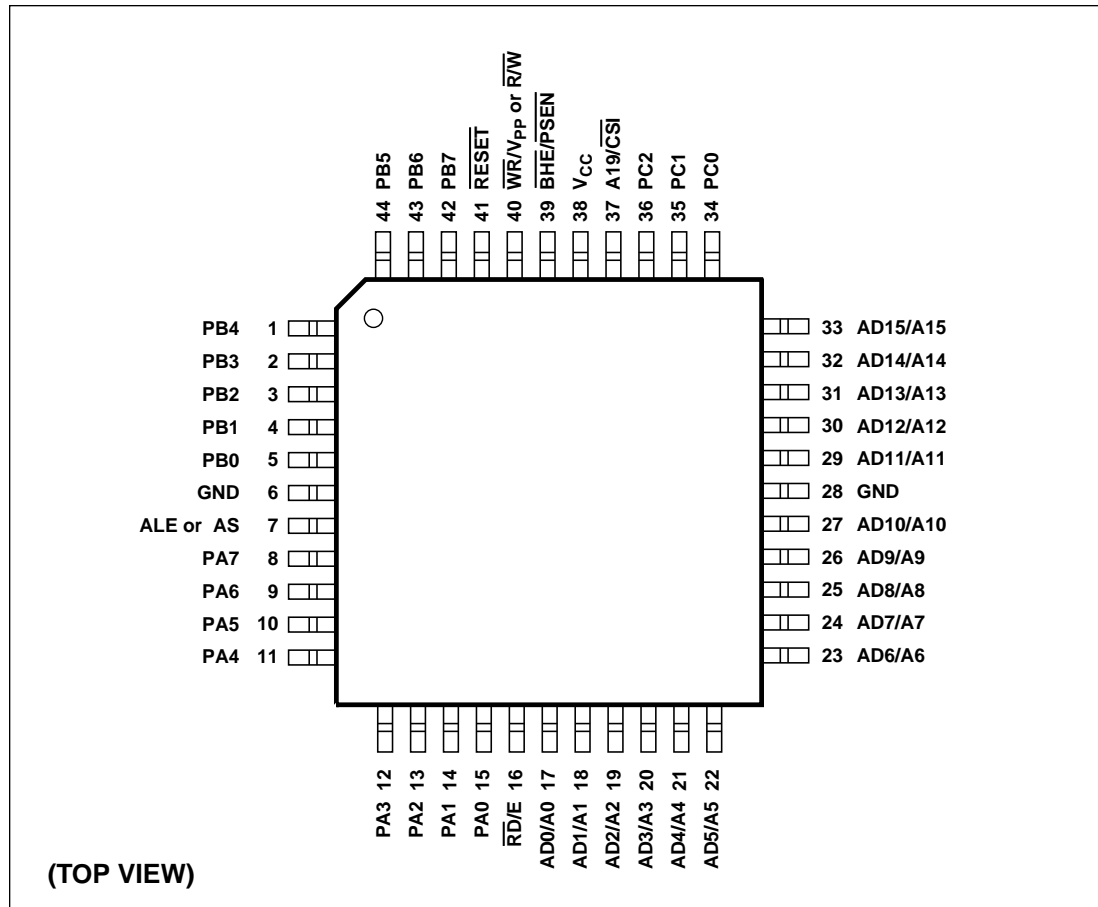


**Figure 68.
Drawing J2 –
44 Pin Plastic
Leaded Chip
Carrier (PLDCC)
(Package Type J)**



PSD301L
Package
Information

Figure 69.
Drawing U1 –
44 Pin
Plastic Thin
Quad Flatpack
(TQFP)
(Package Type U)





Programmable Peripheral PSD311L 3-Volt Single-Chip Microcontroller Peripheral

Key Features

- Single Chip Programmable Peripheral for Microcontroller-based Applications
- 3.0 to 5.5 Volt Operation
- 19 Individually Configurable I/O pins that can be used as:
 - Microcontroller I/O port expansion
 - Programmable Address Decoder (PAD) I/O
 - Latched address output
 - Open drain or CMOS
- Two Programmable Arrays (PAD A and PAD B)
 - Total of 40 Product Terms and up to 12 Inputs and 24 Outputs
 - Address Decoding up to 1 Meg address space
 - Logic replacement
- “No Glue” Microcontroller Chip-Set
 - Built-in address latches for multiplexed address/data bus
 - Non-multiplexed address/data bus mode
 - 8-bit data bus width
 - ALE polarity programmable
 - Selectable modes for read and write control bus as $\overline{RD}/\overline{WR}$ or $R/\overline{W}/E$
 - \overline{PSEN} pin for 8051 users
- 256 Kbits of UV EPROM
 - Organized as 32K x 8
 - Divides into 8 equal mappable blocks for optimized mapping
 - Block resolution is 4K x 8
 - 150 ns EPROM access time, including input latches and PAD address decoding.
- 16 Kbit Static RAM
 - Organized as 2K x 8
 - 150 ns SRAM access time, including input latches and PAD address decoding
- Address/Data Track Mode
 - Enables easy Interface to Shared Resources (e.g., Mail Box SRAM) with other Microcontrollers or a Host Processor
- Built-In Security
 - Locks the PSD311L and PAD Decoding Configuration
- Available in a Choice of Packages
 - 44 Pin PLDCC, CLDCC and TQFP
- Simple Menu-Driven Software:
 - Configure the PSD311L on an IBM PC
- Pin Compatible with the PSD3XX and PSD3XXL Series

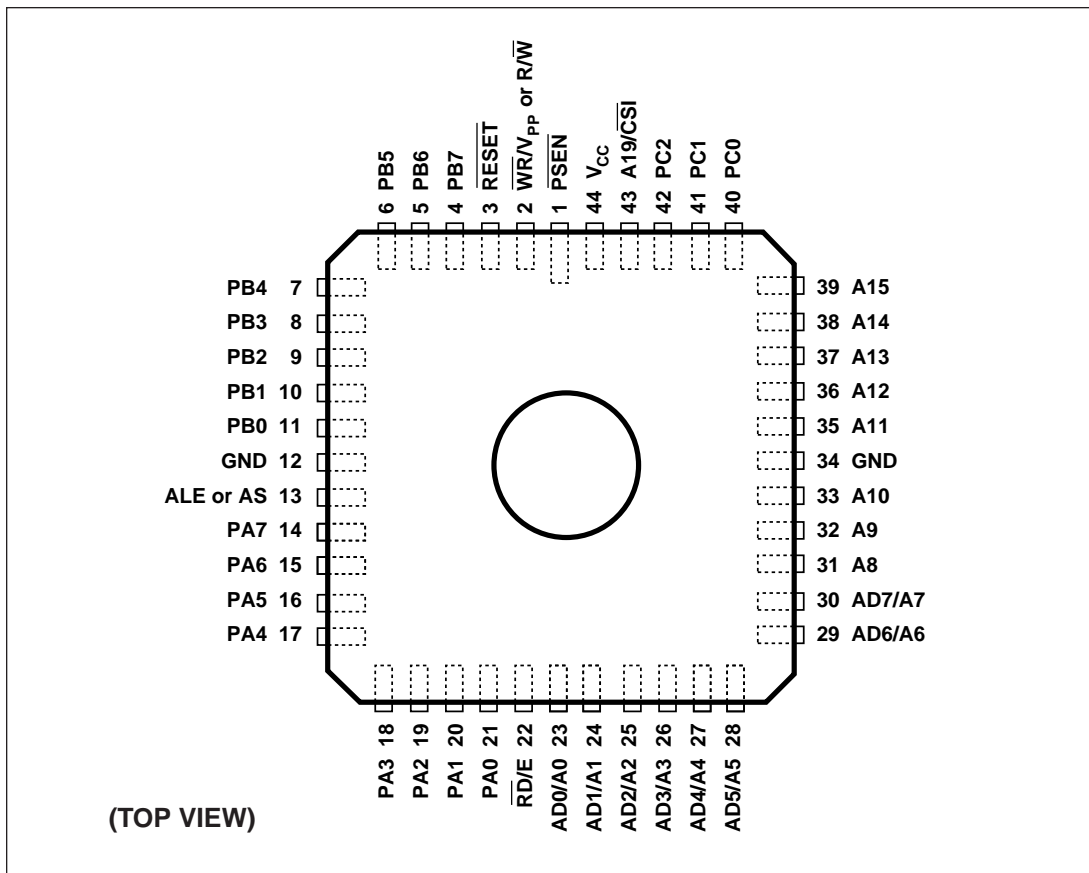
PSD311L
Pin
Assignments

<i>Pin Name</i>	<i>44-Pin PLDCC/CLDCC Package</i>	<i>44-Pin TQFP Package</i>
$\overline{\text{PSEN}}$	1	39
$\overline{\text{WR}}/\text{V}_{\text{PP}}$ or $\text{R}/\overline{\text{W}}$	2	40
$\overline{\text{RESET}}$	3	41
PB7	4	42
PB6	5	43
PB5	6	44
PB4	7	1
PB3	8	2
PB2	9	3
PB1	10	4
PB0	11	5
GND	12	6
ALE or AS	13	7
PA7	14	8
PA6	15	9
PA5	16	10
PA4	17	11
PA3	18	12
PA2	19	13
PA1	20	14
PA0	21	15
$\overline{\text{RD}}/\text{E}$	22	16
AD0/A0	23	17
AD1/A1	24	18
AD2/A2	25	19
AD3/A3	26	20
AD4/A4	27	21
AD5/A5	28	22
AD6/A6	29	23
AD7/A7	30	24
A8	31	25
A9	32	26
A10	33	27
GND	34	28
A11	35	29
A12	36	30
A13	37	31
A14	38	32
A15	39	33
PC0	40	34
PC1	41	35
PC2	42	36
A19/ $\overline{\text{CS}}$	43	37
V _{CC}	44	38

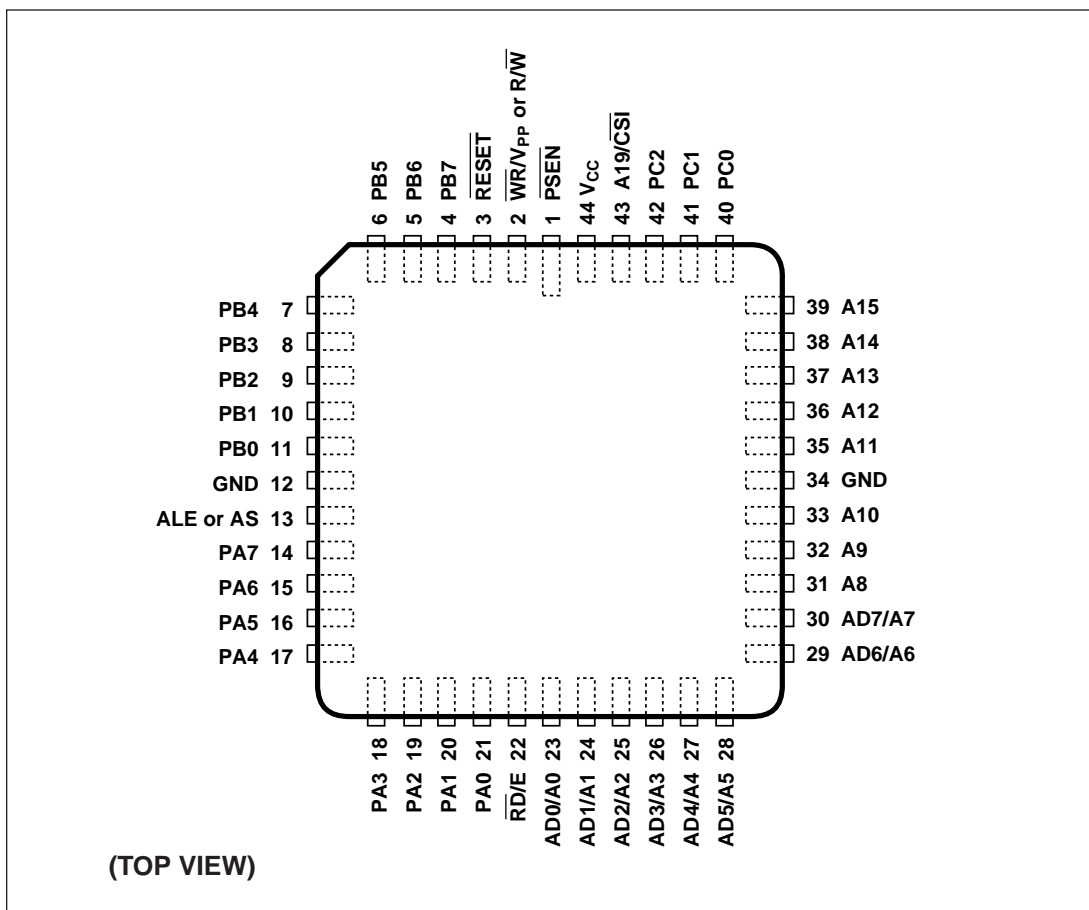


**PSD311L
Package
Information**

**Figure 70.
Drawing L4 —
44 Pin Ceramic
Leaded Chip
Carrier (CLDCC)
with Window
(Package Type L)**

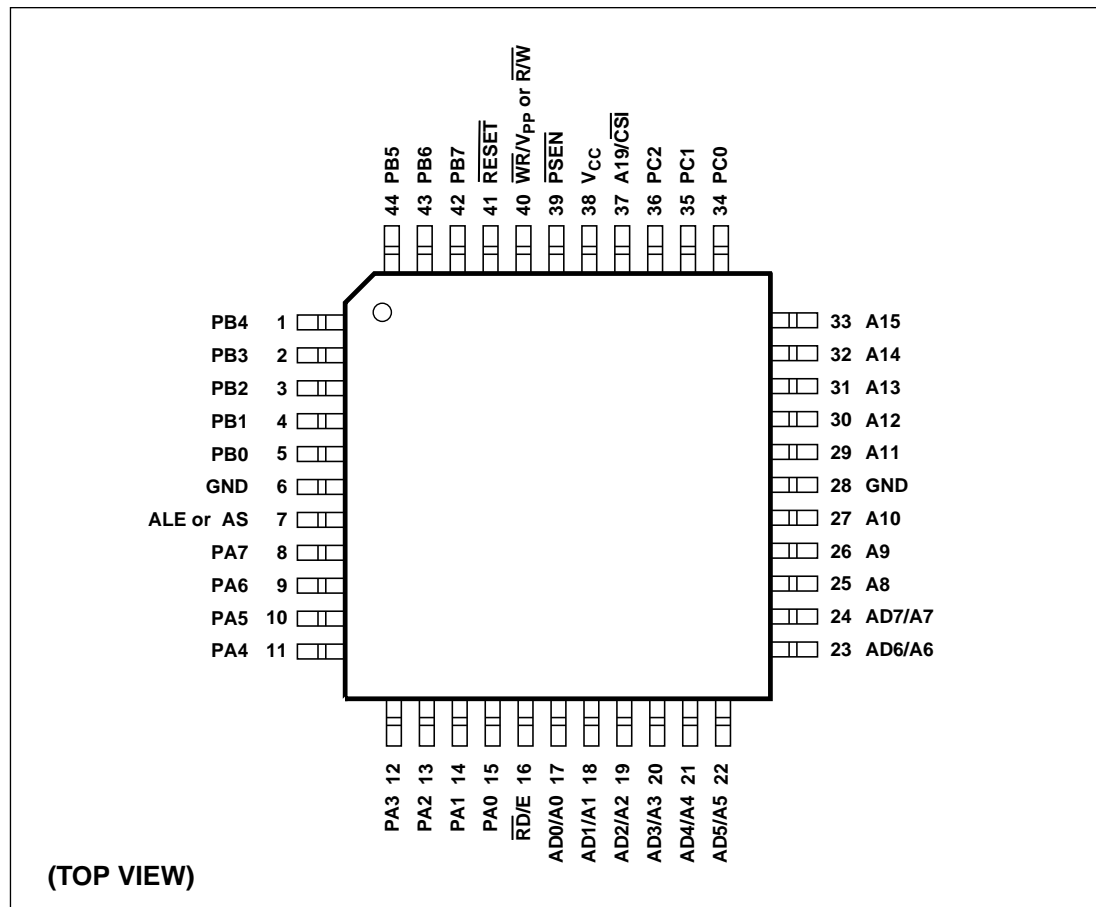


**Figure 71.
Drawing J2 —
44 Pin Plastic
Leaded Chip
Carrier (PLDCC)
(Package Type J)**



PSD311L
Package
Information

Figure 72.
Drawing U1 —
44 Pin Plastic
Thin Quad
Flatpack
(TQFP)
(Package Type U)





Programmable Peripheral PSD302L 3-Volt Single-Chip Microcontroller Peripheral

Key Features

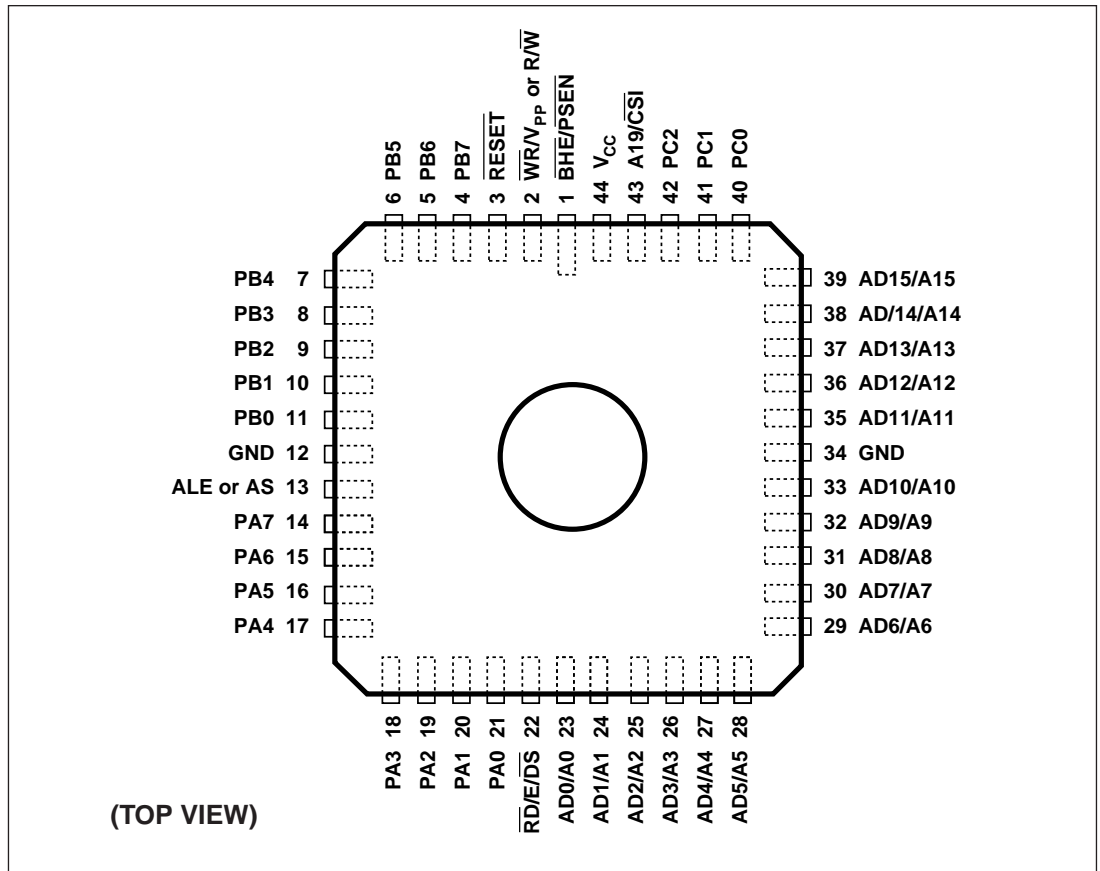
- Single Chip Programmable Peripheral for Microcontroller-based Applications
- 3.0 to 5.5 Volt Operation
- 19 Individually Configurable I/O pins that can be used as:
 - Microcontroller I/O port expansion
 - Programmable Address Decoder (PAD) I/O
 - Latched address output
 - Open drain or CMOS
- Two Programmable Arrays (PAD A & PAD B)
 - Total of 40 Product Terms and up to 16 Inputs and 24 Outputs
 - Direct Address Decoding up to 1 Meg address space and up to 16 Meg with paging
 - Logic replacement
- “No Glue” Microcontroller Chip-Set
 - Built-in address latches for multiplexed address/data bus
 - Non-multiplexed address/data bus mode
 - Selectable 8 or 16 bit data bus width
 - ALE polarity programmable
 - Selectable modes for read and write control bus as $\overline{RD}/\overline{WR}$, $R/\overline{W}/E$, or $R/\overline{W}/\overline{DS}$
 - \overline{BHE} pin for byte select in 16-bit mode
 - \overline{PSEN} pin for 8051 users
- Built-In Page Logic
 - To Expand the Address Space of Microcontrollers with Limited Address Space Capabilities
 - Up to 16 pages
- 512 Kbits of UV EPROM
 - Configurable as 64K x 8 or as 32K x 16
 - Divides into 8 equal mappable blocks for optimized mapping
 - Block resolution is 8K x 8 or 4K x 16
 - 150 ns EPROM access time, including input latches and PAD address decoding.
- 16 Kbit Static RAM
 - Configurable as 2K x 8 or as 1K x 16
 - 150 ns SRAM access time, including input latches and PAD address decoding
- Address/Data Track Mode
 - Enables easy Interface to Shared Resources (e.g., Mail Box SRAM) with other Microcontrollers or a Host Processor
- CMiser-Bit
 - Programmable option to further reduce power consumption
- Built-In Security
 - Locks the PSD302L and PAD Decoding Configuration
- Available in a Choice of Packages
 - 44 Pin PLDCC, CLDCC and TQFP
- Simple Menu-Driven Software:
 - Configure the PSD302L on an IBM PC
- Pin and Functionally Compatible with the PSD3XX and PSD3XXL Series

**PSD302L
Pin
Assignments**

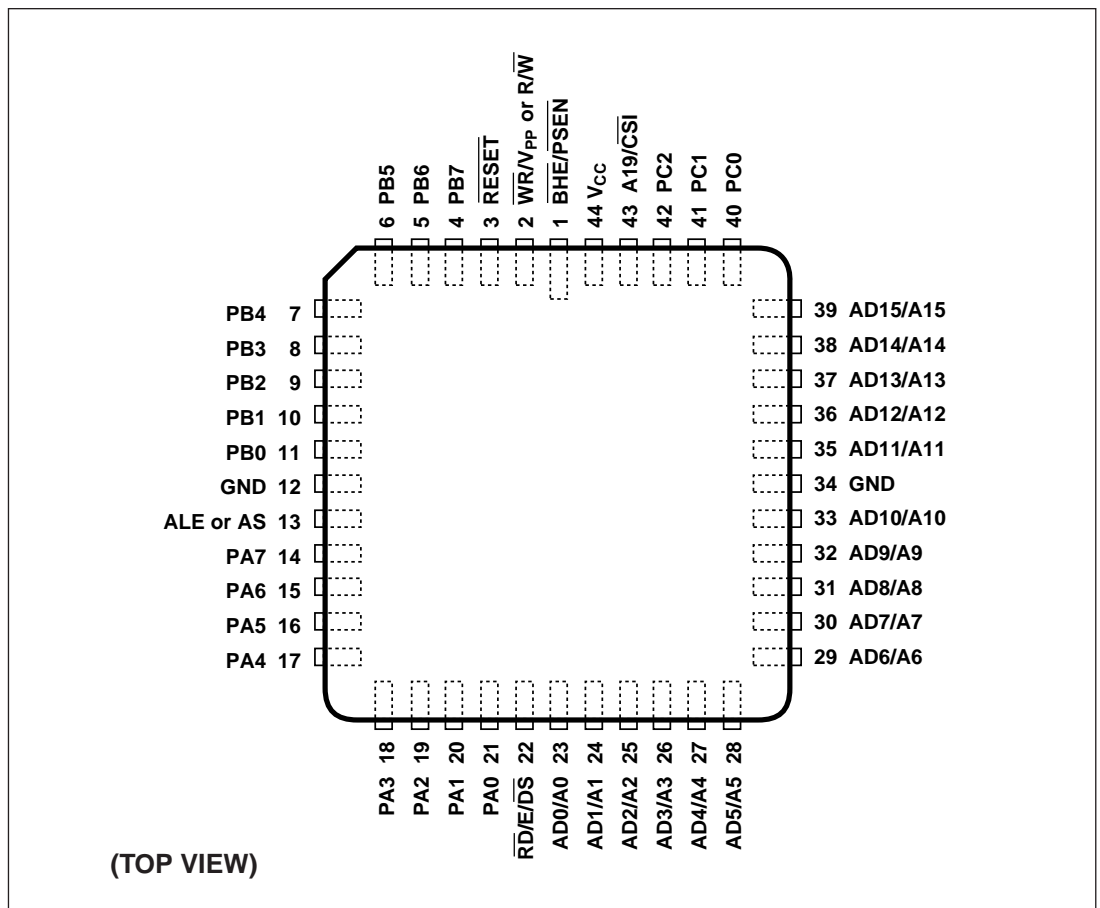
<i>Pin Name</i>	<i>44-Pin PLDCC/CLDCC Package</i>	<i>44-Pin TQFP Package</i>
$\overline{\text{BHE}}/\overline{\text{PSEN}}$	1	39
$\overline{\text{WR}}/\overline{\text{V}}_{\text{PP}}$ or $\overline{\text{R}}/\overline{\text{W}}$	2	40
$\overline{\text{RESET}}$	3	41
PB7	4	42
PB6	5	43
PB5	6	44
PB4	7	1
PB3	8	2
PB2	9	3
PB1	10	4
PB0	11	5
GND	12	6
ALE or AS	13	7
PA7	14	8
PA6	15	9
PA5	16	10
PA4	17	11
PA3	18	12
PA2	19	13
PA1	20	14
PA0	21	15
$\overline{\text{RD}}/\overline{\text{E}}/\overline{\text{DS}}$	22	16
AD0/A0	23	17
AD1/A1	24	18
AD2/A2	25	19
AD3/A3	26	20
AD4/A4	27	21
AD5/A5	28	22
AD6/A6	29	23
AD7/A7	30	24
AD8/A8	31	25
AD9/A9	32	26
AD10/A10	33	27
GND	34	28
AD11/A11	35	29
AD12/A12	36	30
AD13/A13	37	31
AD14/A14	38	32
AD15/A15	39	33
PC0	40	34
PC1	41	35
PC2	42	36
A19/ $\overline{\text{CSI}}$	43	37
V _{CC}	44	38

**PSD302L
Package
Information**

**Figure 73.
Drawing L4 —
44 Pin Ceramic
Leaded Chip
Carrier (CLDCC)
with Window
(Package Type L)**

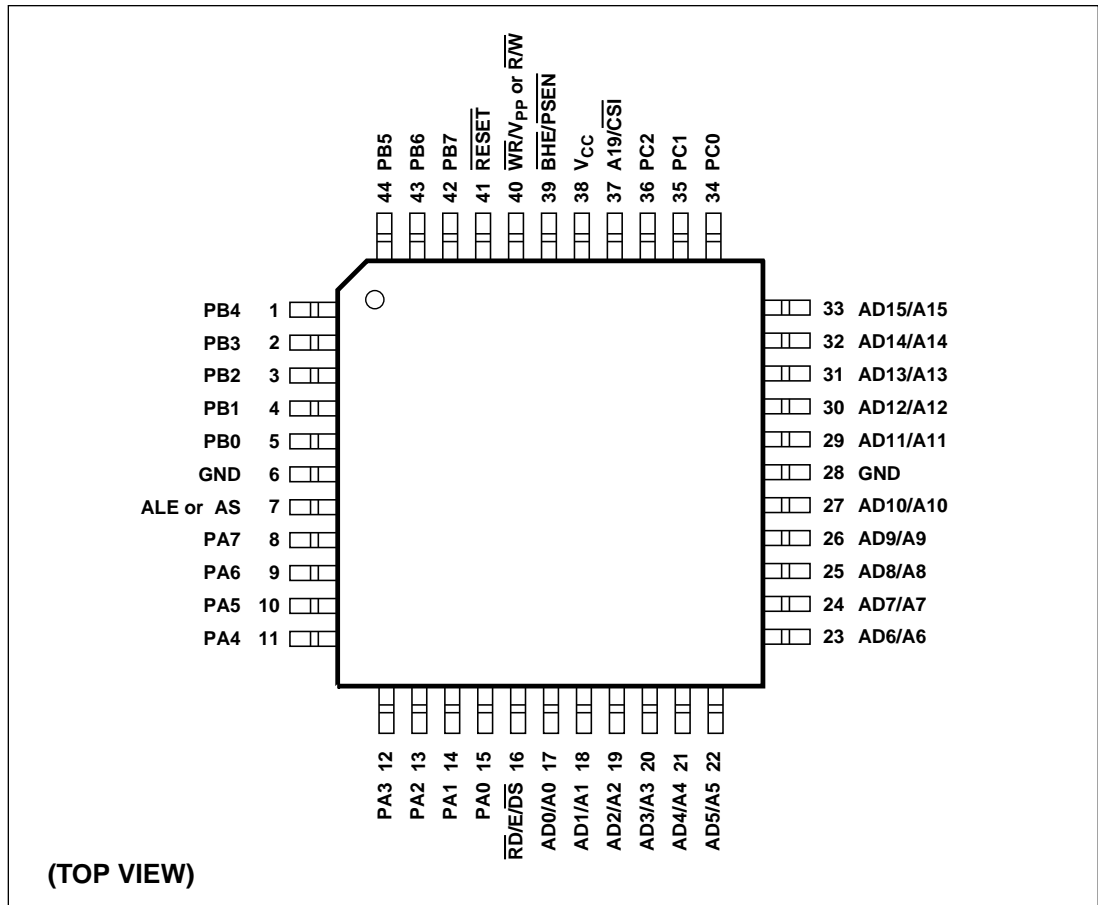


**Figure 74.
Drawing J2 —
44 Pin Plastic
Leaded Chip
Carrier (PLDCC)
(Package Type J)**



**PSD302L
Package
Information**

**Figure 75.
Drawing U1 –
44 Pin
Plastic Thin
Quad Flatpack
(TQFP)
(Package Type U)**





Programmable Peripheral PSD312L 3-Volt Single-Chip Microcontroller Peripheral

Key Features

- Single Chip Programmable Peripheral for Microcontroller-based Applications
- 3.0 to 5.5 Volt Operation
- 19 Individually Configurable I/O pins that can be used as:
 - Microcontroller I/O port expansion
 - Programmable Address Decoder (PAD) I/O
 - Latched address output
 - Open drain or CMOS
- Two Programmable Arrays (PAD A & PAD B)
 - Total of 40 Product Terms and up to 16 Inputs and 24 Outputs
 - Direct Address Decoding up to 1 Meg address space and up to 16 Meg with paging
 - Logic replacement
- “No Glue” Microcontroller Chip-Set
 - Built-in address latches for multiplexed address/data bus
 - Non-multiplexed address/data bus mode
 - 8-bit data bus width
 - ALE polarity programmable
 - Selectable modes for read and write control bus as $\overline{RD}/\overline{WR}$, $R/\overline{W}/E$, or $R/\overline{W}/\overline{DS}$
 - \overline{PSEN} pin for 8051 users
- Built-In Page Logic
 - To Expand the Address Space of Microcontrollers with Limited Address Space Capabilities
 - Up to 16 pages
- 512 Kbits of UV EPROM
 - Configured as 64K x 8
 - Divides into 8 equal mappable blocks for optimized mapping
 - Block resolution is 8K x 8
 - 150 ns EPROM access time, including input latches and PAD address decoding.
- 16 Kbit Static RAM
 - Configured as 2K x 8
 - 150 ns SRAM access time, including input latches and PAD address decoding
- Address/Data Track Mode
 - Enables easy Interface to Shared Resources (e.g., Mail Box SRAM) with other Microcontrollers or a Host Processor
- CMiser-Bit
 - Programmable option to further reduce power consumption
- Built-In Security
 - Locks the PSD312L and PAD Decoding Configuration
- Available in a Choice of Packages
 - 44 Pin PLDCC, CLDCC and TQFP
- Simple Menu-Driven Software:
 - Configure the PSD312L on an IBM PC
- Pin and Functionally Compatible with the PSD3XX and PSD3XXL Series.

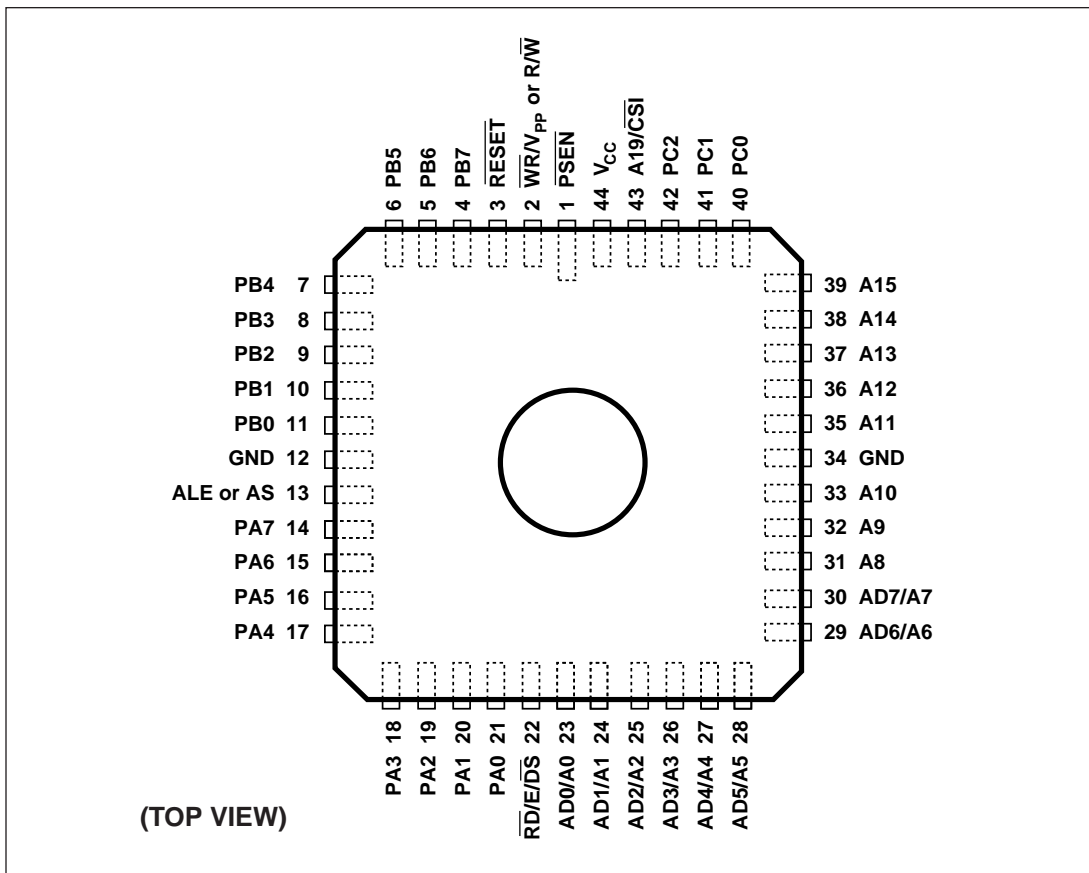
**PSD312L
Pin
Assignments**

<i>Pin Name</i>	<i>44-Pin PLDCC/CLDCC Package</i>	<i>44-Pin TQFP Package</i>
$\overline{\text{PSEN}}$	1	39
$\overline{\text{WR/V}}_{\text{PP}}$ or $\overline{\text{R/W}}$	2	40
$\overline{\text{RESET}}$	3	41
PB7	4	42
PB6	5	43
PB5	6	44
PB4	7	1
PB3	8	2
PB2	9	3
PB1	10	4
PB0	11	5
GND	12	6
ALE or AS	13	7
PA7	14	8
PA6	15	9
PA5	16	10
PA4	17	11
PA3	18	12
PA2	19	13
PA1	20	14
PA0	21	15
$\overline{\text{RD/E/DS}}$	22	16
AD0/A0	23	17
AD1/A1	24	18
AD2/A2	25	19
AD3/A3	26	20
AD4/A4	27	21
AD5/A5	28	22
AD6/A6	29	23
AD7/A7	30	24
A8	31	25
A9	32	26
A10	33	27
GND	34	28
A11	35	29
A12	36	30
A13	37	31
A14	38	32
A15	39	33
PC0	40	34
PC1	41	35
PC2	42	36
A19/ $\overline{\text{CSI}}$	43	37
V _{CC}	44	38

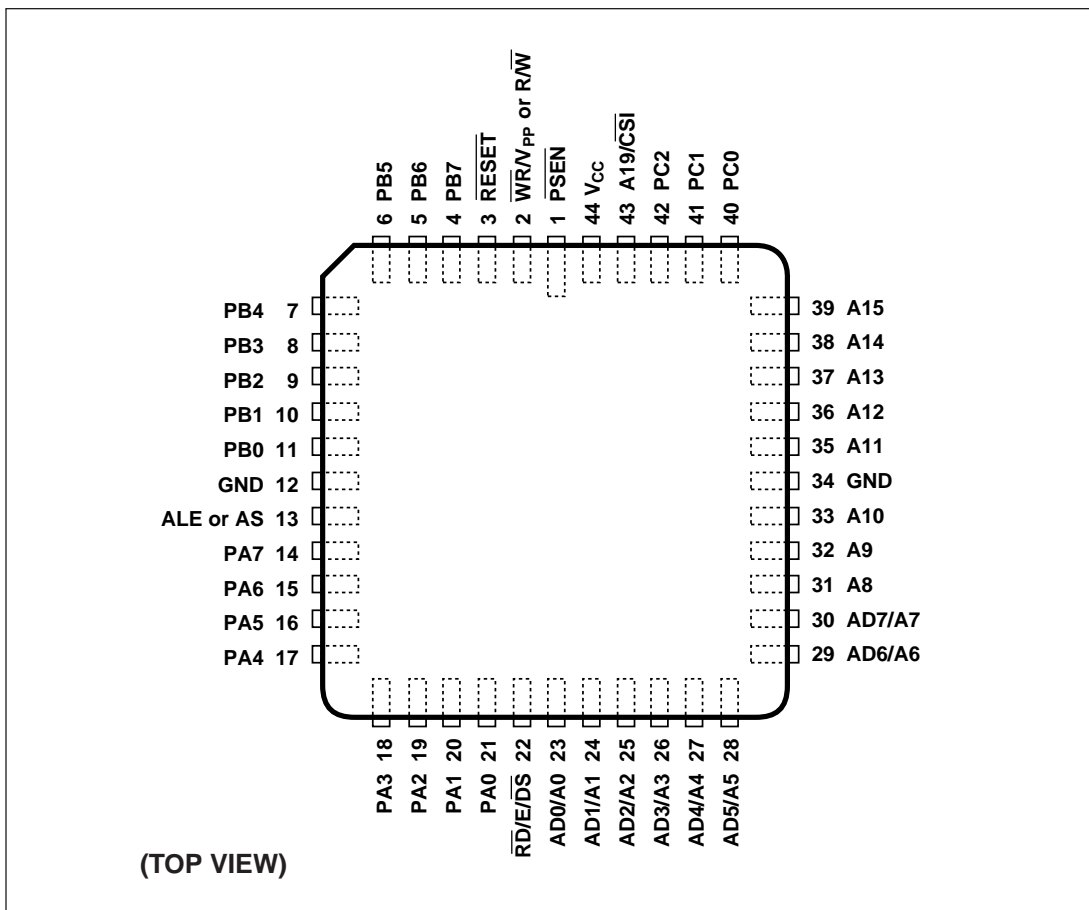


**PSD312L
Package
Information**

**Figure 76.
Drawing L4 —
44 Pin Ceramic
Leaded Chip
Carrier (CLDCC)
with Window
(Package Type L)**

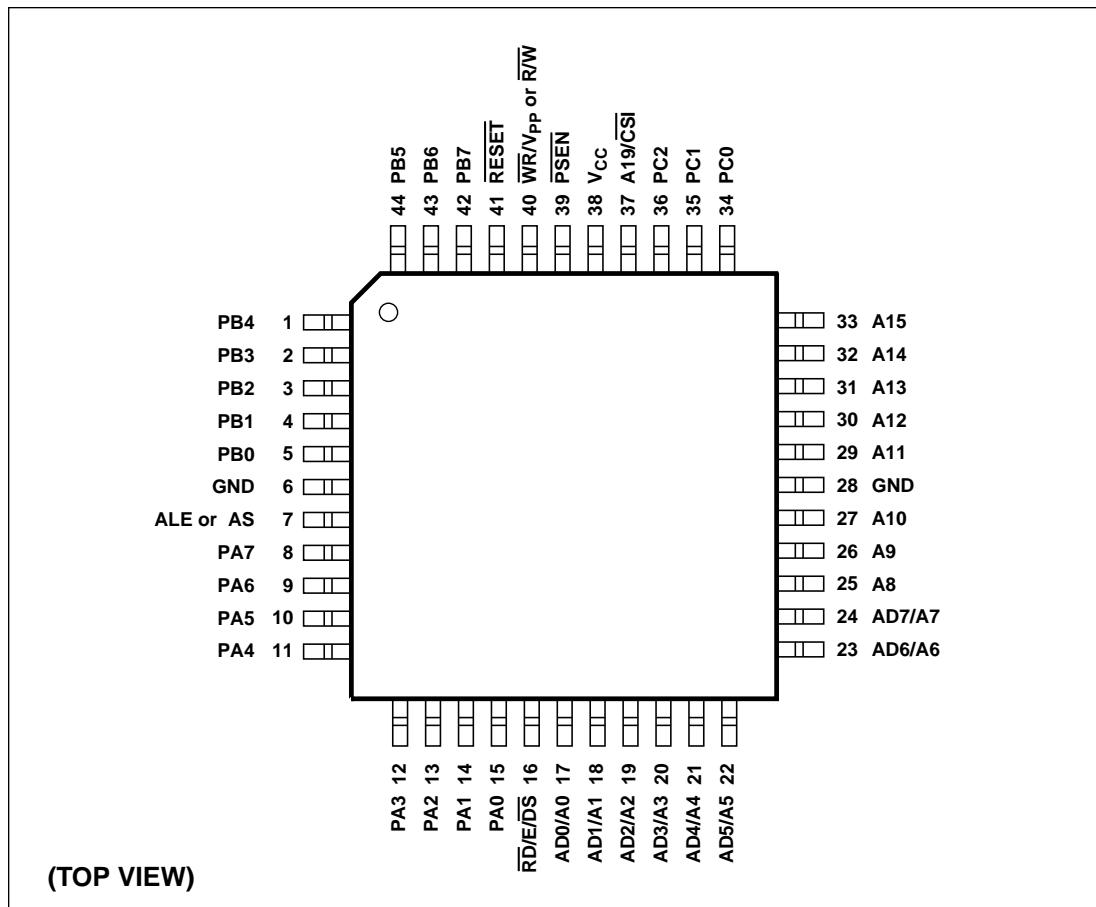


**Figure 77.
Drawing J2 —
44-Pin Plastic
Leaded Chip
Carrier (PLDCC)
(Package Type J)**



PSD312L
Package
Information

Figure 78.
Drawing U1 –
44 Pin
Plastic Thin
Quad Flatpack
(TQFP)
(Package Type U)





Programmable Peripheral PSD303L 3-Volt Single-Chip Microcontroller Peripheral

Key Features

- Single Chip Programmable Peripheral for Microcontroller-based Applications
- 3.0 to 5.5 Volt Operation
- 19 Individually Configurable I/O pins that can be used as:
 - Microcontroller I/O port expansion
 - Programmable Address Decoder (PAD) I/O
 - Latched address output
 - Open drain or CMOS
- Two Programmable Arrays (PAD A & PAD B)
 - Total of 40 Product Terms and up to 16 Inputs and 24 Outputs
 - Direct Address Decoding up to 1 Meg address space and up to 16 Meg with paging
 - Logic replacement
- “No Glue” Microcontroller Chip-Set
 - Built-in address latches for multiplexed address/data bus
 - Non-multiplexed address/data bus mode
 - Selectable 8 or 16 bit data bus width
 - ALE polarity programmable
 - Selectable modes for read and write control bus as $\overline{RD}/\overline{WR}$, $R/\overline{W}/E$, or $R/\overline{W}/\overline{DS}$
 - \overline{BHE} pin for byte select in 16-bit mode
 - \overline{PSEN} pin for 8051 users
- Built-In Page Logic
 - To Expand the Address Space of Microcontrollers with Limited Address Space Capabilities
 - Up to 16 pages
- 1M bit of UV EPROM
 - Configurable as 128K x 8 or as 64K x 16
 - Divides into 8 equal mappable blocks for optimized mapping
 - Block resolution is 16K x 8 or 8K x 16
 - 150 ns EPROM access time, including input latches and PAD address decoding.
- 16 Kbit Static RAM
 - Configurable as 2K x 8 or as 1K x 16
 - 150 ns SRAM access time, including input latches and PAD address decoding
- Address/Data Track Mode
 - Enables easy Interface to Shared Resources (e.g., Mail Box SRAM) with other Microcontrollers or a Host Processor
- CMiser-Bit
 - Programmable option to further reduce power consumption
- Built-In Security
 - Locks the PSD303L and PAD Decoding Configuration
- Available in a Choice of Packages
 - 44 Pin PLDCC, CLDCC and TQFP
- Simple Menu-Driven Software:
 - Configure the PSD303L on an IBM PC
- Pin and Functionally Compatible with the PSD3XX and PSD3XXL Series

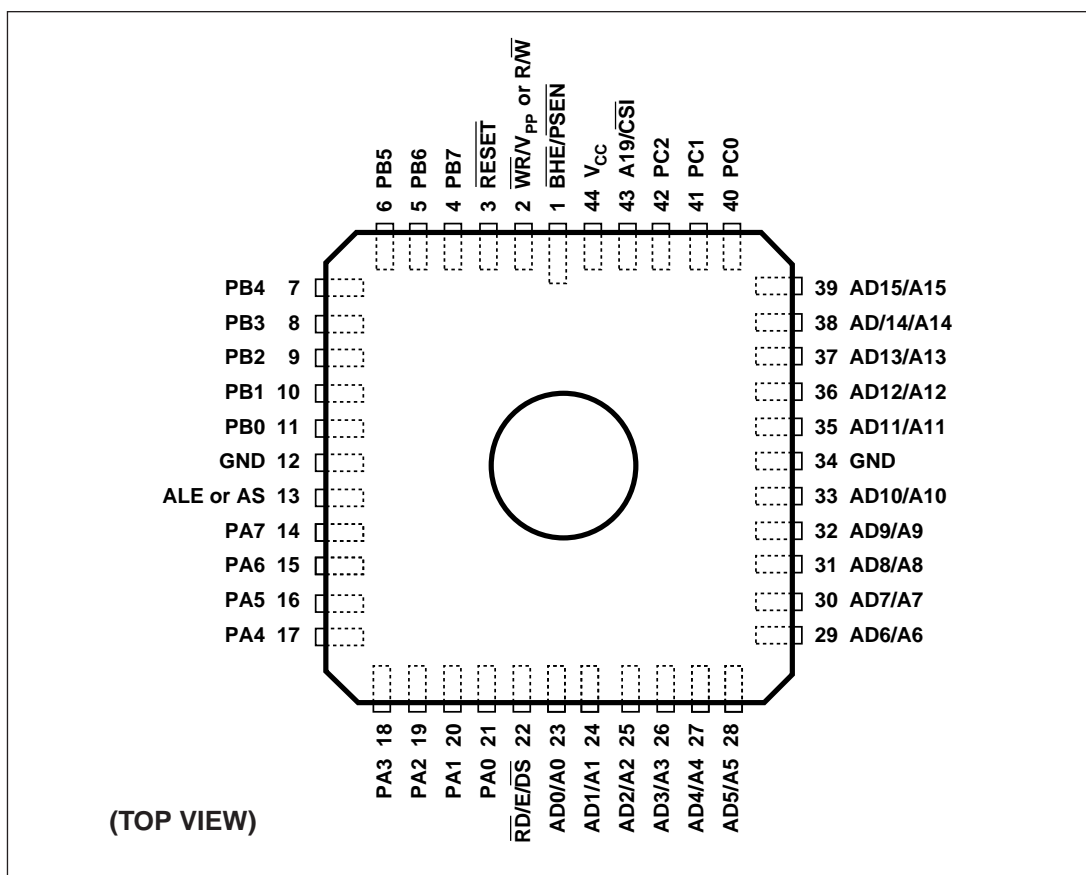
**PSD303L
Pin
Assignments**

<i>Pin Name</i>	<i>44-Pin PLDCC/CLDCC Package</i>	<i>44-Pin TQFP Package</i>
$\overline{\text{BHE}}/\overline{\text{PSEN}}$	1	39
$\overline{\text{WR}}/\overline{\text{V}}_{\text{PP}}$ or $\overline{\text{R}}/\overline{\text{W}}$	2	40
$\overline{\text{RESET}}$	3	41
PB7	4	42
PB6	5	43
PB5	6	44
PB4	7	1
PB3	8	2
PB2	9	3
PB1	10	4
PB0	11	5
GND	12	6
ALE or AS	13	7
PA7	14	8
PA6	15	9
PA5	16	10
PA4	17	11
PA3	18	12
PA2	19	13
PA1	20	14
PA0	21	15
$\overline{\text{RD}}/\text{E}/\text{DS}$	22	16
AD0/A0	23	17
AD1/A1	24	18
AD2/A2	25	19
AD3/A3	26	20
AD4/A4	27	21
AD5/A5	28	22
AD6/A6	29	23
AD7/A7	30	24
AD8/A8	31	25
AD9/A9	32	26
AD10/A10	33	27
GND	34	28
AD11/A11	35	29
AD12/A12	36	30
AD13/A13	37	31
AD14/A14	38	32
AD15/A15	39	33
PC0	40	34
PC1	41	35
PC2	42	36
A19/ $\overline{\text{CSI}}$	43	37
V _{CC}	44	38

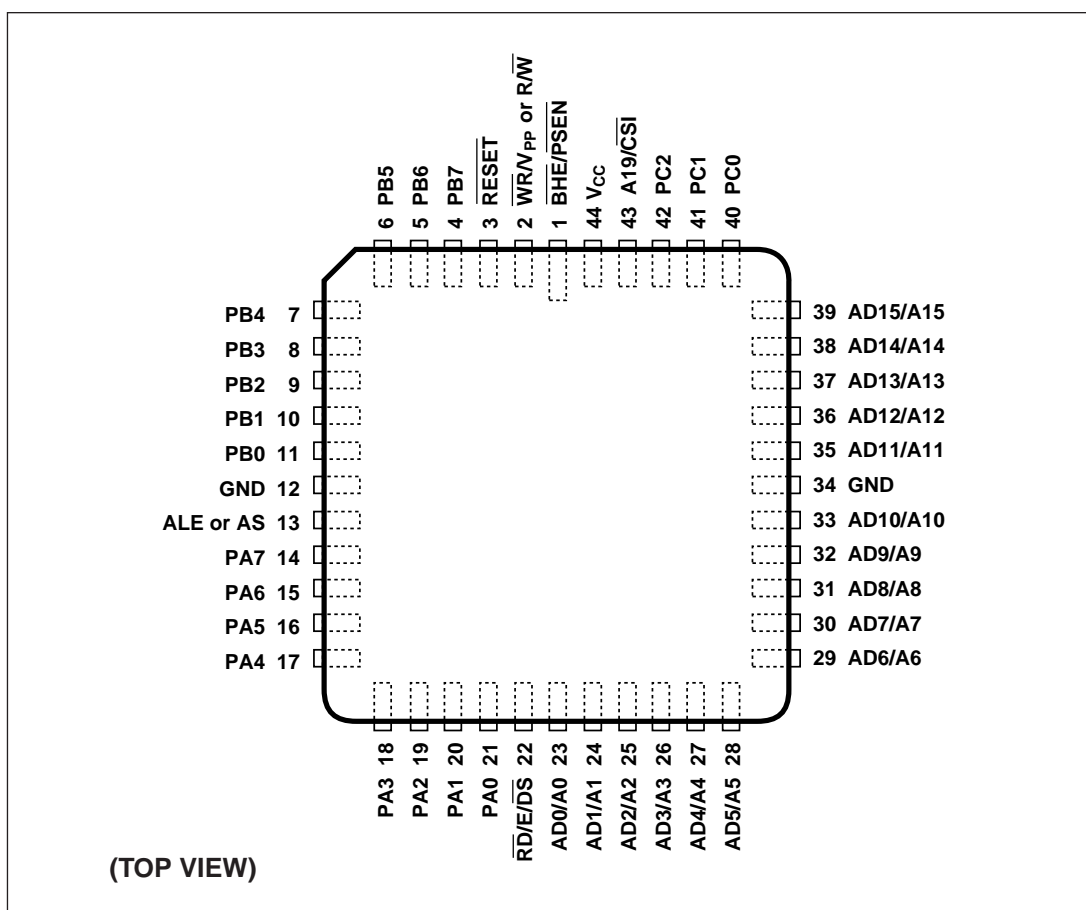


**PSD303L
Package
Information**

**Figure 79.
Drawing L4 —
44 Pin Ceramic
Leaded Chip
Carrier (CLDCC)
with Window
(Package Type L)**

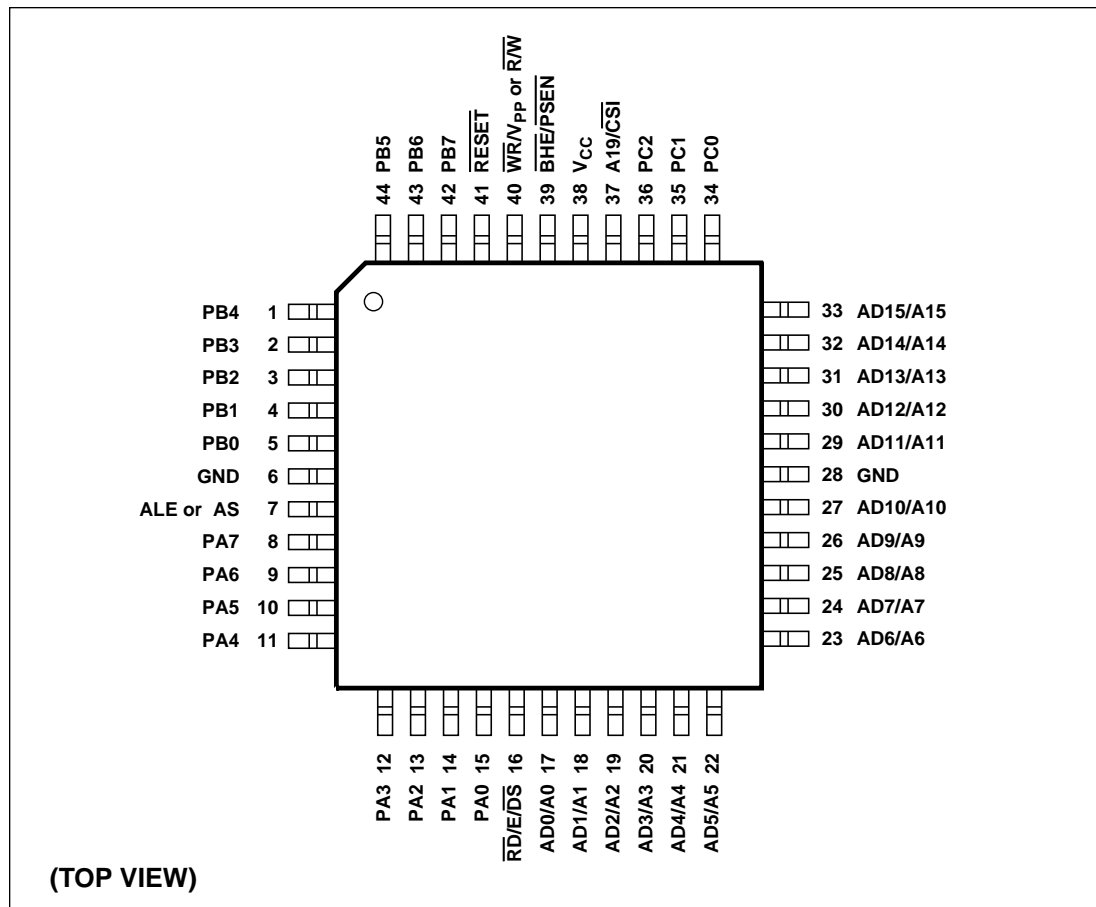


**Figure 80.
Drawing J2 —
44 Pin Plastic
Leaded Chip
Carrier (PLDCC)
(Package Type J)**



PSD303L
Package
Information

Figure 81.
Drawing U1 –
44 Pin
Plastic Thin
Quad Flatpack
(TQFP)
(Package Type U)





Programmable Peripheral PSD313L 3-Volt Single-Chip Microcontroller Peripheral

Key Features

- Single Chip Programmable Peripheral for Microcontroller-based Applications
- 3.0 to 5.5 Volt Operation
- 19 Individually Configurable I/O pins that can be used as:
 - Microcontroller I/O port expansion
 - Programmable Address Decoder (PAD) I/O
 - Latched address output
 - Open drain or CMOS
- Two Programmable Arrays (PAD A & PAD B)
 - Total of 40 Product Terms and up to 16 Inputs and 24 Outputs
 - Direct Address Decoding up to 1 Meg address space and up to 16 Meg with paging
 - Logic replacement
- “No Glue” Microcontroller Chip-Set
 - Built-in address latches for multiplexed address/data bus
 - Non-multiplexed address/data bus mode
 - 8-bit data bus width
 - ALE polarity programmable
 - Selectable modes for read and write control bus as $\overline{RD}/\overline{WR}$, $R/\overline{W}/E$, or $R/\overline{W}/\overline{DS}$
 - \overline{PSEN} pin for 8051 users
- Built-In Page Logic
 - To Expand the Address Space of Microcontrollers with Limited Address Space Capabilities
 - Up to 16 pages
- 1M bit of UV EPROM
 - Configurable as 128K x 8
 - Divides into 8 equal mappable blocks for optimized mapping
 - Block resolution is 16K x 8
 - 150 ns EPROM access time, including input latches and PAD address decoding.
- 16 Kbit Static RAM
 - Configurable as 2K x 8
 - 150 ns SRAM access time, including input latches and PAD address decoding
- Address/Data Track Mode
 - Enables easy Interface to Shared Resources (e.g., Mail Box SRAM) with other Microcontrollers or a Host Processor
- CMiser-Bit
 - Programmable option to further reduce power consumption
- Built-In Security
 - Locks the PSD313L and PAD Decoding Configuration
- Available in a Choice of Packages
 - 44 Pin PLDCC, CLDCC and TQFP
- Simple Menu-Driven Software: Configure the PSD313L on an IBM PC
- Pin and Functionally Compatible with the PSD3XX and PSD3XXL Series

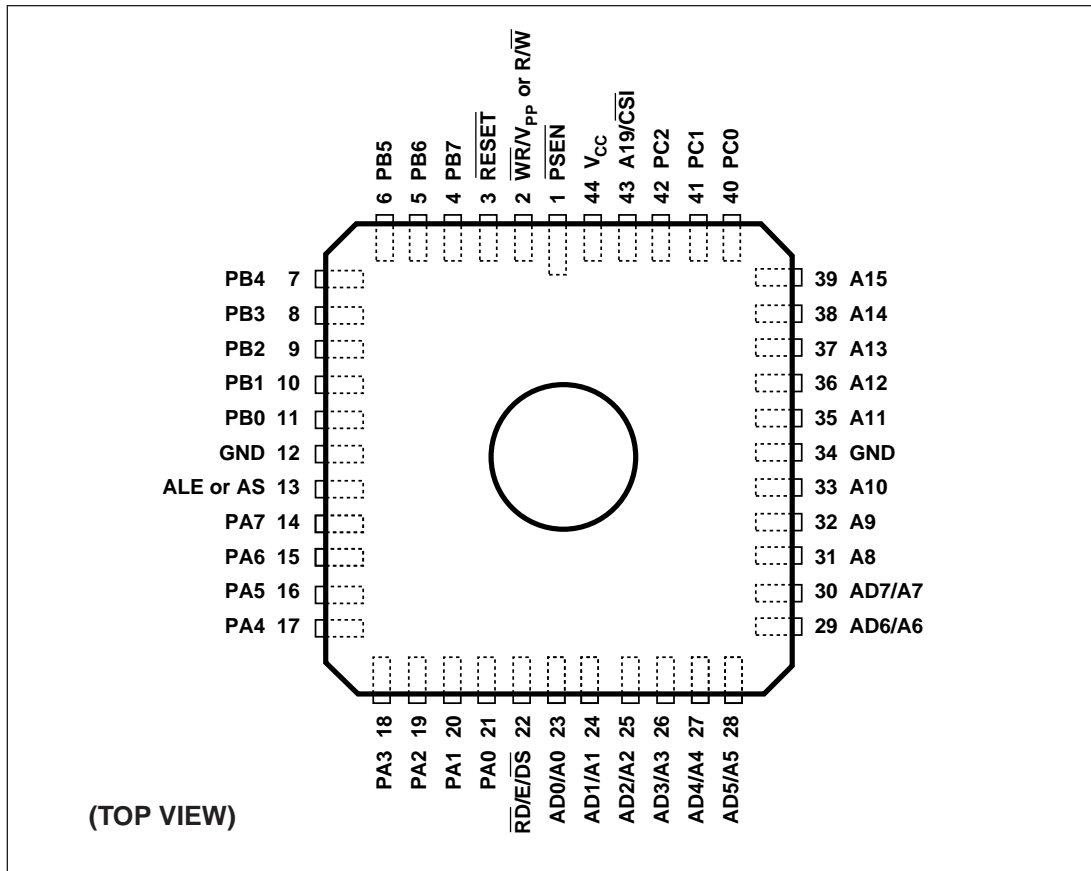
**PSD313L
Pin
Assignments**

<i>Pin Name</i>	<i>44-Pin PLDCC/CLDCC Package</i>	<i>44-Pin TQFP Package</i>
$\overline{\text{PSEN}}$	1	39
$\overline{\text{WR/V}}_{\text{PP}}$ or $\overline{\text{R/W}}$	2	40
$\overline{\text{RESET}}$	3	41
PB7	4	42
PB6	5	43
PB5	6	44
PB4	7	1
PB3	8	2
PB2	9	3
PB1	10	4
PB0	11	5
GND	12	6
ALE or AS	13	7
PA7	14	8
PA6	15	9
PA5	16	10
PA4	17	11
PA3	18	12
PA2	19	13
PA1	20	14
PA0	21	15
$\overline{\text{RD/E/DS}}$	22	16
AD0/A0	23	17
AD1/A1	24	18
AD2/A2	25	19
AD3/A3	26	20
AD4/A4	27	21
AD5/A5	28	22
AD6/A6	29	23
AD7/A7	30	24
A8	31	25
A9	32	26
A10	33	27
GND	34	28
A11	35	29
A12	36	30
A13	37	31
A14	38	32
A15	39	33
PC0	40	34
PC1	41	35
PC2	42	36
A19/ $\overline{\text{CSI}}$	43	37
V _{CC}	44	38

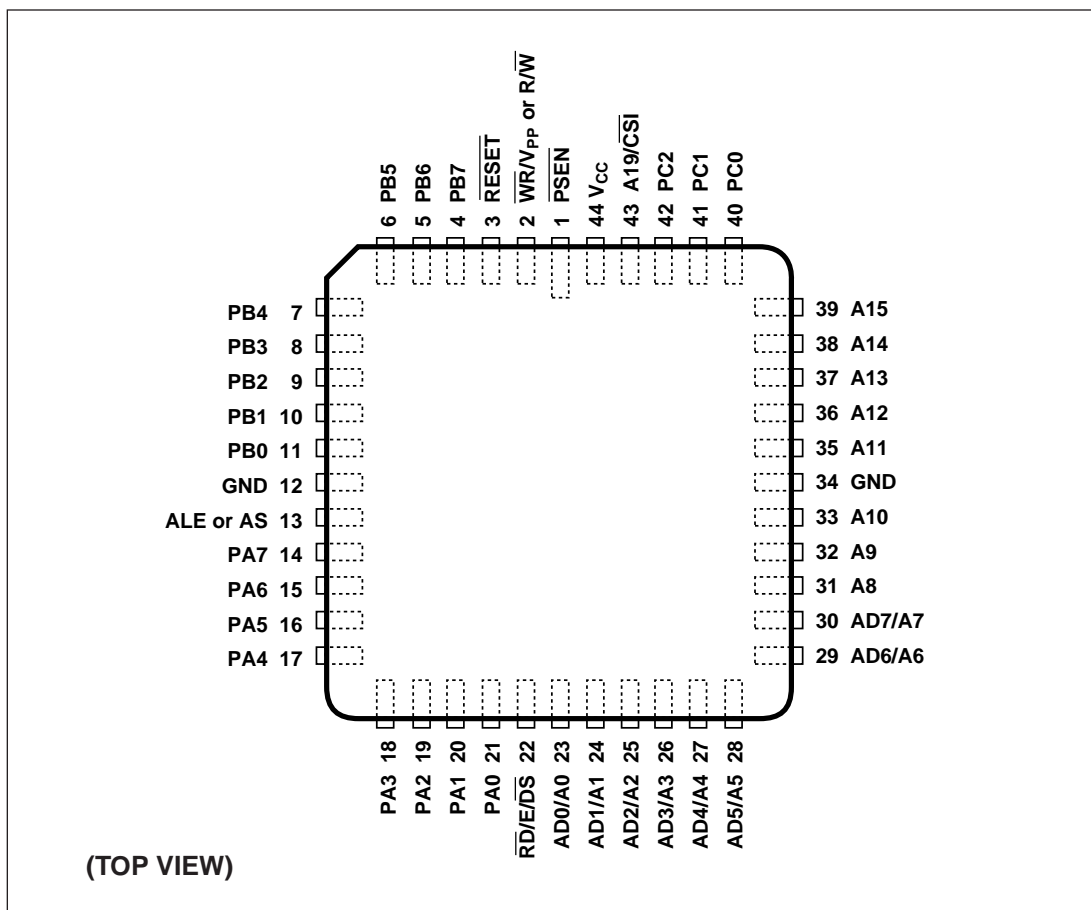


**PSD313L
Package
Information**

**Figure 82.
Drawing L4 —
44 Pin Ceramic
Leaded Chip
Carrier (CLDCC)
with Window
(Package Type L)**

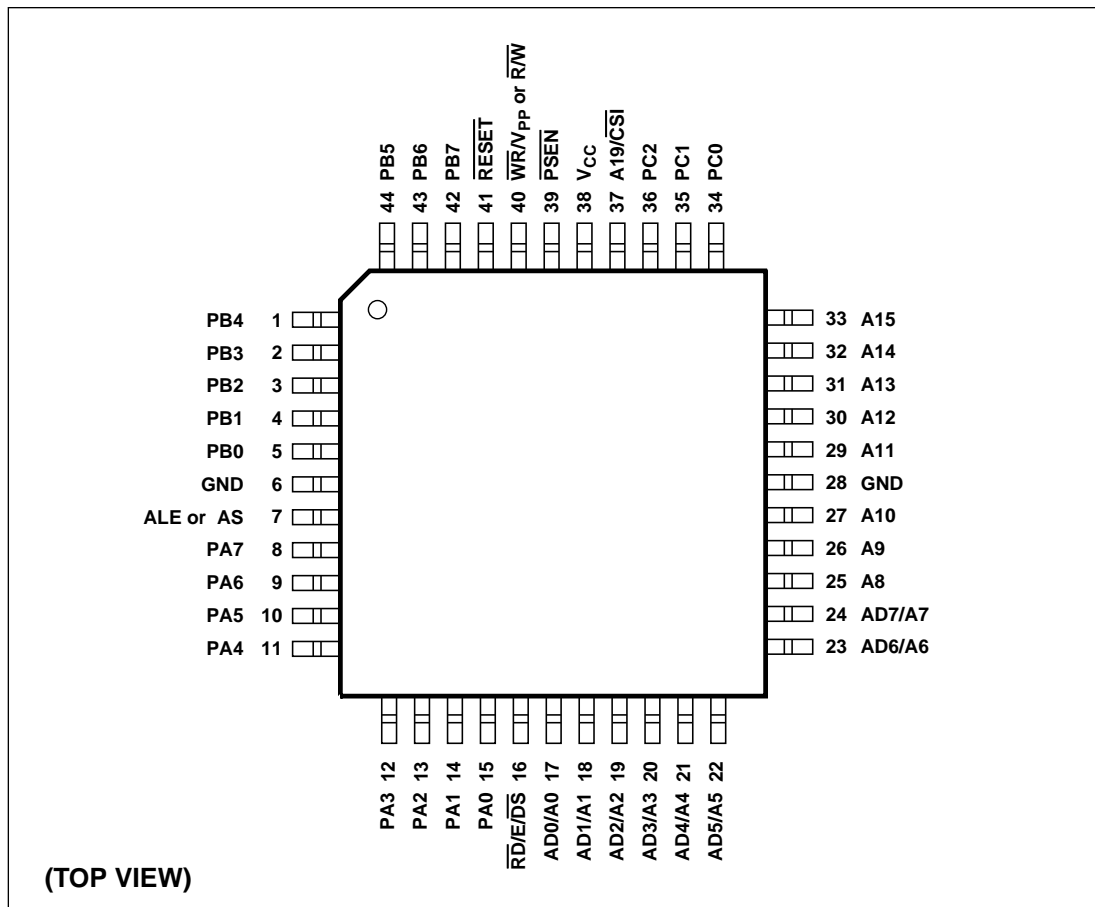


**Figure 83.
Drawing J2 —
44-Pin Plastic
Leaded Chip
Carrier (PLDCC)
(Package Type J)**



PSD313L
Package
Information

Figure 84.
Drawing U1 –
44 Pin
Plastic Thin
Quad Flatpack
(TQFP)
(Package Type U)





Programmable Peripheral PSD304RL 3-Volt Single-Chip Microcontroller Peripheral

Key Features

- Single Chip Programmable Peripheral for Microcontroller-based Applications
- 3.0 to 5.5 Volt Operation
- 19 Individually Configurable I/O pins that can be used as:
 - Microcontroller I/O port expansion
 - Programmable Address Decoder (PAD) I/O
 - Latched address output
 - Open drain or CMOS
- Two Programmable Arrays (PAD A & PAD B)
 - Total of 40 Product Terms and up to 16 Inputs and 24 Outputs
 - Direct Address Decoding up to 1 Meg address space and up to 16 Meg with paging
 - Logic replacement
- “No Glue” Microcontroller Chip-Set
 - Built-in address latches for multiplexed address/data bus
 - Non-multiplexed address/data bus mode
 - Selectable 8 or 16 bit data bus width
 - ALE polarity programmable
 - Selectable modes for read and write control bus as $\overline{RD}/\overline{WR}$, $R/\overline{W}/E$, or $R/\overline{W}/\overline{DS}$
 - \overline{BHE} pin for byte select in 16-bit mode
 - \overline{PSEN} pin for 8051 users
- Built-In Page Logic
 - To Expand the Address Space of Microcontrollers with Limited Address Space Capabilities
 - Up to 16 pages
- 2M bit of UV EPROM
 - Configurable as 256K x 8 or as 128K x 16
 - Divides into 8 equal mappable blocks for optimized mapping
 - Block resolution is 32K x 8 or 16K x 16
 - 300 ns EPROM access time, including input latches and PAD address decoding.
- Address/Data Track Mode
 - Enables easy Interface to Shared Resources (e.g., Mail Box SRAM) with other Microcontrollers or a Host Processor
- CMiser-Bit
 - Programmable option to further reduce power consumption
- Built-In Security
 - Locks the PSD304RL and PAD Decoding Configuration
- Available in a Choice of Packages
 - 44 Pin PLDCC, CLDCC and TQFP
- Simple Menu-Driven Software:
 - Configure the PSD304RL on an IBM PC
- Pin and Functionally Compatible with the PSD3XX and PSD3XXL Series

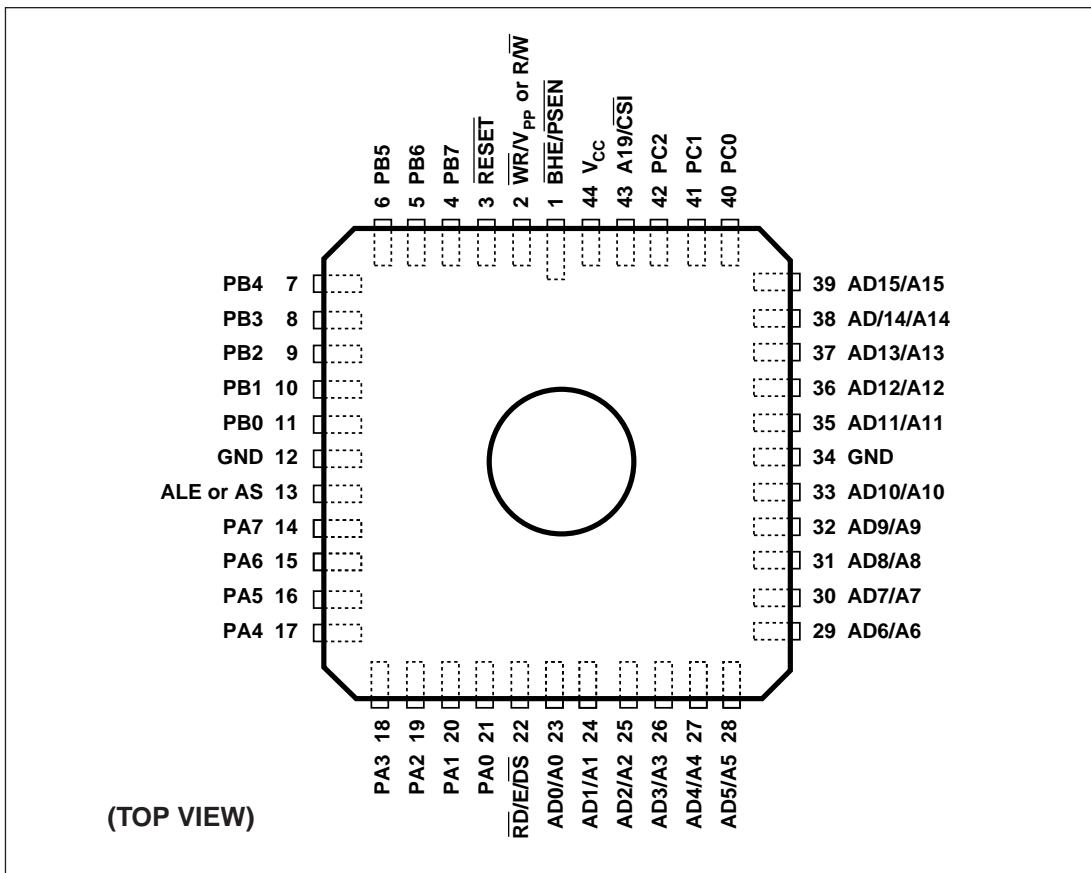
**PSD304RL
Pin
Assignments**

<i>Pin Name</i>	<i>44-Pin PLDCC/CLDCC Package</i>	<i>44-Pin TQFP Package</i>
$\overline{\text{BHE}}/\overline{\text{PSEN}}$	1	39
$\overline{\text{WR}}/\overline{\text{V}}_{\text{PP}}$ or $\overline{\text{R}}/\overline{\text{W}}$	2	40
$\overline{\text{RESET}}$	3	41
PB7	4	42
PB6	5	43
PB5	6	44
PB4	7	1
PB3	8	2
PB2	9	3
PB1	10	4
PB0	11	5
GND	12	6
ALE or AS	13	7
PA7	14	8
PA6	15	9
PA5	16	10
PA4	17	11
PA3	18	12
PA2	19	13
PA1	20	14
PA0	21	15
$\overline{\text{RD}}/\text{E}/\text{DS}$	22	16
AD0/A0	23	17
AD1/A1	24	18
AD2/A2	25	19
AD3/A3	26	20
AD4/A4	27	21
AD5/A5	28	22
AD6/A6	29	23
AD7/A7	30	24
AD8/A8	31	25
AD9/A9	32	26
AD10/A10	33	27
GND	34	28
AD11/A11	35	29
AD12/A12	36	30
AD13/A13	37	31
AD14/A14	38	32
AD15/A15	39	33
PC0	40	34
PC1	41	35
PC2	42	36
A19/ $\overline{\text{CSI}}$	43	37
V _{CC}	44	38

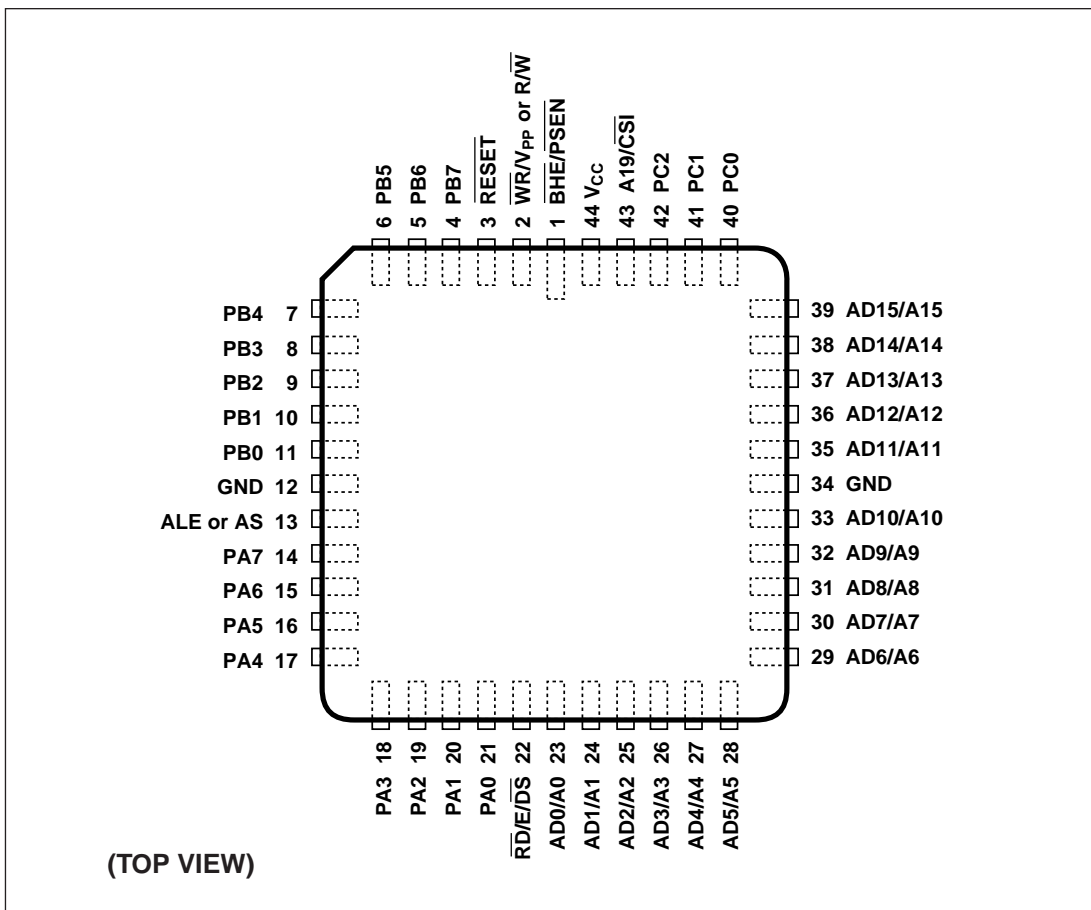


**PSD304RL
Package
Information**

**Figure 85.
Drawing L4 —
44 Pin Ceramic
Leaded Chip
Carrier (CLDCC)
with Window
(Package Type L)**

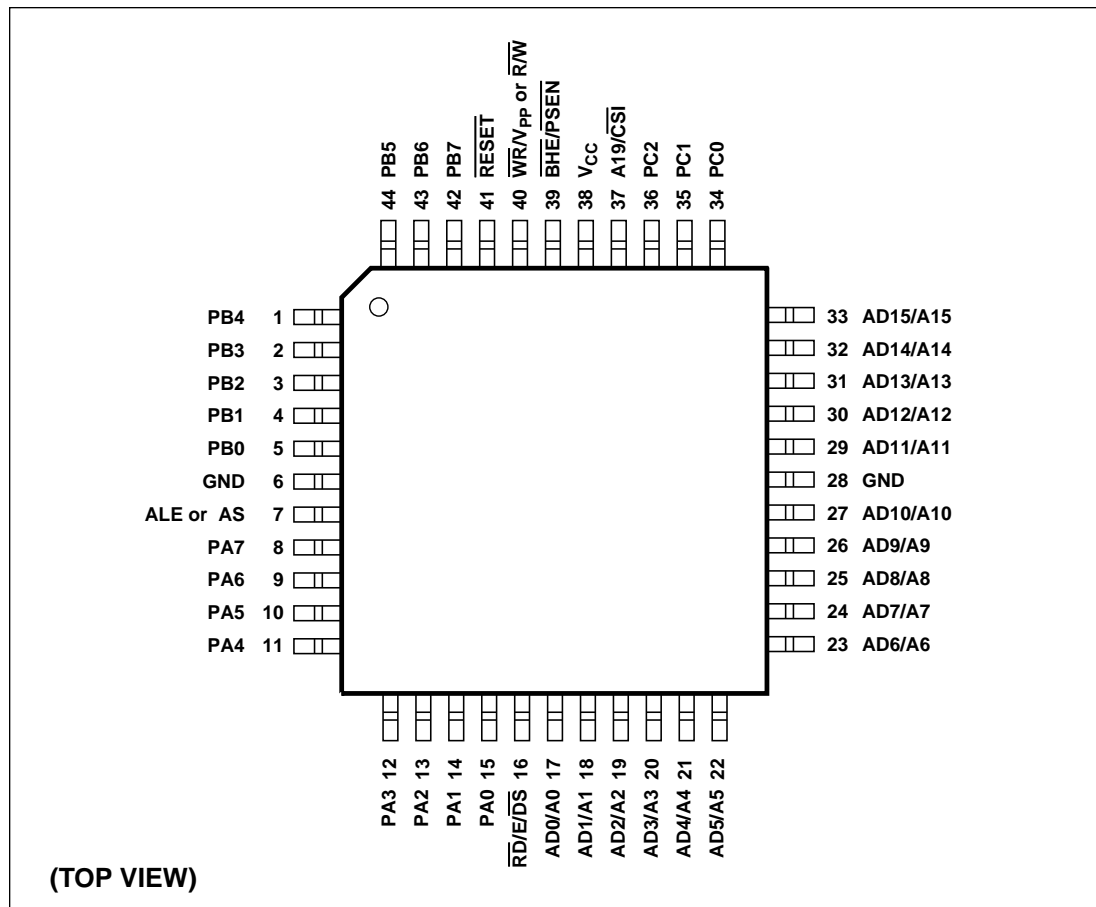


**Figure 86.
Drawing J2 —
44 Pin Plastic
Leaded Chip
Carrier (PLDCC)
(Package Type J)**



PSD304RL
Package
Information

Figure 87.
Drawing U1 –
44 Pin
Plastic Thin
Quad Flatpack
(TQFP)
(Package Type U)





Programmable Peripheral PSD314RL 3-Volt Single-Chip Microcontroller Peripheral

Key Features

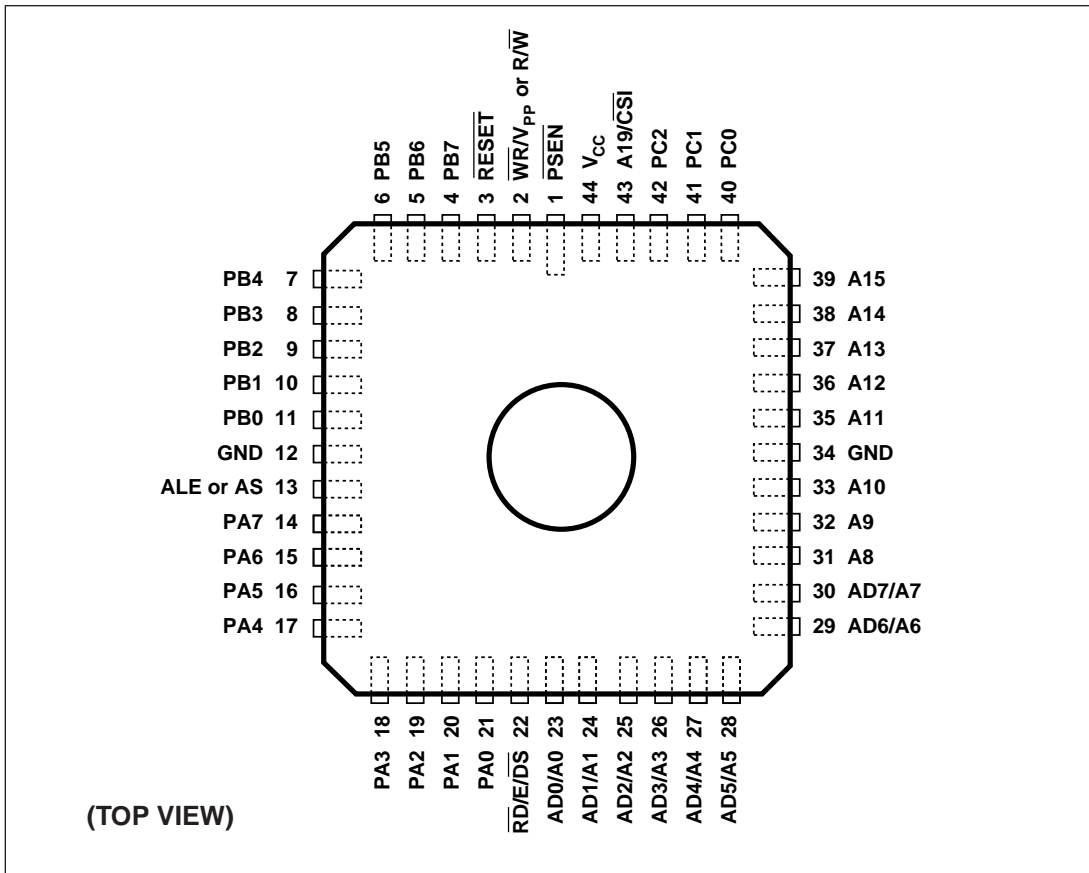
- Single Chip Programmable Peripheral for Microcontroller-based Applications
- 3.0 to 5.5 Volt Operation
- 19 Individually Configurable I/O pins that can be used as:
 - Microcontroller I/O port expansion
 - Programmable Address Decoder (PAD) I/O
 - Latched address output
 - Open drain or CMOS
- Two Programmable Arrays (PAD A & PAD B)
 - Total of 40 Product Terms and up to 16 Inputs and 24 Outputs
 - Direct Address Decoding up to 1 Meg address space and up to 16 Meg with paging
 - Logic replacement
- “No Glue” Microcontroller Chip-Set
 - Built-in address latches for multiplexed address/data bus
 - Non-multiplexed address/data bus mode
 - 8-bit data bus width
 - ALE polarity programmable
 - Selectable modes for read and write control bus as $\overline{RD}/\overline{WR}$, $R/\overline{W}/E$, or $R/\overline{W}/\overline{DS}$
 - \overline{PSEN} pin for 8051 users
- Built-In Page Logic
 - To Expand the Address Space of Microcontrollers with Limited Address Space Capabilities
 - Up to 16 pages
- 2M bit of UV EPROM
 - Configurable as 256K x 8
 - Divides into 8 equal mappable blocks for optimized mapping
 - Block resolution is 32K x 8
 - 300 ns EPROM access time, including input latches and PAD address decoding.
- Address/Data Track Mode
 - Enables easy Interface to Shared Resources (e.g., Mail Box SRAM) with other Microcontrollers or a Host Processor
- CMiser-Bit
 - Programmable option to further reduce power consumption
- Built-In Security
 - Locks the PSD314RL and PAD Decoding Configuration
- Available in a Choice of Packages
 - 44 Pin PLDCC, CLDCC and TQFP
- Simple Menu-Driven Software: Configure the PSD314RL on an IBM PC
- Pin and Functionally Compatible with the PSD3XX and PSD3XXL Series

**PSD314RL
Pin
Assignments**

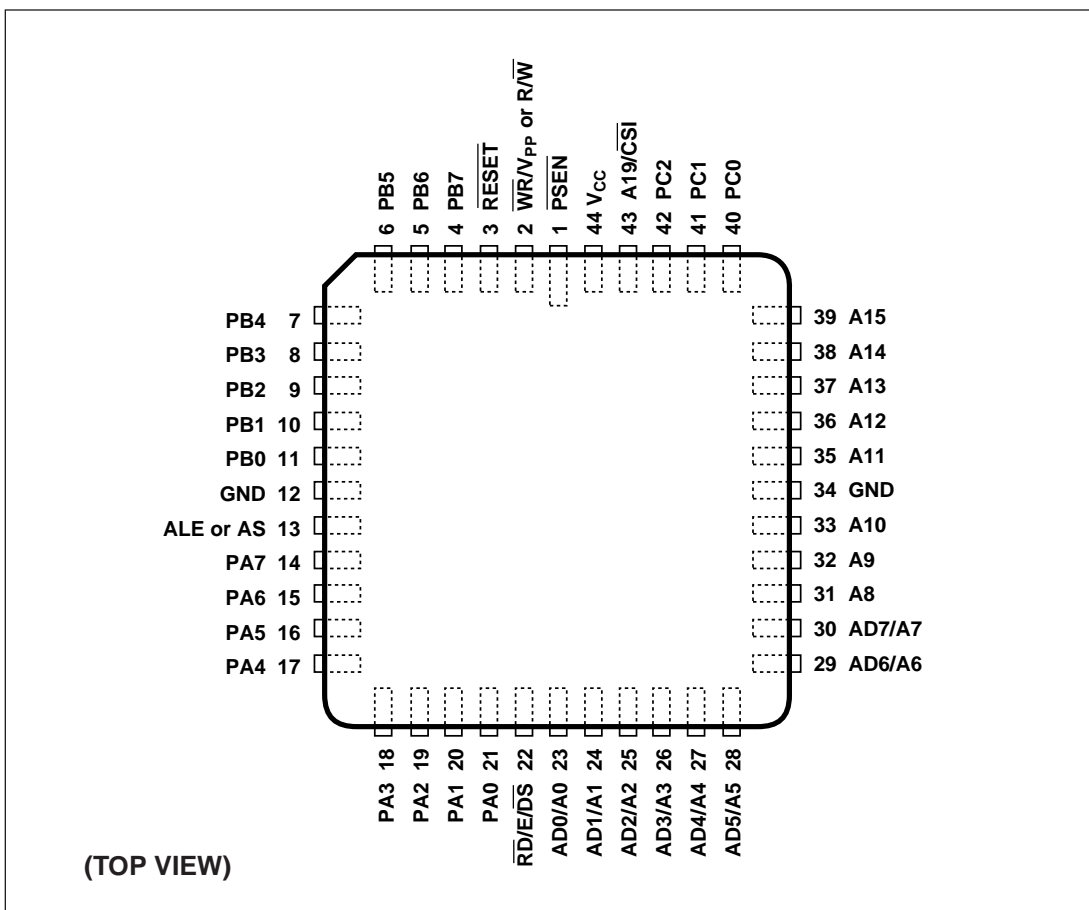
<i>Pin Name</i>	<i>44-Pin PLDCC/CLDCC Package</i>	<i>44-Pin TQFP Package</i>
$\overline{\text{PSEN}}$	1	39
$\overline{\text{WR/V}}_{\text{PP}}$ or $\overline{\text{R/W}}$	2	40
$\overline{\text{RESET}}$	3	41
PB7	4	42
PB6	5	43
PB5	6	44
PB4	7	1
PB3	8	2
PB2	9	3
PB1	10	4
PB0	11	5
GND	12	6
ALE or AS	13	7
PA7	14	8
PA6	15	9
PA5	16	10
PA4	17	11
PA3	18	12
PA2	19	13
PA1	20	14
PA0	21	15
$\overline{\text{RD/E/DS}}$	22	16
AD0/A0	23	17
AD1/A1	24	18
AD2/A2	25	19
AD3/A3	26	20
AD4/A4	27	21
AD5/A5	28	22
AD6/A6	29	23
AD7/A7	30	24
A8	31	25
A9	32	26
A10	33	27
GND	34	28
A11	35	29
A12	36	30
A13	37	31
A14	38	32
A15	39	33
PC0	40	34
PC1	41	35
PC2	42	36
A19/ $\overline{\text{CSI}}$	43	37
V _{CC}	44	38

**PSD314RL
Package
Information**

**Figure 88.
Drawing L4 —
44 Pin Ceramic
Leaded Chip
Carrier (CLDCC)
with Window
(Package Type L)**

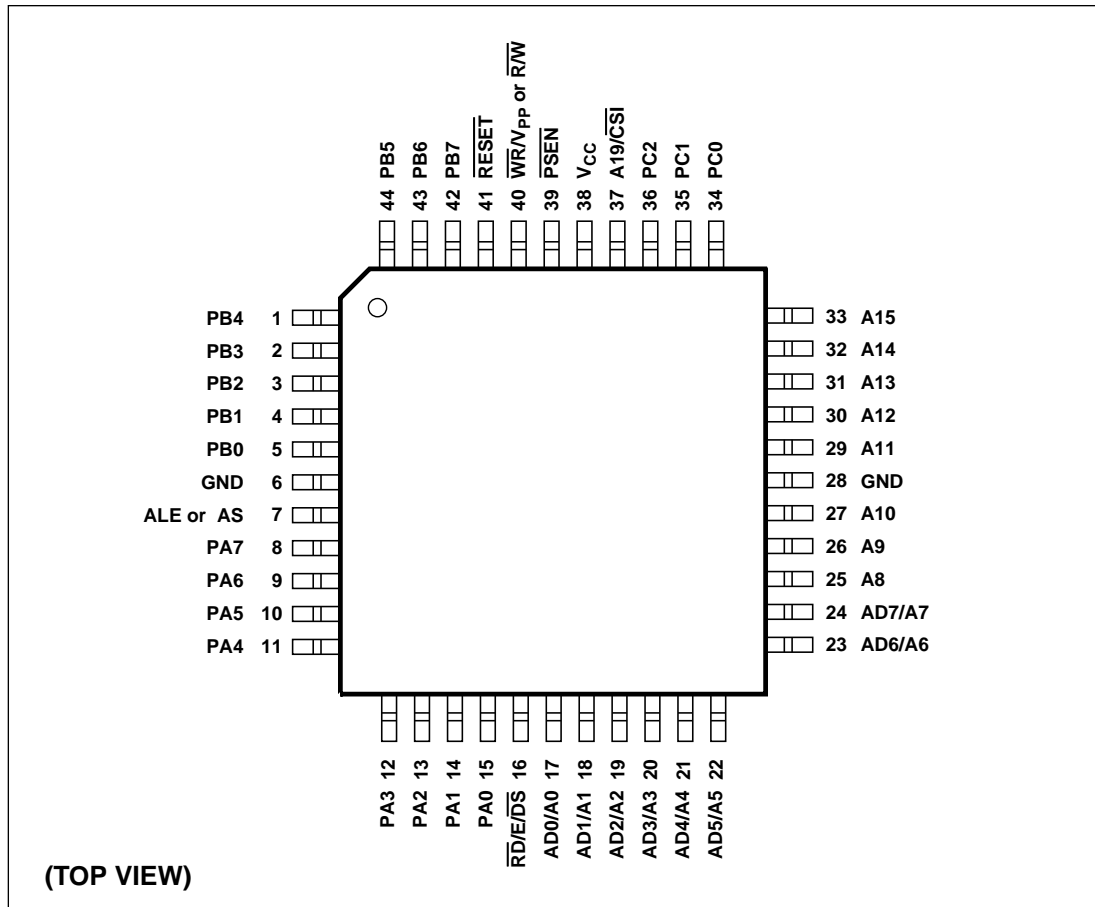


**Figure 89.
Drawing J2 —
44-Pin Plastic
Leaded Chip
Carrier (PLDCC)
(Package Type J)**



**PSD314RL
Package
Information**

**Figure 90.
Drawing U1 –
44 Pin
Plastic Thin
Quad Flatpack
(TQFP)
(Package Type U)**



**PSD3XX Product
Ordering
Information**

PSD3XX family devices are available in a wide range of product selections. Options and combinations include:

- Architecture
- Speed (Access Time)
- Memory Size
- Configuration
- SRAM/no SRAM
- Mask Programmability
- Operating Temperature Range
- Supply Voltages
- Packages

Please contact your local WSI Sales Representative or Distributor for the PSD3XX product selection that best fits your application and objectives.

