



**SF2042C**

**456.00 MHz  
SAW Filter**

- *Designed for 802.16 and WIMAX Receiver IF Application*
- *Low Insertion Loss*
- *5.0 X 5.0 mm Surface-mount Case*
- *Differential Input and Output*
- *Complies with Directive 2002/95/EC (RoHS)*



**Absolute Maximum Ratings**

Rating	Value	Units
Maximum Incident Power in Passband	+13	dBm
Maximum DC Voltage on any Non-ground Terminal	30	VDC
Storage Temperature Range	-40 to +85	°C
Suitable for Lead-free Soldering - Maximum Soldering Profile	260°C for 30 s	

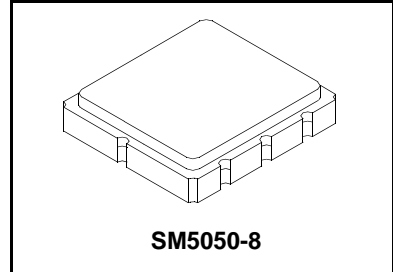

**Electrical Characteristics**

Characteristic	Sym	Notes	Min	Typ	Max	Units
Nominal Center Frequency	CF	1, 10		456.00		MHz
Insertion Loss @ 25°C				12	14	dB
Differential Impedance line-to-line				200		ohms
1 dB Bandwidth	BW <sub>1</sub>	10	±6.4	±8		MHz
3 dB Bandwidth	BW <sub>3</sub>	10	±7.5	±9		
Group Delay Variation, CF ±6.4 MHz				20	150	ns <sub>p-p</sub>
Return Loss			8	15		dB
Rejection Referenced to 0 dB:						dB
DC to 256 MHz			40	55		
256 to 360 MHz			40	60		
360 to 416 MHz			40	50		
416 to 443 MHz			32	40		
470 to 656 MHz			35	40		
656 to 946 MHz			35	60		
Equivalent Input Circuit				250 ohm   4.8 pF		
Equivalent Output Circuit				220 ohm   5.2 pF		
Frequency Temperature Coefficient		10		-15		kHz/°C
Operating Temperature Range			-40		85	°C
Storage Temperature Range in Tape and Reel			-40		85	
Case Style			SM5050-8 5 x 5 mm Nominal Footprint			
Lid Symbolization (YY=year, WW=week, S=shift)			RFM 557 YYWWS			



**CAUTION: Electrostatic Sensitive Device. Observe precautions for handling.**

**Notes:**

1. Unless noted otherwise, all specifications apply over the operating temperature range with filter soldered to the specified demonstration board with impedance matching to 50 Ω and measured with 50 Ω network analyzer.
2. Rejection is measured as attenuation below the minimum IL point in the passband. Rejection in final user application is dependent on PCB layout and external impedance matching design. See Application Note No. 42 for details.
3. The design, manufacturing process, and specifications of this filter are subject to change.
4. Tape and Reel Standard ANSI / EIA 481.
5. Either Port 1 or Port 2 may be used for either input or output in the design. However, impedances and impedance matching may vary between Port 1 and Port 2, so that the filter must always be installed in one direction per the circuit design.
6. US and international patents may apply.
7. RFM, stylized RFM logo, and RF Monolithics, Inc. are registered trademarks of RF Monolithics, Inc.
8. The center of the bandwidths will move with ambient temperature.

# SM5050-8 Case

## 8-Terminal Ceramic Surface-Mount Case 5.0 X 5.0 mm Nominal Footprint

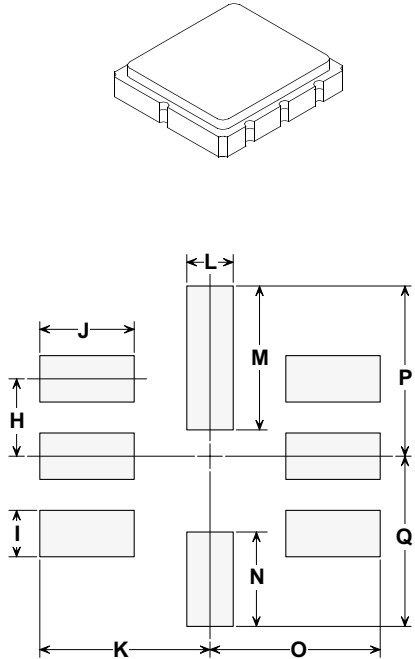

PCB Footprint

### Case Dimensions

Dimension	mm			Inches		
	Min	Nom	Max	Min	Nom	Max
A	4.80	5.00	5.20	0.189	0.197	0.205
B	4.80	5.00	5.20	0.189	0.197	0.205
C	1.30	1.50	1.70	0.050	0.060	0.067
D	1.98	2.08	2.18	0.078	0.082	0.086
E	1.07	1.17	1.27	0.042	0.046	0.050
F	0.50	0.64	0.70	0.020	0.025	0.028
G	2.39	2.54	2.69	0.094	0.100	0.106
H		1.27			0.050	
I		0.76			0.030	
J		1.55			0.061	
K		2.79			0.110	
L		0.76			0.030	
M		2.36			0.093	
N		1.55			0.061	
O		2.79			0.110	
P		2.79			0.110	
Q		2.79			0.110	

### Case Materials

Materials	
Solder Pad Plating	0.3 to 1.0 $\mu\text{m}$ Gold over 1.27 to 8.89 $\mu\text{m}$ Nickel
Lid Plating	2.0 to 3.0 $\mu\text{m}$ Nickel
Body	$\text{Al}_2\text{O}_3$ Ceramic
	Pb Free

### TOP VIEW

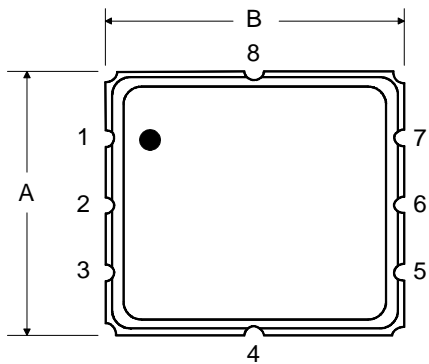

### BOTTOM VIEW

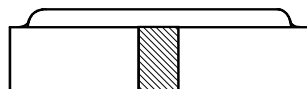
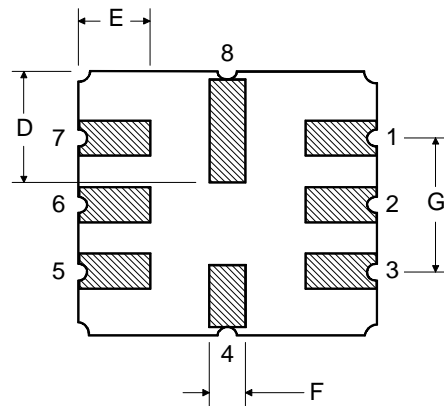

## Tape and Reel Specifications

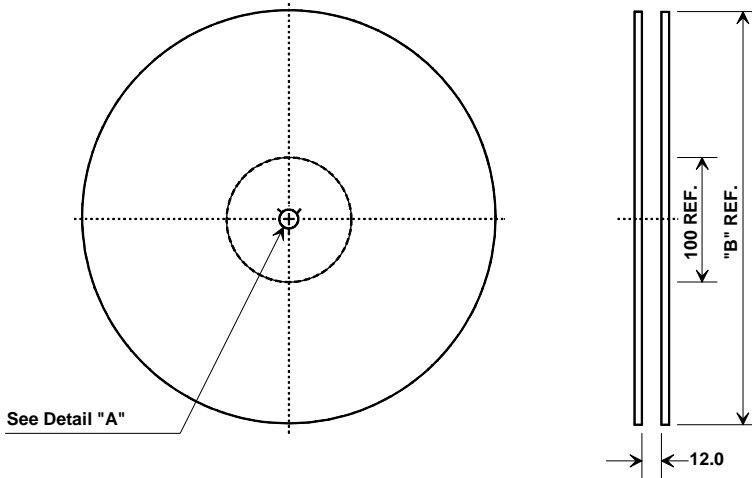

"B" Nominal Size		Quantity Per Reel
Inches	millimeters	
7	178	500
13	330	3000

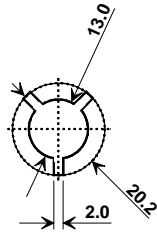

### COMPONENT ORIENTATION and DIMENSIONS

Carrier Tape Dimensions	
Ao	5.3 mm
Bo	5.3 mm
Ko	2.0 mm
Pitch	8.0 mm
W	12.0 mm

COVER TAPE SIZE

