

Feature

1. Small SMD package. (3.0 x 3.0 x 1.15[max.])
2. As they apply fundamental oscillation, oscillator using SAW resonator is stable.
3. They can be applied CORPITTS OSCILLATOR circuit.
4. Product lead free.

Specification

Item	Specification (25±2°C)	Item	Specification
Resonant Frequency		Operating Temperature Range	-40 to +85°C
SARCC433M87BXL0	433.870 MHz ± 0.050 MHz	Storage Temperature Range	-40 to +85°C
SARCC433M87BXM0	433.870 MHz ± 0.075 MHz	D. C. Voltage between the terminals	3V (max.)
SARCC433M87BXP0	433.870 MHz ± 0.100 MHz	Turnover Temperature	25°C typ.
Resonant Loss	2.5 dB max.	Frequency Temperature Coefficient	-0.03 ppm/°C ² typ.
Parallel Capacitance at 1MHz	2.1±0.5 pF	Frequency Aging	±10 ppm/yr typ.

Package Dimensions

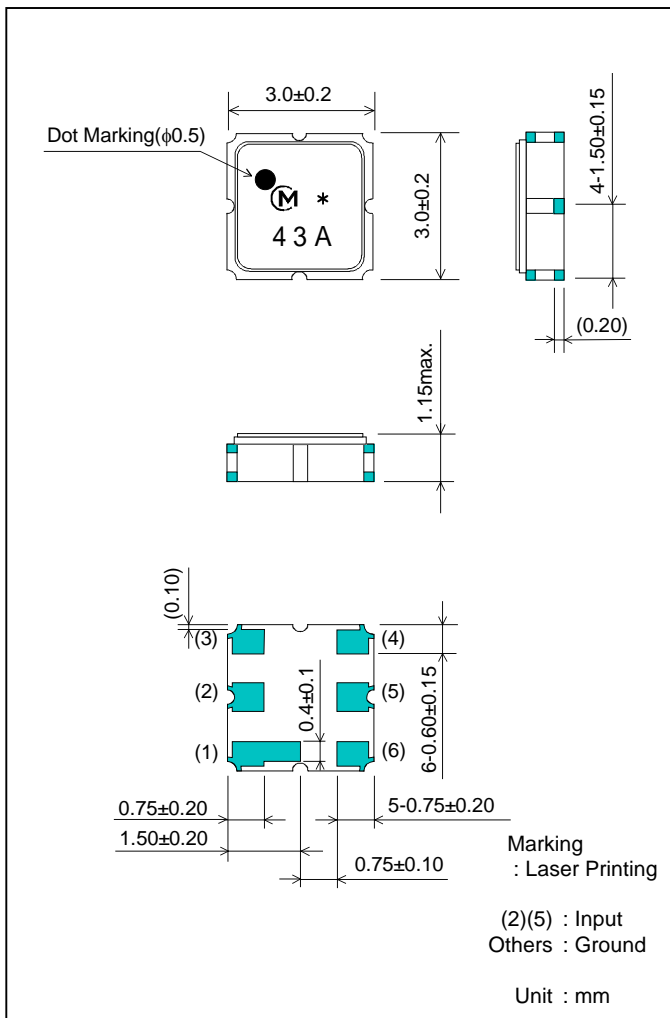

Equivalent Circuit

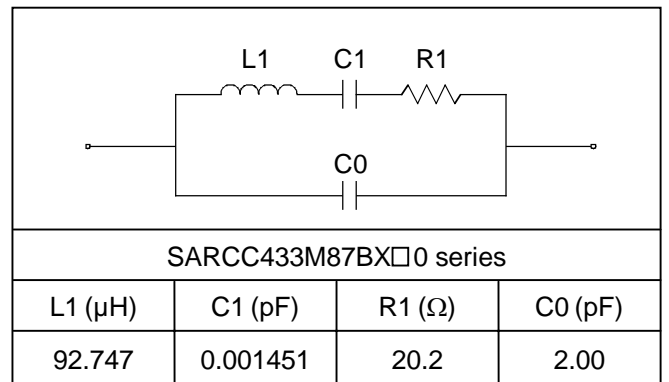

Recommended Land Pattern

