

# MS21047 Nutplate Series Specifications

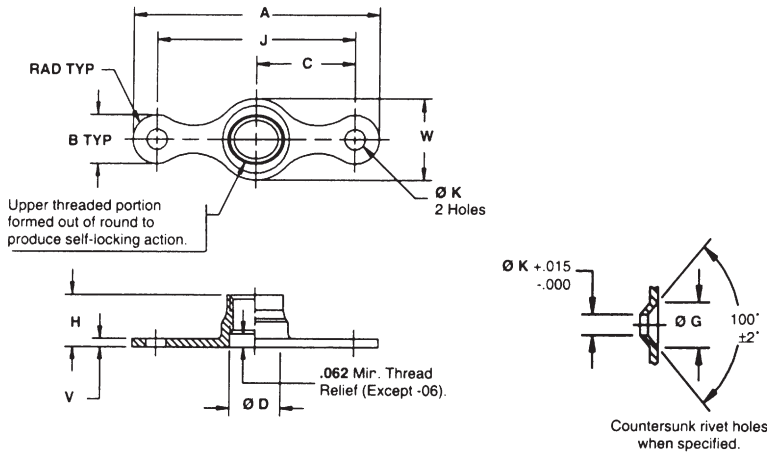

**MATERIAL:** C1050 carbon steel per AMS 5085 ( UNS G10500) or 8740 alloy steel per AMS 6322 (UNS G87400)

**FINISH:** Cadmium plate per QQ-P-416, Type II, Class 2 and Kaylube molybdenum disulfide dry film lubricant per MIL-L-46010

**PERFORMANCE:** MIL-N-25027

Part Number	Thread (MIL-S-8879)	A Max	B Ref	C ± .005	D Min	G ± .001	H Max	J ± .002	K + .005 - .000	V Max	W Max	Approx Weight Lbs/100
MS21047-06	.1380-32 UNJC-3B	.948	.215	.344	-	.200	.145	.688	.098	.032	.265	.14
MS21047-08	.1640-32 UNJC-3B	.948	.215	.344	.168	.200	.215	.688	.098	.032	.297	.19
MS21047-3	.1900-32 UNJF-3B	.948	.215	.344	.194	.200	.220	.688	.098	.032	.328	.22
MS21047-4	.2500-28 UNJF-3B	1.260	.215	.500	.254	.200	.281	1.000	.098	.040	.414	.43
MS21047-5	.3125-24 UNJF-3B	1.292	.265	.500	.317	.230	.328	1.000	.130	.050	.505	.68
MS21047-6	.3750-24 UNJF-3B	1.292	.265	.500	.379	.230	.344	1.000	.130	.055	.614	.87
MS21047-7	.4375-20 UNJF-3B	1.477	.327	.562	.442	.230	.390	1.125	.161	.074	.719	1.65

# MS21055 Nutplate Series Specifications

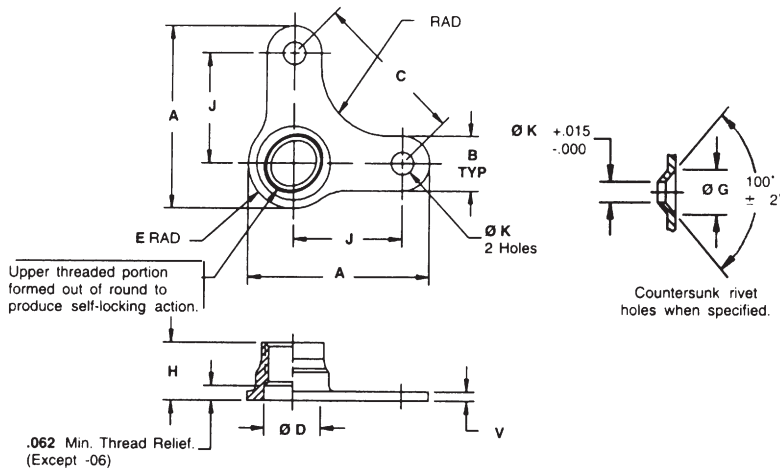

**MATERIAL:** Carbon steel per AMS 5085 ( UNS G10500) or alloy steel per AMS 6322 (UNS G8740)

**FINISH:** Cadmium plate per QQ-P-416, Type II, Class 2 and Kaylube molybdenum disulfide dry film lubricant per MIL-L-46010

**PERFORMANCE:** MIL-N-25027

Part Number	Thread (MIL-S-8879)	A Max	B Ref	C ± .002	D Min	E Ref	G ± .010	H Max	J ± .002	K + .005 - .000	V Ref	Approx Weight Lbs/100
MS21055-06	.1380-32 UNJC-3B	.637	.250	.486	-	.133	.200	.145	.344	.098	.032	.20
MS21055-08	.1640-32 UNJC-3B	.637	.250	.486	.168	.149	.200	.215	.344	.098	.032	.24
MS21055-3	.1900-32 UNJF-3B	.653	.250	.486	.194	.164	.200	.220	.344	.098	.032	.25
MS21055-4	.2500-28 UNJF-3B	.852	.250	.707	.254	.207	.200	.281	.500	.098	.040	.50
MS21055-5	.3125-24 UNJF-3B	.914	.322	.707	.317	.253	.230	.328	.500	.130	.050	.77
MS21055-6	.3750-24 UNJF-3B	.968	.322	.707	.379	.307	.230	.344	.500	.130	.055	.95
MS21055-7	.4375-20 UNJF-3B	1.101	.342	.795	.442	.363	-	.390	.562	.161	.074	1.68