

Dual 1-of-4 Decoder/ Demultiplexer

This device is a high speed, dual 1-of-4 decoder/multiplexer. The device has two independent decoders, each accepting two inputs and providing four mutually-exclusive active-LOW outputs. Each decoder has an active-LOW Enable input which can be used as a data input for a 4-output demultiplexer. Each half of this device can be used as a function generator providing four minterms of two variables.

- Advanced very high speed CMOS
- Outputs source/sink 24 mA
- Transmission line driving 50 ohms
- ACT has TTL compatible inputs
- AC Device Operation from 2 to 6 volts guaranteed
- DC & AC Parameters guaranteed over -40 to $+85^{\circ}\text{C}$

DV74AC139 DV74ACT139

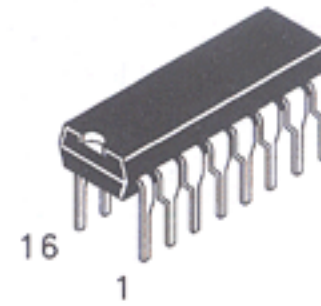

N Suffix
Plastic DIP
AVG-003 Case

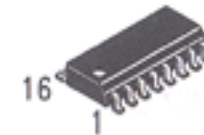

D Suffix
Plastic SOP
AVG-004 Case

LOGIC DIAGRAM

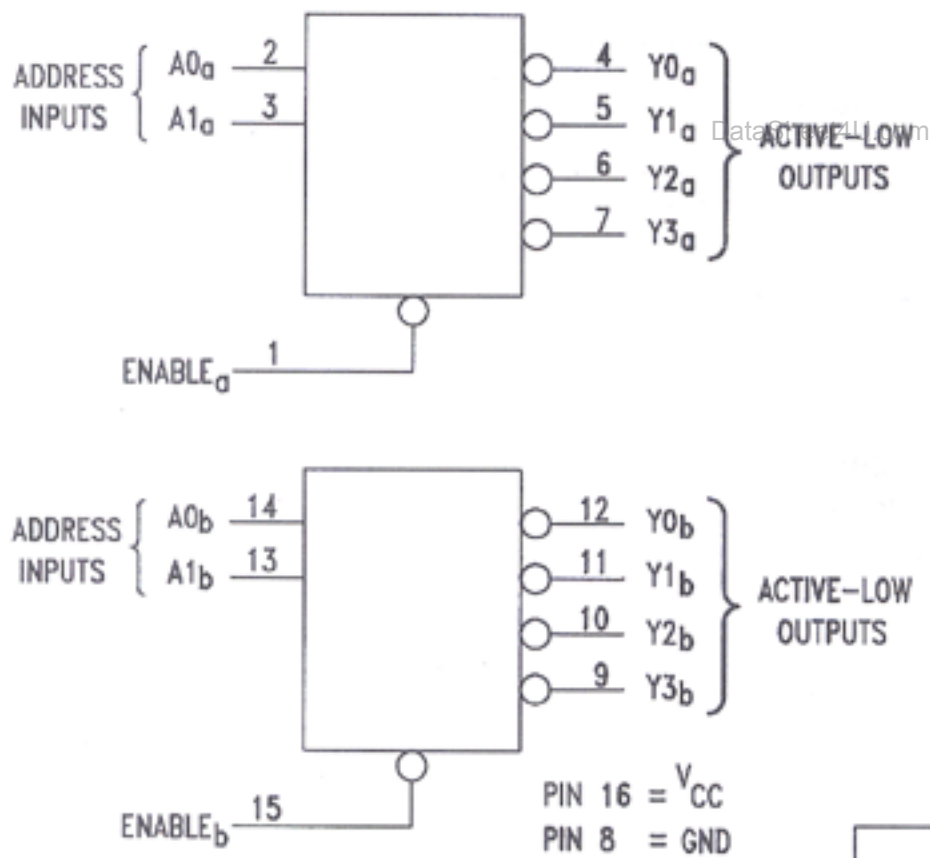

PIN ASSIGNMENT

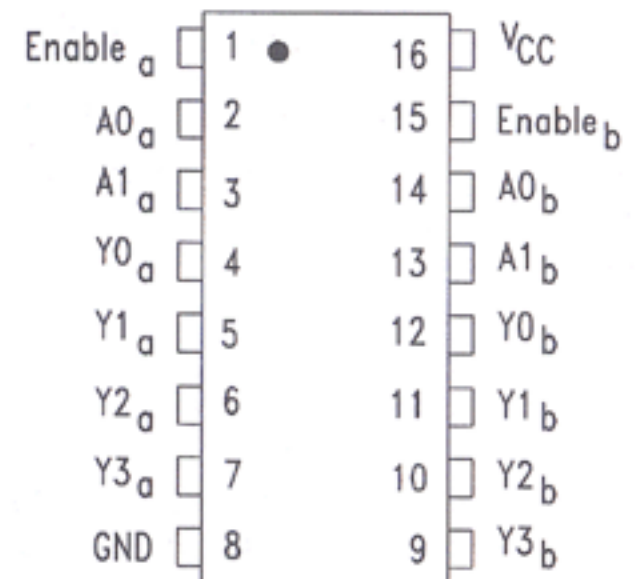

TRUTH TABLE

Inputs			Outputs			
Enable	A ₀	A ₁	Y ₀	Y ₁	Y ₂	Y ₃
H	X	X	H	H	H	H
L	L	L	L	H	H	H
L	H	L	H	L	H	H
L	L	H	H	H	L	H
L	H	H	H	H	H	L

H=HIGH Voltage Level

L=LOW Voltage Level

X=Either Low or High Logic Level

139

ABSOLUTE MAXIMUM RATINGS

Maximum ratings are those values beyond which damage to the device may occur.

Symbol	Parameter	AC139, ACT139	Unit
V _{CC}	DC Supply Voltage (Referenced to GND)	- 0.5 to +7.0	V
V _{IN}	DC Input Voltage (Referenced to GND)	- 0.5 to V _{CC} +0.5	V
V _{OUT}	DC Output Voltage (Referenced to GND)	- 0.5 to V _{CC} +0.5	V
I _{IN}	DC Input Current, per Pin	± 20	mA
I _{OUT}	DC Output Sink/Source Current, per Pin	± 50	mA
I _{CC}	DC V _{CC} or GND Current per Output Pin	± 50	mA
T _{stg}	Storage Temperature	- 65 to +150	°C

GUARANTEED OPERATING CONDITIONS

Symbol	Parameter	Min	Typ	Max	Unit	
V _{CC}	Supply Voltage	'AC	2.0	5.0	6.0	V
		'ACT	4.5	5.0	5.5	
V _{IN} , V _{OUT}	DC Input Voltage, Output Voltage, (Ref. to GND)	0		V _{CC}	V	
t _r , t _f	Input Rise and Fall Time (Note 1) AC Devices	V _{CC} @ 3.0 V			150	ns/V
		V _{CC} @ 4.5 V			40	ns/V
		V _{CC} @ 5.5 V			25	ns/V
t _r , t _f	Input Rise and Fall Time (Note 2) ACT Devices	V _{CC} @ 4.5 V			10	ns/V
		V _{CC} @ 5.5 V			8.0	ns/V
T _A	Operating Ambient Temperature Range	-40	25	85	°C	
C _{IN}	Input Capacitance V _{CC} = 5.0 V	V _{CC} = 5.0 V		4.5	pF	
C _{PD}	Power Dissipation Capacitance	V _{CC} = 5.0 V		40	pF	

1. V_{IN} from 30% to 70% V_{CC}2. V_{IN} from 0.8 to 2.0 V

DataSheet4U.com

AC — 139**DC ELECTRICAL CHARACTERISTICS**

Symbol	Parameter	Conditions	V _{CC} (V)	AC139			Unit
				TA = +25°C		TA = -40 to +85°C	
				Typ	Guaranteed Limits		
V _{IH}	Minimum High Level Input Voltage	V _{OUT} = 0.1V or V _{CC} - 0.1 V	3.0	1.5	2.1	2.1	V
			4.5	2.25	3.15	3.15	
			5.5	2.75	3.85	3.85	
V _{IL}	Maximum Low Level Input Voltage	V _{OUT} = 0.1V or V _{CC} - 0.1 V	3.0	1.5	0.9	0.9	V
			4.5	2.25	1.35	1.35	
			5.5	2.75	1.65	1.65	
V _{OH}	Minimum High Level Output Voltage	I _{OUT} = -50 μA	3.0	2.99	2.9	2.9	V
			4.5	4.49	4.4	4.4	
			5.5	5.49	5.4	5.4	
	I _{OH}	V _{IN} = V _{IL} or V _{IH} -12mA -24mA -24mA	3.0		2.56	2.46	V
			4.5		3.86	3.76	
			5.5		4.86	4.76	
V _{OL}	Maximum Low Level Output Voltage	I _{OUT} = 50 μA	3.0	0.002	0.1	0.1	V
			4.5	0.001	0.1	0.1	
			5.5	0.001	0.1	0.1	
	I _{OL}	V _{IN} = V _{IL} or V _{IH} 12mA 24mA 24mA	3.0		0.36	0.44	V
			4.5		0.36	0.44	
			5.5		0.36	0.44	

139

DC ELECTRICAL CHARACTERISTICS (continued)

Symbol	Parameter	Conditions	V _{CC} (V)	AC139			Unit
				TA = +25°C		TA = -40 to +85°C	
				Typ	Guaranteed Limits		
I _{IN}	Maximum Input Leakage Current	V _{IN} = V _{CC} or GND	5.5		±0.1	±1.0	μA

AC CHARACTERISTICS over full operating conditions

Symbol	Parameter (C _L = 50 pF)	V _{CC} ±10% (V)	AC139					Unit
			TA = +25°C			TA = -40°C to +85°C		
			Min	Typ	Max	Min	Max	
t _{PLH}	Propagation Delay A _n to Y _n	3.3	4.0	8.0	11.5	3.5	13	ns
t _{PHL}		5.0	3.0	6.5	8.5	2.5	9.5	
t _{PLH}	Propagation Delay E _n to Y _n	3.3	4.5	9.5	12	3.5	13	ns
t _{PHL}		5.0	3.5	7.0	8.5	3.0	10	
		3.3	4.0	8.0	10	3.0	11	ns
		5.0	2.5	6.0	7.5	2.5	8.5	ns

ACT — 139

DC ELECTRICAL CHARACTERISTICS

Symbol	Parameter	Conditions	V _{CC} * (V)	ACT139			Unit
				TA = +25°C		TA = -40 to +85°C	
				Typ	Guaranteed Limits		
V _{IH}	Minimum High Level Input Voltage	V _{OUT} = 0.1V or V _{CC} - 0.1 V	4.5	1.5	2.0	2.0	V
			5.5	1.5	2.0	2.0	
V _{IL}	Maximum Low Level Input Voltage	V _{OUT} = 0.1V or V _{CC} - 0.1 V	4.5	1.5	0.8	0.8	V
			5.5	1.5	0.8	0.8	
V _{OH}	Minimum High Level Output Voltage	I _{OUT} = -50 μA	4.5	4.49	4.4	4.4	V
			5.5	5.49	5.4	5.4	
		V _{IN} = V _{IL} or V _{IH} I _{OH} = -24mA -24 mA	4.5		3.86	3.76	V
			5.5		4.86	4.76	
V _{OL}	Maximum Low Level Output Voltage	I _{OUT} = 50 μA	4.5	0.001	0.1	0.1	V
			5.5	0.001	0.1	0.1	
		V _{IN} = V _{IL} or V _{IH} I _{OL} = 24mA 24 mA	4.5		0.36	0.44	V
			5.5		0.36	0.44	
I _{IN}	Maximum Input Leakage Current	V _{IN} = V _{CC} or GND	5.5		±0.1	±1.0	μA
ΔI _{CCT}	Additional Max I _{CC} /Input	V _{IN} = V _{CC} - 2.1 V	5.5	0.6		1.5	mA
I _{CC}	Maximum Quiescent Supply Current	V _{IN} = V _{CC} or GND	5.5		8.0	80	μA

139

AC CHARACTERISTICS over full operating conditions

Symbol	Parameter ($C_L = 50 \text{ pF}$)	V_{CC} $\pm 10\%$ (V)	ACT139					Unit
			$T_A = +25^\circ\text{C}$			$T_A = -40^\circ\text{C to } +85^\circ\text{C}$		
			Min	Typ	Max	Min	Max	
t_{PLH}	Propagation Delay, A_n to \bar{Y}_n	5.0	1.5	6.0	8.5	1.5	9.5	ns
t_{PHL}	Propagation Delay, A_n to \bar{Y}_n	5.0	1.5	6.0	9.5	1.5	10.5	ns
t_{PLH}	Propagation Delay, \bar{E}_n to \bar{Y}_n	5.0	2.5	7.0	10.0	2.0	11.0	ns
t_{PHL}	Propagation Delay, \bar{E}_n to \bar{Y}_n	5.0	2.0	7.0	9.5	1.5	10.5	ns

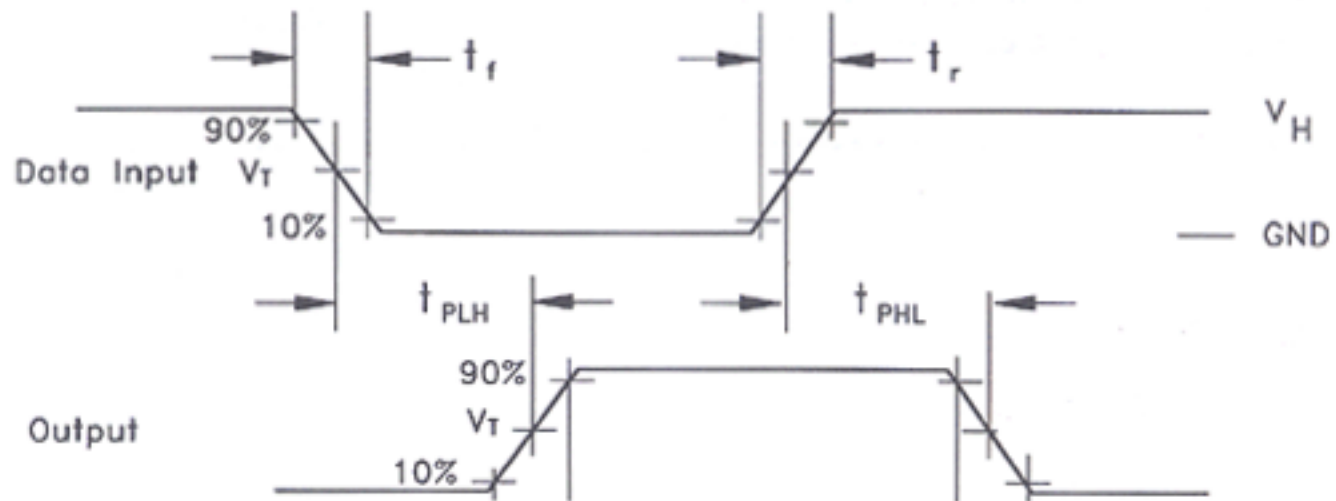
SWITCHING WAVEFORMS

Input and output threshold voltage:
 $V_T = 50\% V_{CC}$ for AC; 1.5V for ACT
 $V_H = V_{CC}$ for AC, 3V for ACT