

Fast thyristors

Type	V_{DRM} V_{RRM} V	I_{TRMS} A	I_{TSM} 25°C, 10 ms A	$\int i^2 dt$ 25°C, 10 ms A ² s	$(dv/dt)_{cr}$ V/ μ s	$(di/dt)_{cr}$ A/ μ s	$t_{q\ max}$ μ s	$T_{j\ max}$ °C	$R_{th\ JC}$ K/W	Fig.
BSt P61 13	200	1730	16000	1 300 000	200 S9: 500	200	f: 15 g: 18	140	0,03	1
BSt P61 20	300									
BSt P61 26	400									
BSt P61 33	500									
BSt P64 60	900	1300	10750	580 000	500	200	k: 25 l: 30	125	0,04	2
BSt P64 80	1200									
BSt P64 86	1300									
BSt Q 63120	1800	1300	9500	450 000	500 S10: 1000	200	n: 40 p: 50 q: 60	125	0,035	2
BSt Q 63133	2000									
BSt Q 64 80	1200	1500	11700	685000	500 S10: 1000	400	k: 25	125	0,040	
BSt Q 64 86	1300									
BSt Q 64 93	1400									
BSt R 63120	1800	1700	20500	2 100 000	500 S10: 1000	200	n: 40 p: 50 q: 60	120	0,020	3
BSt R 63133	2000									
BSt R 63 H 186	2800	1700	15900	1 260 000	1000	150	t: 120 u: 140	120	0,022	3
BSt R 63 H 200	3000									

Asymmetric thyristors

BSt R 60110	1600/20	2000	20000	2 000 000	1000	800	k: 25 l: 30	125	0,02	3
BSt R 60120	1800/20									
BSt R 60133	2000/20									
BSt R 62166	2500/20	2200	20000	2 000 000	1000	700	q: 55	125	0,02	3
BSt R 62186	2800/20									

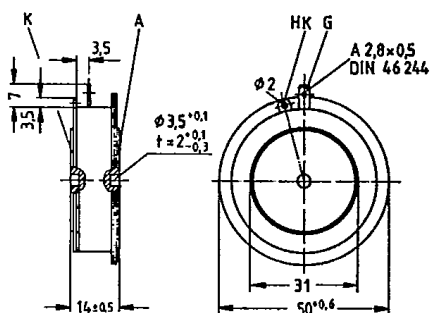

Fig. 1

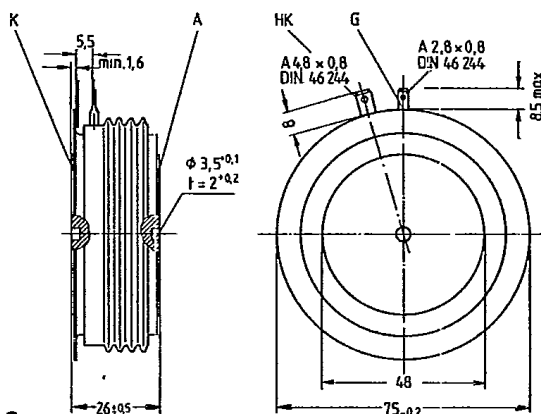

Fig. 3

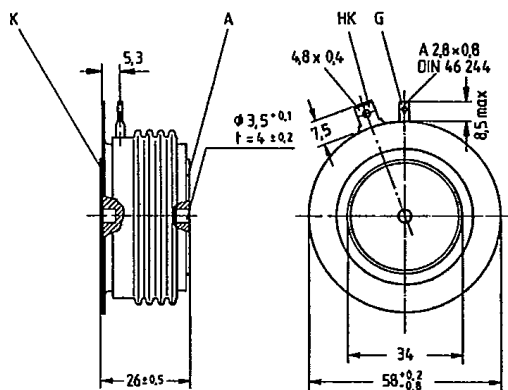

Fig. 2

Dimensions in mm