

High Voltage NPN Transistor

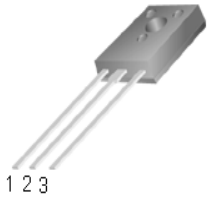

TO-126

Pin Definition

- 1. Emitter
- 2. Collector
- 3. Base

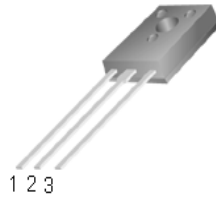

TO-126 R

Pin Definition

- 1. Base
- 2. Collector
- 3. Emitter

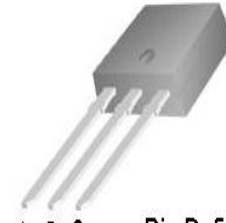

TO-251

Pin Definition

- 1. Base
- 2. Collector
- 3. Emitter

Features

- High Voltage
- Very High Switch Speed
- $BV_{CEO} : 400V$
- $BV_{CBO} : 800V$
- $I_C : 2.5A$
- $V_{CE(SAT)} : \max 1V @ I_C / I_B = 1A / 0.25A$
- Silicon Triple Diffused Type

INTERNAL SCHEMATIC DIAGRAM

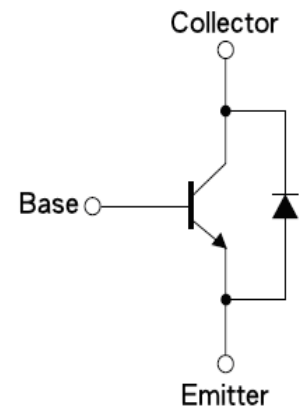

Application

- Electronic Ballasts
- Adapter
- Lighting

ABSOLUTE MAXIMUM RATINGS ($T_c = 25^\circ C$)

Parameter	Symbol	Max Rating	Unit
Collector-Base Voltage	VCBO	800	V
Collector-Emitter Voltage	VCEO	400	V
Emitter-Base Voltage	VEBO	9	V
Collector Current(DC)	IC	2.5	A
Collector Current(Pulse)	ICP	5	A
Total Power Dissipation(TO126)	PD	20	W
Total Power Dissipation(TO251)		30	
Junction Temperature	TJ	150	°C
Operating Junction and Storage Temperature Range	TSTG	-55 ~ +150	°C

ELECTRICAL CHARACTERISTICS (T_c = 25°C)

Parameter	Symbol	Test Condition	Min	Typ	Max	Unit
Collector-Base Voltage	BVCBO	IC = 1mA, IB=0	800	–	–	V
Collector-Emitter Breakdown Voltage	BVCEO	IC = 10mA, IE=0	400	–	–	V
Emitter- Base Breakdown Voltage	BVEBO	IE = 1mA, IC=0	9	–	–	V
Collector Cutoff Current	ICBO	VCB = 700V, IE=0	–	–	1	μA
Emitter Cutoff Current	IEBO	VEB = 9V, IC=0	–	–	1	μA
DC Current Gain	hFE1	VCE = 5V, IC=500mA	25	–	–	
	hFE2	VCE = 5V, IC=1A	15	–	30	
	hFE3	VCE = 5V, IC=2A	5	–	–	
Collector-Emitter Saturation Voltage	VCE(SAT1)	IC/IB = 0.5A / 0.1A	–	–	0.5	V
	VCE(SAT2)	IC/IB = 1A / 0.25A	–	–	1	
Base-Emitter Saturation Voltage	VBE(SAT1)	IC/IB = 0.5A / 0.1A	–	–	1.2	V
	VBE(SAT2)	IC/IB = 1A / 0.25A	–	–	1.4	

Resistive Load Switching Time (Ratings)

Rise Time	t _r	V _{CC} =250V, IC=1A,	–	–	0.8	μS
Storage Time	t _{STG}	IB1 = IB2 = 0.2A, tp = 25μS	–	3	6	μS
Fall Time	t _f	Duty Cycle ≤ 1%	–	0.2	0.7	μS

Electrical Characteristics Curve (Ta = 25°C, unless otherwise noted)

Figure 1. Static Characteristics

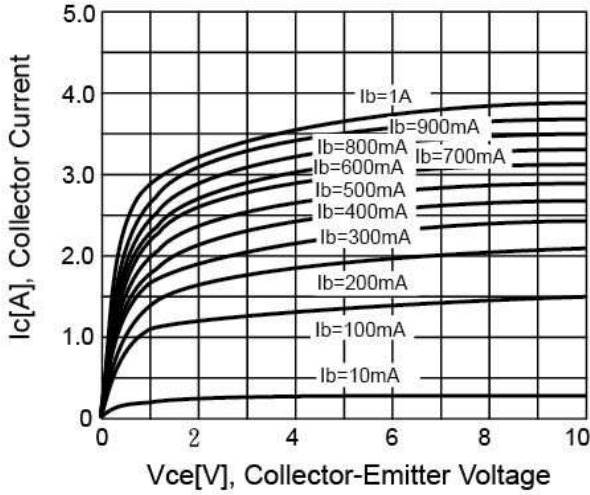

Figure 2. DC Current Gain

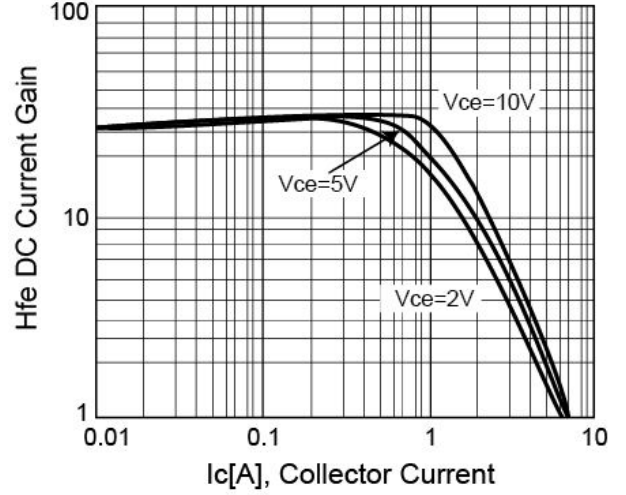

Figure 3. Vce(sat) v.s. Vbe(sat)

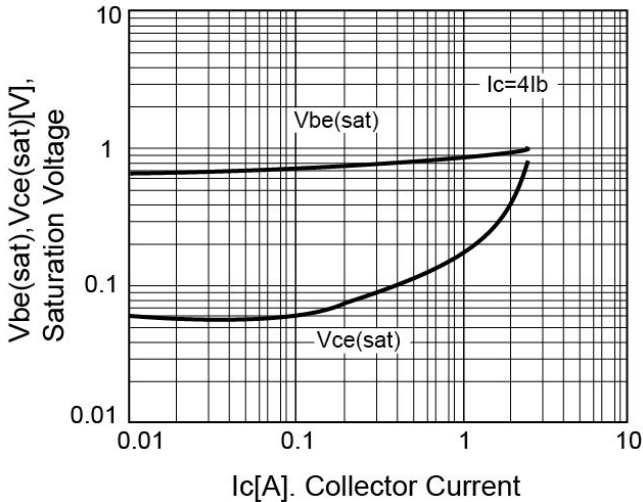

Figure 4. Power Derating

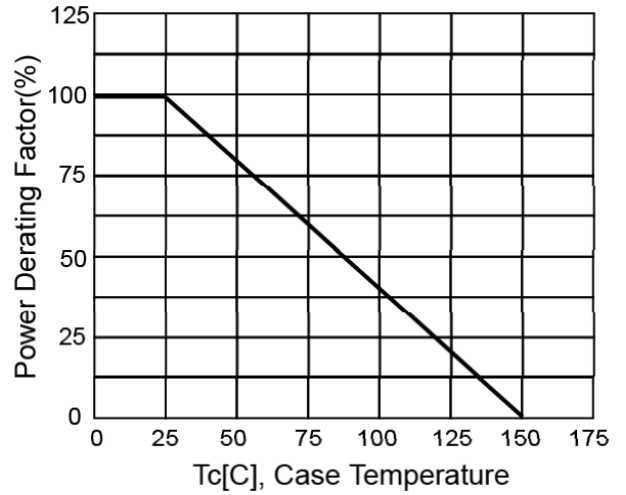

Figure 5. Reverse Bias SOA

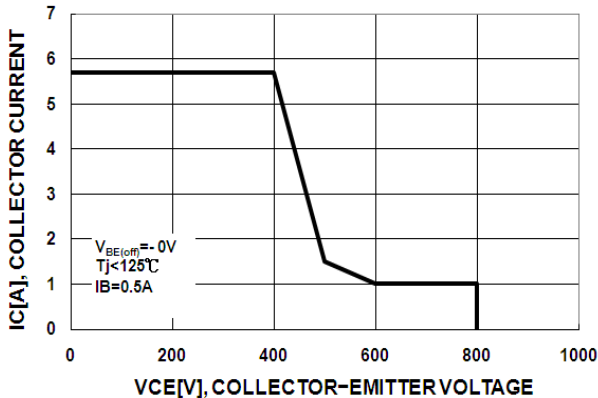
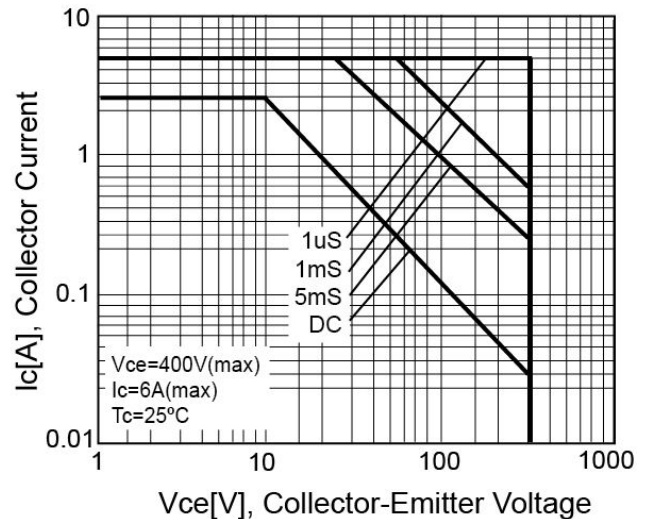

Figure 6. Safety Operating Area



Ordering Information

Type NO	Marking	Package Code
WTBV53DM	BV53DM	TO-126
WTBV53DMR	BV53DM	TO-126R

Marking and Pin Define

First Line	WTC	Company Name		
Second Line	BV53DM	Product Code		
Third Line	CC0TM	1st (Year Code)	A-2010 B-2011 C-2012 ...	
		2nd (Month Code)	A-Jan, B-Feb, C-Mar, D-Apr, E-May, F-Jun, G-Jul, H-Aug, I-Sep, J-Oct, K-Nov, L-Dec	
		3rd (Lot Code)	0~9 , A~Z	
		4th (Product Code)	M - MOS , T - Transistor, L - Linear	
		5th (Package Code)	I - TO251, D - TO252 , L - TO92, M - TO126, X - TO220, F - TO220F, Y - SOT89, S - SOP8	
		6th (Spec Code)	(Reserve)	

TO-126 Package Dimension

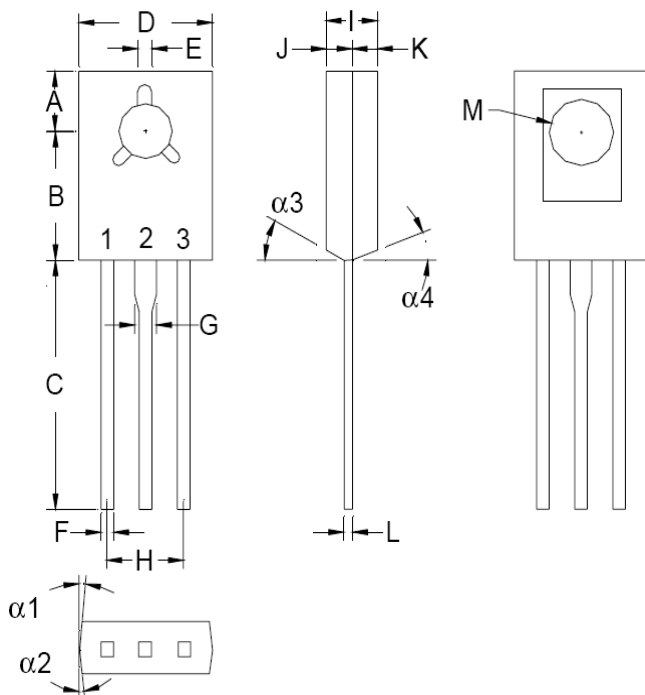

DIM	TO-126 DIMENSION			
	MILLIMETERS		INCHES	
	MIN	MAX	MIN	MAX
α1	—	3°	—	3°
α2	—	3°	—	3°
α3	—	3°	—	3°
α4	—	3°	—	3°
A	0.15	0.153	3.81	3.91
B	0.275	0.279	6.99	7.09
C	0.531	0.61	13.5	15.5
D	0.285	0.303	7.52	7.72
E	0.034	0.041	0.95	1.05
F	0.028	0.031	0.71	0.81
G	0.048	0.052	1.22	1.32
H	0.17	0.189	4.34	4.8
I	0.095	0.105	2.41	2.66
J	0.045	0.055	1.14	1.39
K	0.045	0.055	1.14	1.39
L	—	0.021	—	0.55
M	0.137	0.152	3.5	3.86

Ordering Information

Type NO	Marking	Package Code
WTI53D	53DI	TO-251

Marking and Pin Define

First Line	WTC	Company Name	
Second Line	53DI	Product Code	
Third Line	CC0TI	1st (Year Code)	A-2010 B-2011 C-2012 ...
		2nd (Month Code)	A-Jan, B-Feb, C-Mar, D-Apr, E-May, F-Jun, G-Jul, H-Aug, I-Sep, J-Oct, K-Nov, L-Dec
		3rd (Lot Code)	0~9 , A~Z
		4th (Product Code)	M - MOS , T - Transistor, L - Linear
		5th (Package Code)	I - TO251, D - TO252 , L - TO92, M - TO126, X - TO220, F - TO220F, Y - SOT89, S - SOP8
		6th (Spec Code)	(Reserve)

TO-251 Package Dimension

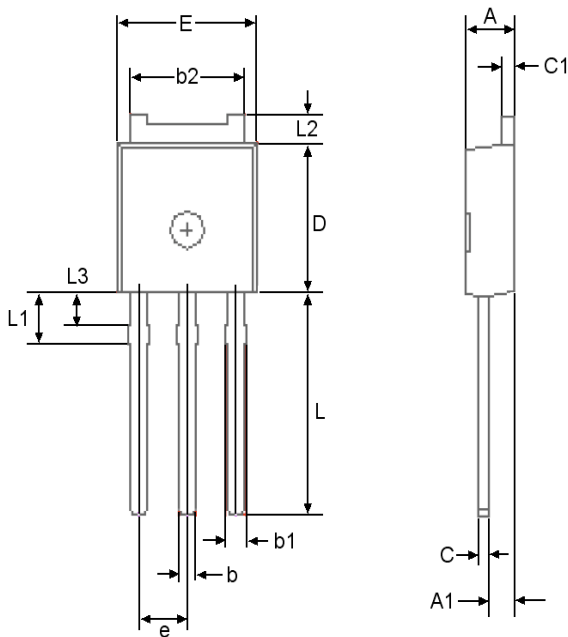

DIM	TO-251 DIMENSION			
	MILLIMETERS		INCHES	
	MIN	MAX	MIN	MAX
A	2.19	2.38	0.086	0.094
A1	0.89	1.14	0.035	0.045
b	0.64	0.89	0.025	0.035
b1	0.76	1.14	0.030	0.045
b2	5.21	5.46	0.205	0.215
C	0.46	0.58	0.018	0.023
C1	0.46	0.58	0.018	0.023
D	5.97	6.10	0.235	0.240
E	6.35	6.73	0.250	0.265
e	2.28 BSC.		0.90 BSC.	
L	8.89	9.65	0.350	0.380
L1	1.91	2.28	0.075	0.090
L2	0.89	1.27	0.035	0.050
L3	1.15	1.52	0.045	0.060