

NLSX5002

2-Bit 100 Mb/s Configurable Dual-Supply Level Translator

The NLSX5002 is a 2-bit configurable dual-supply autosensing bidirectional level translator that does not require a direction control pin. The I/O V_{CC} - and I/O V_L -ports are designed to track two different power supply rails, V_{CC} and V_L respectively. Both the V_{CC} and the V_L supply rails are configurable from 0.9 V to 4.5 V. This allows a logic signal on the V_L side to be translated to either a higher or a lower logic signal voltage on the V_{CC} side, and vice-versa.

The NLSX5002 offers the feature that the values of the V_{CC} and V_L supplies are independent. Design flexibility is maximized because V_L can be set to a value either greater than or less than the V_{CC} supply. In contrast, the majority of competitive auto sense translators have a restriction that the value of the V_L supply must be equal to less than ($V_{CC} - 0.4$) V.

The NLSX5002 has high output current capability, which allows the translator to drive high capacitive loads such as most high frequency EMI filters. Another feature of the NLSX5002 is that each I/O_ V_{Ln} and I/O_ V_{CCn} channel can function as either an input or an output.

An Output Enable (EN) input is available to reduce the power consumption. The EN pin can be used to disable both I/O ports by putting them in 3-state which significantly reduces the supply current from both V_{CC} and V_L . The EN signal is referenced to the V_L supply.

Features

- Wide V_{CC} , V_L Operating Range: 0.9 V to 4.5 V
- V_L and V_{CC} are independent
 - V_L may be greater than, equal to, or less than V_{CC}
- High-Speed with 140 Mb/s Guaranteed Data Rate for V_{CC} , $V_L > 1.8$ V
- Low Bit-to-Bit Skew
- Overvoltage Tolerant Enable and I/O Pins
- Non-Preferential Power-Up Sequencing
- Power-Off Protection
- Small Packaging: UQFN8, 1.4 mm x 1.2 mm, 0.4 mm Pitch
- These Devices are Pb-Free and are RoHS Compliant

Typical Applications

- Mobile Phones, PDAs, Other Portable Devices

Important Information

- ESD Protection for All Pins:
 - ♦ HBM (Human Body Model) > 8000 V
 - ♦ MM (Machine Model) > 400 V



ON Semiconductor®

<http://onsemi.com>

MARKING DIAGRAM



UQFN8
MU SUFFIX
CASE 523AS



A = Specific Device Code
M = Date Code

ORDERING INFORMATION

Device	Package	Shipping†
NLSX5002BMUTCG	UQFN8 (Pb-Free)	3000/Tape & Reel

†For information on tape and reel specifications, including part orientation and tape sizes, please refer to our Tape and Reel Packaging Specification Brochure, BRD8011/D.

NLSX5002

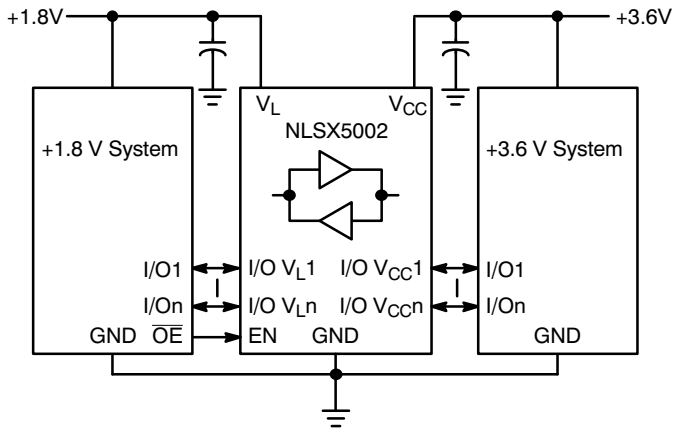

Figure 1. Typical Application Circuit

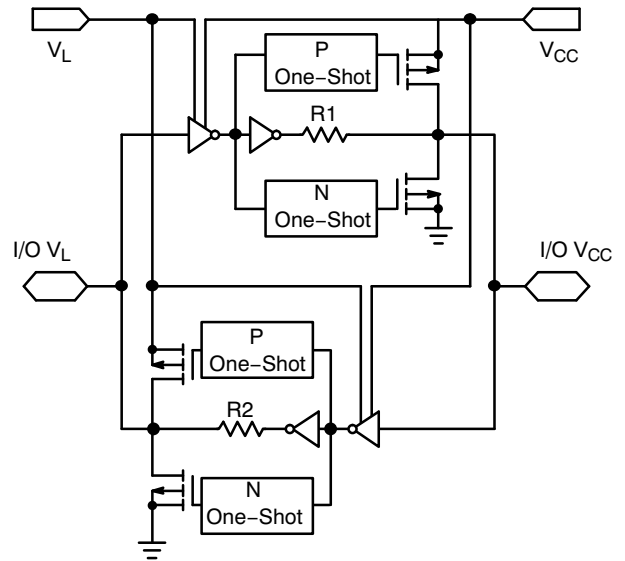

Figure 2. Simplified Functional Diagram (1 I/O Line)

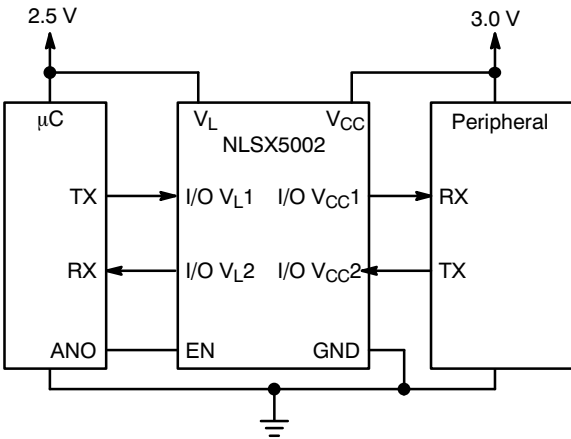

Figure 3. Application Example for $V_L < V_{CC}$

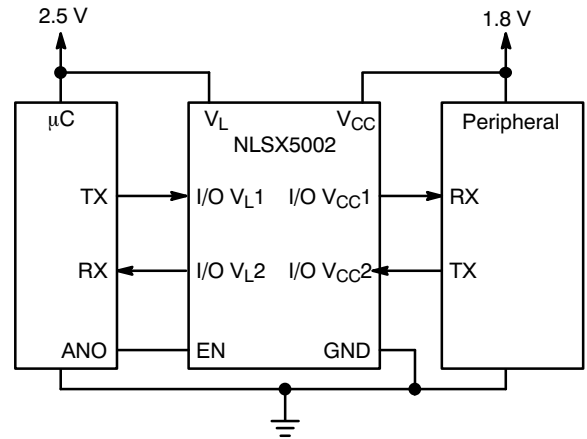

Figure 4. Application Example for $V_L > V_{CC}$

NLSX5002

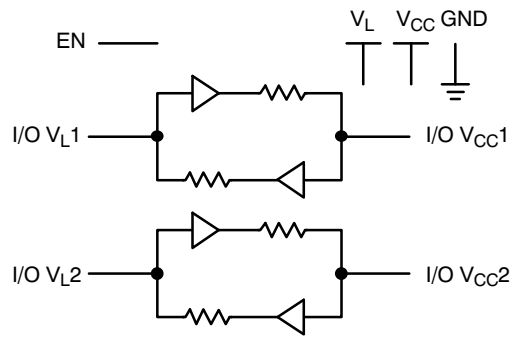

Figure 5. Logic Diagram

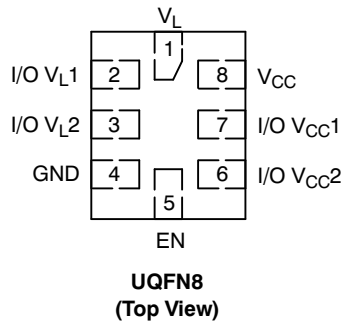

Figure 6. Pin Assignments

PIN ASSIGNMENT

Pins	Description
V _{CC}	V _{CC} Input Voltage
V _L	V _L Input Voltage
GND	Ground
EN	Output Enable
I/O V _{CCn}	I/O Port, Referenced to V _{CC}
I/O V _{Ln}	I/O Port, Referenced to V _L

FUNCTION TABLE

EN	Operating Mode
L	Hi-Z
H	I/O Buses Connected

NLSX5002

MAXIMUM RATINGS

Symbol	Parameter	Value	Condition	Unit
V _{CC}	I/O V _{CC} -side DC Supply Voltage	-0.5 to +5.5		V
V _L	I/O V _L -side DC Supply Voltage	-0.5 to +5.5		V
I/O V _{CC}	V _{CC} -Referenced DC Input/Output Voltage	-0.5 to +5.5		V
I/O V _L	V _L -Referenced DC Input/Output Voltage	-0.5 to +5.5		V
V _I	Enable Control Pin DC Input Voltage	-0.5 to +5.5		V
I _{IK}	DC Input Diode Current	-50	V _I < GND	mA
I _{OK}	DC Output Diode Current	-50	V _O < GND	mA
I _{CC}	DC Supply Current Through V _{CC}	± 100		mA
I _L	DC Supply Current Through V _L	± 100		mA
I _{GND}	DC Ground Current Through Ground Pin	± 100		mA
T _{STG}	Storage Temperature	-65 to +150		°C

Stresses exceeding Maximum Ratings may damage the device. Maximum Ratings are stress ratings only. Functional operation above the Recommended Operating Conditions is not implied. Extended exposure to stresses above the Recommended Operating Conditions may affect device reliability.

RECOMMENDED OPERATING CONDITIONS

Symbol	Parameter	Min	Max	Unit
V _{CC}	I/O V _{CC} -side Positive DC Supply Voltage	0.9	4.5	V
V _L	I/O V _L -side Positive DC Supply Voltage	0.9	4.5	V
V _I	Enable Control Pin Voltage (Referenced to V _L)	GND	4.5	V
V _{IO}	Bus Input/Output Voltage	I/O V _{CC} I/O V _L	4.5 4.5	V
T _A	Operating Temperature Range	-55	+125	°C
Δt/ΔV	Input Transition Rise or Rate V _I , V _{IO} from 30% to 70% of V _{CC} ; V _{CC} = 3.3 V ± 0.3 V	0	10	ns

NLSX5002

DC ELECTRICAL CHARACTERISTICS

Symbol	Parameter	Test Conditions (Note 1)	V _{CC} (V) (Note 2)	V _L (V) (Note 3)	-40°C to +85°C			-55°C to +125°C		Unit
					Min	Typ (Note 4)	Max	Min	Max	
V _{IHC}	I/O V _{CC} Input HIGH Voltage		0.9 – 4.5	0.9 – 4.5	2/3 * V _{CC}	–	–	2/3 * V _{CC}	–	V
V _{ILC}	I/O V _{CC} Input LOW Voltage		0.9 – 4.5	0.9 – 4.5	–	–	1/3 * V _{CC}	–	1/3 * V _{CC}	V
V _{IHL}	I/O V _L Input HIGH Voltage		0.9 – 4.5	0.9 – 4.5	2/3 * V _L	–	–	2/3 * V _L	–	V
V _{ILL}	I/O V _L Input LOW Voltage		0.9 – 4.5	0.9 – 4.5	–	–	1/3 * V _L	–	1/3 * V _L	V
V _{IH}	Control Pin Input HIGH Voltage	T _A = +25°C	0.9 – 4.5	0.9 – 4.5	2/3 * V _L	–	–	2/3 * V _L	–	V
V _{IL}	Control Pin Input LOW Voltage	T _A = +25°C	0.9 – 4.5	0.9 – 4.5	–	–	1/3 * V _L	–	1/3 * V _L	V
V _{OHC}	I/O V _{CC} Output HIGH Voltage	I/O V _{CC} source current = 20 μA	0.9 – 4.5	0.9 – 4.5	0.9 * V _{CC}	–	–	0.9 * V _{CC}	–	V
V _{OLC}	I/O V _{CC} Output LOW Voltage	I/O V _{CC} sink current = 20 μA	0.9 – 4.5	0.9 – 4.5	–	–	0.2	–	0.2	V
V _{OHL}	I/O V _L Output HIGH Voltage	I/O V _L source current = 20 μA	0.9 – 4.5	0.9 – 4.5	0.9 * V _L	–	–	0.9 * V _L	–	V
V _{OLL}	I/O V _L Output LOW Voltage	I/O V _L sink current = 20 μA	0.9 – 4.5	0.9 – 4.5	–	–	0.2	–	0.2	V
I _{QVCC}	V _{CC} Supply Current	EN = V _L , I _O = 0 A, (I/O V _{CC} = 0 V, I/O V _L = 0 V) or (I/O V _{CC} = V _{CC} , I/O V _L = V _L)	0.9 – 4.5	0.9 – 4.5	–	–	1	–	2.5	μA
I _{QVL}	V _L Supply Current		0.9 – 4.5	0.9 – 4.5	–	–	1	–	2.5	μA
I _{TS-VCC}	V _{CC} Tristate Output Mode Supply Current	T _A = +25°C, EN = 0 V	0.9 – 4.5	0.9 – 4.5	–	–	1	–	2.1	μA
I _{TS-VL}	V _L Tristate Output Mode Supply Current	T _A = +25°C, EN = 0 V	0.9 – 4.5	0.9 – 4.5	–	–	1	–	2.1	μA
I _{OZ}	I/O Tristate Output Mode Leakage Current	T _A = +25°C, EN = 0V	0.9 – 4.5	0.9 – 4.5	–	–	±1	–	±1.5	μA
I _I	Control Pin Input Current	T _A = +25°C	0.9 – 4.5	0.9 – 4.5	–	–	±1	–	±1	μA
I _{OFF}	Power Off Leakage Current	I/O V _{CC} = 0 to 4.5V, I/O V _L = 0 to 4.5 V	0	0	–	–	1	–	1.5	μA
			0.9 – 4.5	0	–	–	1	–	1.5	
			0	0.9 – 4.5	–	–	1	–	1.5	

1. Normal test conditions are V_I = 0 V, C_{IOVCC} ≤ 15 pF and C_{IOVL} ≤ 15 pF, unless otherwise specified.
2. V_{CC} is the supply voltage associated with the I/O V_{CC} port, and V_{CC} ranges from +0.9 V to 4.5 V under normal operating conditions.
3. V_L is the supply voltage associated with the I/O V_L port, and V_L ranges from +0.9 V to 4.5 V under normal operating conditions.
4. Typical values are for V_{CC} = +2.8 V, V_L = +1.8 V and T_A = +25°C. All units are production tested at T_A = +25°C. Limits over the operating temperature range are guaranteed by design.

NLSX5002

TIMING CHARACTERISTICS

Symbol	Parameter	Test Conditions (Note 5)	V _{CC} (V) (Note 6)	V _L (V) (Note 7)	-55°C to +125°C			Unit
					Min	Typ (Note 8)	Max	
t _{R-VCC}	I/O V _{CC} Rise Time	C _{I OVCC} = 15 pF	0.9 – 4.5	0.9 – 4.5	–	–	8.5	ns
			1.8 – 4.5	1.8 – 4.5	–	–	3.5	
t _{F-VCC}	I/O V _{CC} Fall Time	C _{I OVCC} = 15 pF	0.9 – 4.5	0.9 – 4.5	–	–	8.5	ns
			1.8 – 4.5	1.8 – 4.5	–	–	3.5	
t _{R-VL}	I/O V _L Rise Time	C _{I OVL} = 15 pF	0.9 – 4.5	0.9 – 4.5	–	–	8.5	ns
			1.8 – 4.5	1.8 – 4.5	–	–	3.5	
t _{F-VL}	I/O V _L Fall Time	C _{I OVL} = 15 pF	0.9 – 4.5	0.9 – 4.5	–	–	8.5	ns
			1.8 – 4.5	1.8 – 4.5	–	–	3.5	
Z _{OVCC}	I/O V _{CC} One-Shot Output Impedance		0.9	0.9 – 4.5	–	37	–	Ω
			1.8		–	20	–	
			4.5		–	6.0	–	
Z _{OVL}	I/O V _L One-Shot Output Impedance		0.9 – 4.5	0.9 1.8 4.5	–	37	–	Ω
					–	20	–	
					–	6.0	–	
t _{PD_VL-VCC}	Propagation Delay (Driving I/O V _{CC})	C _{I OVCC} = 25 pF	0.9 – 4.5	0.9 – 4.5	–	–	40	ns
			1.8 – 4.5	1.8 – 4.5	–	–	13	
t _{PD_VCC-VL}	Propagation Delay (Driving I/O V _L)	C _{I OVL} = 25 pF	0.9 – 4.5	0.9 – 4.5	–	–	40	ns
			1.8 – 4.5	1.8 – 4.5	–	–	13	
t _{SK}	Channel-to-Channel Skew	C _{I OVCC} = 15 pF, C _{I OVL} = 15 pF (Note 9)	0.9 – 4.5	0.9 – 4.5	–	–	0.15	ns
I _{IN_PEAK}	Input Driver Maximum Peak Current	EN = V _L ; I/O_V _{CC} = 1 MHz Square Wave, Amplitude = V _{CC} , or I/O_V _L = 1 MHz Square Wave, Amplitude = V _L	0.9 – 4.5	0.9 – 4.5	–	–	5.0	mA

5. Normal test conditions are V_I = 0 V, C_{I OVCC} ≤ 15 pF and C_{I OVL} ≤ 15 pF, unless otherwise specified.

6. V_{CC} is the supply voltage associated with the I/O V_{CC} port, and V_{CC} ranges from +0.9 V to 4.5 V under normal operating conditions.

7. V_L is the supply voltage associated with the I/O V_L port, and V_L ranges from +0.9 V to 4.5 V under normal operating conditions.

8. Typical values are for V_{CC} = +2.8 V, V_L = +1.8 V and T_A = +25°C. All units are production tested at T_A = +25°C. Limits over the operating temperature range are guaranteed by design.

9. Guaranteed by design.

NLSX5002

TIMING CHARACTERISTICS (continued)

Symbol	Parameter	Test Conditions (Note 10)	V _{CC} (V) (Note 11)	V _L (V) (Note 12)	-55°C to +125°C			Unit	
					Min	Typ (Note 13)	Max		
t _{EN-VCC}	I/O_V _{CC} Output Enable Time	t _{PZH}	C _{I_OV_{CC}} = 15 pF, I/O_V _L = V _L	0.9 – 4.5	0.9 – 4.5	–	–	160	ns
		t _{PZL}	C _{I_OV_{CC}} = 15 pF, I/O_V _L = 0 V	0.9 – 4.5	0.9 – 4.5	–	–	130	
t _{EN-VL}	I/O_V _L Output Enable Time	t _{PZH}	C _{I_OV_L} = 15 pF, I/O_V _{CC} = V _{CC}	0.9 – 4.5	0.9 – 4.5	–	–	160	ns
		t _{PZL}	C _{I_OV_L} = 15 pF, I/O_V _{CC} = 0 V	0.9 – 4.5	0.9 – 4.5	–	–	130	
t _{DIS-VCC}	I/O_V _{CC} Output Disable Time	t _{PHZ}	C _{I_OV_{CC}} = 15 pF, I/O_V _L = V _L	0.9 – 4.5	0.9 – 4.5	–	–	210	ns
		t _{PLZ}	C _{I_OV_{CC}} = 15 pF, I/O_V _L = 0 V	0.9 – 4.5	0.9 – 4.5	–	–	175	
t _{DIS-VL}	I/O_V _L Output Disable Time	t _{PHZ}	C _{I_OV_L} = 15 pF, I/O_V _{CC} = V _{CC}	0.9 – 4.5	0.9 – 4.5	–	–	210	ns
		t _{PLZ}	C _{I_OV_L} = 15 pF, I/O_V _{CC} = 0 V	0.9 – 4.5	0.9 – 4.5	–	–	175	
MDR	Maximum Data Rate		C _{I_O} = 15 pF	0.9 – 4.5	0.9 – 4.5	50	–	–	mbps
				1.8 – 4.5	1.8 – 4.5	140	–	–	

10. Normal test conditions are V_I = 0 V, C_{I_OV_{CC}} ≤ 15 pF and C_{I_OV_L} ≤ 15 pF, unless otherwise specified.

11. V_{CC} is the supply voltage associated with the I/O V_{CC} port, and V_{CC} ranges from +0.9 V to 4.5 V under normal operating conditions.

12. V_L is the supply voltage associated with the I/O V_L port, and V_L ranges from +0.9 V to 4.5 V under normal operating conditions.

13. Typical values are for V_{CC} = +3.3 V, V_L = +1.8 V and T_A = +25°C. All units are production tested at T_A = +25°C. Limits over the operating temperature range are guaranteed by design.

NLSX5002

DYNAMIC POWER CONSUMPTION ($T_A = +25^\circ\text{C}$)

Symbol	Parameter	Test Conditions	V _{CC} (V) (Note 14)	V _L (V) (Note 15)	Typ (Note 16)	Unit
C _{PD_VL}	Power Dissipation Capacitance (Referred to V _L)	V _L = Input port, V _{CC} = Output Port C _{Load} = 0, f = 1 MHz, EN = V _L (Output enabled)	0.9	4.5	13	pF
			1.5	1.8	7.0	
			1.8	1.5	6.0	
			1.8	1.8	6.0	
			1.8	2.8	7.0	
			2.5	2.5	6.0	
			2.8	1.8	6.0	
			4.5	0.9	10	
		V _{CC} = Input port, V _L = Output Port C _{Load} = 0, f = 1 MHz, EN = V _L (Output enabled)	0.9	4.5	19	pF
			1.5	1.8	16	
			1.8	1.5	16	
			1.8	1.8	16	
			1.8	2.8	16	
			2.5	2.5	16	
C _{PD_VCC}	Power Dissipation Capacitance (Referred to V _{CC})	V _L = Input port, V _{CC} = Output Port C _{Load} = 0, f = 1 MHz, EN = V _L (Output enabled)	0.9	4.5	16	pF
			1.5	1.8	17	
			1.8	1.5	17	
			1.8	1.8	17	
			1.8	2.8	17	
			2.5	2.5	18	
			2.8	1.8	18	
			4.5	0.9	21	
		V _{CC} = Input port, V _L = Output Port C _{Load} = 0, f = 1 MHz, EN = V _L (Output enabled)	0.9	4.5	13	pF
			1.5	1.8	6.0	
			1.8	1.5	7.0	
			1.8	1.8	7.0	
			1.8	2.8	6.0	
			2.5	2.5	7.0	
2.8	1.8	7.0				
4.5	0.9	15				

14. V_{CC} is the supply voltage associated with the I/O V_{CC} port, and V_{CC} ranges from +0.9 V to 4.5 V under normal operating conditions.

15. V_L is the supply voltage associated with the I/O V_L port, and V_L ranges from +0.9 V to 4.5 V under normal operating conditions.

16. Typical values are at T_A = +25°C.

17. C_{PD_VL} and C_{PD_VCC} are defined as the value of the IC's equivalent capacitance from which the operating current can be calculated for the V_L and V_{CC} power supplies, respectively. I_{CC} = I_{CC} (dynamic) + I_{CC} (static) ≈ I_{CC}(operating) ≈ C_{PD} × V_{CC} × f_{IN} × N_{SW} where I_{CC} = I_{CC_VCC} + I_{CC_VL} and N_{SW} = total number of outputs switching.

NLSX5002

STATIC POWER CONSUMPTION ($T_A = +25^\circ\text{C}$)

Symbol	Parameter	Test Conditions	V _{CC} (V) (Note 18)	V _L (V) (Note 19)	Typ (Note 20)	Unit
C _{PD_VL}	Power Dissipation Capacitance (Referred to V _L)	V _L = Input port, V _{CC} = Output Port C _{Load} = 0, f = 1 MHz, EN = GND (outputs disabled)	0.9	4.5	0.01	pF
			1.5	1.8	0.01	
			1.8	1.5	0.01	
			1.8	1.8	0.01	
			1.8	2.8	0.01	
			2.5	2.5	0.01	
			2.8	1.8	0.01	
			4.5	0.9	0.01	
		V _{CC} = Input port, V _L = Output Port C _{Load} = 0, f = 1 MHz, EN = GND (outputs disabled)	0.9	4.5	0.01	pF
			1.5	1.8	0.01	
			1.8	1.5	0.01	
			1.8	1.8	0.01	
			1.8	2.8	0.01	
			2.5	2.5	0.01	
2.8	1.8		0.01			
4.5	0.9		0.01			
C _{PD_VCC}	Power Dissipation Capacitance (Referred to V _{CC})	V _L = Input port, V _{CC} = Output Port C _{Load} = 0, f = 1 MHz, EN = GND (outputs disabled)	0.9	4.5	0.01	pF
			1.5	1.8	0.01	
			1.8	1.5	0.01	
			1.8	1.8	0.01	
			1.8	2.8	0.01	
			2.5	2.5	0.01	
			2.8	1.8	0.01	
			4.5	0.9	0.01	
		V _{CC} = Input port, V _L = Output Port C _{Load} = 0, f = 1 MHz, EN = GND (outputs disabled)	0.9	4.5	0.01	pF
			1.5	1.8	0.01	
			1.8	1.5	0.01	
			1.8	1.8	0.01	
			1.8	2.8	0.01	
			2.5	2.5	0.01	
2.8	1.8		0.01			
4.5	0.9		0.01			

18. V_{CC} is the supply voltage associated with the I/O V_{CC} port, and V_{CC} ranges from +0.9 V to 4.5 V under normal operating conditions.

19. V_L is the supply voltage associated with the I/O V_L port, and V_L ranges from +0.9 V to 4.5 V under normal operating conditions.

20. Typical values are at T_A = +25°C

NLSX5002

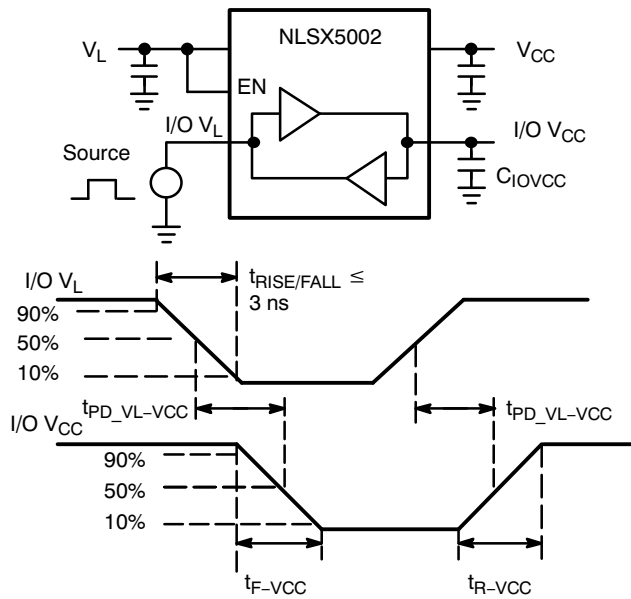

Figure 7. Driving I/O V_{CC} Test Circuit and Timing

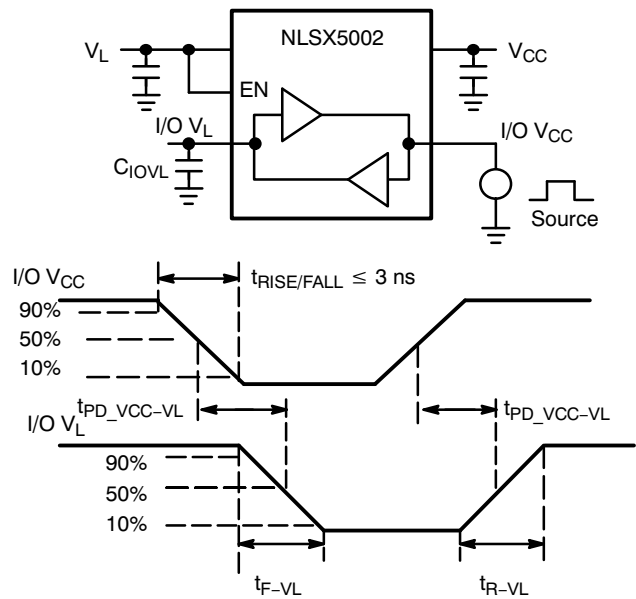
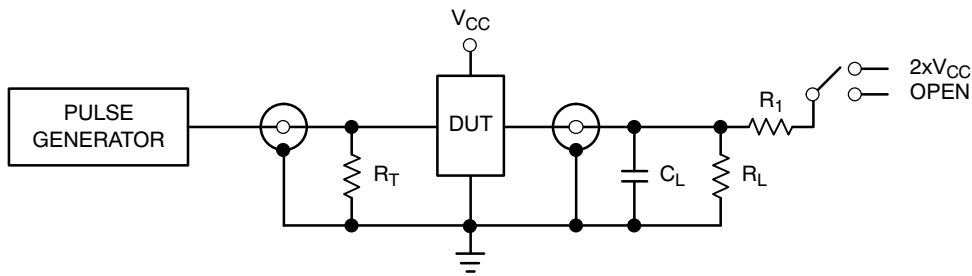

Figure 8. Driving I/O V_L Test Circuit and Timing



Test	Switch
t _{PZH} , t _{PHZ}	Open
t _{PZL} , t _{PLZ}	2 x V _{CC}

C_L = 15 pF or equivalent (Includes jig and probe capacitance)
 R_L = R₁ = 50 kΩ or equivalent
 R_T = Z_{OUT} of pulse generator (typically 50 Ω)

Figure 9. Test Circuit for Enable/Disable Time Measurement

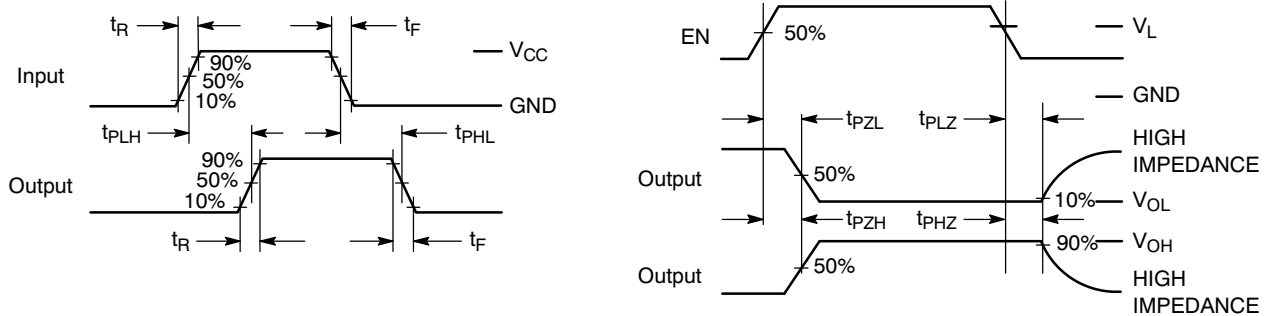

Figure 10. Timing Definitions for Propagation Delays and Enable/Disable Measurement

IMPORTANT APPLICATIONS INFORMATION

Level Translator Architecture

The NLSX5002 auto-sense translator provides bi-directional logic voltage level shifting to transfer data in multiple supply voltage systems. These level translators have two supply voltages, V_L and V_{CC} , which set the logic levels on the input and output sides of the translator. When used to transfer data from the I/O V_L to the I/O V_{CC} ports, input signals referenced to the V_L supply are translated to output signals with a logic level matched to V_{CC} . In a similar manner, the I/O V_{CC} to I/O V_L translation shifts input signals with a logic level compatible to V_{CC} to an output signal matched to V_L .

The NLSX5002 translator consists of bi-directional channels that independently determine the direction of the data flow without requiring a directional pin. One-shot circuits are used to detect the rising or falling input signals. In addition, the one-shots decrease the rise and fall times of the output signal for high-to-low and low-to-high transitions.

Input Driver Requirements

Auto-sense translators such as the NLSX5002 have a wide bandwidth, but a relatively small DC output current rating. The high bandwidth of the bi-directional I/O circuit is used to quickly transform from an input to an output driver and vice versa. The I/O ports have a modest DC current output specification so that the output driver can be over driven when data is sent in the opposite direction. For proper operation, the input driver to the auto-sense translator should be capable of driving 5 mA of peak output current. The bi-directional configuration of the translator results in both input stages being active for a very short time period. Although the peak current from the input signal circuit is relatively large, the average current is small and consistent with a standard CMOS input stage.

Enable Input (EN)

The NLSX5002 translator has an Enable pin (EN) that provides tri-state operation at the I/O pins. Driving the Enable pin to a low logic level minimizes the power consumption of the device and drives the I/O V_{CC} and I/O

V_L pins to a high impedance state. Normal translation operation occurs when the EN pin is equal to a logic high signal. The EN pin is referenced to the V_L supply and has Over-Voltage Tolerant (OVT) protection.

Uni-Directional versus Bi-Directional Translation

The NLSX5002 translator can function as a non-inverting uni-directional translator. One advantage of using the translator as a uni-directional device is that each I/O pin can be configured as either an input or output. The configurable input or output feature is especially useful in applications such as SPI that use multiple uni-directional I/O lines to send data to and from a device. The flexible I/O port of the auto sense translator simplifies the trace connections on the PCB.

Power Supply Guidelines

The values of the V_L and V_{CC} supplies can be set to anywhere between 0.9 and 4.5 V. Design flexibility is maximized because V_L may be either greater than or less than the V_{CC} supply. In contrast, the majority of the competitive auto sense translators has a restriction that the value of the V_L supply must be equal to less than $(V_{CC} - 0.4)$ V.

The sequencing of the power supplies will not damage the device during power-up operation. In addition, the I/O V_{CC} and I/O V_L pins are in the high impedance state if either supply voltage is equal to 0 V. For optimal performance, 0.01 to 0.1 μ F decoupling capacitors should be used on the V_L and V_{CC} power supply pins. Ceramic capacitors are a good design choice to filter and bypass any noise signals on the voltage lines to the ground plane of the PCB. The noise immunity will be maximized by placing the capacitors as close as possible to the supply and ground pins, along with minimizing the PCB connection traces.

The NLSX5002 translators have a power down feature that provides design flexibility. The output ports are disabled when either power supply is off (V_L or $V_{CC} = 0$ V). This feature causes all of the I/O pins to be in the power saving high impedance state.

NLSX5002

PACKAGE DIMENSIONS

UQFN8 1.4x1.2, 0.4P CASE 523AS ISSUE A

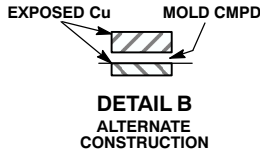
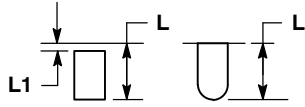
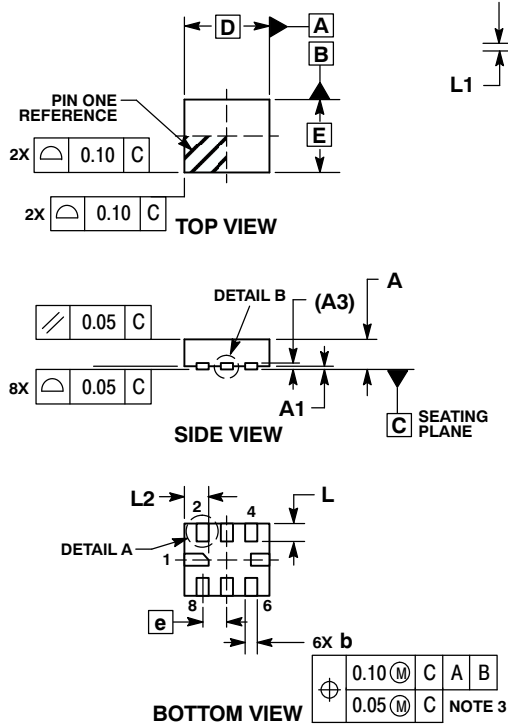

NOTES:

1. DIMENSIONING AND TOLERANCING PER ASME Y14.5M, 1994.
2. CONTROLLING DIMENSION: MILLIMETERS.
3. DIMENSION b APPLIES TO PLATED TERMINAL AND IS MEASURED BETWEEN 0.15 AND 0.25 mm FROM THE TERMINAL TIP.

MILLIMETERS		
DIM	MIN	MAX
A	0.45	0.55
A1	0.00	0.05
A3	0.13	REF
b	0.15	0.25
D	1.40	BSC
E	1.20	BSC
e	0.40	BSC
L	0.20	0.40
L1	---	0.15
L2	0.30	0.50

SOLDERING FOOTPRINT*

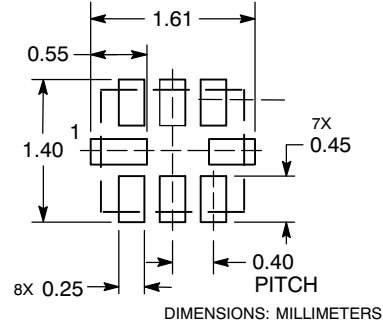

*For additional information on our Pb-Free strategy and soldering details, please download the ON Semiconductor Soldering and Mounting Techniques Reference Manual, SOLDERRM/D.

ON Semiconductor and are registered trademarks of Semiconductor Components Industries, LLC (SCILLC). SCILLC reserves the right to make changes without further notice to any products herein. SCILLC makes no warranty, representation or guarantee regarding the suitability of its products for any particular purpose, nor does SCILLC assume any liability arising out of the application or use of any product or circuit, and specifically disclaims any and all liability, including without limitation special, consequential or incidental damages. "Typical" parameters which may be provided in SCILLC data sheets and/or specifications can and do vary in different applications and actual performance may vary over time. All operating parameters, including "Typicals" must be validated for each customer application by customer's technical experts. SCILLC does not convey any license under its patent rights nor the rights of others. SCILLC products are not designed, intended, or authorized for use as components in systems intended for surgical implant into the body, or other applications intended to support or sustain life, or for any other application in which the failure of the SCILLC product could create a situation where personal injury or death may occur. Should Buyer purchase or use SCILLC products for any such unintended or unauthorized application, Buyer shall indemnify and hold SCILLC and its officers, employees, subsidiaries, affiliates, and distributors harmless against all claims, costs, damages, and expenses, and reasonable attorney fees arising out of, directly or indirectly, any claim of personal injury or death associated with such unintended or unauthorized use, even if such claim alleges that SCILLC was negligent regarding the design or manufacture of the part. SCILLC is an Equal Opportunity/Affirmative Action Employer. This literature is subject to all applicable copyright laws and is not for resale in any manner.

PUBLICATION ORDERING INFORMATION

LITERATURE FULFILLMENT:

Literature Distribution Center for ON Semiconductor
P.O. Box 5163, Denver, Colorado 80217 USA
Phone: 303-675-2175 or 800-344-3860 Toll Free USA/Canada
Fax: 303-675-2176 or 800-344-3867 Toll Free USA/Canada
Email: orderlit@onsemi.com

N. American Technical Support: 800-282-9855 Toll Free
USA/Canada
Europe, Middle East and Africa Technical Support:
Phone: 421 33 790 2910
Japan Customer Focus Center
Phone: 81-3-5817-1050

ON Semiconductor Website: www.onsemi.com

Order Literature: <http://www.onsemi.com/orderlit>

For additional information, please contact your local Sales Representative