

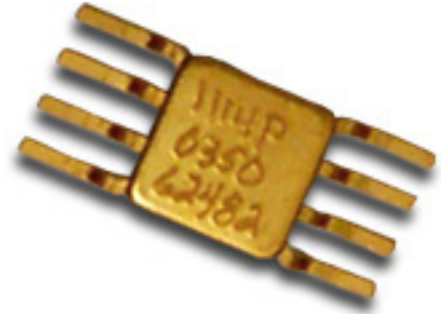

SURFACE MOUNT TUNNEL DETECTORS

Advanced Control Components offers a series of tunnel detectors built in surface mount modules. These modules include complete detector circuits with DC returns and RF bypass capacitors. Options include input pads or limiters to modify the operational range or offer input protection. The small size of surface mount packages allows for easier design and lower cost. They offer high reliability and are hermetically sealed, making them ideal for operation in harsh environments. Thermal stability is one of the prime advantages of tunnel diode detectors. Frequencies range from 10MHz to 4GHz. The output will not vary more than +/-0.15dB over the temperature range of -65°C to +100°C at these low frequencies. They have high sensitivity without any bias needed for operation. Standard output polarity is negative, but positive polarity output is an option.



Features:

- Thermal Stability
- Small Size
- No Bias Required
- Low Video Impedance

Applications:

- Transmitter Monitoring
- Missile Guidance Systems
- Input to Low-Noise Amplifiers
- Broadband Or Narrowband ECM Receivers
- Power and Signal Monitors
- Doppler Radar and Beacon Receivers
- Matched units available for Multi-channel Receivers, Amplitude Comparator Systems and Discriminators

Frequency Range (GHz)	Part (1) Number	Minimum (2)	Flatness vs Frequency (+/-dB)		Standard (4)	Standard Case Styles	Optional Case Styles
		Sensitivity K (mV/mW)	Typical (3) VSWR	Video Capacitance (pF)			
0.01 - 0.5	ACTM1114N	800	0.3	2.3:1	270	M47	M10
0.25 - 0.75	ACTM1133N	900	0.2	2.3:1	270	M47	M10
0.5 - 1	ACTM1146N	1000	0.2	2.3:1	270	M47	M10
0.5 - 2	ACTM1136N	1000	0.2	2.3:1	75	M47	M10
1 - 2	ACTM1137N	1000	0.2	2.3:1	75	M47	M10
0.1 - 4	ACTM1129N	900	0.4	2.3:1	270	M47	M10
2 - 4	ACTM1130N	900	0.3	2.3:1	12	M47	M10

NOTES:

- 1) Available in both negative and positive polarities, substitute "N" or "P" in part number.
- 2) Diode values can be changed to alter the level of sensitivity. As sensitivity is increased, VSWR will degrade. VSWR will improve as sensitivity is lowered. Flatness and TSS will also be influenced by these changes. If your applications require something special, please contact the factory.
- 3) VSWR measured at or below -20dBm input power level.
- 4) Video capacitance is used for RF bypass. This value can be changed if required for video response time or other considerations. Contact the factory if value other than those shown are needed.



ENVIRONMENTAL SPECIFICATIONS:

MIL-E-5400, MIL-STD-202, MIL-E-16400
 Operating Temp: -65°C to +100°C
 Storage Temp: -65°C to +100°C
 Humidity: MIL-STD-202F, M103, Cond B
 Shock: MIL-STD-202F, M213, Cond B
 Altitude: MIL-STD-202F, M105, Cond B
 Vibration : MIL-STD-202F, M204, Cond B
 Thermal Shock: MIL-STD-202F, M107, Cond A
 Temperature Cycle: MIL-STD-202F, M105C, Cond D
 Maximum Input Power: +14dBm
 (This allows for 3dB margin from possible burnout at +17dBm)

SCREENING :

Standard Screening:
 Internal Visual per MIL-STD-883, Method 2017
 Temperature Cycle: -65°C to +100°C, 10 cycles
Optional High-Rel Screening (Ref MIL-PRF-38534):
 Internal Visual per MIL-STD-883, Method 2017
 Stabilization Bake per MIL-STD-883, Method 1008
 Temperature Cycle per MIL-STD-883, Method 1010
 Constant Acceleration per MIL-STD-883, Method 2001
 Burn-in per MIL-STD-883, Method 1015
 Leak Test per MIL-STD-883, Method 1014
 External Visual per MIL-STD-883, Method 2009

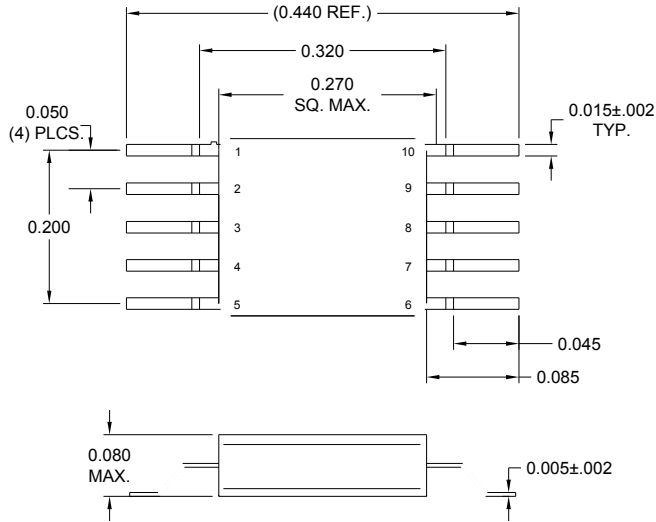

PIN	CONNECTION	PIN	CONNECTION
1	N/C	10	GND
2	INPUT	9	N/C
3	N/C	8	N/C
4	N/C	7	OUTPUT
5	GND	6	N/C

M10

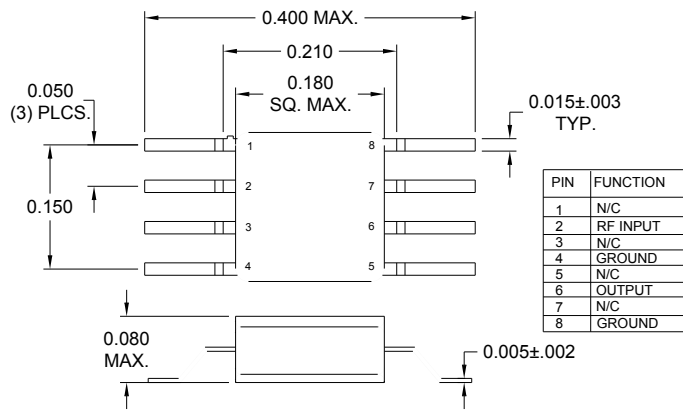

PIN	FUNCTION
1	N/C
2	RF INPUT
3	N/C
4	GROUND
5	N/C
6	OUTPUT
7	N/C
8	GROUND

M47

Part Number Ordering Information:

Example: ACTM1130NM4720
 ACTM1130 Surface Mount Tunnel Detector, 2 - 4GHz
 N: Negative output polarity
 M47: Package Type
 20: 20pF custom video capacitance (omit for standard value)