



UU6043B

Preliminary

LINEAR INTEGRATED CIRCUIT

FLASHER IC WITH 18mΩ SHUNT

DESCRIPTION

The UTC **UU6043B** is a microconductor integrated circuit designed for relay-controlled automotive flashers where a high level EMC is required.

Lamp outage is indicated by frequency doubling during hazard warning as well as direction mode.

FEATURES

- * Temperature and supply voltage compensated frequency
- * Warning indication of lamp failure by means of frequency doubling
- * Relay driver output with high current carrying capacity and low saturation output
- * Minimum lamp load for flasher operation: $\geq 1\text{ W}$
- * Very low susceptibility to EMI

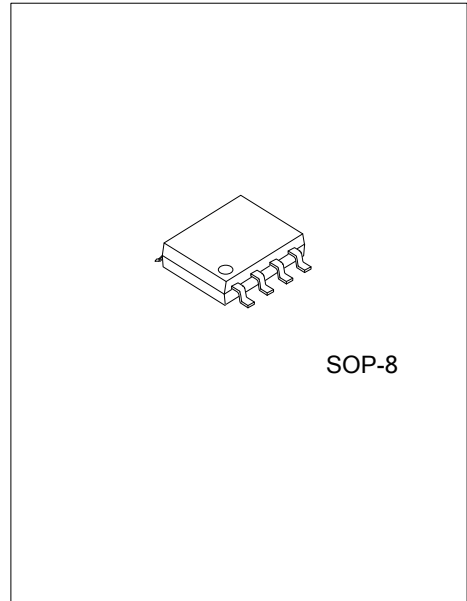

ORDERING INFORMATION

Ordering Number		Package	Packing
Lead Free	Halogen Free		
UU6043BL-S08-T	UU6043BG-S08-T	SOP-8	Tube
UU6043BL-S08-R	UU6043BG-S08-R	SOP-8	Tape Reel

UU6043BL-S08-T 	(1) Packing Type (2) Package Type (3) Lead Free	(1) T: Tube, R: Tape Reel (2) S08: SOP-8 (3) L: Lead Free, G: Halogen Free
--------------------	-------------------------------------------------------	----------------------------------------------------------------------------------

■ PIN CONFIGURATION

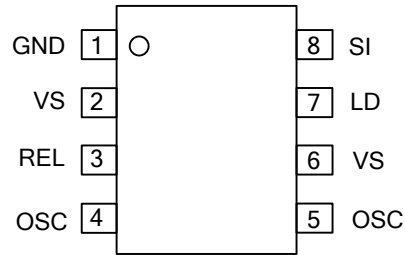

■ PIN DESCRIPTION

PIN NO.	PIN NAME	DESCRIPTION
1	GND	IC ground
2	VS	Supply voltage
3	REL	Relay driver
4	OSC	C ₁ Oscillator
5	OSC	R ₁ Oscillator
6	VS	Supply voltage, Sense
7	LD	Lamp outage detection
8	SI	Start input (49a)

■ BLOCK DIAGRAM

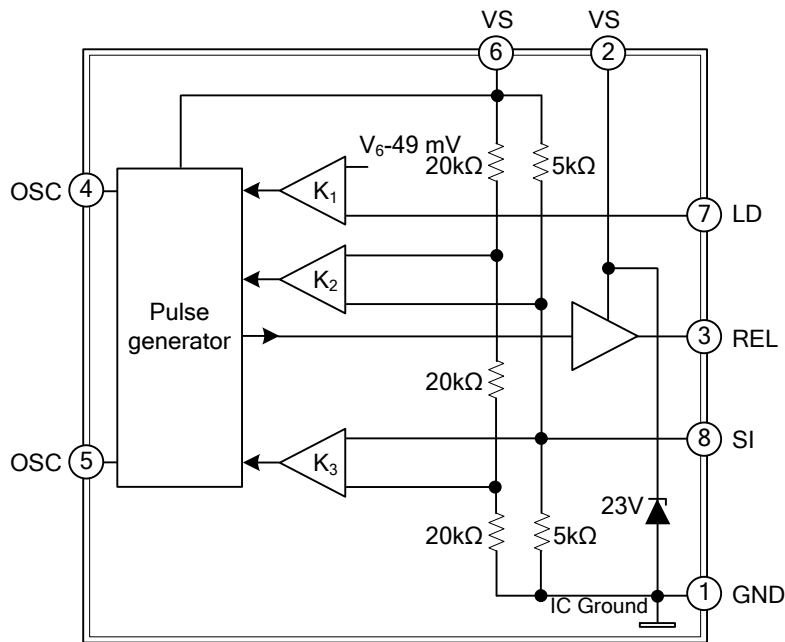

■ ABSOLUTE MAXIMUM RATING

Reference point Pin 1

PARAMETER		SYMBOL	RATINGS	UNIT	
Supply Voltage		Pin 2 and 6	V_S	16.5	V
Surge Forward Current	$t_p = 0.1 \text{ ms}$	Pin 2 and 6	I_{FSM}	1.5	A
	$t_p = 300 \text{ ms}$	Pin 2 and 6		1.0	A
	$t_p = 300 \text{ ms}$	Pin 8		50	mA
Output Current		Pin 3	I_O	0.3	A
Power Dissipation	$T_A = 95^\circ\text{C}$		P_D	340	mW
	$T_A = 60^\circ\text{C}$			560	mW
Ambient Temperature Range			T_A	-40~+95	$^\circ\text{C}$
Junction Temperature Range			T_J	150	$^\circ\text{C}$
Storage Temperature Range			T_{STG}	-55~+150	$^\circ\text{C}$

Note: Absolute maximum ratings are those values beyond which the device could be permanently damaged. Absolute maximum ratings are stress ratings only and functional device operation is not implied.

■ THERMAL RESISTANCE

PARAMETER	SYMBOL	RATINGS	UNIT
Junction to Ambient	θ_{JA}	160	$^\circ\text{C}/\text{W}$

■ ELECTRICAL CHARACTERISTICS

Typical values under normal operation in application circuit (see Figure 1), V_S (+49, Pin 2 and 6)=12V. Reference point ground (-31), $T_A=25^\circ\text{C}$, unless otherwise specified.

PARAMETER	SYMBOL	TEST CONDITIONS	MIN	TYP	MAX	UNIT
Supply Voltage Range	V_S	Pin 2 and 6	9		15	V
Supply Current	I_S	Dark phase, Pin 2 and 6		4.5	8	mA
		Bright phase, Pin 2 and 6		7.0	11	mA
Relay Control Output:	V_O	Pin 3			1.0	V
Saturation Voltage Reverse Current	I_O	$I_O=150\text{mA}$, $V_S=9\text{V}$			0.1	mA
Start Delay (Delay Time)	t_{on}	First bright phase			10	ms
Frequency Tolerance	Δf_1	Normal flashing	-5		+5	%
Bright Period	Δf_1	Basic frequency f_1	47		53	%
	Δf_2	Control frequency f_2	37		45	%
Frequency Increase	f_2	Lamp outage	$2.15 \times f_1$		$2.3 \times f_1$	Hz
Control Signal Threshold	V_{RS}	$V_S=15\text{V}$, Pin 7	50	53	57	mV
		$V_S=9\text{V}$, Pin 7	43	45	47	mV
		$V_S=12\text{V}$, Pin 7	47	49	51	mV
Leakage Resistance	R_P	49A to GND		4	5	k Ω
Lamp Load	P_L		1			W

■ TYPICAL APPLICATION CIRCUIT

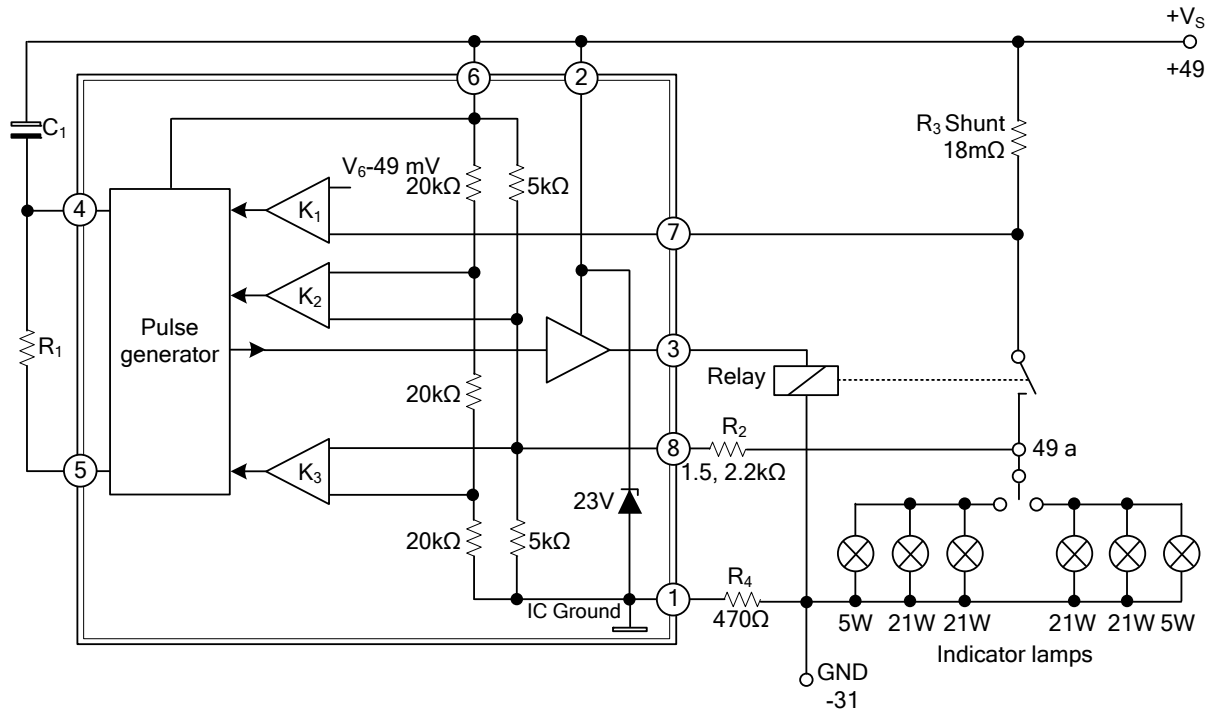

UTC assumes no responsibility for equipment failures that result from using products at values that exceed, even momentarily, rated values (such as maximum ratings, operating condition ranges, or other parameters) listed in products specifications of any and all UTC products described or contained herein. UTC products are not designed for use in life support appliances, devices or systems where malfunction of these products can be reasonably expected to result in personal injury. Reproduction in whole or in part is prohibited without the prior written consent of the copyright owner. The information presented in this document does not form part of any quotation or contract, is believed to be accurate and reliable and may be changed without notice.