

## 300mA, Micropower, VLDO Linear Regulator

### UM165XX SOT23-3

#### General Description

The UM165XX series are VLDO (very low dropout) linear regulators designed for low power portable applications. Typical output noise is only  $75\mu\text{V}_{\text{RMS}}$  and maximum dropout is just 90mV at the load current of 150mA. The internal P-channel MOSFET pass transistor requires no base current, allowing the device to draw only 100 $\mu\text{A}$  during normal operation at the maximum load current of 300mA.

Other features include high output voltage accuracy, excellent transient response, under voltage lockout, stability with ultralow ESR ceramic capacitors as small as 1 $\mu\text{F}$ , reverse-battery protection, short-circuit and thermal overload protection and output current limiting.

The UM165XX series are available in a low profile SOT23-3 package.

#### Applications

- Bluetooth/802.11 Cards
- PDAs and Notebook Computers
- Portable Instruments and Battery-Powered Systems
- Cellular Phones

#### Features

- Very Low Dropout: 90mV(max) at 150mA
- Maximum Input Voltage: 6.0V
- Low Noise:  $75\mu\text{V}_{\text{RMS}}$  (10Hz to 100kHz)
- $\pm 2\%$  Voltage Accuracy at 150mA
- Fast Transient Response
- Under Voltage Lockout
- Fixed Output Voltage:  
3.3V/3.0V/2.8V/2.7V/2.5V/1.8V/1.5V/1.3V/  
1.2V
- Output Current Limit
- Reverse-Battery Protection
- No Protection Diodes Needed
- Stable with 1 $\mu\text{F}$  Output Capacitor
- Short-Circuit and Thermal Overload Protection
- Low Profile SOT23-3 Package

#### Pin Configurations

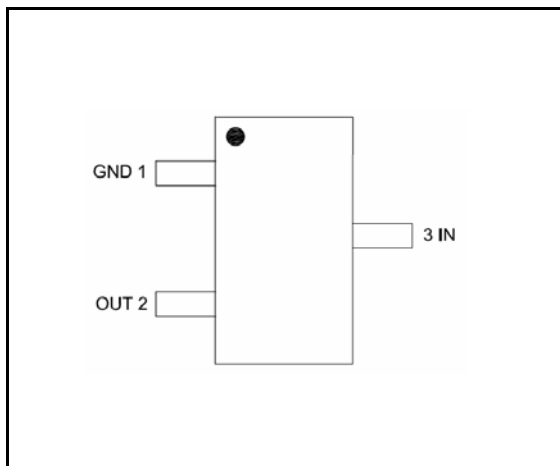

#### Top View

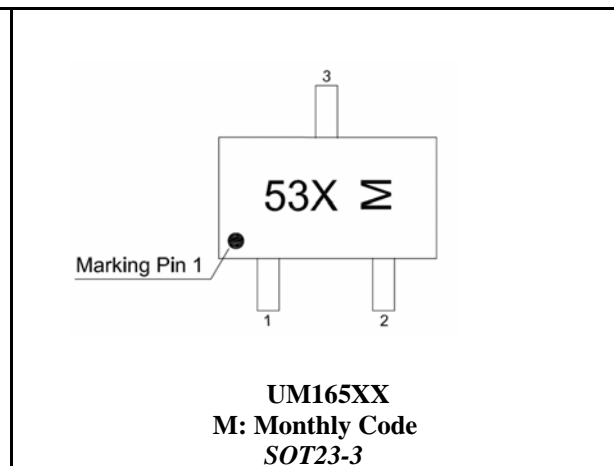

## Ordering Information

Part Number	Output Voltage	Packaging Type	Marking Code	Shipping Qty
UM165415	4.15V	SOT23-3	53S	3000pcs/7Inch Tape & Reel
UM16535	3.5V		53Z	
UM16533	3.3V		53U	
UM16530	3.0V		53R	
UM16528	2.8V		53Q	
UM16527	2.7V		53P	
UM16525	2.5V		53N	
UM16518	1.8V		53K	
UM16515	1.5V		53J	
UM16513	1.3V		53E	
UM16512	1.2V		53D	

## Pin Description

Pin Number	Symbol	Function
1	GND	Ground
2	OUT	Voltage Regulated Output
3	IN	Power Supply

## Absolute Maximum Ratings (Note 1)

Symbol	Parameter	Value	Unit
$V_{IN}$	Supply Voltage on IN Pin	-7.5 to +7.5	V
$V_{OUT}$	Voltage on OUT Pin	-0.3 to +7.5	V
	Output Short-Circuit Duration	Indefinite	
$T_J$	Operating Junction Temperature (Notes 2, 3)	-40 to +125	°C
$T_{STG}$	Storage Temperature Range	-65 to +150	°C
$T_L$	Lead Temperature for Soldering 10 seconds	+300	°C

Note 1: Absolute Maximum Ratings are those values beyond which the life of a device may be impaired.

Note 2: The UM165XX is tested and specified under pulse load conditions such that  $T_J \approx T_A$ . The device is guaranteed to meet performance specifications from 0°C to 70°C. Specifications over the -40°C to 125°C operating junction temperature range are assured by design, characterization and correlation with statistical process controls.

Note 3: This IC includes overtemperature protection that is intended to protect the device during momentary overload conditions. Junction temperature will exceed 125 °C when overtemperature protection is active. Continuous operation above the specified maximum operating junction temperature may impair device reliability.

## Electrical Characteristics

Symbol	Parameter	Test Conditions	Min	Typ	Max	Unit	
$V_{IN}$	Input Voltage Range		$V_{OUT}+$ $V_{DROP}$		6.0	V	
$V_{UVLO1}$ (Note1)	Input Under Voltage Lockout	$V_{IN}$ falling	2.0		2.6	V	
$V_{UVLO2}$ (Note2)	Input Under Voltage Lockout	$V_{IN}$ falling	2.1		2.3	V	
$I_Q$	Operating Quiescent Current	$I_{OUT}=0mA$		90		$\mu A$	
		$I_{OUT}=300mA$		100			
	ESD Rating	Human Body Mode	2			KV	
$I_{OUT}$	Output Current		300			mA	
	Output Voltage Accuracy	$1mA \leq I_{OUT} \leq 150mA$ , $T_A = +25^\circ C$	-1		+1	%	
		$1mA \leq I_{OUT} \leq 150mA$ , $T_A = -40^\circ C$ to $+85^\circ C$	-2		+2		
		$1mA \leq I_{OUT} \leq 300mA$ , $T_A = -40^\circ C$ to $+85^\circ C$	-2.5		+2.5		
$\Delta V_{DO}$	Dropout Voltage	$I_{OUT}=150mA$			90	mV	
$I_{LIMIT}$	Output Current Limit	$V_{IN} \geq 2.5V$	450			mA	
	Input Reverse Leakage Current (OUT to IN Leakage Current)	$V_{IN}=4V$ , $V_{OUT}=5.5V$ chip active		0.01	1.5	$\mu A$	
$T_{SHDN}$	Thermal-Shutdown Temperature			160		$^\circ C$	
$\Delta T_{SHDN}$	Thermal-Shutdown Hysteresis			20		$^\circ C$	
	Line Regulation	$V_{OUT}+1V \leq V_{IN} \leq V_{OUT}+2V$ $I_{OUT}=10mA$		0.09		%/V	
	Load Regulation	$V_{IN}=V_{OUT}+1V$ $1mA \leq I_{OUT} \leq 150mA$		0.2		%	
	Output Voltage Noise	10Hz to 100KHz $C_{IN}=0.1\mu F$ , $I_{OUT}=10mA$		75		$\mu V_{RMS}$	
PSRR	Power Supply Ripple Rejection	$V_{IN}=V_{OUT}+1V$ $I_{OUT}=100mA$	F=100Hz	70			dB
			F=1KHz	65			
			F=10KHz	50			
			F=100KHz	40			

Note1:  $V_{UVLO1}$  is measured for devices with  $V_{OUT} \geq 1.8V$ .

Note2:  $V_{UVLO2}$  is measured for devices with  $V_{OUT} \leq 1.5V$ .

Note3:  $\Delta V_{DO}$  just define for device with  $V_{OUT} \geq 2.5V$ .

## Pin Function

**GND (Pin1):** Ground and Heat Sink. Solder to a ground plane or large pad to maximize heat dissipation.

**OUT (Pin 2):** Voltage Regulated Output. The OUT pin supplies power to the load. A minimum output capacitor of 1 $\mu$ F is required to ensure stability. Larger output capacitors may be required for applications with large transient loads to limit peak voltage transients. See the Applications Information section for more information on output capacitance.

**IN (Pin 3):** Power for UM165XX and Load. Power is supplied to the devices through the IN pin. The IN pin should be locally bypassed to ground if the UM165XX series are more than a few inches away from another source of bulk capacitance. In general, the output impedance of a battery rises with frequency, so it is usually advisable to include an input bypass capacitor in battery-powered circuits. A capacitor in the range of 0.1 $\mu$ F to 1 $\mu$ F is usually sufficient. The UM165XX series are designed to withstand reverse voltages on the IN pin with respect to both ground and the output pin. In the case of a reversed input, which can happen if a battery is plugged in backwards, the UM165XX will act as if there is a large resistor in series with its input with only a small amount of current flow.

## Typical Application Circuit

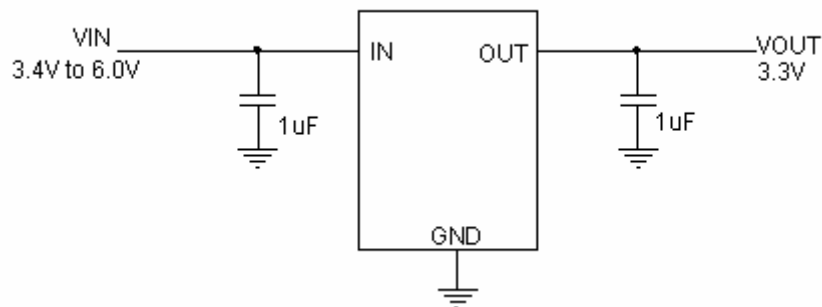

## Typical Performance Characteristics

**Quiescent Current vs Input Voltage**

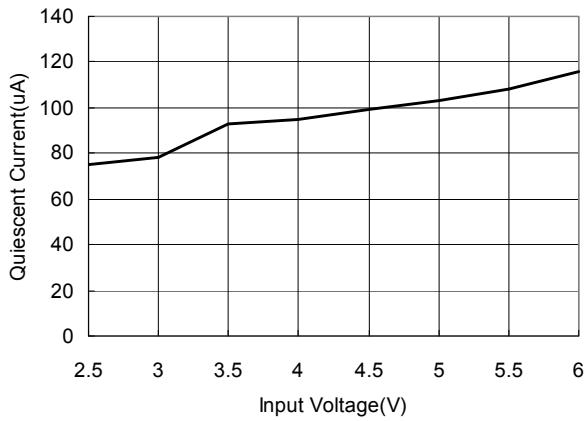

**Output Voltage vs Output Current**

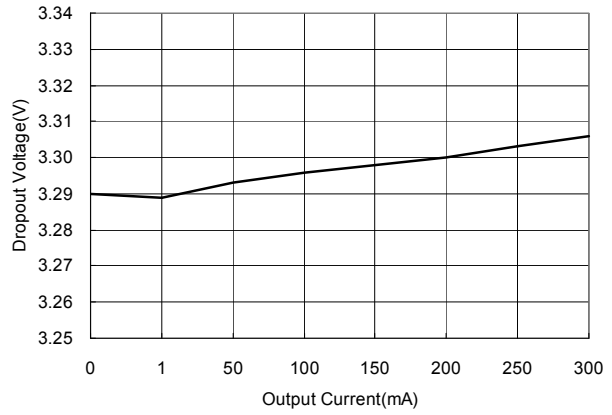

**Dropout Voltage vs Output Current**

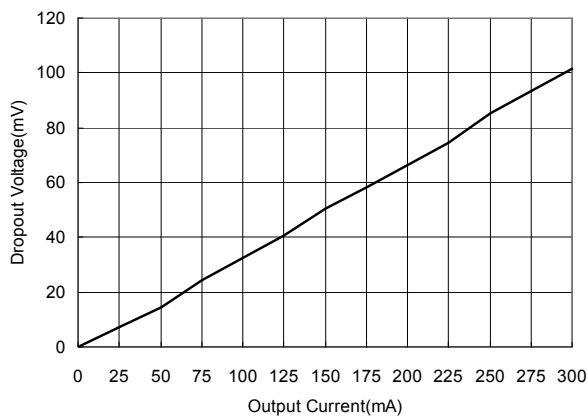

**Output Voltage vs Output Current**

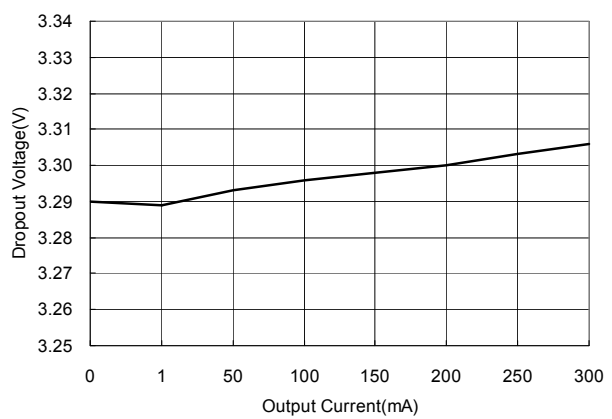

**Line Transient Response**

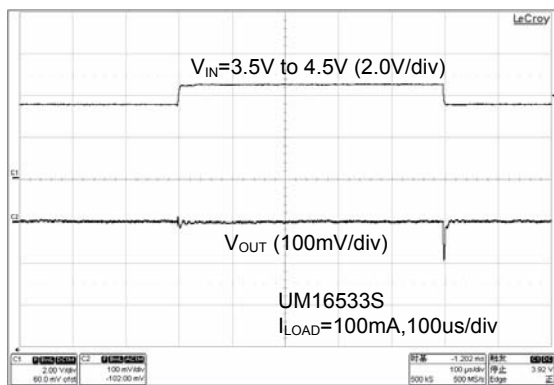

**Load Transient Response**

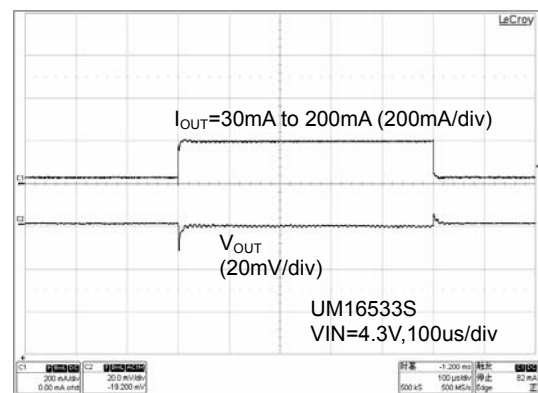

## Package Information

### UM165XX: SOT23-3

#### Outline Drawing

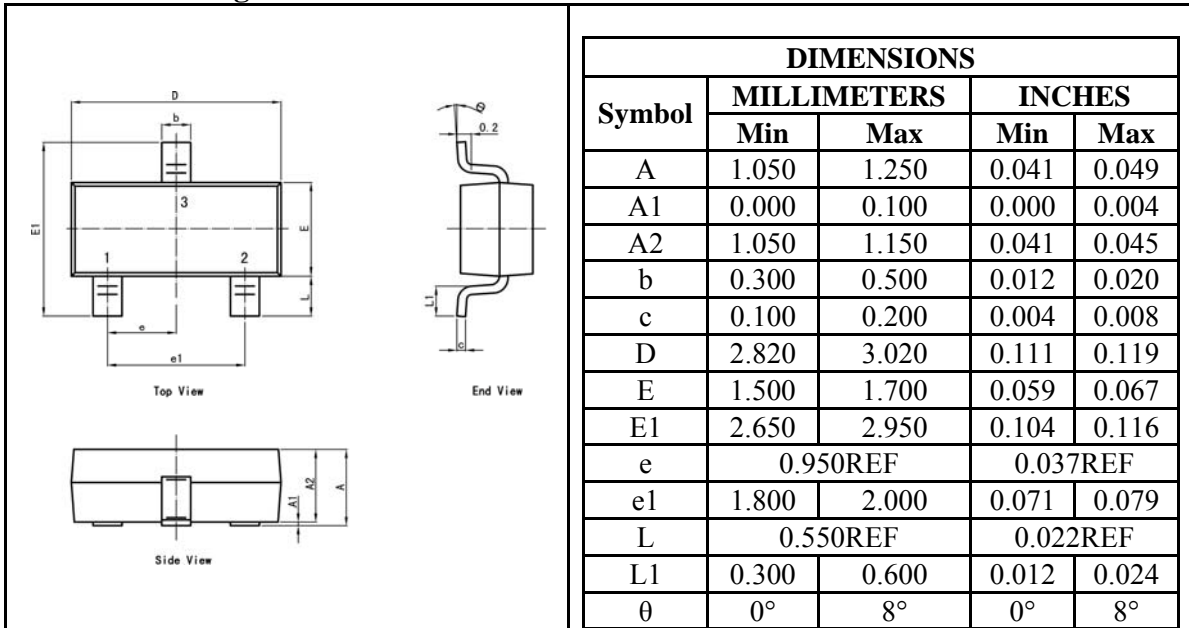

#### Land Pattern

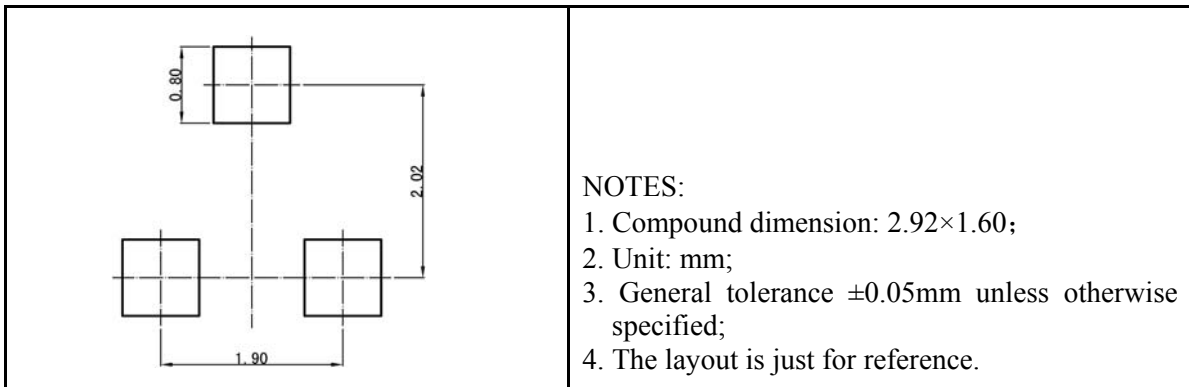

#### Tape and Reel Orientation

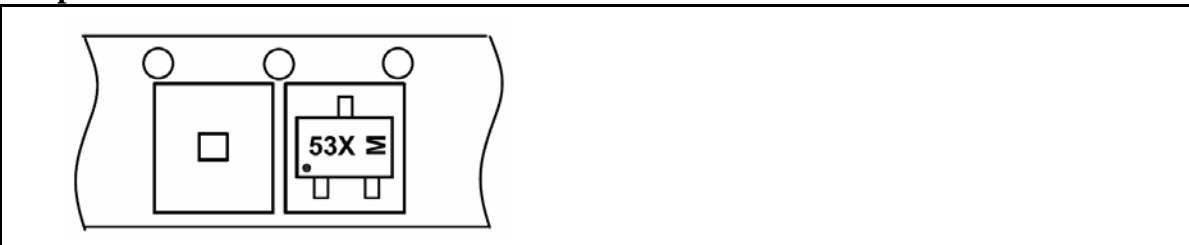

---

**IMPORTANT NOTICE**

The information in this document has been carefully reviewed and is believed to be accurate. Nonetheless, this document is subject to change without notice. Union assumes no responsibility for any inaccuracies that may be contained in this document, and makes no commitment to update or to keep current the contained information, or to notify a person or organization of any update. Union reserves the right to make changes, at any time, in order to improve reliability, function or design and to attempt to supply the best product possible.



Union Semiconductor, Inc

Add: 2F, No. 3, Lane 647 Songtao Road, Shanghai 201203

Tel: 021-51093966

Fax: 021-51026018

Website: [www.union-ic.com](http://www.union-ic.com)