

TGS 2603 - for detection of Odor and Air Contaminants

Features:

- * Low power consumption
- * High sensitivity to amine-series and sulfurous odor gases
- * High sensitivity to food odors
- * Long life and low cost
- * Uses simple electrical circuit

The sensing element is comprised of a metal oxide semiconductor layer formed on an alumina substrate of a sensing chip together with an integrated heater. In the presence of a detectable gas, the sensor's conductivity increases depending on the gas concentration in the air. A simple electrical circuit can convert the change in conductivity to an output signal which corresponds to the gas concentration.

The **TGS 2603** has high sensitivity to low concentrations of odorous gases such as amine-series and sulfurous odors generated from waste materials or spoiled foods such as fish.

By utilizing the change ratio of sensor resistance from the resistance in clean air as the relative response, human perception of air contaminants can be simulated and practical air quality control can be achieved.

The figure below represents typical sensitivity characteristics, all data having been gathered at standard test conditions (see reverse side of this sheet). The Y-axis is indicated as sensor resistance ratio (R_s/R_o) which is defined as follows:

- R_s = Sensor resistance in displayed gases at various concentrations
- R_o = Sensor resistance in fresh air

Sensitivity Characteristics:

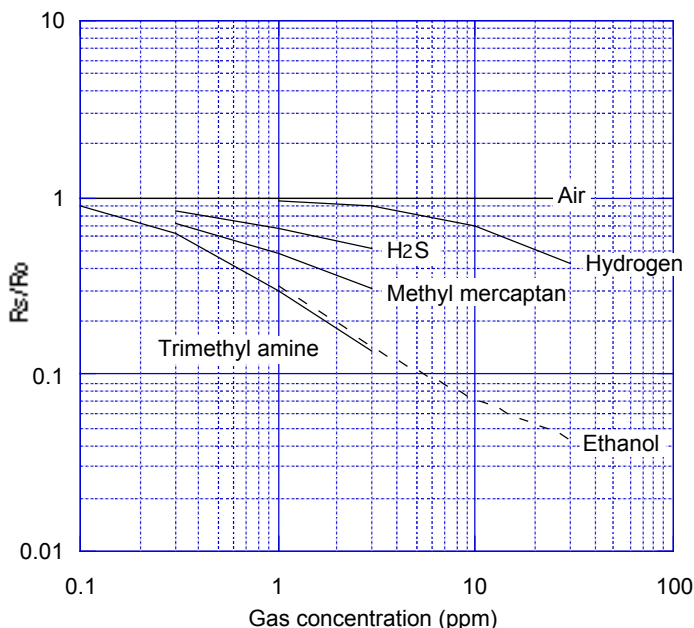

Applications:

- * Air cleaners
- * Ventilation control
- * Deodorizer control
- * Air quality monitors

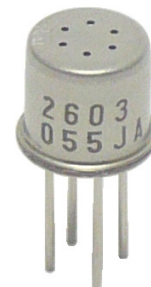

The figure below represents typical temperature dependency characteristics. Again, the Y-axis is indicated as sensor resistance ratio (R_s/R_o), defined as follows:

- R_s = Sensor resistance in fresh air at various temperatures
- R_o = Sensor resistance in fresh air at 20°C and 65% R.H.

Temperature Dependency:

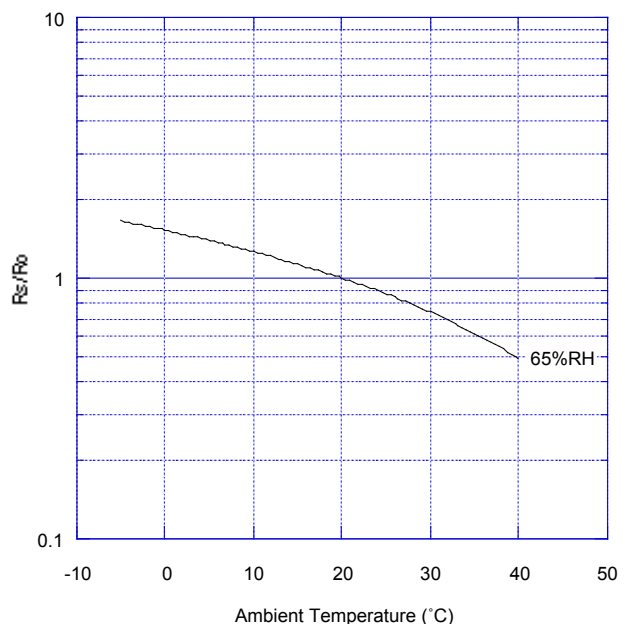

IMPORTANT NOTE: OPERATING CONDITIONS IN WHICH FIGARO SENSORS ARE USED WILL VARY WITH EACH CUSTOMER'S SPECIFIC APPLICATIONS. FIGARO STRONGLY RECOMMENDS CONSULTING OUR TECHNICAL STAFF BEFORE DEPLOYING FIGARO SENSORS IN YOUR APPLICATION AND, IN PARTICULAR, WHEN CUSTOMER'S TARGET GASES ARE NOT LISTED HEREIN. FIGARO CANNOT ASSUME ANY RESPONSIBILITY FOR ANY USE OF ITS SENSORS IN A PRODUCT OR APPLICATION FOR WHICH SENSOR HAS NOT BEEN SPECIFICALLY TESTED BY FIGARO.

Basic Measuring Circuit:

The sensor requires two voltage inputs: heater voltage (V_H) and circuit voltage (V_C). The heater voltage (V_H) is applied to the integrated heater in order to maintain the sensing element at a specific temperature which is optimal for sensing. Circuit voltage (V_C) is applied to allow measurement of voltage (V_{out}) across a load resistor (R_L) which is connected in series with the sensor. DC voltage is required for the circuit

voltage since the sensor has a polarity. A common power supply circuit can be used for both V_C and V_H to fulfill the sensor's electrical requirements. The value of the load resistor (R_L) should be chosen to optimize the alarm threshold value, keeping power consumption (P_S) of the semiconductor below a limit of 15mW. Power consumption (P_S) will be highest when the value of R_S is equal to R_L on exposure to gas.

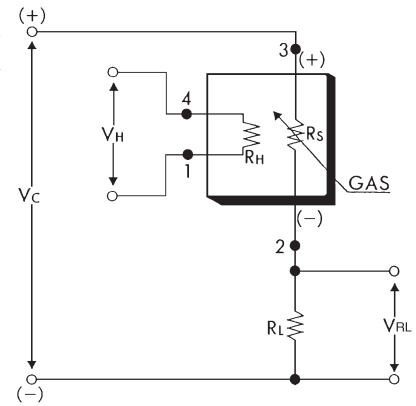

Specifications:

Model number		TGS2603	
Sensing element type		26-series	
Standard package		TO-5 metal can	
Target gases		Trimethylamine, H ₂ S, etc.	
Typical detection range		1 ~ 10ppm	
Standard circuit conditions	Heater voltage	V_H	5.0±0.2V AC/DC
	Circuit voltage	V_C	5.0±0.2V DC $P_S \leq 15mW$
	Load resistance	R_L	variable 0.45kΩ min.
Electrical characteristics under standard test conditions	Heater resistance	R_H	approx 67Ω at room temp. (typical)
	Heater current	I_H	48mA
	Heater power consumption	P_H	240mW $V_H=5.0V$ AC/DC
	Sensor resistance	R_S	20kΩ ~ 200kΩ in air
	Sensitivity (change ratio of R_S)		<0.5 $\frac{R_S(10ppm EtOH)}{R_S \text{ air}}$
Standard test conditions	Test gas conditions	normal air at 20±2°C, 65±5%RH	
	Circuit conditions	$V_C = 5.0 \pm 0.2V$ DC $V_H = 5.0 \pm 0.2V$ AC/DC	
	Conditioning period before test	96 hours or longer	

The value of power consumption (P_S) can be calculated by utilizing the following formula:

$$P_S = \frac{(V_C - V_{out})^2}{R_S}$$

Sensor resistance (R_S) is calculated with a measured value of V_{out} by using the following formula:

$$R_S = \frac{V_C \times R_L}{V_{out}} - R_L$$

All sensor characteristics shown in this brochure represent typical characteristics. Actual characteristics vary from sensor to sensor. The only characteristics warranted are those in the Specification table above.

Figaro reserves the right to make changes without notice to any products herein to improve reliability, functioning, or design.

Structure and Dimensions:

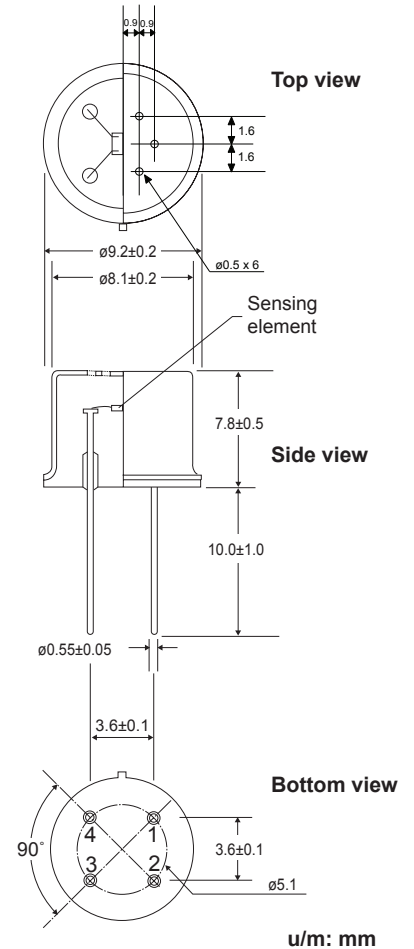

Pin connection:

- 1: Heater
- 2: Sensor electrode (-)
- 3: Sensor electrode (+)
- 4: Heater

FIGARO ENGINEERING INC.

1-5-11 Senba-nishi
Mino, Osaka 562-8505 JAPAN
Phone: (81)-72-728-2561
Fax: (81)-72-728-0467
www.figaro.co.jp
email: figaro@figaro.co.jp