



3.3 Volt CMOS 16-Bit Buffer/Line Driver

QS74FCT2X3244

FEATURES/BENEFITS

- Pin and function compatible to the QSFCT2X244
- Available in 40-pin QVSOP
- Undershoot clamp diodes on all inputs
- Ground bounce controlled outputs
- Low power QCMOS: 0.07 μ W typ static
- JEDEC low voltage spec compatible
- $I_{OL} = 24$ mA Com.
- TTL-compatible input and output levels
- Extended temperature -40°C to $+85^{\circ}\text{C}$
- 2.7V to 3.6V Supply Voltage

DESCRIPTION

The FCT2X3244 is a 16-bit buffer/line driver with three-state outputs that is ideal for driving high-capacitance loads as in memory address and data buses. All inputs have clamp diodes for undershoot noise suppression and all outputs have ground bounce suppression (see QSI Application Note AN-001). Control pins can be driven by 3.3V or 5V components. Ultra-low power QCMOS technology makes this product ideal for portable computing systems or communications devices.

FUNCTIONAL BLOCK DIAGRAM

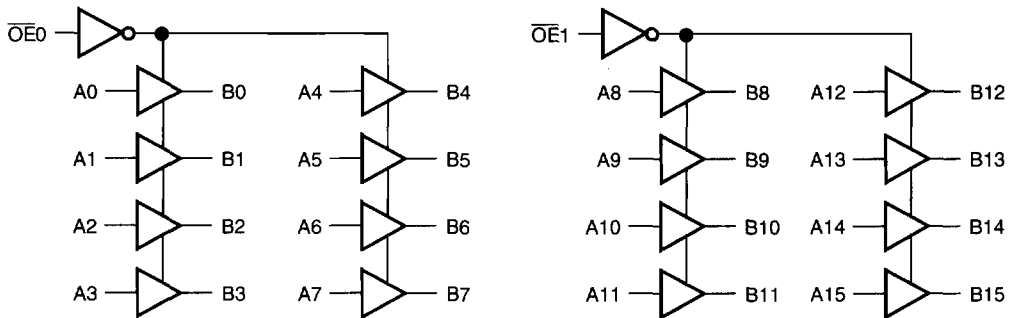

6

PIN CONFIGURATION
(All Pins Top View)

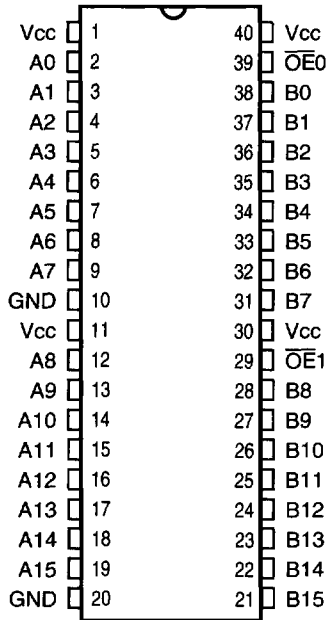

PIN DESCRIPTION

Name	I/O	Description
Ai	I/O	Data Bus A Inputs
Bi	I/O	Data Bus B Outputs
$\overline{OE}0$	I	Output Enables for A/B7-A/B0
$\overline{OE}1$	I	Output Enables for A/B15-A/B8

FUNCTION TABLE

$\overline{OE}n$	Input A	Output B
H	X	Hi-Z
L	L	L
L	H	H

ABSOLUTE MAXIMUM RATINGS

Supply Voltage to Ground	-0.5V to +4.6V
DC Input/Output Voltage	-0.5V to Vcc + 0.5V
DC Control Pin Voltage V_{IN}	-0.5V +7.0V
AC Input Voltage (for a pulse width ≤ 20 ns)	-3.0V
DC Input Diode Current with $V_{IN} < 0$	± 20 mA
DC Output Diode Current with $V_{OUT} < 0$	± 50 mA
DC Output Current Max. Sink Current/Pin	± 60 mA
Maximum Power Dissipation	0.5 watts
T_{STG} Storage Temperature	-65° to +150°C

Note: Stresses greater than those listed under ABSOLUTE MAXIMUM RATINGS may cause permanent damage to this device resulting in functional or reliability type failures.

CAPACITANCE

$T_A = 25^\circ\text{C}$, $f = 1\text{ MHz}$, $V_{IN} = 0\text{V}$, $V_{OUT} = 0\text{V}$

Pins	QVSOP Typ	Unit
1, 11, 29, 39	4	pF
2-9, 12-19, 21-28, 31-38	8	pF

Note: Capacitance is characterized but not tested.

RECOMMENDED OPERATING CONDITIONS

Symbol	Description	Min	Max	Unit
V _{CC}	Supply Voltage	2.7	3.6	V
V _{IN}	Input Voltage	0	V _{CC}	V
V _{OUT}	Output Voltage	0	V _{CC}	V
T _A	Ambient Operating Temperature	-40	+85	°C
Δt/ΔV	Input Transition Rise or Fall Rate ⁽¹⁾	0	8	ns/V

Notes:

1. As measured between 0.8V and 2V.

DC ELECTRICAL CHARACTERISTICS OVER OPERATING RANGE

Recommended operating conditions apply unless otherwise specified.

Symbol	Parameter	Test Conditions	Min	Typ ⁽¹⁾	Max	Unit
V _{IH}	Input HIGH Voltage	Input Pins	2.0	—	5.5	V
		I/O Pins	2.0	—	V _{CC} +0.5	V
V _{IL}	Input LOW Voltage	Input Pins	-0.5	—	0.8	V
ΔV _T	Input Hysteresis	V _{TLH} - V _{THL} for All Inputs	—	0.2	—	V
I _{IH} I _{IL}	Input Current Input HIGH or LOW	V _{CC} = Max., 0 ≤ V _{IN} < V _{CC}	—	—	1	μA
I _{oz}	Off-State Output Current (Hi-Z)	V _{CC} = Max., 0 ≤ V _{IN} ≤ V _{CC}	—	—	5	μA
I _{os}	Short Circuit Current	V _{CC} = Max., V _{OUT} = GND ^(2,3)	-60	—	-225	mA
V _{IC}	Input Clamp Voltage	V _{CC} = Min., I _{IN} = -18 mA ⁽³⁾	—	-0.7	—	V
V _{OH}	Output HIGH Voltage	V _I = V _{IH} or V _{IL} , V _{CC} = Min, I _{OH} = -100 μA	V _{CC} -0.2	—	—	V
		V _I = V _{IH} or V _{IL} , V _{CC} = 3V, I _{OH} = -8 mA	2.4	—	—	
V _{OL}	Output LOW Voltage	V _I = V _{IH} or V _{IL} , V _{CC} = Min, I _{OL} = 100 μA	—	—	0.2	V
		V _I = V _{IH} or V _{IL} , V _{CC} = 3V, I _{OL} = 16 mA	—	—	0.4	V
		V _I = V _{IH} or V _{IL} , V _{CC} = 3V, I _{OL} = 24 mA	—	—	0.5	V

Notes:

1. Typical values indicate V_{CC} = 3.3V and T_A = 25°C.
2. Not more than one output should be shorted and the duration is ≤1 second.
3. These parameters are guaranteed by design but not tested.



POWER SUPPLY CHARACTERISTICS

Symbol	Parameter	Test Conditions ⁽¹⁾	Min	Typ	Max	Unit
I _{CC}	Quiescent Power Supply Current	V _{CC} = Max., freq = 0 0V ≤ V _{IN} ≤ 0.2V or V _{CC} -0.2V ≤ V _{IN} ≤ V _{CC}	—	0.02	40	μA
ΔI _{CC}	Supply Current per Input @ TTL HIGH	V _{CC} = Max., freq = 0, V _{IN} = V _{CC} - 0.6V	—	1.0	20	μA
Q _{CCD}	Supply Current per Input per MHz	V _{CC} = Max., Outputs Open and Enabled One Bit Toggling @ 50% Duty Cycle Other Inputs at GND or V _{CC} ^(2,3)	—	40	85	μA/MHz

Notes:

- For conditions shown as Min. or Max., use the appropriate values specified under DC specifications.
- Q_{CCD} is a measurement of device power consumption only and does not include power to drive load capacitance or tester capacitance. This parameter is guaranteed by design but not tested.
- I_C can be computed using the above parameters as explained in the Technical Overview section.

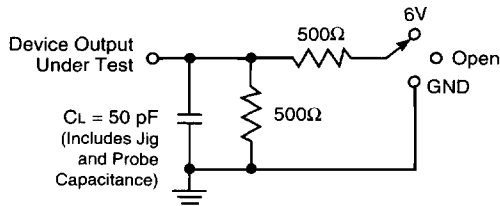

Test	Switch
t _{PHL} /t _{PLH}	Open
t _{PZL} /t _{PLZ}	6V
t _{PZH} /t _{PHZ}	GND

Load Circuit for Outputs

Notes

- Input pulse characteristics: 0V to 2.7V, t_r = t_f = 2.5 ns (10% to 90%), transition measured at 1.5V, pulse generator Z_{OUT} = 50Ω.

SWITCHING CHARACTERISTICS OVER OPERATING RANGE

Commercial T_A = 0°C to 70°C, V_{CC} = 3.3V ± 0.3V

C_{LOAD} = 50 pF, R_{LOAD} = 500Ω unless otherwise noted.

Symbol	Description ⁽¹⁾	2X3244		2X3244A		Unit
		Min	Max	Min	Max	
t _{PLH} t _{PHL}	Propagation Delay A _i to B _i	1.5	6.5	1.5	4.8	ns
t _{PZH} t _{PZL}	Output Enable \overline{OE} to B _i	1.5	8	1.5	6.2	ns
t _{PLZ} t _{PHZ}	Disable Time ⁽²⁾	1.5	7	1.5	5.6	ns

Notes:

- Minimums guaranteed but not tested.
- This parameter is guaranteed by design but not tested.
- See Test Circuit and Waveforms.