

File No	RDPS-MF055	
Revision	R0	
System Application	Mirco Filter For ADSL CPE Side	
Product Type	Micro filter	
Product Name	MF601BE	
Date	Sep. 30 th , 2002	
Issued By	Bert Lin - Design Engineer, R&D_1	
	bert@ycl.com.tw	
Approved By	Roger Wu - Manager, R&D_1	
	roger@ycl.com.tw	
Issued Date		



YCL Electronics Co., Ltd.

No.95, Feng Jen Road, Feng Shan City, Kaohsiung County, Taiwan, R.O.C.

This controlled document is the property of YCL Electronics Co., Ltd. Any duplication reproduction or transmission by unauthorized parties without the prior written permission of YCL Electronics Co., Ltd. is prohibited.

Table of contents

Item	Description	Page
1.	Introduction	3
2.	Compatibility	3
3.	References	4
4.	Abbreviations	4
5.	Technical requirements	5
	5.1. Schematic	5
	5.2. ZHP-r definition	5
	5.3. Electrical specification	6
	5.4. DC characteristics	8
	5.5. Test methods	8
	5.5.1 . Off-hook insertion loss	8
	5.5.2 . Return loss	9
	5.5.2.1. Complex* return loss with ATU-R	9
	5.5.2.2. 600 ohm return loss with ATU-R	9
6	Environmental condition	10
	6.1. Resistibility to overvoltage and overcurrents	10
	6.2. Climatic condition	10
	6.2.1. Operating temperature	10
	6.2.2. Storage and transport	10
	6.2.3. Operating humidity	10
7	Reliability conditions	10
	7.1. Thermal shock	10
	7.2. Temperature humidity exposure	10
	7.3. Vibration test	10
8.	Mechanical conditions	11
	8.1. Mechanical	11
	8.2. Connector information	11

1. Introduction:

The in-Line Micro filter has been specifically designed to implement the functionality of low pass filter in G.Lite system. G.Lite technology is similar to full rate ADSL in using DMT technology but operates at a lower data rate of up to 1.5Mbps downstream and 512Kbps upstream, depending on line conditions and lengths. ADSL Lite is proposed as a lower speed version of ADSL that will eliminate the need for telecom to install and maintain a premises based POTS splitter. It was found necessary to include one or more low pass filters in series with the POTS terminals in order to reliably achieve maximum data rates.

For POTS voice band service, the low pass filter provides protection from ADSL signal which may impact through non-line or other effects remote devices (handset, fax, voice band modem etc) and central office operation. For ADSL signal, it also provides protection from the high frequency transient and impedance effect that occur during POTS operation (ringing transients, on-hook, off-hook transient and so on).

Because the POTS splitter connects directly to the subscriber loop media, it must also provide some protection for externally induced line hits or faults which could damage any attached equipment or endanger humans interacting with the installed equipment. The circuit protection will be provided mostly by standard central office line protection means and additional protection measures built into pots splitter to protect against line overstress which could damage the splitter itself.

2. Reference:

Ref. 1 :	ETS 300 001	Attachment to Public Switched Telephone Network
Ref. 2 :	ANSI T1E1.4 G.992.2	Network and Customer Installation Interface
Ref. 3 :	ITU-T K20	Resistibility of telecommunication switching Equipment to overvoltages and overcurrents
Ref. 4 :	ITU-T K21	Resistibility of subscribers terminal to overvoltage and overcurrents

3. Abbreviations:

ADSL	Asymmetric Digital Subscriber Line
CO	Central Office
CPE	Customer Premise Equipment.
POTS	Plain Old Telephone Service
RT	Remote Terminal
ADSL-NT	Network termination of ADSL

4. Abbreviations:

ADSL	Asymmetric Digital Subscriber Line
CO	Central Office
CPE	Customer Premise Equipment.
POTS	Plain Old Telephone Service
RT	Remote Terminal
DSL-NT	Network Termination of ADSL

5. Technical requirements:

5.1. Schematic:

The following drawing illustrates the schematic of this product.

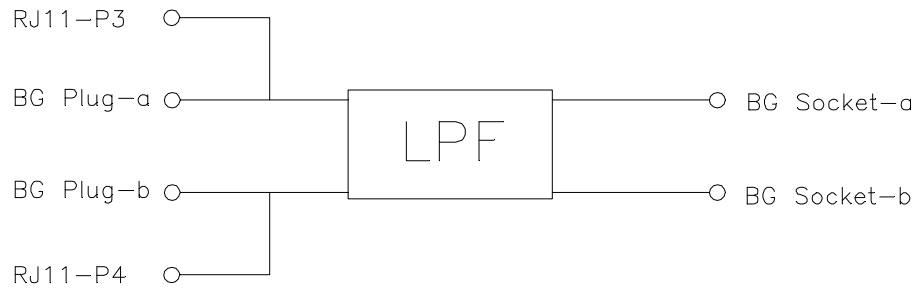

5.2. ZHP-r definition:

To facilitate testing of the Single In-Line filter independently of the actual modem or specific vendor, ZHP-r is defined to allow proper termination of the ADSL port during voice band testing. The ZHP-r is valid only for voice band frequency. The combination of capacitors in the ZHP-r is only representative. The input shall be 27 nF however derived. ZHP-r equivalent circuit is shown below.

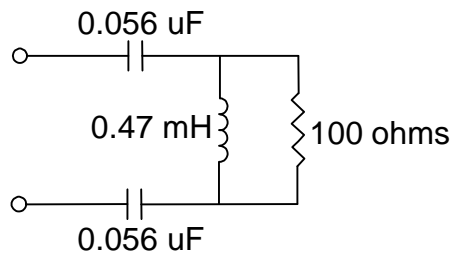

5.3. Electrical specification:

The low pass filter shall satisfy the following parametric limits shown in this table across the Line side of this device.

Splitter parameters	Electrical requirements	
	Range	Values
Splitter bandwidth		DC to 4 kHz
Nominal voice band		0.3 kHz to 3.4 kHz
Ringing frequency		15.3 Hz to 68 Hz
ADSL band		30 kHz to 1104 kHz
Line Impedance Z_L	300 Hz to 3.4 kHz	600 ohms
Line Impedance Z_{NL-r}	300 Hz to 3.4 kHz	1330 ohm // (348 ohm + 0.1 μ F)
Modem impedance	30 kHz to 1104 kHz	100 ohms
Operation voltage voice band		
Nominal signal		21 mVpp to 5.4 Vpp
Ringing signal		40 Vrms to 150 Vrms (113 Vpp to 424 Vpp)
DC voltage		0 V to 105 V
Max. AC voltage		150 Vrms with -105 VDC offset
Max. differential		320 V
Operation current voice band		
Loop current		< 100 mA
DC resistance		
DC resistance	Tip to Tip and Ring to Ring	< 50 ohms
Isolation resistance	Tip to Ring	> 10 Mohms
Differential input blocking impedance		
Line side	20 kHz	> 2 kohms
	30 kHz	> 3 kohms
	5 MHz to 10 MHz	> 2 kohms
	10 MHz to 400 MHz	N / A
Voice band characteristics		
Insertion loss between 600 ohms resistive single filter	1004 Hz	< 0.7 dB
With 5 filters	1004 Hz	< 1.0 dB

Splitter parameters	Electrical requirements	
	Range	Values
Attenuation distortion between 600 ohms resistive single filter	200 to 3.4 kHz	< 1.0 dB
Attenuation distortion between 600 ohms resistive with 5 filters	200 to 3.4 kHz	< 5 dB
600 ohms return loss single filter	SRL-L	> 23 dB
	ERL	> 23 dB
	SRL-H	> 23 dB
600 ohms return loss with 5 filters	SRL-L	> 20 dB
	ERL	> 13.5 dB
	SRL-H	> 7 dB
Complex* ZNL-r Return loss single filter	SRL-L	> 26.5 dB
	ERL	> 17 dB
	SRL-H	> 9 dB
Complex* ZNL-r return loss with 5 filters	SRL-L	> 15 dB
	ERL	> 8 dB
	SRL-H	> 2 dB
* 1330 ohms in parallel with the series connection of a 348 ohms resistor and a 100 nF capacitor		
Longitudinal conversion loss (LCL)	200 Hz to 1 kHz	> 58 dB
	1 kHz to 3 kHz	> 53 dB
Delay distortion	200Hz to 4 kHz	< 100 μ s
Inter-Modulation distortion	2nd	> 57 dB
	3rd	> 60 dB
ADSL band characteristics		
Common mode rejection	40 kHz	> 45 dB
	1.1 MHz	> 45 dB
ADSL band attenuation	30 kHz	> 24 dB
	1 MHz	> 65 dB

5.4. DC characteristics :

All requirements of this specification can be met in the presence of all POTS loop currents from 0 mA to 100 mA. This Single In-Line filter can pass POTS tip-to-ring DC voltages of 0 V to 105 V and ringing signals of 40 Vrms to 150 Vrms at any frequencies from 15.3 Hz to 68 Hz superimposed on DC voltages in the range from 0 V to 105 V. The DC resistance from tip-to-ring at the line port interface with the phone interface shorted, shall be less than or equal to 50 ohms for one filter. The DC resistance from tip-to-ground and from ring-to-ground at the Phone interface with the Line interface open shall be greater than or equal to 10 Megohms. The ground point shall be local building or green wire ground. As an objective, the DC resistance should exceed 10 MΩ.

5.5. Test methods :

5.5.1. Off-hook insertion loss :

The insertion loss of a device connected into a given transmission system is defined as the ratio, expressed in dB, of the load power available (before and after insertion) delivered to the output network beyond the point of insertion at a given frequency. In general, the insertion loss is defined as the ratio, expressed in dB of the power delivered to a load with the circuit in place and the power delivered to a load without the circuit in place. The added insertion loss shall be measured using the test up in figure 2. For measuring POTS band insertion loss for single filter module also for single filter with four added parallel load filters. General Insertion loss equation can be expressed as follows.

Insertion loss = $20 \log | V2 / V1 |$ dB where

V1 = the measured voltage value of load without LPF in circuit.

V2 = the measured voltage value of load with LPF in circuit.

The test setup is shown in drawing below.

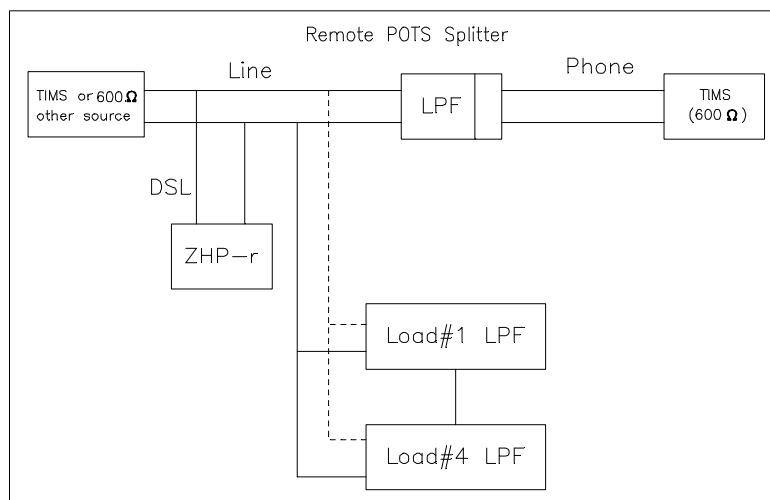

Figure 2.

5.5.2. Return loss:

Return loss measure the amount of energy that is lost due to reflection which resulted from impedance mismatching at the interface. Return loss is essentially defined as the ratio of the power incident upon a given transmission system to the power reflected caused by impedance mismatch with respect to reference impedance at the interface between source and device. Return loss figure are a function of the impedance of the circuit involved and are therefore frequency dependent. These impedance must be closely maintained in order to reduce the possibility of undesirable reflection and echoes which in long distance circuit the telephone user or destroy the data being sent. To perform the return loss test, open, short, load calibration must be done prior measurement while the LCR impedance analyzer being selected in impedance mode. Return loss is general expressed in decibels. General return loss equation is as follows.

$$\text{Return loss} = 20 \log \left| \frac{Z_L + Z_M}{Z_L - Z_M} \right| \text{ dB}$$

Where Z_L = the reference impedance

Z_M = the measured impedance

The test setup is shown in drawing below.

5.5.2.1. Complex* return loss with ATU-R :

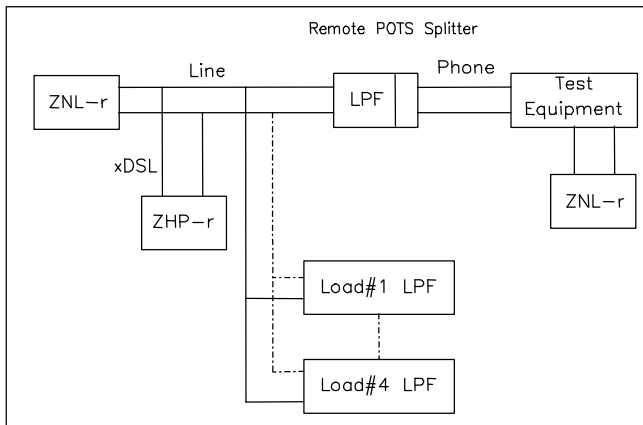

ZNL-r definition:

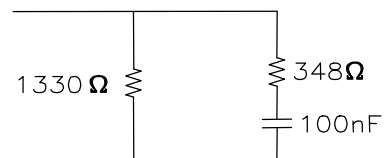

Figure 3.

5.5.2.2. 600 ohm return loss with ATU-R :

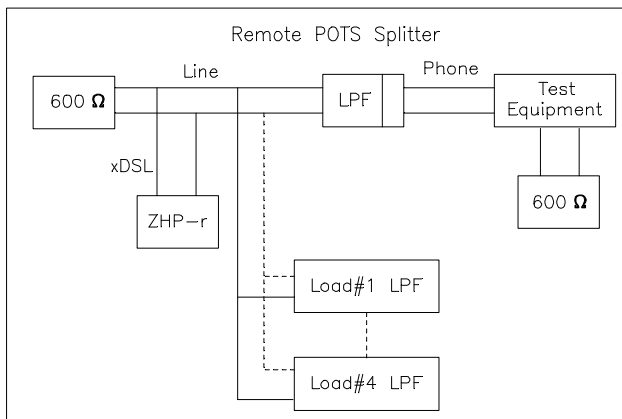

Figure 4.

6. Environmental conditions:

6.1. Resistibility to overvoltages and overcurrents:

The splitter has to comply with requirements as per ITU-T K.21.

6.2. Climatic conditions:

6.2.1. Operating temperature:

Application indoor
Long time operation guarantee temperature (5 to 40 °C)
Short time operation guarantee temperature (0 to 50 °C)
(According to ETS 300 019, class 3.2)

6.2.2. Storage and transport:

Low ambient temperature - 20 °C
High ambient temperature +85 °C
(According to MIL-STD-202 method 107)

6.2.3. Operation humidity:

Long time operation guarantee humidity (5 to 85 %)
Short time operation guarantee humidity (5 to 90 %)
Short time : within 72 continuous hours and 15 days in a year

7. Reliability conditions:

7.1. Thermal shock :

Temperature from -20 °C to +85 °C for 5 cycles
(According to MIL-STD-202 , method 107)

7.2. Temperature humidity exposure :

+50 °C /95RH , 96hrs
(According to MIL-STD-202 , method 103)

7.3. Vibration test :

Random vibration , frequency 5-500Hz , sweep time :1 hr / axis /
Force : 2.4grams (According to MIL-STD-202 , method 204)

8. Mechanical conditions :

8.1. Mechanical :

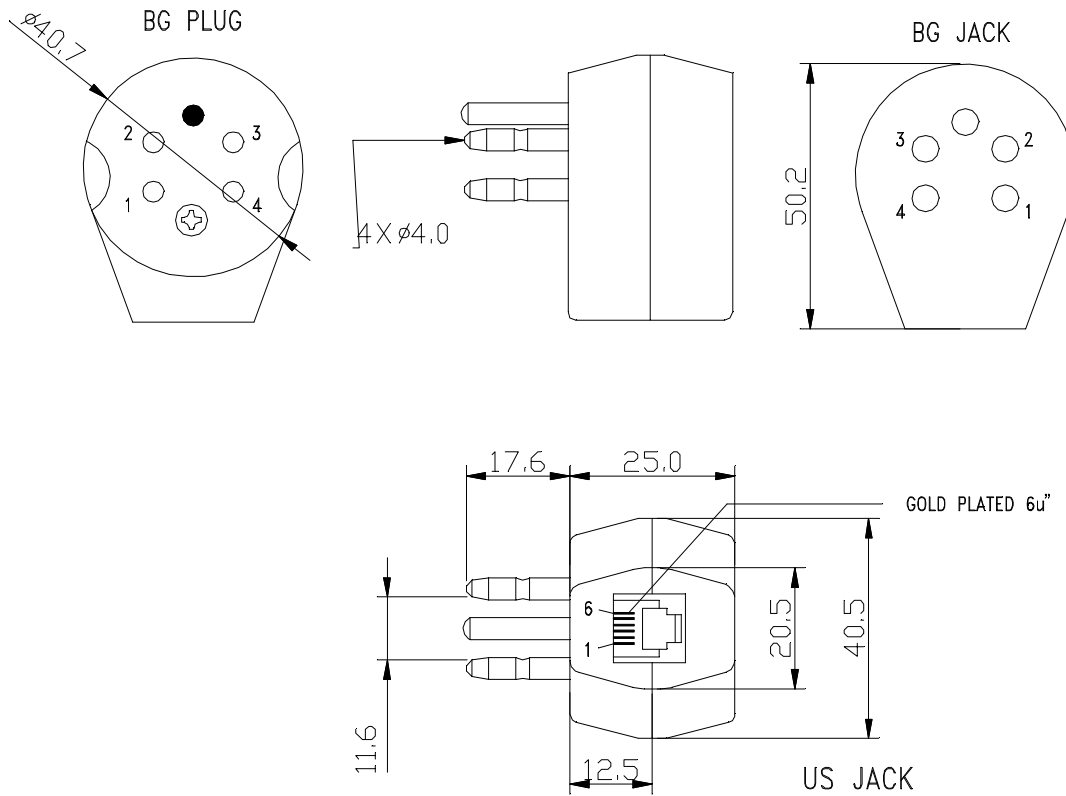

Note :
Unit : mm

8.2. Connector information :

Position	Type	Tip	Ring
Phone	BG Socket	3	4
Line	BG Plug	3	4
ADSL	RJ11 Jack	P3	P4