

**NOTES:**

1. FINISH: Parts shall have a smooth appearance, min. 600 surface finish, with no gates and all flash removed
2. U.S. & Foreign Pat. Issued & Pend.

REVISIONS				
ECN #	REV	DESCRIPTION	DATE	INITIALS
	N/A	INITIAL RELEASE	10/25/85	JS
	001	REVISED PER ECR1110AZ01	2/8/10	KH
145	002	CHANGE IN MATERIAL	7/12/10	KH

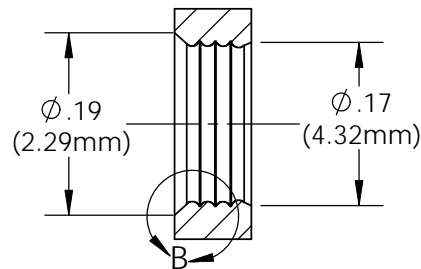
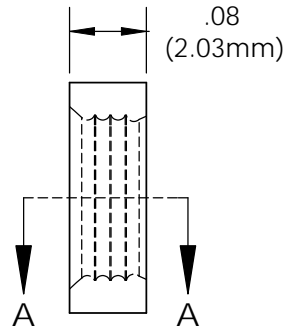

SECTION A-A

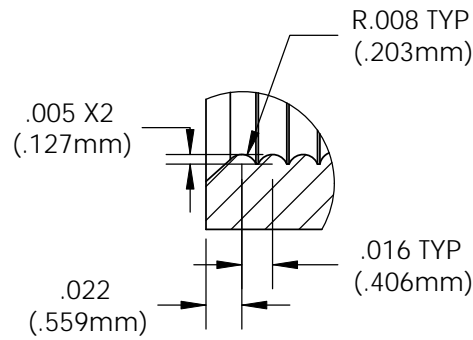
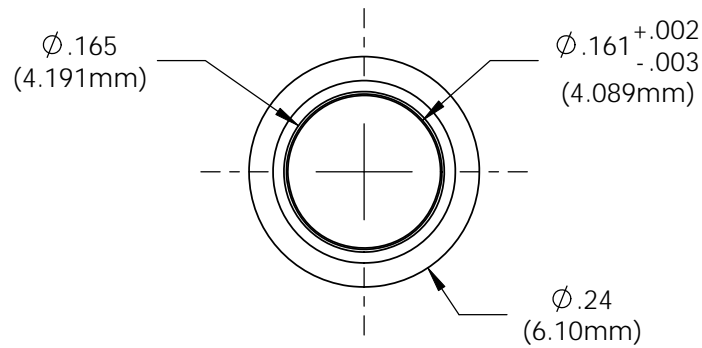

DETAIL B  
SCALE 10 : 1



ISOMETRIC VIEW

UNLESS OTHERWISE SPECIFIED DIMENSIONS ARE IN INCHES: ANGLES ± 1' DECIMALS .X ± .020 .XX ± .010 .XXX ± .005 FINISH .XXX ± .005 BREAK ALL CORNERS AND SHARP EDGES .050 MAX		MATERIAL 50% PRO-FAX SG702 (BLACK) 50% ELASTOCON 8068		VISUAL COMMUNICATIONS COMPANY 190 Bosstick Boulevard, Suite 101 San Marcos, CA 92069 USA Phone (760) 560-1300 Fax (760) 560-1301 email vccsales@vcclite.com	
THIRD ANGLE PROJECTION		FINISH SEE NOTES		TITLE: CLIPLITE RNG 132	
PROPRIETARY AND CONFIDENTIAL THE INFORMATION CONTAINED IN THIS DRAWING IS THE SOLE PROPERTY OF VISUAL COMMUNICATIONS COMPANY, INC. ANY REPRODUCTION IN PART OR AS A WHOLE WITHOUT THE WRITTEN PERMISSION OF VISUAL COMMUNICATIONS COMPANY, INC. IS PROHIBITED.		APPROVALS	DATE	SIZE <b>A</b>	DWG. NO. <b>RNG 132_E</b>
		DRAWN K.HOWARD	2/8/10	REV <b>002</b>	
		CHECKED DPZ	2/22/10	SCALE: 5:1	
		DO NOT SCALE DRAWING		SHEET 1 OF 1	