

Silicon N-P-N Transistors

Complementary to the D45VH Series

Features:

- Fast Switching $t_s \leq 700 \text{ ns}$ resistive
 $t_f \leq 200 \text{ ns}$
- Low $V_{CE(sat)} \leq 0.4V @ I_C = 8A$

The D44VH series of silicon n-p-n power transistors are especially designed for use in switching circuits such as switching regulators, high-frequency inverters/converters, and other applications where very fast switching times and low-saturation voltages are necessary. These devices are tested for parameters that relate directly to the design of high-power switching circuits. Switching times, saturation voltages, and leakage currents are specified at 100°C to provide information necessary for worst-case design.

TERMINAL DESIGNATIONS

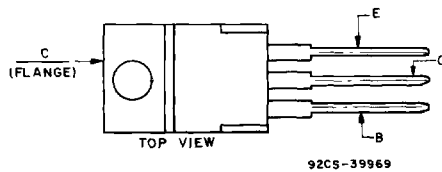

JEDEC TO-220AB

MAXIMUM RATINGS (T_A = 25° C) (unless otherwise specified)

RATING	SYMBOL	D44VH1	D44VH4	D44VH7	D44VH10	UNIT
Collector-Emitter Voltage	V _{CEO(sus)}	30	45	60	80	V
Collector-Emitter Voltage	V _{CEX}	40	55	70	90	V
Collector-Emitter Voltage	V _{CEV}	50	65	80	100	V
Emitter Base Voltage	V _{EBO}	7				V
Collector Current — Continuous	I _C	15				A
— Peak (1)	I _{CM}	20				
Base Current — Continuous	I _B	5				A
— Peak (1)	I _{BM}	10				
Total Power Dissipation @ T _C = 25°C	P _D	83				Watts
Derate above 25°C		33				W/°C
		0.67				
Operating and Storage Junction Temperature Range	T _J , T _{STG}	-55 to +150				°C

THERMAL CHARACTERISTICS

CHARACTERISTICS	SYMBOL	MAX	UNIT
Thermal Resistance, Junction to Case	R _{θJC}	1.5	°C/W
Thermal Resistance, Junction to Ambient	R _{θJA}	74	°C/W
Maximum Lead Temperature for Soldering Purposes: 1/8" from Case for 5 Seconds	T _L	235	°C

(1) Pulse measurement condition PW ≤ 6.0 ms. See Figure 14.

ELECTRICAL CHARACTERISTICS (T_C = 25°C) (unless otherwise specified)

CHARACTERISTICS	SYMBOL	MIN	MAX	UNIT
OFF CHARACTERISTICS⁽¹⁾				
Collector-Emitter Sustaining Voltage ⁽¹⁾ (I _C = 100mA, I _B = 0) D44VH1 D44VH4 D44VH7 D44VH10	V _{CEO(sus)}	30 45 60 80	—	V
Collector-Emitter Voltage ⁽²⁾ (I _C = 1A, V _{CLAMP} = Rated V _{CEX} , T _C = 100°C) D44VH1 D44VH4 D44VH7 D44VH10	V _{CEX}	40 55 65 90	—	V
Collector Cutoff Current (V _{CEV} = Rated Value, V _{BE(off)} = -4.0V) (V _{CEV} = Rated Value, V _{BE(off)} = -4.0V, T _C = 100°C)	I _{CEV}	—	10 100	μA
Collector Cutoff Current (V _{CE} = Rated V _{CEV} , R _{BE} = 50 Ω, T _C = 100°C)	I _{CER}	—	100	μA
Emitter Cutoff Current (V _{EB} = 7V, I _C = 0)	I _{EBO}	—	10	μA

SECOND BREAKDOWN

Second Breakdown with Base Forward Biased	F _{BSOA}	SEE FIGURE 7
Second Breakdown with Base Reverse Biased	R _{BSOA}	SEE FIGURE 8

ON CHARACTERISTICS⁽¹⁾

DC Current Gain (I _C = 2 A, V _{CE} = 1V) (I _C = 4 A, V _{CE} = 1V)	h _{FE}	35 20	—	—
Collector-Emitter Saturation Voltage (I _C = 8A, I _B = 0.4A) (I _C = 8A, I _B = 0.4A, T _C = 100°C) (I _C = 15A, I _B = 3.0A, T _C = 100°C)	V _{CE(sat)}	— — —	0.4 0.5 0.8	V
Base-Emitter Saturation Voltage (I _C = 8A, I _B = 0.4A) (I _C = 8A, I _B = 0.4A, T _C = 100°C)	V _{BE(sat)}	— —	1.2 1.1	V

DYNAMIC CHARACTERISTICS

Typical

Current-Gain — Bandwidth Product (I _C = 0.1A, V _{CE} = 10V, f _{test} = 1 MHz)	f _T	50		MHz
Output Capacitance (V _{CB} = 10V, I _E = 0, f _{test} = 1 MHz)	C _{OB}	120		pF

SWITCHING CHARACTERISTICS

Maximum

Resistive Load (See Figure 16 for Test Circuit)		T _C	25°C	100°C	
Delay Time	V _{CC} = 20V, I _C = 8A I _{B1} = I _{B2} = 0.8A t _p = 25 μsec	t _d	50	—	nsec
Rise Time		t _r	250	—	nsec
Storage Time		t _s	700	—	nsec
Fall Time		t _f	200	—	nsec
Inductive Load, Clamped (See Figure 15 for Test Circuit)					
Storage Time	V _{CC} = 20V, I _C = 8A V _{CLAMP} = Rated V _{CEX} I _{B1} = 0.8A, V _{BE(off)} = -5V	t _s	800	—	nsec
Fall Time		t _f	180	400	nsec
			Typical		
Storage Time	L = 200 μh	t _s	280	370	nsec
Fall Time		t _f	130	150	nsec

(1) Pulse Duration = 300 μsec, Duty Factor ≤ 2%.

(2) See Figure 15 for Test Circuit.

D44VH Series

SAFE OPERATING AREA

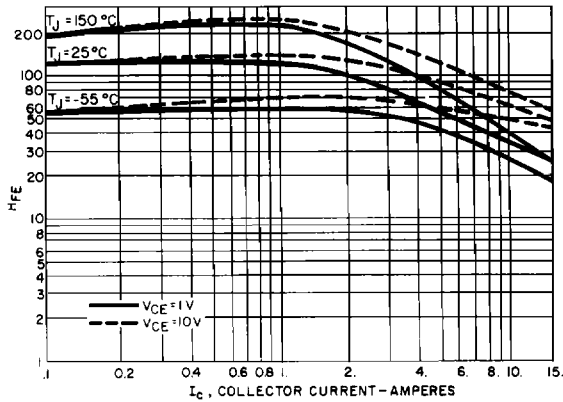

1. DC CURRENT GAIN

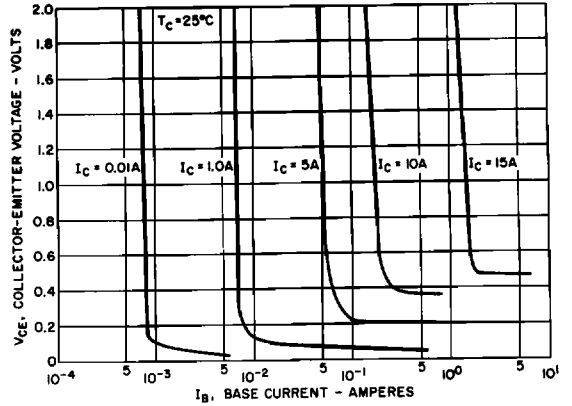

2. COLLECTOR SATURATION REGION

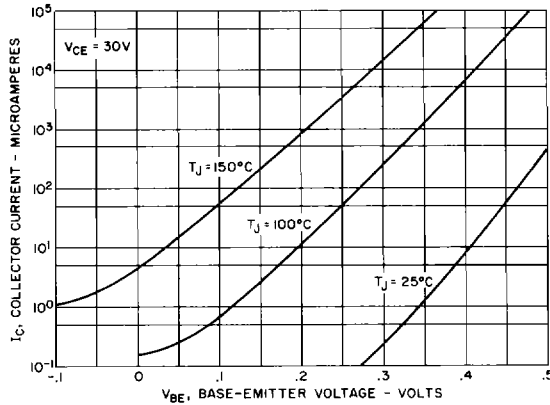

3. COLLECTOR CUTOFF REGION

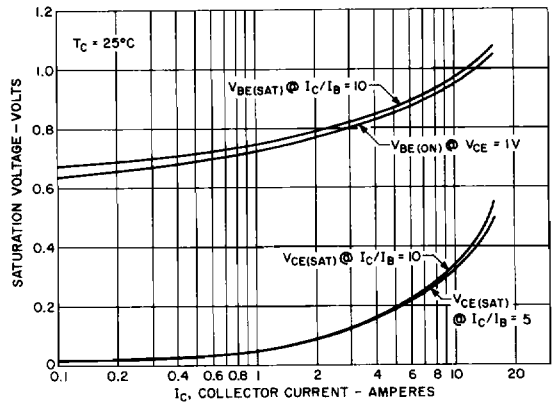

4. SATURATION VOLTAGE

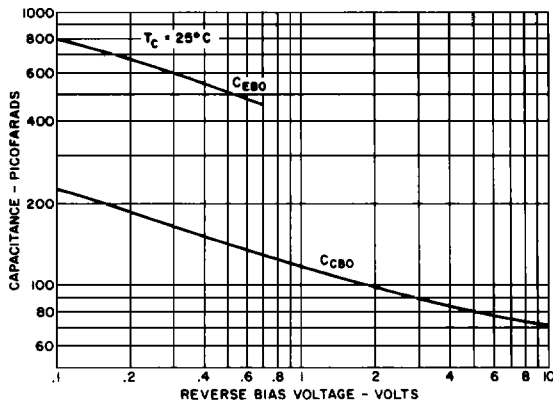

5. CAPACITANCE

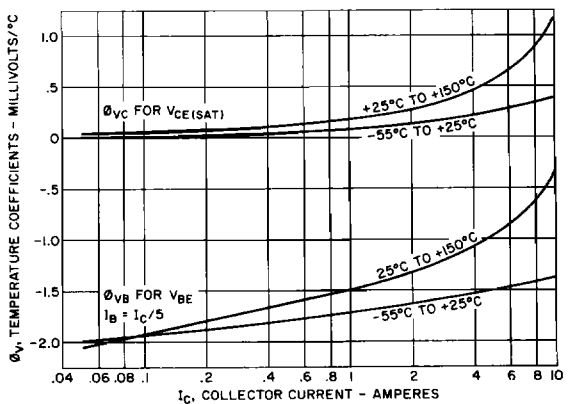

6. SATURATION VOLTAGE TEMPERATURE COEFFICIENTS

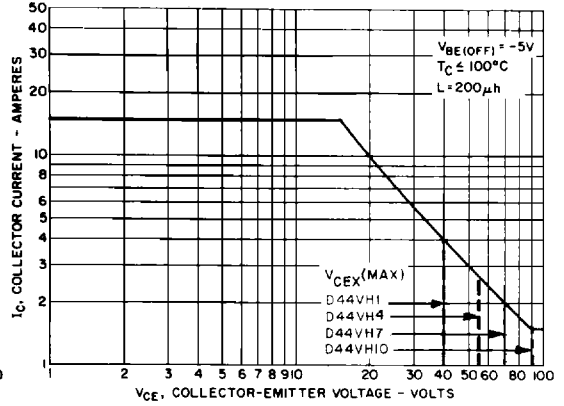
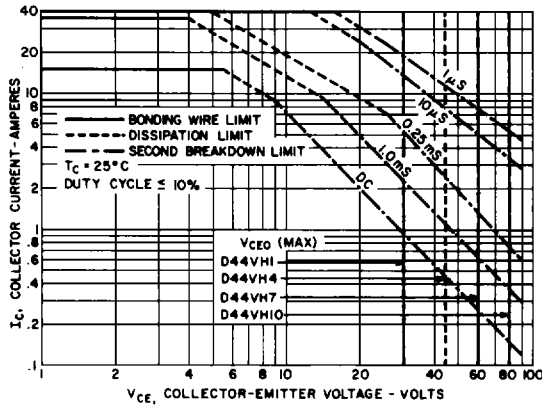

TYPICAL SWITCHING CHARACTERISTICS

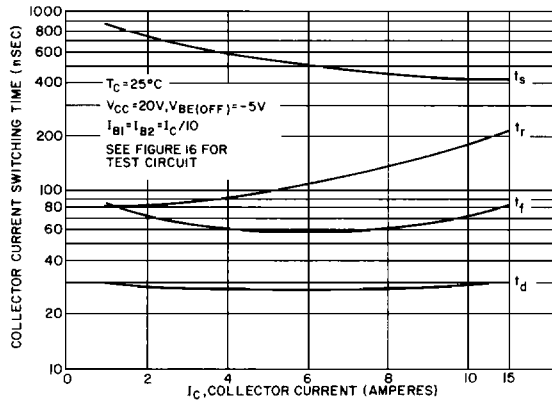

2
POWER TRANSISTORS

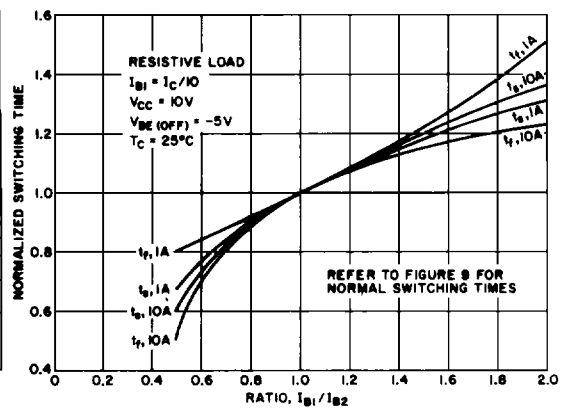
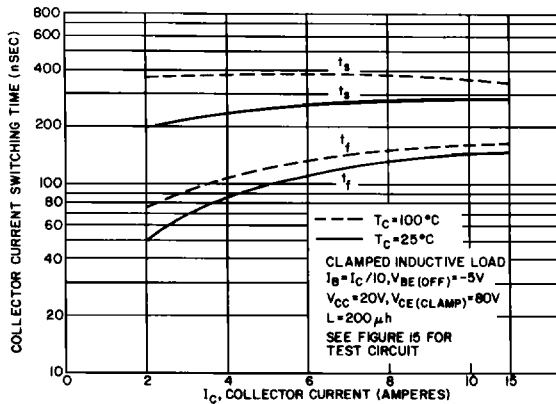

D44VH Series

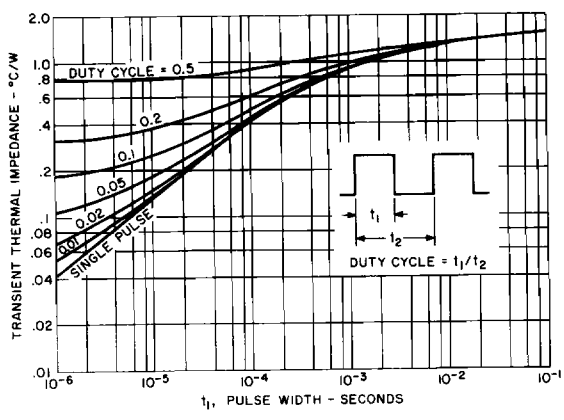

12. TRANSIENT THERMAL RESPONSE

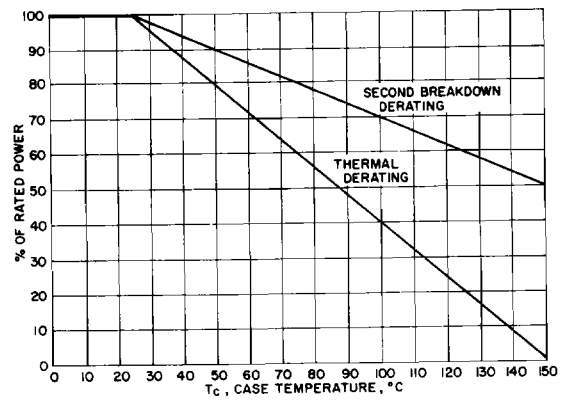

13. POWER DERATING FACTOR

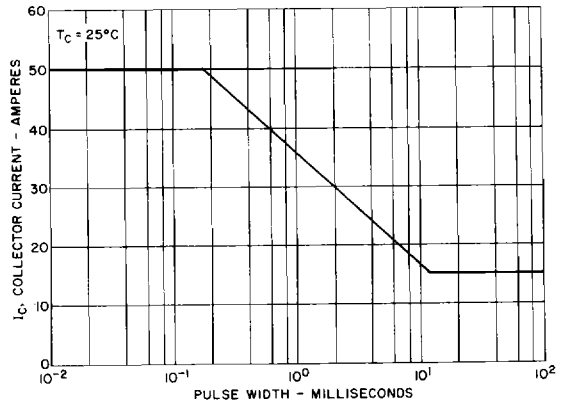

14. MAXIMUM SINGLE PULSE COLLECTOR CURRENT

TEST CIRCUITS

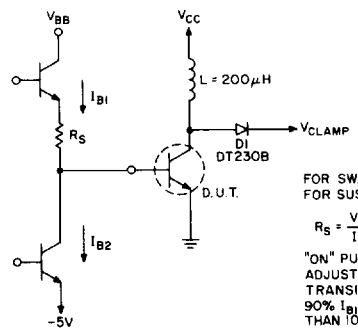

15. INDUCTIVE SWITCHING AND V_{CEX}

FOR SW. TIMES AND R_{BSOA} FOR SUSTAINING VOLTAGE
 $R_S = \frac{V_{BB}}{I_{B1}}$
 "ON" PULSE WIDTH AND V_{CC} ADJUSTED FOR DESIRED PEAK I_C .
 TRANSITION TIME FROM 90% I_{B1} TO 90% I_{B2} LESS THAN 10 nS.

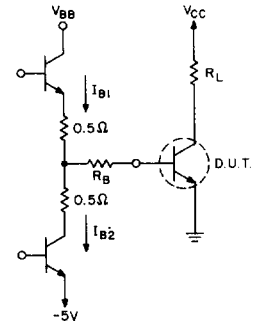

16. RESISTIVE SWITCHING

$R_L = \frac{V_{CC}}{I_C}$, NONINDUCTIVE
 $R_B = \frac{V_{BB}}{I_{B1}} - 0.5$
 TRANSITION TIME FROM 90% I_{B1} TO 90% I_{B2} LESS THAN 10 nS.