

**NPN SILICON EPITAXIAL TRANSISTOR**

**CIL9263  
TO237  
BCE**

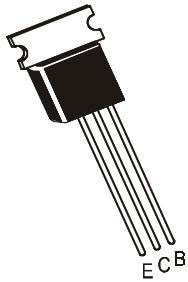

**High Voltage Transistor**

**ABSOLUTE MAXIMUM RATINGS**

DESCRIPTION	SYMBOL	VALUE	UNIT
Collector -Base Voltage	VCBO	250	V
Collector -Emitter Voltage	VCEO	250	V
Emitter Base Voltage	VEBO	6.0	V
Collector Current Continuous	IC	100	mA
Power Dissipation	PD	1.0	W
Operating & Storage Junction Temperature Range	TJ, Tstg	-65 to +150	deg C
Lead Temperature for Soldering 1/16" From Body, For 10 Seconds	TL	260	deg C
<b>THERMAL RESISTANCE</b>			
Junction to Case	Rth(j-c)	50	deg C/W
Junction to Ambient	Rth(j-a)	125	deg C/W

**ELECTRICAL CHARACTERISTICS (Ta=25 deg C)**

DESCRIPTION	SYMBOL	TEST CONDITION	MIN	MAX	UNIT
Collector -Base Voltage	VCBO	IC=100uA, IE=0	250	-	V
Collector -Emitter Voltage	VCEO	IC=7mA, IB=0	250	-	V
Emitter Base Voltage	VEBO	IE=100uA, IC=0	6.0	-	V
Collector Cut off Current	ICBO	VCB=250V, IE=0	-	1.0	uA
Emitter Cut off Current	IEBO	VEB=6V, IC=0	-	500	nA
DC Current Gain	hFE	IC=20mA, VCE=10V	75	-	
Collector Emitter Saturation Voltage	VCE(Sat)	IC=20mA, IB=2mA	-	2.5	V
Cut off frequency	ft	VCE=10V, IC=20mA	60	-	-
Feed Back Capacitance	Ccb	VCB=20V, IE=0, f=1MHz	-	3.0	pF

## TO-237 Plastic Package

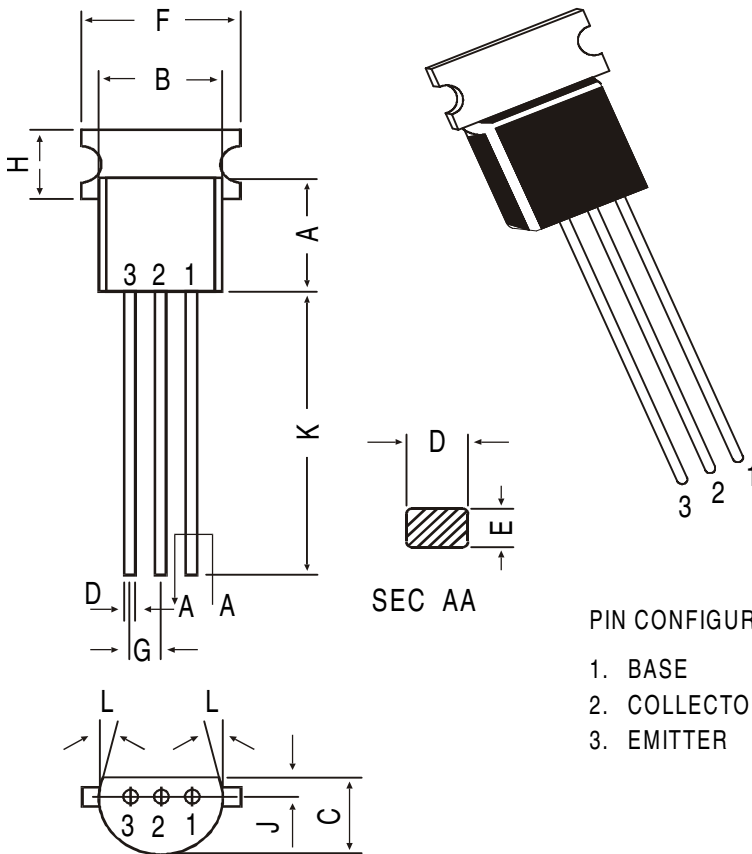

All dimensions in mm.

DIM	MIN.	MAX.
A	4.32	5.33
B	4.45	5.20
C	3.18	4.19
D	0.41	0.55
E	0.35	0.50
F	—	5.40
G	1.14	1.40
H	—	2.54
K	12.70	—
L	5 DEG	
J	1.14	1.53

### PIN CONFIGURATION

1. BASE
2. COLLECTOR
3. EMITTER

## Packing Detail

PACKAGE	STANDARD PACK		INNER CARTON BOX		OUTER CARTON BOX		
	Details	Net Weight/Qty	Size	Qty	Size	Qty	Gr Wt
TO-237 Bulk	1K/polybag	240 gm/1K pcs	3" x 7.5" x 7.5"	5.0K	17" x 15" x 13.5"	80.0K	26.2 kgs
TO-237 T&A	2K/ammo box	725 gm/2K pcs	12.5" x 8" x 1.8"	2.0K	17" x 15" x 13.5"	32.0K	13.8 kgs

## Disclaimer

The product information and the selection guides facilitate selection of the CDIL's Discrete Semiconductor Device(s) best suited for application in your product(s) as per your requirement. It is recommended that you completely review our Data Sheet(s) so as to confirm that the Device(s) meet functionality parameters for your application. The information furnished on the CDIL Web Site/CD is believed to be accurate and reliable. CDIL however, does not assume responsibility for inaccuracies or incomplete information. Furthermore, CDIL does not assume liability whatsoever, arising out of the application or use of any CDIL product; neither does it convey any license under its patent rights nor rights of others. These products are not designed for use in life saving/support appliances or systems. CDIL customers selling these products (either as individual Discrete Semiconductor Devices or incorporated in their end products), in any life saving/support appliances or systems or applications do so at their own risk and CDIL will not be responsible for any damages resulting from such sale(s).

CDIL strives for continuous improvement and reserves the right to change the specifications of its products without prior notice.



CDIL is a registered Trademark of

Continental Device India Limited

C-120 Naraina Industrial Area, New Delhi 110 028, India.

Telephone + 91-11-2579 6150, 5141 1112 Fax + 91-11-2579 5290, 5141 1119

email@cdil.com www.cdilsemi.com