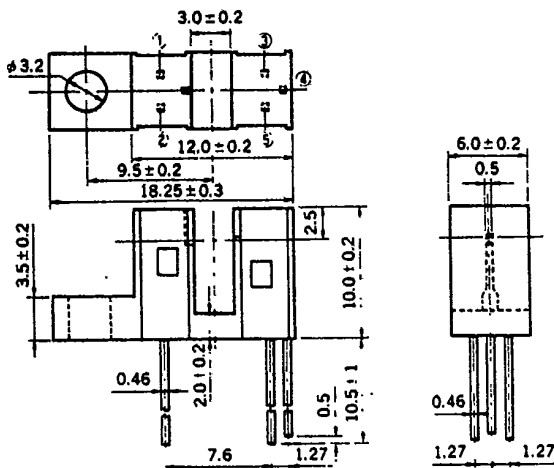

PHOTO INTERRUPTER PS5002HC

PHOTO IC INTERRUPTER

PACKAGE DIMENSIONS (Unit : mm)



CONNECTION DIAGRAM

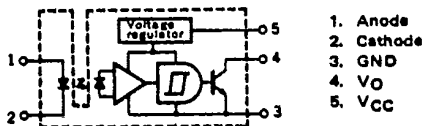

1. Anode
2. Cathode
3. GND
4. VO
5. VCC

APPLICATIONS

- PPC
- FACSIMILE
- PRINTER
- FDD

DESCRIPTION

The PS5002HC photo interrupter module is a GaAs Light Emitting Diode coupled to a Si monolithic integrated circuit including a Photo Diode in a plastic housing.

The output incorporates a Schmitt Trigger circuit which provides hysteresis for noise immunity and pulse shaping.

FEATURES

- Built-in Schmitt Trigger circuit
- Low threshold input current ($I_{FLH} = 5 \text{ mA MAX.}$)
- TTL, LSTTL, CMOS compatible
- Wide supply voltage capability ($V_{CC} = 4.5 \text{ to } 17 \text{ V}$)
- High On/Off resolution (Slit width: 0.5 mm (equivalent to 0.5 mm² aperture))
- High speed switching ($t_{PLH} (t_{PHL}) = 3 \mu\text{s TYP.}$
 $t_r = 100 \text{ ns, } t_f = 50 \text{ ns TYP.}$
@ $R_L = 280 \Omega$)
- Active "High"
- Open collector output

OUTPUT PATTERN

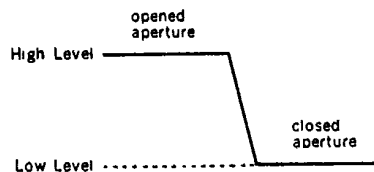

PS5002HC

ABSOLUTE MAXIMUM RATINGS ($T_a = 25^\circ\text{C}$)

Diode			
Reverse Voltage	V_R	6	V
Forward Current	I_F	50	mA
Power Dissipation	P_D	75	mW
Detector			
Supply Voltage	V_{CC}	17	V
Output Voltage	V_O	28	V
Low Level Output Current	I_{OL}	50	mA
Power Dissipation	P_C	250	mW
Storage Temperature	T_{stg}	-40 to +100	$^\circ\text{C}$
Operating Temperature	T_{opt}	-30 to +85	$^\circ\text{C}$

RECOMMENDED OPERATING CONDITIONS ($T_a = 25^\circ\text{C}$)

CHARACTERISTIC	SYMBOL	MIN.	TYP.	MAX.	UNIT
Operating Temperature	T_{opt}	-10		+60	$^\circ\text{C}$
Supply Voltage	V_{CC}	4.5	5	12	V
Forward Current	I_F	5		20	mA

ELECTRICAL CHARACTERISTICS ($T_a = 25^\circ\text{C}$)

	CHARACTERISTIC	SYMBOL	MIN.	TYP.	MAX.	UNIT	TEST CONDITIONS
Diode	Forward Voltage	V_F		1.1	1.4	V	$I_F = 5\text{ mA}$
	Reverse Current	I_R			10	μA	$V_R = 5\text{ V}$
	Junction Capacitance	C_t		20		pF	$V = 0, f = 1\text{ MHz}$
Detector	Operating Supply Voltage	V_{CC}	4.5		17	V	
	Low Level Output Voltage	V_{OL}		0.15	0.4	V	$I_{OL} = 16\text{ mA}, V_{CC} = 5\text{ V}$
	High Level Output Voltage	V_{OH}	4.9			V	$V_{CC} = 5\text{ V}, I_F = 5\text{ mA}$
	Low Level Supply Current	I_{CCL}		2.5	5	mA	$V_{CC} = 5\text{ V}, I_F = 0$
	High Level Supply Current	I_{CCH}		1	3	mA	$V_{CC} = 5\text{ V}, I_F = 5\text{ mA}$
Coupled	Threshold Input Current	I_{FLH}			5	mA	$V_{CC} = 5\text{ V}, R_L = 280\ \Omega$
	Hysteresis Ratio	I_{FHL}/I_{FLH}		0.7			$V_{CC} = 5\text{ V}, R_L = 280\ \Omega$
	Propagation Delay Time	t_{PLH}		3	9	μs	$V_{CC} = 5\text{ V}$
		t_{PHL}		3	9	μs	
	Rise Time	t_r		100	300	ns	$I_F = 5\text{ mA}$
	Fall Time	t_f		50	150	ns	$R_L = 280\ \Omega$

Test Circuit for Switching Time

