

RoHS Compliant Product
A suffix of "-C" specifies halogen and lead-free

DESCRIPTION

The KS05E4 is designed to protect I/Os being sensitive concerning capacitive load, such as USB2.0, Ethernet, DVI etc. from destruction by ElectroStatic Discharges (ESD).

Therefore, the KS05E4 incorporates four pairs of ultra-low capacity rail-to-rail diodes plus an additional Zener diode to provide protection to downstream signal and supply components from Electrostatic Discharge (ESD) voltages as high as
Due to the rail-to-rail diodes being connected to the Zener diode, the protection is working independent from the availability of a supply voltage.

The KS05E4 is fabricated using thin film-on-silicon technology and integrates 4 ultra-low capacity rail-to-rail ESD protection diodes in a miniature SOT-26 package

SOT-26

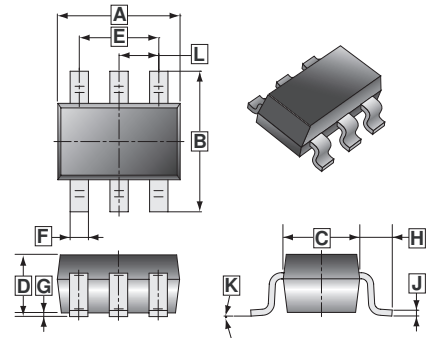

REF.	Millimeter		REF.	Millimeter	
	Min.	Max.		Min.	Max.
A	2.70	3.10	G	0	0.10
B	2.60	3.00	H	0.60	REF.
C	1.40	1.80	J	0.12	REF.
D	1.30	MAX.	K	0°	10°
E	1.90	REF.	L	0.95	REF.
F	0.30	0.50			

APPLICATIONS

- Digital Cameras
- Portable Instrumentation
- Notebooks, Desktops, and Servers
- Personal Digital Assistants (PDAs)
- Cell phone handsets and accessories

FEATURES

- low clamping voltage
- Low leakage current
- Small package
- SOT-26 package
- ESD IEC 6100-4-2 Level 4, ±8 kV Contact Discharge Compliant Protection

MARKING

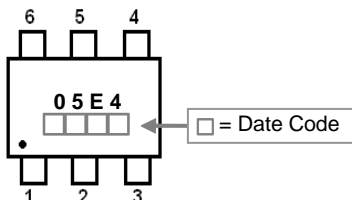

Top View

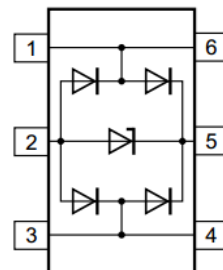

PACKAGE INFORMATION

Package	MPQ	Leader Size
SOT-26	3K	7 inch

ABSOLUTE MAXIMUM RATINGS ($T_A=25^{\circ}\text{C}$ unless otherwise specified)

Rating		Symbol	Value	Unit
IEC 61000-4-2 (ESD)	Air	V_{ESD}	± 14	kV
	Contact		± 8	
Peak pulse current ($t_p=8/20\mu\text{s}$)	$V_{\text{DD}}\text{-GND}$	I_{PP}	6	A
Peak pulse power ($t_p=8/20\mu\text{s}$)		P_{PK}	100	W
Operating Temperature Range		T_{J}	-40~85	$^{\circ}\text{C}$
Storage temperature range		T_{STG}	-55 ~ 125	$^{\circ}\text{C}$
Lead temperature		T_{L}	260	$^{\circ}\text{C}$

ELECTRICAL CHARACTERISTICS ($T_A=25^{\circ}\text{C}$ unless otherwise specified)

Parameter	Symbol	Condition	Min.	Typ.	Max.	Units
DC Input Voltage Range	V_{IO}		-	-	5.5	V
Zener Diode Breakdown Voltage, Pin 5 to 2	$V_{\text{BR}/\text{IO}}$	$I=1\text{mA}$	6	-	9	V
Forward Voltage	V_{F}		-	0.7	-	V
Diode Reverse Leakage Current, Pins 1,3,4,6 to Ground	I_{lkG}	$V_{\text{RWM}}=3\text{V}$	-	-	100	nA
Pin Capacitance to Ground, Pins 1,3,4,6	$C_{\text{I/O}}$	$V_{\text{dc}}=0\text{V}$, $f=1\text{MHz}$ Pin 5=3V	-	1.8	-	pF
Zener Diode Capacitance to Ground, Pin 5 to 2	C_{ZENER}	$V_{\text{dc}}=0\text{V}$, $f=1\text{MHz}$ Pin 5=3V	-	36	-	pF
Clamping Voltage, $V_{\text{DD}}\text{-GND}$	V_{C}	$I_{\text{PP}}=1\text{A}$, $t_p=8/20\mu\text{s}$	-	-	8	V
		$I_{\text{PP}}=4\text{A}$, $t_p=8/20\mu\text{s}$	-	-	8.5	V
		$I_{\text{PP}}=9\text{A}$, $t_p=8/20\mu\text{s}$	-	-	12	V

Applications Information

Universal Serial Bus 2.0 Protection

The KS05E4 is optimized to protect e.g. two USB 2.0 ports of Electro-Static-Discharge (ESD). Each device is capable of protection both USB data lines and the VBUS supply. A typical application is shown in the schematic below.

