



**CMSZDA3V6
THRU
CMSZDA33V**

**DUAL ZENER DIODE
3.6 VOLTS THRU 33 VOLTS
250mW, 5% TOLERANCE**

**SUPER™
mini**



SOT-323 CASE

**Central™
Semiconductor Corp.**

DESCRIPTION:

The CENTRAL SEMICONDUCTOR CMSZDA3V6 Series Silicon Dual Zener Diode is a high quality voltage regulator, connected in a common anode configuration, for use in industrial, commercial, entertainment and computer applications.

ABSOLUTE MAXIMUM RATINGS
Power Dissipation (@ $T_A=25^{\circ}C$)
Operating and Storage Temperature
Thermal Resistance

SYMBOL
 P_D
 T_J, T_{stg}
 θ_{JA}

250
-65 to +150
500

UNIT
mW
 $^{\circ}C$
 $^{\circ}C/W$

ELECTRICAL CHARACTERISTICS ($T_A=25^{\circ}C$), $V_F=0.9V$ MAX @ $I_F=10mA$ FOR ALL TYPES.

TYPE NO.	ZENER VOLTAGE $V_Z @ I_{ZT}$		TEST CURRENT I_{ZT}	MAXIMUM ZENER IMPEDANCE			MAXIMUM REVERSE CURRENT		MAXIMUM ZENER CURRENT I_{ZM}	MAXIMUM ZENER VOLTAGE TEMPERATURE COEFFICIENT θ_{VZ}	MARKING CODE
	MIN	MAX		$Z_{ZT} @ I_{ZT}$	$Z_{ZK} @ I_{ZK}$	$I_R @ V_R$					
	VOLTS	VOLTS	mA	Ω	Ω	mA	μA	VOLTS	mA	%/°C	
CMPZDA3V6	3.4	3.8	5.0	95	600	1.0	2.0	1.0	45	-0.06	W7W
CMPZDA3V9	3.7	4.1	5.0	90	600	1.0	2.0	1.0	43	-0.06	W8W
CMPZDA4V3	4.0	4.6	5.0	90	600	1.0	1.0	1.0	40	-0.05	W9W
CMPZDA4V7	4.4	5.0	5.0	80	500	1.0	3.0	2.0	38	-0.03	Z1Z
CMPZDA5V1	4.8	5.4	5.0	60	480	1.0	2.0	2.0	35	0.02	Z2Z
CMPZDA5V6	5.2	6.0	5.0	40	400	1.0	1.0	2.0	32	0.03	Z3Z
CMPZDA6V2	5.8	6.6	5.0	10	150	1.0	3.0	4.0	28	0.04	Z4Z
CMPZDA6V8	6.4	7.2	5.0	15	80	1.0	2.0	4.0	25	0.05	Z5Z
CMPZDA7V5	7.0	7.9	5.0	15	80	1.0	1.0	5.0	23	0.05	Z6Z
CMPZDA8V2	7.7	8.7	5.0	15	80	1.0	0.7	5.0	21	0.06	Z7Z
CMPZDA9V1	8.5	9.6	5.0	15	100	1.0	0.5	6.0	18	0.06	Z8Z
CMPZDA10V	9.4	10.6	5.0	20	150	1.0	0.2	7.0	16	0.07	Z9Z
CMPZDA11V	10.4	11.6	5.0	20	150	1.0	0.1	8.0	15	0.07	Y1Y
CMPZDA12V	11.4	12.7	5.0	25	150	1.0	0.1	8.0	13	0.07	Y2Y
CMPZDA13V	12.4	14.1	5.0	30	170	1.0	0.1	8.0	12	0.08	Y3Y
CMPZDA15V	13.8	15.6	5.0	30	200	1.0	0.05	10.5	11	0.08	Y4Y
CMPZDA16V	15.3	17.1	5.0	40	200	1.0	0.05	11.2	10	0.08	Y5Y
CMPZDA18V	16.8	19.1	5.0	45	225	1.0	0.05	12.6	9.2	0.08	Y6Y
CMPZDA20V	18.8	21.2	5.0	55	225	1.0	0.05	14.0	8.3	0.08	Y7Y
CMPZDA22V	20.8	23.3	5.0	55	250	1.0	0.05	15.4	7.6	0.09	Y8Y
CMPZDA24V	22.8	25.6	5.0	70	250	1.0	0.05	16.8	7.0	0.09	Y9Y
CMPZDA27V	25.1	28.9	2.0	80	300	0.5	0.05	18.9	6.2	0.09	10W
CMPZDA30V	28.0	32.0	2.0	80	300	0.5	0.05	21.0	5.6	0.09	11W
CMPZDA33V	31.0	35.0	2.0	80	325	0.5	0.05	23.1	5.0	0.09	12W

All dimensions in inches (mm).

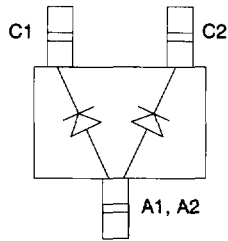
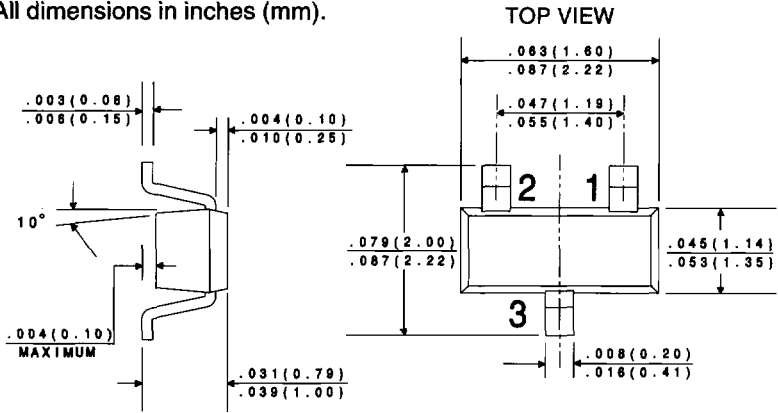

DATA SHEET