

Phase-out/Discontinued

2SK876

DESCRIPTION The 2SK876 is N-channel MOS Field Effect Power Transistor designed for switching power supplies, DC-DC converters.

- FEATURES**
- Suitable for switching power supplies, actuator controls, and pulse circuits.
 - Low $R_{DS(on)}$
 - No second breakdown

ABSOLUTE MAXIMUM RATINGS

Maximum Temperatures

Storage Temperature -55 to $+150$ °C

Channel Temperature 150 °C Maximum

Maximum Power Dissipation ($T_C = 25$ °C)

Total Power Dissipation **120** W

Maximum Voltages and Currents ($T_a = 25$ °C)

V_{DSS} Drain to Source Voltage **500** V

V_{GSS} Gate to Source Voltage ± 20 V

$I_{D(DC)}$ Drain Current (DC) ± 12 A

$I_{D(pulse)}$ Drain Current(pulse)* ± 48 A

* $PW \leq 100 \mu s$, Duty Cycle $\leq 2\%$

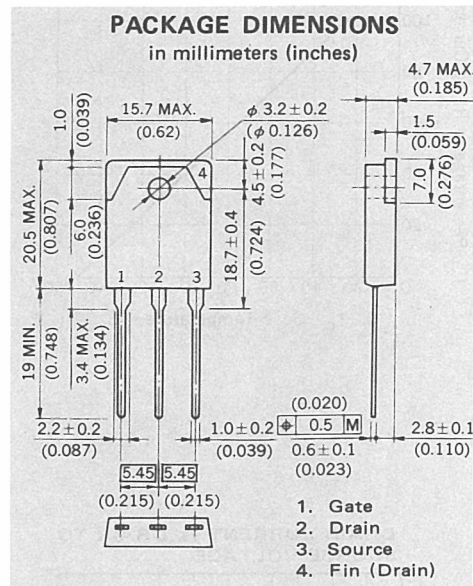

ELECTRICAL CHARACTERISTICS ($T_a = 25$ °C)

SYMBOL	CHARACTERISTIC	MIN.	TYP.	MAX.	UNIT	TEST CONDITIONS
I_{DSS}	Drain Leakage Current			100	μA	$V_{DS} = 500 V, V_{GS} = 0$
I_{GSS}	Gate to Source Leakage Current			± 100	nA	$V_{GS} = \pm 20 V, V_{DS} = 0$
$V_{GS(off)}$	Gate to Source Cutoff Voltage	1.5		3.5	V	$V_{DS} = 10 V, I_D = 1 mA$
$ Y_{fs} $	Forward Transfer Admittance	5.0			S	$V_{DS} = 10 V, I_D = 6 A$
$R_{DS(on)}$	Drain to Source On-State Resistance		0.6	0.7	Ω	$V_{GS} = 10 V, I_D = 6 A$
C_{iss}	Input Capacitance		2000		pF	$V_{DS} = 10 V, V_{GS} = 0, f = 1 MHz$
C_{oss}	Output Capacitance		450		pF	
C_{rss}	Reverse Transfer Capacitance		120		pF	
$t_{d(on)}$	Turn-On Delay Time		30		ns	$I_D = 6 A, V_{DD} \cong 150 V$ $V_{GS(on)} = 10 V$ $R_L = 25 \Omega$ $R_{in} = 10 \Omega$
t_r	Rise Time		50		ns	
$t_{d(off)}$	Turn-Off Delay Time		100		ns	
t_f	Fall Time		50		ns	

TYPICAL CHARACTERISTICS ($T_a = 25^\circ\text{C}$)

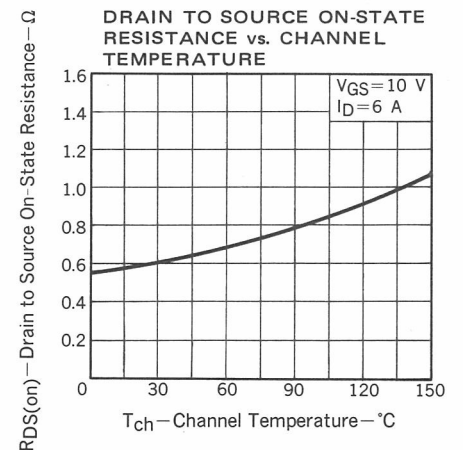
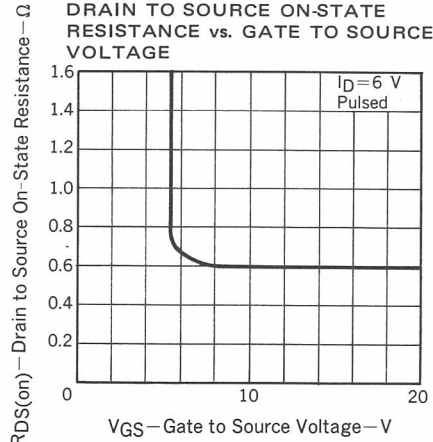
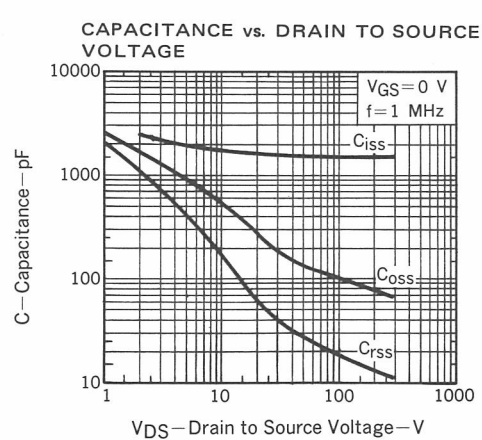
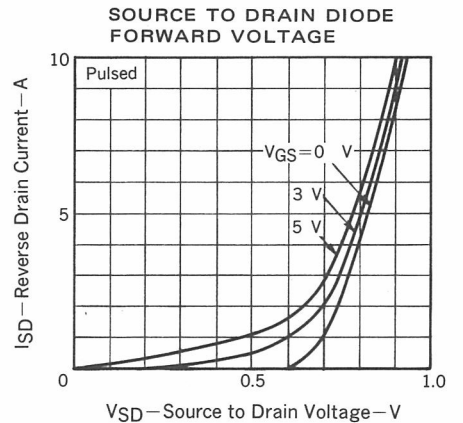
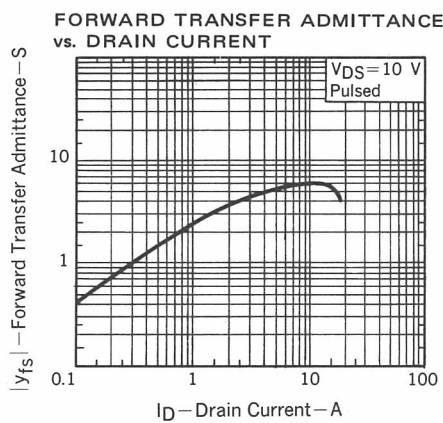
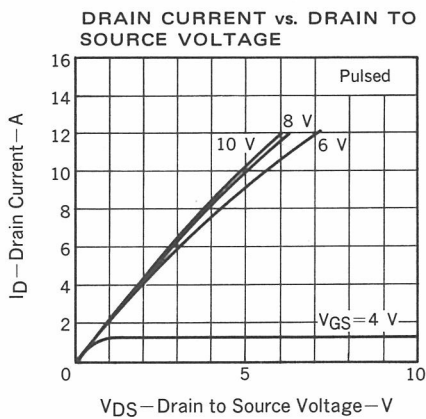
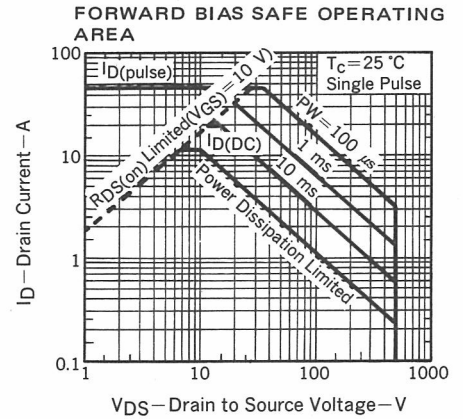
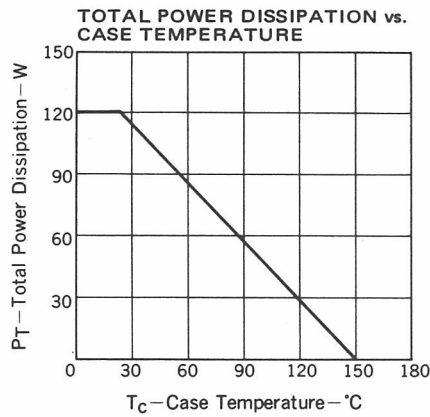
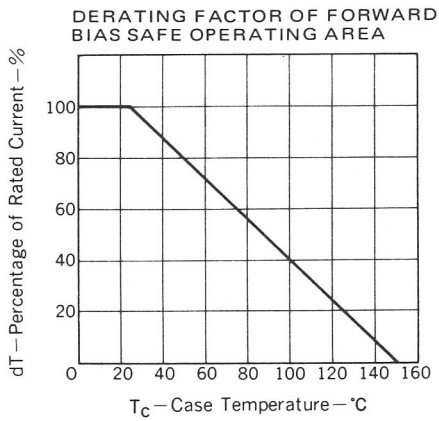

Phase-out/Discontinued

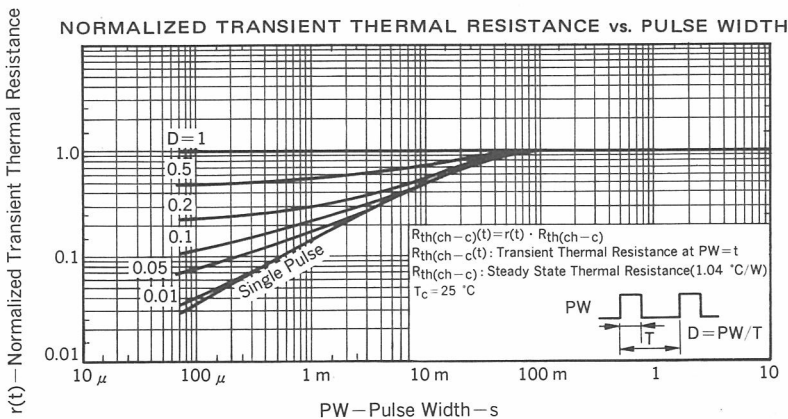
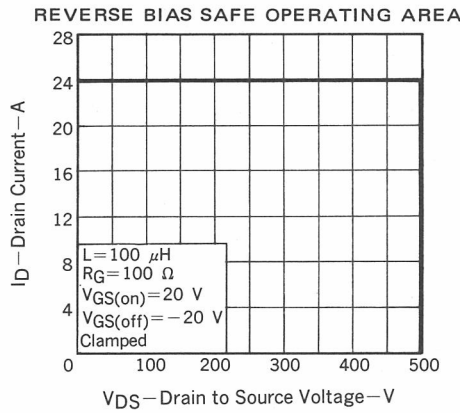
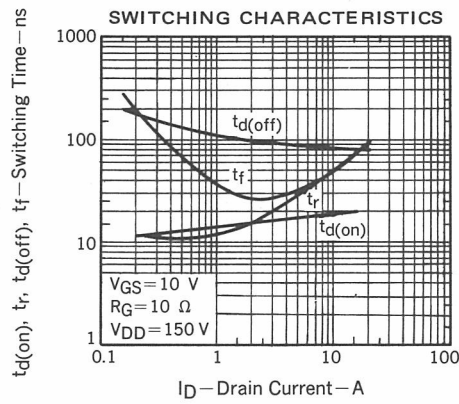
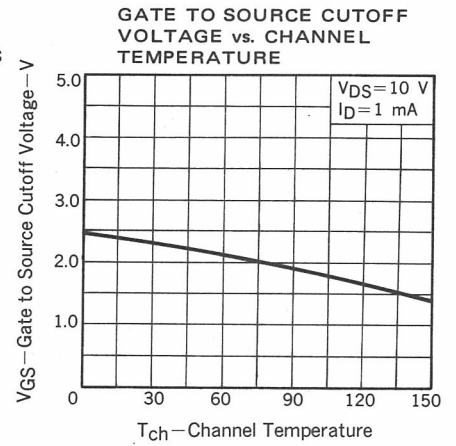
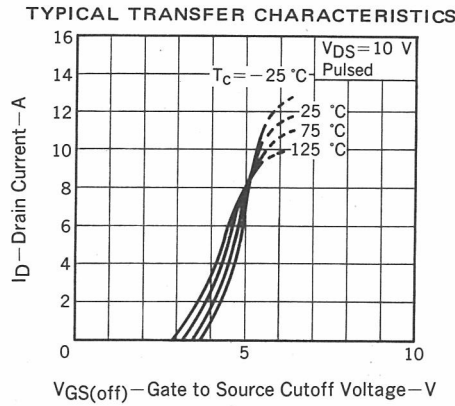
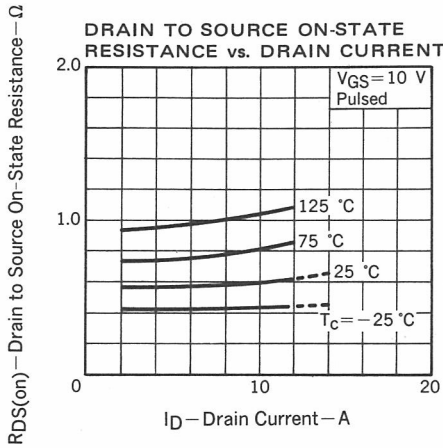

Phase-out/Discontinued

SWITCHING TIME TEST CIRCUIT

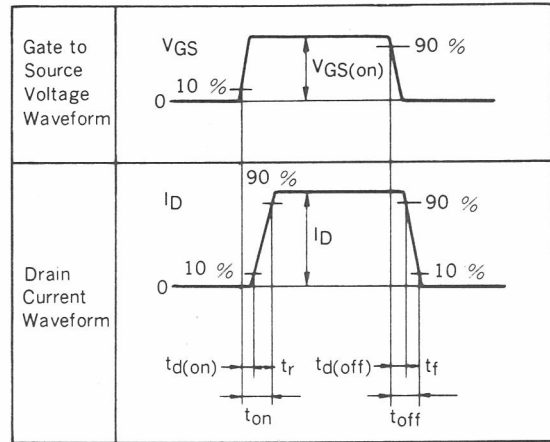
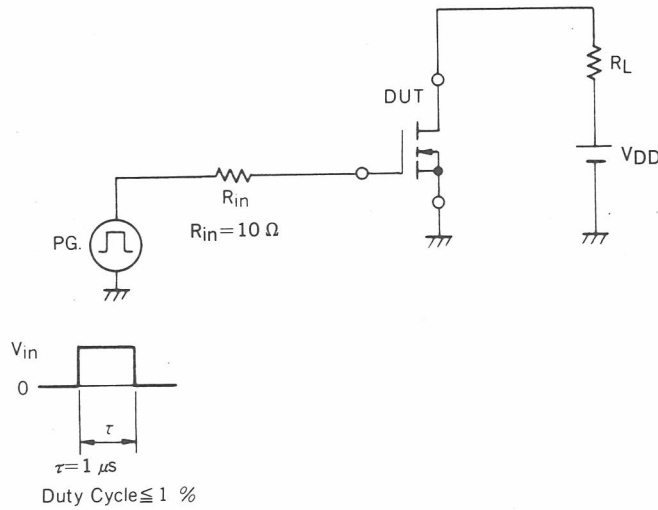

CLAMPED INDUCTIVE TEST CIRCUIT

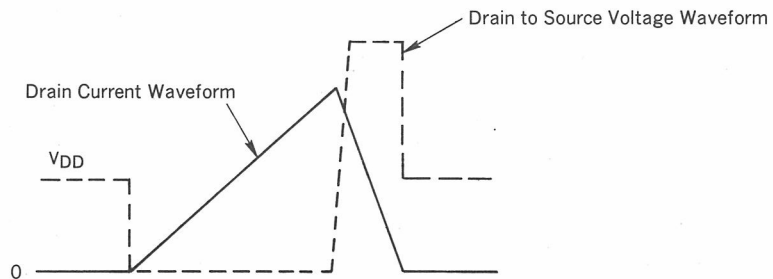
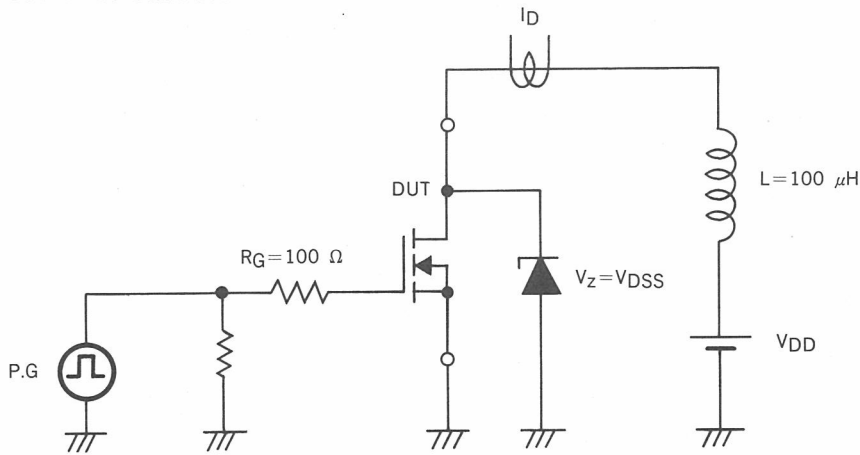

Clamped Inductive Waveforms