

Description

The GM19371 is a step up DC/DC convert specifically designed to drive white LED;s with a constant current. The device can drive up to 27 LEDs from a 5V supply.

Additional feature includes output voltage limiting when LEDs are disconnected.

GM19371 is available in SOT-26 package.

Features

- ◆ Inherently matched LED current
- ◆ Drives up to 126LEDs (9S14P) from a 12V supply
- ◆ 36V rugged bipolar switch
- ◆ Fast 1.2MHz switching frequency
- ◆ Over Voltage Protection, 30V

Application

Cellular phones

PDAs, Handheld Computers

Digital Cameras

MP3 Player

GPS Receivers

MR16 Lighting

Typical Application Circuits

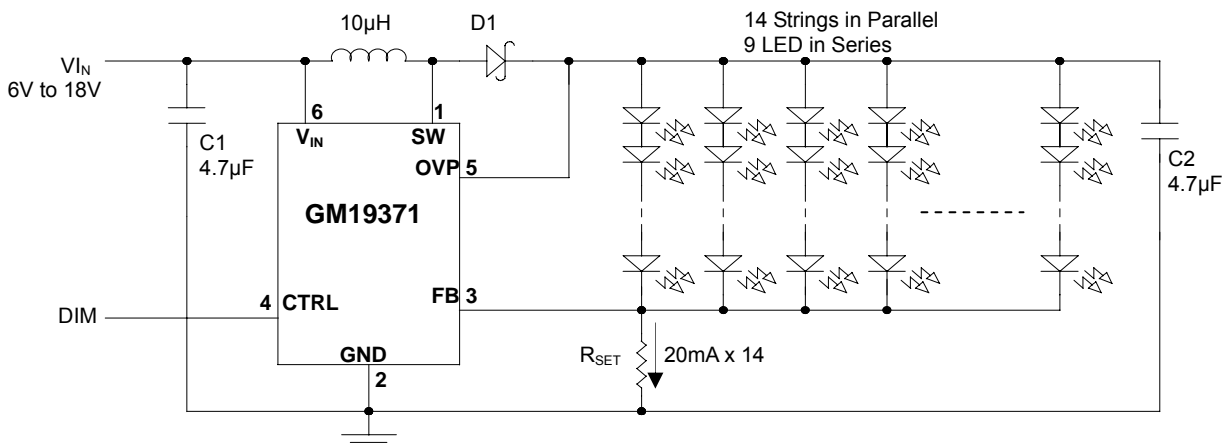
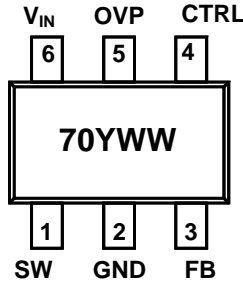

Figure 1 GM19371 typical application

Marking Information and Pin Configurations (Top View)

SOT26



70: Device Code, Green Product

Y: Year

WW: Week code

Pin Descriptions

Pin Number	Pin Name	Pin Function
1	SW	This is the collector of the internal NPN power switch. Connect to inductor and diode. Minimize the metal trace area connected to this pin to reduce EMI.
2	GND	Ground
3	FB	Reference voltage is 95mV. Connect LEDs and a resistor at this pin. LED current is determined by the resistance and CTRL voltage. R_{SET} resistor value is calculated as $R_{SET} = 95mV/I_{LED}$
4	CTRL	This Pin could be used as either shut down or dimming functions: When $V_{CTRL} > 1.8V$, generates full scale LED current $V_{CTRL} < 0.4V$, chip is OFF $0.4V \leq V_{CTRL} \leq 1.8V$, PWM duty cycle controls the LED current
5	OVP	Over Voltage Protection, 30V
6	V_{IN}	The input supply pin, bypass this pin with a capacitor as close to the device as possible

Ordering Information – Green Products

Ordering Number	Package	Shipping
GM19371-ST26RG	SOT-26	3,000 Units/Tape and Reel

Absolute Maximum Ratings (Note 1)

PARAMETER	SYMBOL	RATINGS	UNITS
Input Voltage	V_{IN}	20	V
SW Voltage	V_{SW}	36	V
FB Voltage	V_{FB}	10	V
/SHDN Voltage	V_{CTRL}	10	V
Junction Temperature	T_J	-40 to 125	°C
Storage Temperature	T_{stg}	- 65 to 150	°C
Lead Temperature (soldering, 5 sec)		260	°C

Note 1: Stresses greater than those listed under Maximum Ratings may cause permanent damage to the device.

Recommended Operating Conditions

Rating	Symbol	Value	Unit
Maximum Supply Voltage	V_{IN}	2.5 to 18	V
Output Voltage	V_{OUT}	28	V
Operating Temperature Range	T_{OPR}	0 to 70	°C

Electrical Characteristics ($V_{IN} = 5V$, $V_{SHDN} = 5V$, $T_A = 25^\circ C$, unless otherwise noted)

Parameter	Symbol	Condition	Min	Typ	Max	Unit
Operating Voltage Range	V_{IN}		2.5		18	V
Feedback Voltage	V_{FB}	$I_{LOAD} = 180mA$	80	95	107	mV
FB Pin Bias Current	I_{FB}	$V_{IN} = V_{OUT} + 1V$ to 16V	10	45	100	nA
Supply Current	I_{CC}			2.1	3.0	mA
Standby Current	I_{STBY}	$V_{SHDN} = 0V$		0.1	1.0	μA
Switching Frequency	f_{OSC}		1.1	1.3	1.6	MHz
Maximum Duty Cycle	D_{MAX}		85	90		%
Switch Current Limit	I_{CL}			650		mA
Switch V_{CESAT}	V_{SAT}	$I_{SW} = 250mA$		350		mV
Switch Leakage Current	I_{LEAK}	$V_{SW} = 5V$		0.01	5	μA
CTRL Voltage High	V_{TH}		1.5			V
CTRL Voltage Low	V_{TL}				0.4	V
CTRL Pin Bias Current	I_{CTRL}			65		μA
OVP Threshold				29		V

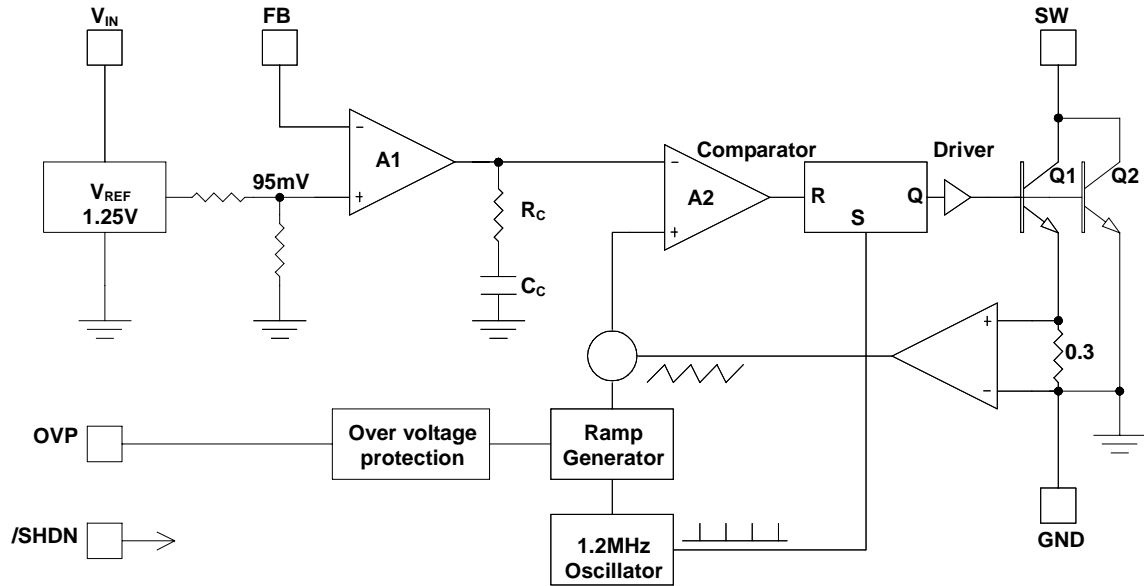

Figure 2 GM19371 Block Diagram

Typical; Application Circuits

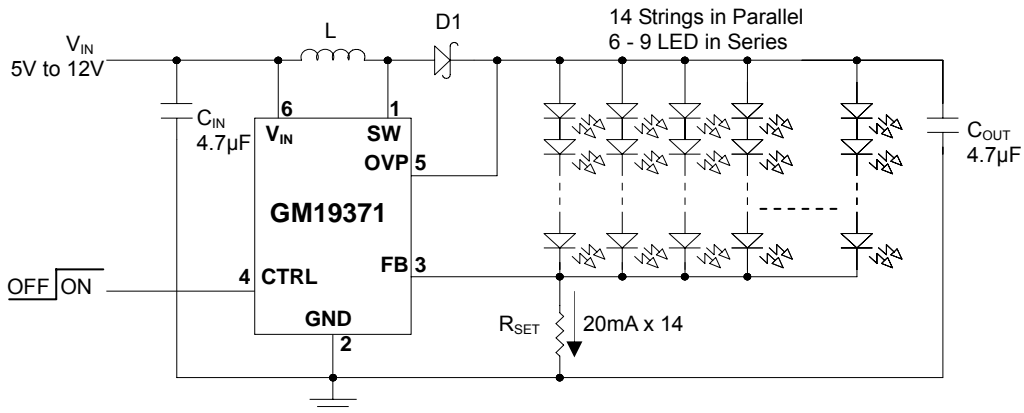

Figure 3 GM19371, typical application

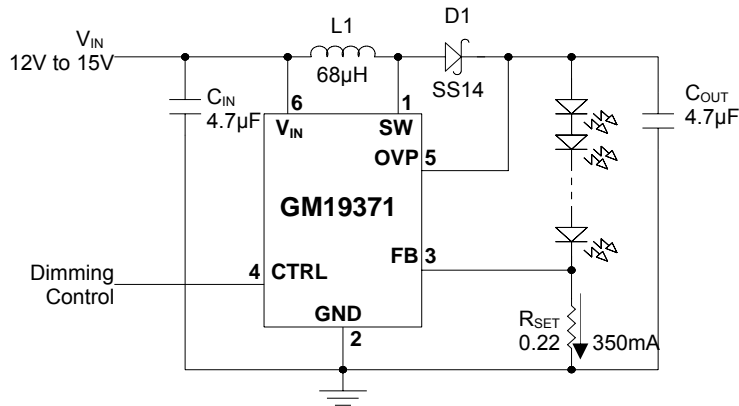

Figure 4. GM19371 – application for 1W LED x 6

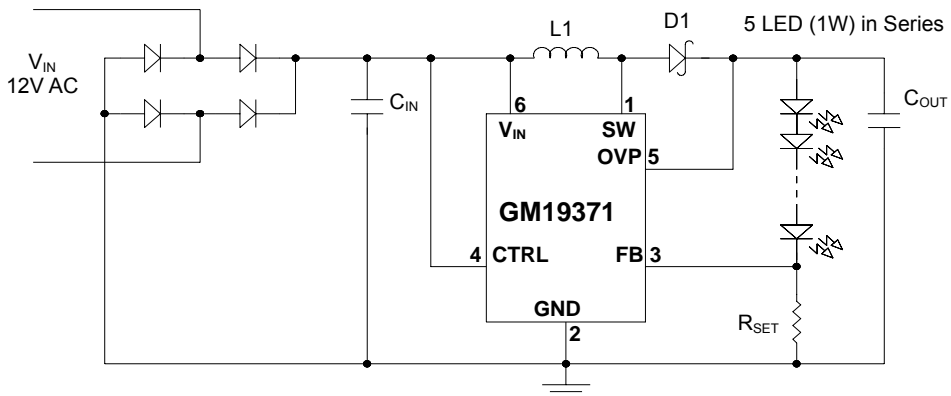

Figure 5. GM19371 – application for 1MR16 with 1W LED in series

Application Information

General Operation

The GM19371 uses a constant frequency, current mode control scheme to provide excellent line and load regulations. See Fig 2 for GM19371 operation. At the start of each oscillator cycle, the RS latch is set, which turns on the power switch Q1. A voltage proportional to the switch current is added to a stabilizing ramp and the resulting sum is fed into the positive terminal of the PWM comparator A2. When this voltage exceeds the level at the negative input of A2, the RS latch is reset turning off the power switch. The level at the negative input of A2 is set by the error amplifier A1, and is simply an amplified version of the difference between the feedback voltage and the reference voltage of 95mV. In this manner, the error amplifier sets the correct peak current level to keep the output in regulation. If the error amplifier's output increases, more current is delivered to the output; if it decreases, less current is delivered.

Over Voltage Protection and Open Circuit Protection

In case of output open circuit, while the LED strings are disconnected from the circuit or the LEDs fail open, the feedback voltage, VFB, will be zero. The GM19371 will then switch at a high duty cycle resulting in a high output voltage, which may cause the SW pin voltage to exceed its maximum voltage rating. In order to prevent this condition occur, the GM19317 builds a latch-mode open-circuit protection circuit. Based on the result from the sensing pin, OVP pin, the chip can detect the output open condition when the OVP voltage is higher than 30V. The chip will shutdown until V_{IN} reset

Inductor Selection

A 10uH inductor is recommended for most GM19371 applications. Although small size and high efficiency are major concerns, the inductor should have low core losses at 1.2MHz and low DCR (copper wire resistance).

Capacitor Selection

The small size of ceramic capacitors makes them ideal for GM19371 applications. X5R and X7R types are recommended because they retain their capacitance over wider voltage and temperature ranges than other types such as Y5V or Z5U. A 4.7uF input capacitor and a 4.7uF output capacitor are sufficient for most GM19371 applications.

Diode Selection

Schottky diodes, with their low forward voltage drop and fast reverse recovery, are the ideal choices for GM19371 applications. The forward voltage drop of a Schottky diode represents the conduction losses in the diode while the diode capacitance (CT or CD) represents the switching losses. For diode selection, both forward voltage drop and diode capacitance need to be considered. Schottky diodes with higher current ratings usually have lower forward voltage drop and larger diode capacitance, which can cause significant switching losses at the 1.2MHz switching frequency of the GM19371. A Schottky diode rated at 1000mA is sufficient for most GM19371 applications.

Soft Start and Current Limit

The internal soft start circuit minimizes the inrush current during turning on GM19371. The Typical switch current is limited to about 650mA by the chip.

LED Current Control

The LED current is controlled by the feedback resistor (R1, in Fig 1). The feedback reference is 95mV. The LED current is $95\text{mV}/R1$. The formula and table 1 for R1 selection are shown below. $R1=95\text{mV}/I_{\text{LED}}$

Table 1 R_{SET} resistor value selection

I_{LED}	R1 (Ω)
5	19.1
10	9.53
15	6.34
20	4.75
60	1.56
350	0.22

Dimming Control

1. Using a PWM Signal to CTRL Pin

With the PWM signal applied to the CTRL pin, the GM19371 is turned on or off by the PWM signal. The LED operate at either zero or full current. The average LED current increases proportionally with the duty cycle of the PWM signal. A 0% duty cycle will turn off the GM19371 and corresponds to zero LED current. A 100% duty cycle corresponds to full current. The typical frequency range of the PWM signal is 100Hz to 1KHz. The magnitude of the PWM signal should be higher than the minimum CTRL voltage high.

2. Using a DC Voltage

For some applications, the preferred method of brightness control is a variable DC voltage to adjust the LED current. The dimming control using a DC voltage is shown in below figure 6. As the DC voltage increases, the voltage drop on R1 increases and the voltage drop on RSET decreases. Thus, the LED current decreases. The selection of R1 and R2 should make the current from the variable DC source much smaller than the LED current and much larger than the FB pin bias current. For VDC range from 0V to 2V, the selection of resistors in below figure gives dimming control of LED current from 0mA to 15mA.

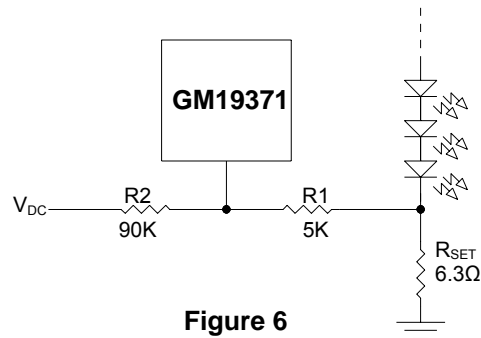

Figure 6

3. Using a DC Voltage

For The filtered PWM signal can be considered as an adjustable DC voltage. It can be used to replace the variable DC voltage source in dimming control. The circuit is show in figure 7

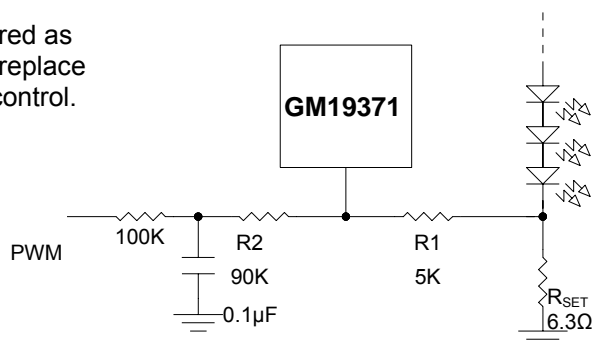

Figure 7

4. Using a Logic Signal

For applications that need to adjust the LED current in discrete steps, a logic signal can be used as shown in figure 8. R_{SET} sets the minimum LED current (when the NMOS is off). R_{INC} sets how much the LED current increases when the NMOS is turned on. The selection of R_{SET} and R_{INC} follows the formula and Table in “LED Current Control” section.

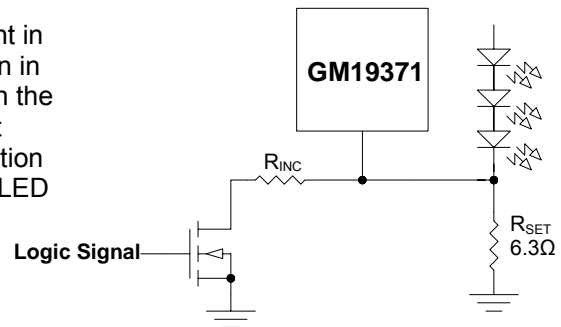
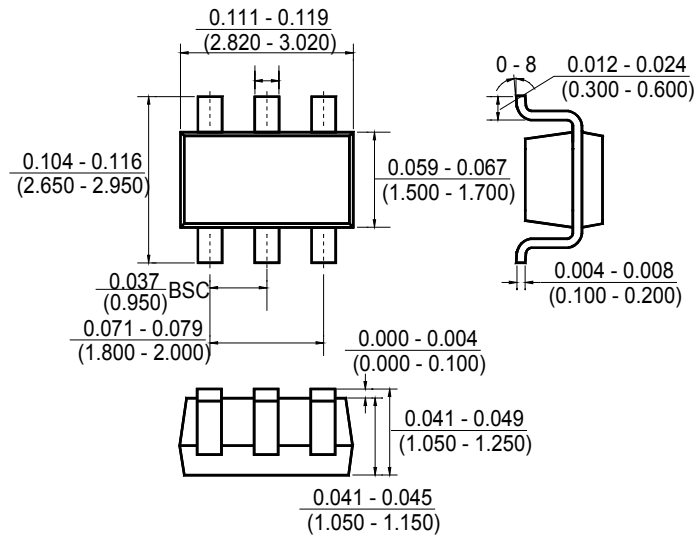

Figure 8

Board Layout Consideration

As with all switching regulators, careful attention must be paid to the PCB board layout and component placement. To maximize efficiency, the rising and falling times of the switch are made as short as possible. To prevent electromagnetic interference (EMI) problems, proper layout of the high frequency switching path is essential. The voltage signal of the SW pin has sharp rising and falling edges. Minimize the length and area of all traces connected to the SW pin and always use a ground plane under the switching regulator to minimize inter-plane coupling. In addition, the ground connection for the feedback resistor R_{SET} should be tied directly to the GND pin and not shared with any other component, ensuring a clean, noise-free connection.

Package Outline Dimensions – SOT 26



Ordering Number

GM 19371 ST26 R G

APM Gamma Micro	Circuit Type	Package Type	Shipping Type
		ST26: SOT 26	R: Tape & Reel Blank:Pb-free G:Green

Note:

Pb-free products:

- ◆ RoHS compliant and compatible with the current requirements of IPC/JEDEC J-STD-020.
- ◆ Suitable for use in SnPb or Pb-free soldering processes with 100% matte tin (Sn) plating.

Green products:

- ◆ Lead-free (RoHS compliant)
- ◆ Halogen free(Br or Cl does not exceed 900ppm by weight in homogeneous material and total of Br and Cl does not exceed 1500ppm by weight)