

System Power PWM Controller for Notebook Computers with Charge Pump

Features

- **Wide Input voltage Range from 6V to 25V**
- **Provide 5 Independent Outputs with $\pm 1.0\%$ Accuracy Over-Temperature**
- **PWM1 Controller with Adjustable (2V to 5.5V) Output**
- **PWM2 Controller with Adjustable (2V to 5.5V) Output**
- **100mA Low Dropout Regulator (LDO5) with Fixed 5V Output**
- **100mA Low Dropout Regulator (LDO3) with Fixed 3.3V Output**
- **270kHz Clock Signal for 15V Charge Pump (Used VOUT1 as Its Power Supply)**
- **Excellent Line/Load Regulations about $\pm 1.5\%$ Over-Temperature Range**
- **Built in POR Control Scheme Implemented**
- **Constant On-Time Control Scheme with Frequency Compensation for PWM Mode**
- **Selectable Switching Frequency in PWM Mode**
- **Built-in Digital Soft-Start for PWM Outputs and Soft-Stop for PWM Outputs and LDO Outputs**
- **Integrated Bootstrap Forward P-CH MOSFET**
- **High Efficiency over Light to Full Load Range (PWMs)**
- **Built-in Power Good Indicators (PWMs)**
- **Independent Enable Inputs (PWMs, LDO)**
- **70% Under-Voltage and 125% Over-Voltage Protections (PWM)**
- **Adjustable Current-Limit Protection (PWMs)**
- **Using Sense Low-Side MOSFET's $R_{DS(ON)}$**
- **Over-Temperature Protection**
- **3mmx3mm Thin QFN-20 (TQFN3x3-20) package**
- **Lead Free and Green Device Available (RoHS Compliant)**

Simplified Application Circuit

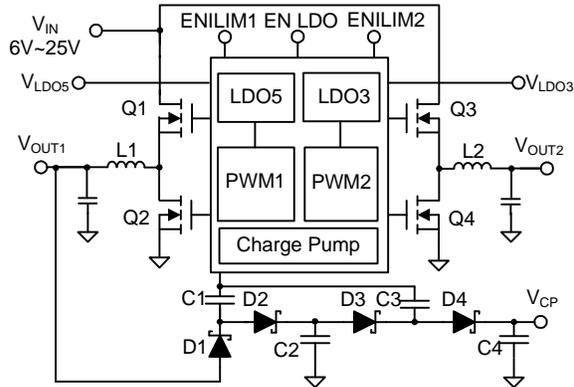

General Description

The APW8822/A/B/C integrates dual step-down, constant-on-time, synchronous PWM controllers (that drives dual N-channel MOSFETs for each channel) and two low dropout regulators as well as various protections into a chip. The PWM controllers step down high voltage of a battery to generate low-voltage for NB applications. The output of PWM1 and PWM2 can be adjusted from 2V to 5.5V by setting a resistive voltage-divider from VOUTx to GND. The linear regulators provide 5V and 3.3V output for standby power supply. The linear regulators provide up to 100mA output current. When the PWMx output voltage is higher than LDOx bypass threshold, the related LDOx regulator is shut off and its output is connected to VOUTx by internal switchover MOSFET. It can save power dissipation. The charge pump circuit with 270kHz clock driver uses VOUT1 as its power supply to generate approximately 15V DC voltage.

The APW8822/A/B/C provides excellent transient response and accurate DC output voltage in either PFM or PWM Mode. In Pulse-Frequency Mode (PFM), the APW8822/A/B/C provides very high efficiency over light to heavy loads with loading-modulated switching frequencies. The Forced-PWM Mode works nearly at constant frequency for low-noise requirements. The unique ultrasonic mode maintains the switching frequency above 25kHz, which eliminates noise in audio application.

ANPEC reserves the right to make changes to improve reliability or manufacturability without notice, and advise customers to obtain the latest version of relevant information to verify before placing orders.

General Description (Cont.)

The APW8822/A/B/C is equipped with accurate sourcing and current-limit, output under-voltage output over-voltage protections, being perfect for NB applications. A 1.4ms (typ.) digital soft-start can reduce the start-up current. A soft-stop function actively discharges the output capacitors by the discharge device. The APW8822/A/B has individual enable controls for each PWM channels. Pulling both EN1/2 pin low shuts down the all of outputs unless LDO3 output. The LDO3 and LDO5 of APW8822A/C are always on standby power. The APW8822/A/B/C is available in a TQFN3x3-20 package.

Applications

- **Notebook and Sub-Notebook Computers**
- **Portable Devices**
- **DDR1, DDR2, and DDR3 Power Supplies**
- **3-Cell and 4-Cell Li+ Battery-Powered Devices**
- **Graphic Cards**
- **Game Consoles**
- **Telecommunications**

Ordering and Marking Information

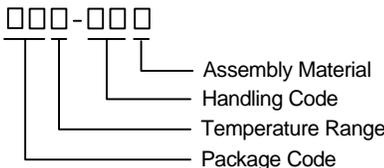
APW8822 APW8822A APW8822B APW8822C		Package Code QB: TQFN3x3-20 Operating Ambient Temperature Range I : -40 to 85°C Handling Code TR : Tape & Reel Lead Free Code L : Lead Free Device G : Halogen and Lead Free Device
APW8822 QB :		XXXXX - Date Code
APW8822A QB :		XXXXX - Date Code
APW8822B QB :		XXXXX - Date Code
APW8822C QB :		XXXXX - Date Code

DEVICE NUMBER	ENABLE FUNCTION	SKIP MODE	ALWAYS ON-LDO
APW8822QB1	EN1/EN2	Auto-skip	LDO3
APW8822AQ1	ENLDO/ENILIM1/ENILIM2	Auto-skip	LDO3 & LDO5
APW8822BQ1	EN1/EN2	Ultra-sonic	LDO3
APW8822CQ1	EN1/EN2	Auto-skip	LDO3 & LDO5

Note: ANPEC lead-free products contain molding compounds/die attach materials and 100% matte tin plate termination finish; which are fully compliant with RoHS. ANPEC lead-free products meet or exceed the lead-free requirements of IPC/JEDEC J-STD-020D for MSL classification at lead-free peak reflow temperature. ANPEC defines "Green" to mean lead-free (RoHS compliant) and halogen free (Br or Cl does not exceed 900ppm by weight in homogeneous material and total of Br and Cl does not exceed 1500ppm by weight).

Pin Configuration

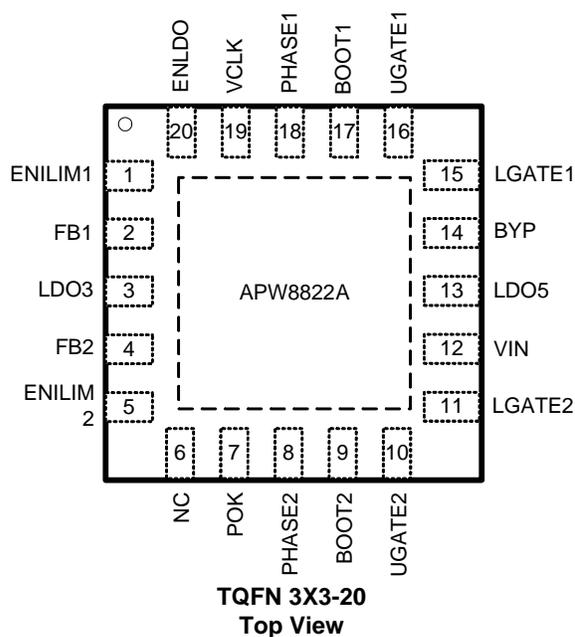
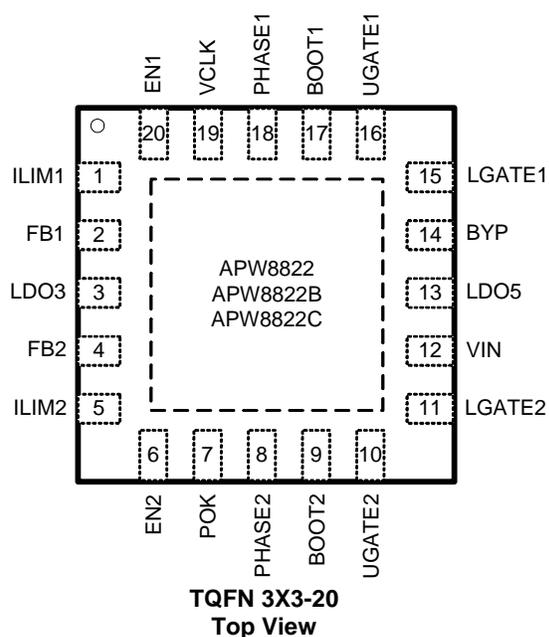

= GND and Thermal Pad (connected to GND plane for better heat dissipation)

Absolute Maximum Ratings (Note 1)

Symbol	Parameter	Rating	Unit
V_{IN}	Input Power Voltage (VIN to GND)	-0.3 ~ 28	V
V_{BOOT}	BOOT Supply Voltage (BOOT to PHASE)	-0.3 ~ 7	V
$V_{BOOT-GND}$	BOOT Supply Voltage (BOOT to GND)	<20ns pulse width >20ns pulse width	V
		-5 ~ 42 -0.3 ~ 35	
$V_{UG-PHASE}$	UGATE Voltage (UGATE to PHASE)	<20ns pulse width >20ns pulse width	V
		-5 ~ $V_{BOOT}+0.3$ -0.3 ~ $V_{BOOT}+0.3$	
V_{LG-GND}	LGATE Voltage (LGATE to GND)	<20ns pulse width >20ns pulse width	V
		-5 ~ $V_{LDO5}+0.3$ -0.3 ~ $V_{LDO5}+0.3$	
V_{PHASE}	PHASE Voltage (PHASE to GND)	<20ns pulse width >20ns pulse width	V
		-5 ~ 35 -0.3 ~ 28	
	All Other Pins (LDOx, FBx, VOUTx, LDO5, LDO3, REF, VCLK, EN LDO, ENILIMx to GND)	-0.3 ~ 6	V
T_J	Maximum Junction Temperature	150	°C
T_{STG}	Storage Temperature	-65 ~ 150	°C
T_{SDR}	Maximum Lead Soldering Temperature, 10 Seconds	260	°C

Note1: Stresses beyond those listed under "absolute maximum ratings" may cause permanent damage to the device. These are stress ratings only and functional operation of the device at these or any other conditions beyond those indicated under "recommended operating conditions" is not implied. Exposure to absolute maximum rating conditions for extended periods may affect device reliability.

Thermal Characteristics (Note 2)

Symbol	Parameter	Typical Value	Unit
θ_{JA}	Thermal Resistance - Junction to Ambient	95	°C/W
θ_{JC}	Thermal Resistance - Junction to Case	60	

Note 2: θ_{JA} is measured with the component mounted on a high effective thermal conductivity test board in free air. The thermal pad of package is soldered directly on the PCB.

Recommended Operating Conditions

Symbol	Parameter	Range	Unit
V_{IN}	PWM1/2 Converter Input Voltage	6 ~ 25	V
V_{OUT1}	PWM1 Converter Output Voltage	2 ~ 5.5	V
V_{OUT2}	PWM2 Converter Output Voltage	2 ~ 5.5	V
C_{IN}	PWM1/2 Converter Input Capacitor (MLCC)	10 ~	μF
C_{LDO}	LDO Output Capacitor (MLCC)	1.0 ~	μF
T_A	Ambient Temperature	-40 ~ 85	°C
T_J	Junction Temperature	-40 ~ 125	°C

Electrical Characteristics

Refer to the typical application circuits. These specifications apply over $V_{IN}=12V$ and $T_A = -40 \sim 85 \text{ }^\circ\text{C}$, unless otherwise specified. Typical values are at $T_A=25^\circ\text{C}$.

Symbol	Parameter	Test Conditions	APW8822			Unit
			Min.	Typ.	Max.	
INPUT SUPPLY POWER						
I_{VN}	VIN Supply Current	Supply current1, $V_{OUT1}=0V$, $EN1=EN2=5V$, $V_{FB1} = V_{FB2} = 2.05V$	-	0.86	1.2	mA
		Supply current2, $V_{OUT1}=5V$, $EN1=EN2=5V$, $V_{FB1} = V_{FB2} = 2.05V$, $P_{VIN}+P_{LDO5}$	-	5	7	mW
		Standby current1, $V_{OUT1}=0V$, $EN1=EN2=0V$ (For APW8822/B)	-	-	80	μA
		Standby current2, $V_{OUT1}=0V$, $EN1=EN2=0V$ (For APW8822A/C)	-	180	245	
		Shutdown current, $ENLDO=0V$, $ENILIMx=0V$ (For APW8822A)	-	20	40	
UNDER-VOLTAGE LOCK OUT PROTECTION (UVLO)						
	LDO5 UVLO threshold	Rising Edge	4.1	4.2	4.3	V
		Hysteresis	-	0.1	-	V
	LDO3 UVLO threshold	Rising Edge	3.0	3.15	3.3	V
		Hysteresis	-	0.8	-	V

Electrical Characteristics

Refer to the typical application circuits. These specifications apply over $V_{IN}=12V$ and $T_A = -40 \sim 85 \text{ }^\circ\text{C}$, unless otherwise specified. Typical values are at $T_A=25^\circ\text{C}$.

Symbol	Parameter	Test Conditions	APW8822			Unit
			Min.	Typ.	Max.	
UNDER-VOLTAGE LOCK OUT PROTECTION (UVLO)						
	VIN POR threshold	Rising threshold1, LDO3 enable	-	3.8	-	V
		Rising threshold1_A/C, LDO3 & LDO5 enable (For APW8822A/C)	-	3.8	-	V
		Rising threshold2, LDO5 enable	-	5.1	-	V
		Falling threshold2, PWMx shutdown with soft stop. When PWMx soft stop is complete, LDO5 will begin to shutdown	-	5.0	-	V
		Falling threshold1, LDOx shutdown with soft stop	-	3.7	-	V
PWM CONTROLLERS						
	Output Voltage Adjust Range	VOUT1, VOUT2	2	-	5.5	V
V_{FB}	FBx Reference Voltage	$T_A = -40^\circ\text{C}$ to 85°C	1.98	2.0	2.02	V
I_{FB}	FBx input current	$V_{FBX}=2.0V, T_A=25^\circ\text{C}$	-20	-	20	nA
T_{SS}	Soft-Start Ramp Time	ENx High to V_{OUT} 95% Regulation, LDO5=5V	-	1.4	-	ms
	Soft-Stop Time	ENx low to $V_{FBX}<0.1V$	-	1.7	-	ms
F_{SW1}	PWM1 Switching Frequency	$V_{IN}=20V, PWM1=5V$	240	300	360	kHz
F_{SW2}	PWM2 Switching Frequency	$V_{IN}=20V, PWM2=3.33V$	280	355	430	
	UGATEx Minimum Off-Time		200	350	500	ns
LOW DROUPT LINEAR REGULATORS (LDO5/LDO3)						
	LDO5 Output Voltage	$V_{OUT1}=GND, 6V<V_{IN}<25V, 0<I_{LDO5}<100mA$	4.8	5.0	5.2	V
	LDO3 Output Voltage	$V_{OUT2}=GND, 6V<V_{IN}<25V, 0<I_{LDO3}<100mA$	3.2	3.33	3.46	V
V_{THBYP5}	LDO5 Bypass Threshold for VOUT1-to-LDO5 Switch On	VOUT1 Regulation Voltage Rising	4.55	4.7	4.85	V
		Hysteresis	0.15	0.25	0.3	
	VOUT1-to-LDO5 Switch On Resistance	$V_{OUT1}=5V, 50mA$	-	1.5	3	Ω
	LDOx Current Limit	$V_{OUTx}=GND, LDOx = GND$	150	250	350	mA
	LDOx Discharge On Resistance	$I_{LDOx}=5mA$	-	50	100	Ω
CHARGE PUMP CLOCK						
V_{CLKH}	High level voltage	$I_{VCLK}=-10mA, LDO5=5V, T_A=25^\circ\text{C}$	-	4.92	-	V
V_{CLKL}	Low level voltage	$I_{VCLK}=10mA, LDO5=5V, T_A=25^\circ\text{C}$	-	0.06	-	
F_{CLK}	Clock frequency	$T_A=25^\circ\text{C}$	-	270	-	kHz
PWM1/2 PROTECTIONS						
	Over Voltage Protection Threshold	V_{FBX} Rising	120	125	130	%
	Over Voltage Fault Propagation Delay	Delta voltage=10mV	-	3	-	μs
	Current Limit Current Source	$V_{ILIMx}=1V, T_A = 25^\circ\text{C}$	9	10	11	μA
		On the basis of 25°C	-	4500	-	ppm/ $^\circ\text{C}$

Electrical Characteristics (Cont.)

Refer to the typical application circuits. These specifications apply over $V_{IN}=12V$ and $T_A = -40 \sim 85 \text{ }^\circ\text{C}$, unless otherwise specified. Typical values are at $T_A=25^\circ\text{C}$.

Symbol	Parameter	Test Conditions	APW8822			Unit
			Min.	Typ.	Max.	
PWM1/2 PROTECTIONS						
	ILIMx Adjustment Range	$V_{ILIMx-GND}$	0.2	-	2	V
	ENILIMx Adjustment Range	$V_{ENILIMx-GND}$	0.515	-	2	V
	Maximum setting voltage	$V_{ILIMx} = 5V$, Setting Current Limit Threshpld	205	250	-	mV
	Current limit comparator offset	$(V_{ILIMx-GND} - V_{PGND-PHASEx})$, $V_{ILIMx}=920mV$	-8	0	8	mV
	Zero-Crossing Threshold	$V_{PGND} - PHASE$	-5	0	5	mV
	Under-Voltage Protection Threshold		65	70	75	%
	Under-Voltage Protection Debounce Interval		-	25	-	μs
	Under-Voltage Protection Enable Blanking Time	From EN signal go high to SS_OK	-	2	-	ms
	Over-Temperature Protection Threshold	T_J Rising	-	160	-	$^\circ\text{C}$
		Hysteresis	-	25	-	
POWER GOOD						
	POK Threshold	POK in from Lower (POK goes high)	87	90	93	%
		POK hysteresis	-	3	-	
		POK in from higher (POK goes low)	120	125	130	
	POK Propagation Delay		-	63	-	μs
	POK Enable Delay	From EN signal go high to POK go High	-	2	-	ms
	POK Sink current	$V_{POK} = 500mV$	2.5	7.5		mA
	POK Leakage Current	$V_{POK} = 5V$	-	0.1	1	μA
LOGIC LEVELS						
	ENx Input Voltage Level	Enable	-	-	1.2	V
		Shutdown	0.6	-	-	
	Input leakage current	$V_{EN}=5V$		0.1	1	μA
	ENILIMx Input Voltage	Enable	300	400	500	mV
		Hysteresis	-	60	-	
	ENLDO Input Voltage	Shutdown	-	-	0.4	V
		Enable, VCLK=off	0.8	-	1.6	
		Enable, VCLK=on	2.4	-	-	
	ENLDO pin pull high function	Short Current, ENLDO is short to GND	-	1	-	μA
		Open Voltage, ENLDO is open(pull high to internal regulator)	2.4	3.34	-	

Electrical Characteristics (Cont.)

Refer to the typical application circuits. These specifications apply over $V_{IN}=12V$ and $T_A = -40 \sim 85 \text{ }^\circ\text{C}$, unless otherwise specified. Typical values are at $T_A=25^\circ\text{C}$.

Symbol	Parameter	Test Conditions	APW8822			Unit
			Min.	Typ.	Max.	
GATE DRIVERS						
	UG Pull-Up Resistance	$V_{BOOTx} - V_{UGATEx}=250mV$	-	3	5	Ω
	UG Sink Resistance	$V_{UGATEx} - V_{PHASEx}=250mV$	-	1.7	2.5	Ω
	LG Pull-Up Resistance	$V_{LDO5} - V_{LGATEx}=250mV$	-	3	5	Ω
	LG Sink Resistance	$V_{LGATEx} - V_{PGND}=250mV$	-	1	2	Ω
	Dead Time	UG falling to LG rising	-	20	-	ns
		LG falling to UG rising	-	20	-	ns
BOOTSTRAP SWITCH						
V_F	Forward Voltage	$V_{LDO5} - V_{BOOTx-GND}, I_F = 10mA$	-	0.4	0.5	V
I_R	Reverse Leakage	$V_{BOOTx-GND} = 30V, V_{PHASEx} = 25V,$ $V_{LDO5} = 5V$	-	-	0.5	μA

Typical Operating Characteristics

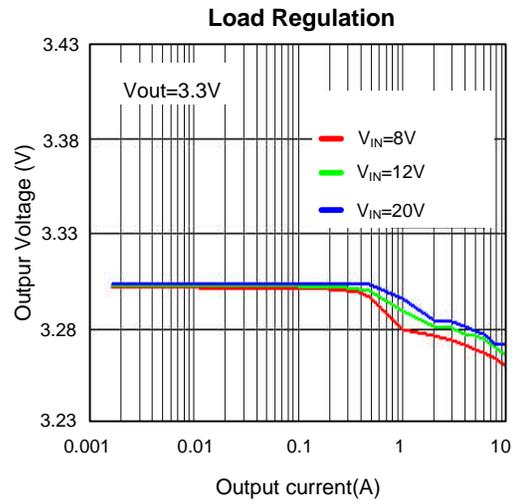
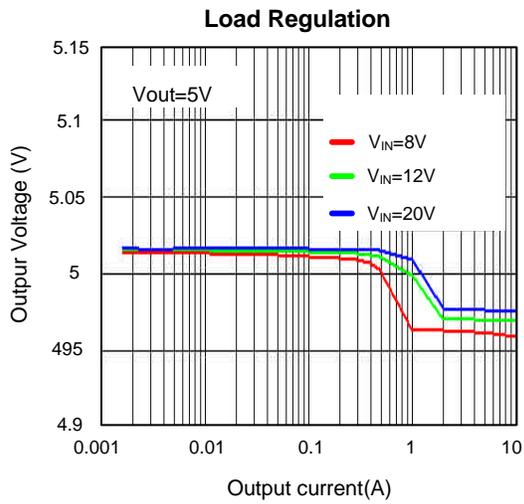

Operating Waveforms

Refer to the typical application circuit. The test condition is $V_{IN}=12V$, $T_A=25^{\circ}C$ unless otherwise specified.

Start-Up

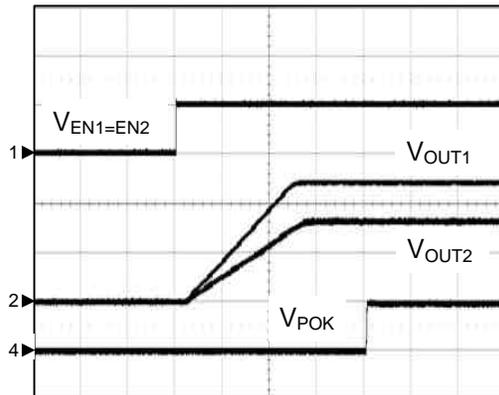

CH1: EN1=EN2, 5V/Div
 CH2: V_{OUT1}, 2V/Div
 CH3: V_{OUT2}, 2V/Div
 CH4: V_{POK}, 10V/Div
 TIME: 500us/Div

Output-Discharge

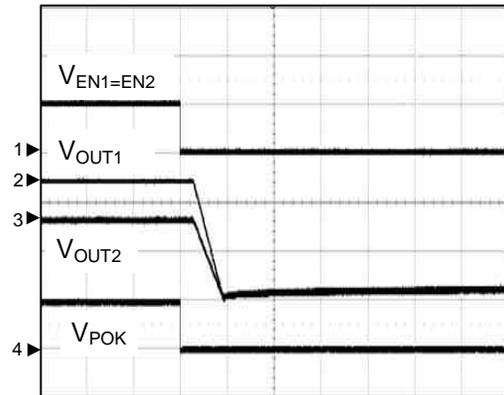

CH1: EN1=EN2, 5V/Div
 CH2: V_{OUT1}, 2V/Div
 CH3: V_{OUT2}, 2V/Div
 CH4: V_{POK}, 10V/Div
 TIME: 500us/Div

5V Load Transient

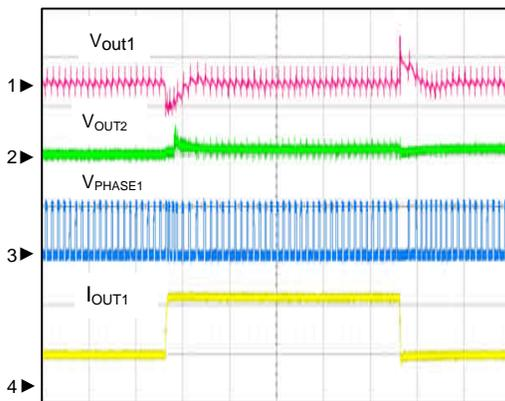

CH1: Vout1, 100mV/Div, AC
 CH2: Vout2, 100mV/Div, AC
 CH3: V_{PHASE1}, 20V/Div, DC
 CH4: I_{OUT1}, 5A/Div
 TIME: 20us/Div

3.3V Load Transient

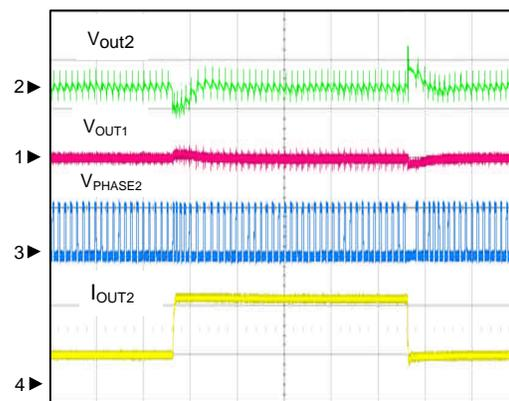

CH1: Vout1, 100mV/Div, AC
 CH2: Vout2, 100mV/Div, AC
 CH3: V_{PHASE2}, 20V/Div, DC
 CH4: I_{OUT2}, 5A/Div
 TIME: 20us/Div

Pin Description

PIN		NAME	FUNCTION
NO.			
APW8822/B/C	APW8822A		
1	-	ILIM1	Current Limit Adjustment. There is an internal 10 μ A current source from LDO5 to ILIM1 and connected a resistor from ILIM1 to GND to set the current limit threshold. The PGND-PHASE1 current-limit threshold is 1/8 th the voltage set at ILIM1 over a 0.2 to 2V range. The logic current limit threshold is default to 250mV value if ILIM1 is 5V.
-	1	ENILIM1	PWM1 Enable and Current Limit Adjustment. There is an internal 10 μ A current source from LDO5 to ENILIM1 and connected a resistor from ENILIM1 to GND to set the current limit threshold. The PGND-PHASE1 current-limit threshold is 1/8 th the voltage set at ENILIM1 over a 0.515 to 2V range. The logic current limit threshold is default to 250mV value if ENILIM1 is 5V. PWM1 and VCLK are enabled when ENILIM1=1. When ENILIM1=0, PWM1 and VCLK are in shutdown.
2	2	FB1	Output voltage feedback pin (PWM1). It can use a resistive divider from VOUT1 to GND to adjust the output from 2V to 5.5V.
3	3	LDO3	3.3V Linear Regulator Output. LDO3 can provide a total of 100mA, 3.3V external loads. Bypass to GND with a minimum of 1.0 μ F ceramic capacitor for stability.
4	4	FB2	Output voltage feedback pin (PWM2). It can use a resistive divider from VOUT2 to GND to adjust the output from 2V to 5.5V.
5	-	ILIM2	Current Limit Adjustment. There is an internal 10 μ A current source from LDO5 to ILIM2 and connected a resistor from ILIM2 to GND to set the current limit threshold. The PGND-PHASE2 current-limit threshold is 1/8 th the voltage set at ILIM2 over a 0.2 to 2V range. The logic current limit threshold is default to 250mV value if ILIM2 is 5V.
-	5	ENILIM2	PWM2 Enable and Current Limit Adjustment. There is an internal 10 μ A current source from LDO5 to ENILIM2 and connected a resistor from ENILIM2 to GND to set the current limit threshold. The PGND-PHASE2 current-limit threshold is 1/8 th the voltage set at ENILIM2 over a 0.515 to 2V range. The logic current limit threshold is default to 250mV value if ENILIM2 is 5V. PWM2 is enabled when ENILIM2=1. When ENILIM2=0, PWM2 is in shutdown.
6	-	EN2	PWM2 Enable. PWM2 is enabled when EN2=1. When EN2=0, PWM2 is in shutdown.
-	6	NC	No Connection
7	7	POK	Power-Good Output Pin of Both PWMs (Logic AND). POK is an open-drain output used to indicate the status of the PWMx output voltage. Connect the POK in to +5V through a pull-high resistor.
8	8	PHASE2	Junction Point of The High-Side MOSFET Source, Output Filter Inductor and The Low-Side MOSFET Drain for PWM2. Connect this pin to the Source of the high-side MOSFET. PHASE2 serves as the lower supply rail for the UGATE2 high-side gate driver. PHASE2 is the current-sense input for the PWM2.
9	9	BOOT2	Supply Input for The UGATE2 Gate Driver and an internal level-shift circuit. Connect to an external capacitor to create a boosted voltage suitable to drive a logic-level N-channel MOSFET.
10	10	UGATE2	Output of The High-Side MOSFET Driver for PWM2. Connect this pin to Gate of the high-side MOSFET.

Pin Description (Cont.)

PIN		NAME	FUNCTION
NO.			
APW8822/B/C	APW8822A		
11	11	LGATE2	Output of The Low-Side MOSFET Driver for PWM2. Connect this pin to Gate of the low-side MOSFET. Swings from PGND to LDO5.
12	12	VIN	Battery voltage input pin. VIN powers linear regulators and is also used for the constant on-time PWM on-time one-shot circuits. Connect VIN to the battery input and bypass with a 1 μ F capacitor for noise interference.
13	13	LDO5	5V Linear Regulator Output. LDO5 can provide a total of 100mA, 5V external loads. When LDO5 is at 5V and PWM1 output voltage is over 4.7V bypass threshold, the internal LDO will shut down, and LDO5 output pin connects to VOUT1 through a 1.5 Ω switch. Bypass to GND with a minimum of 1.0 μ F ceramic capacitor for stability.
14	14	BYP	BYP is the input pin of switchover voltage for the LDO5. This pin makes a direct measurement of the PWM1 output voltage.
15	15	LGATE1	Output of The Low-Side MOSFET Driver for PWM1. Connect this pin to Gate of the low-side MOSFET. Swings from PGND to LDO5.
16	16	UGATE1	Output of The High-Side MOSFET Driver for PWM1. Connect this pin to Gate of the high-side MOSFET.
17	17	BOOT1	Supply Input for The UGATE1 Gate Driver and an internal level-shift circuit. Connect to an external capacitor to create a boosted voltage suitable to drive a logic-level N-channel MOSFET.
18	18	PHASE1	Junction Point of The High-Side MOSFET Source, Output Filter Inductor and The Low-Side MOSFET Drain for PWM1. Connect this pin to the Source of the high-side MOSFET. PHASE1 serves as the lower supply rail for the UGATE1 high-side gate driver. PHASE1 is the current-sense input for the PWM1.
19	19	VCLK	250kHz Clock Output for 15V Charge Pump.
20	-	EN1	PWM1 Enable. PWM1 is enabled when EN1=1. When EN1=0, PWM1 is in shutdown.
-	20	ENLDO	Master Enable Input. The LDOx is enabled when ENLDO=1. When ENLDO=0, the LDOx is shutdown. See the table2 "Power-Up Control Logics".
Thermal Pad	Thermal Pad	GND	Signal Ground for The IC.

Block Diagram

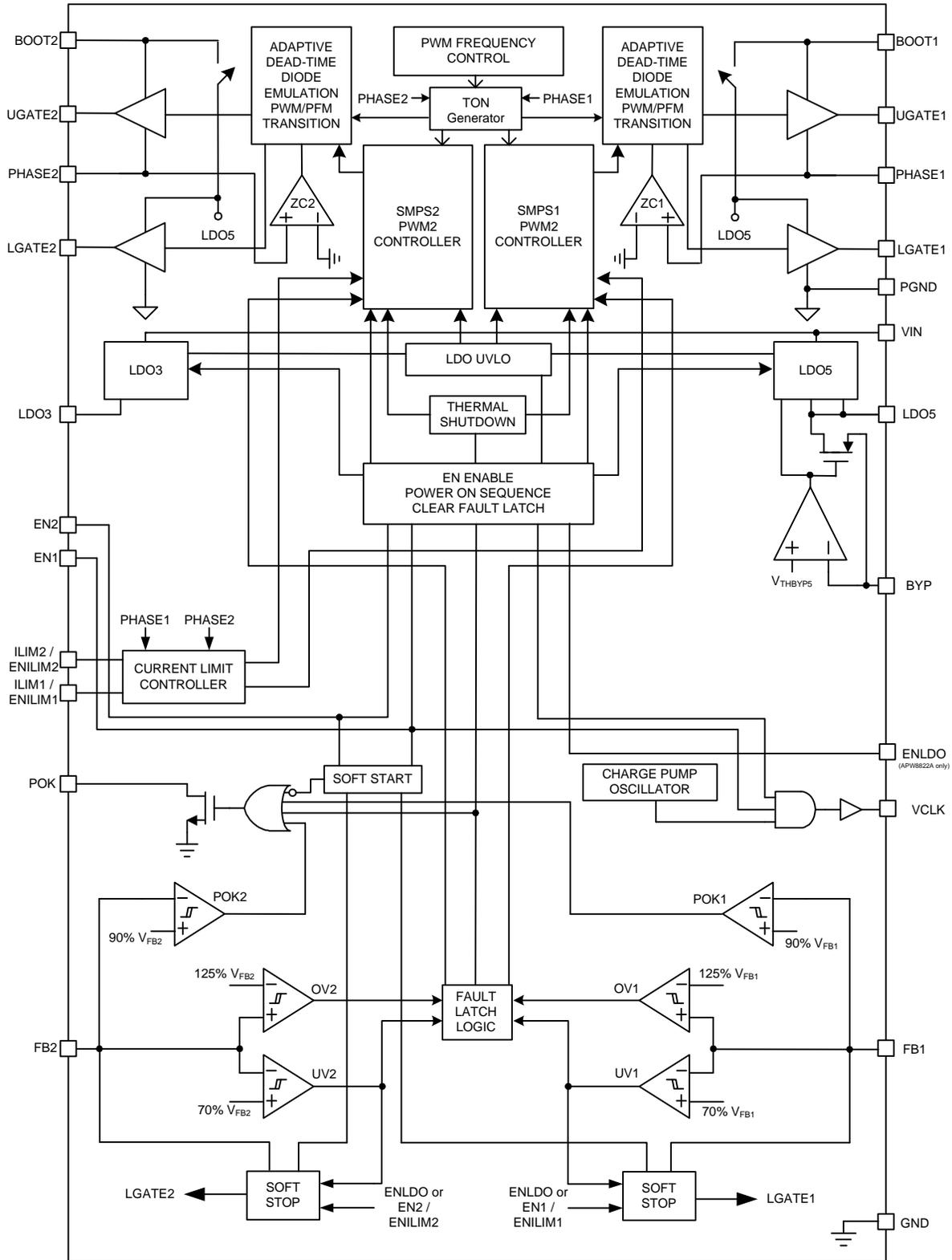

Typical Application Circuit

For APW8822/B/C

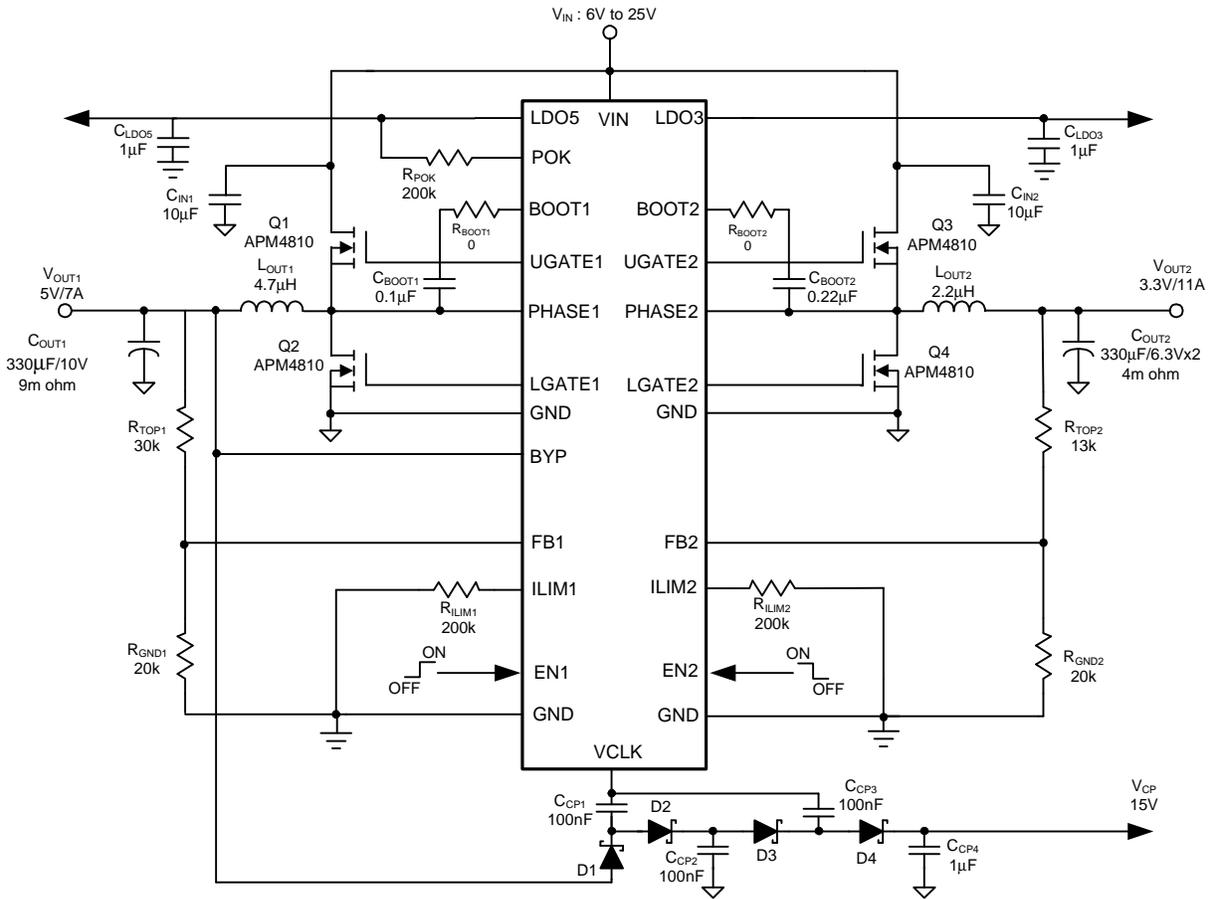

Typical Application Circuit

For APW8822A

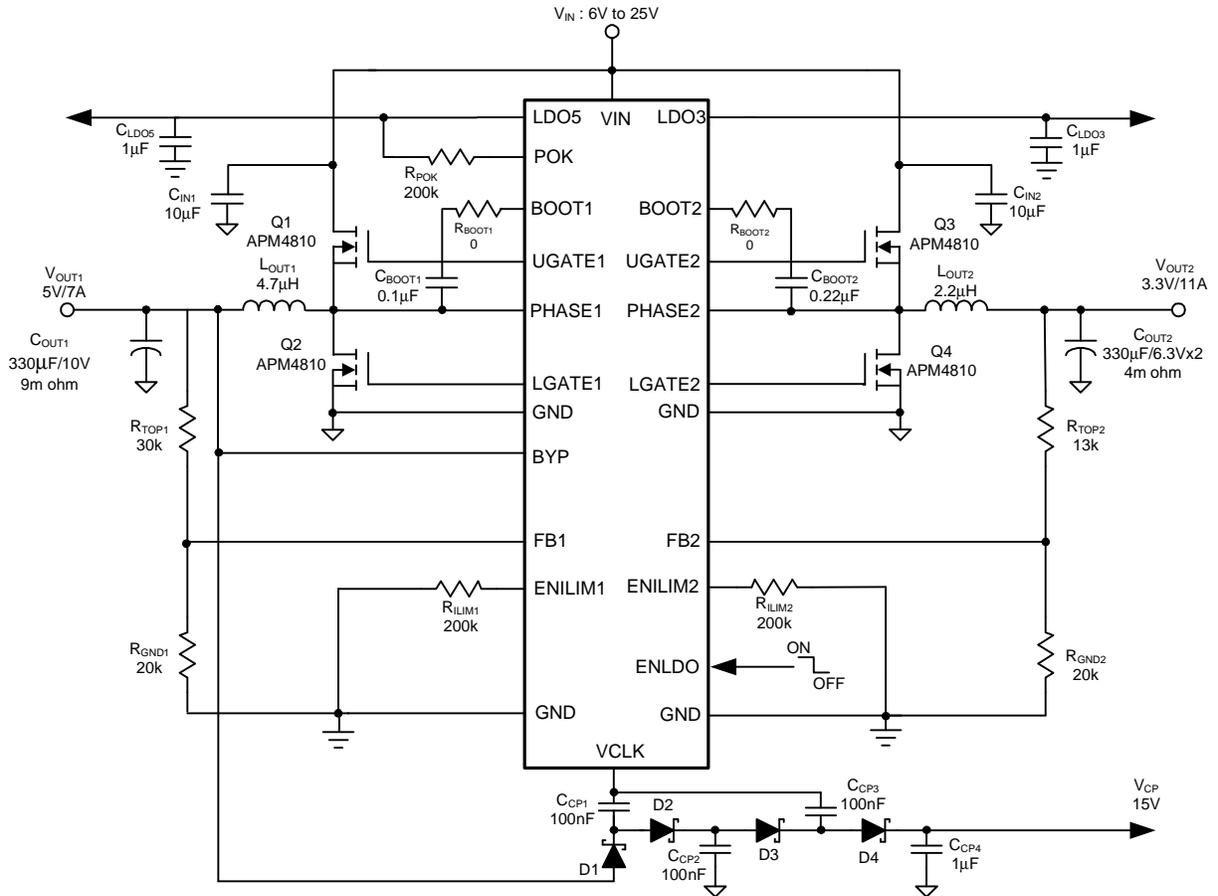

Function Description

Constant-On-Time PWM Controller with Input Feed-Forward

The constant-on-time control architecture is a pseudo-fixed frequency with input voltage feed-forward. This architecture relies on the output filter capacitor's effective series resistance (ESR) to act as a current-sense resistor, so the output ripple voltage provides the PWM ramp signal. In PFM operation, the high-side switch on-time controlled by the on-time generator is determined solely by a one-shot whose pulse width is inversely proportional to input voltage and directly proportional to output voltage. In PWM operation, the high-side switch on-time is determined by a switching frequency control circuit in the on-time generator block. The switching frequency control circuit senses the switching frequency of the high-side switch and keeps regulating it at a constant frequency in PWM mode. The design improves the frequency variation and is more outstanding than a conventional constant-on-time controller, which has large switching frequency variation over input voltage, output current and temperature. Both in PFM and PWM, the on-time generator, which senses input voltage on VIN pin, provides very fast on-time response to input line transients.

Another one-shot sets a minimum off-time (typ.: 350ns). The on-time one-shot is triggered if the error comparator is high, the low-side switch current is below the current-limit threshold, and the minimum off-time one-shot has timed out.

Pulse-Frequency Modulation (PFM) Mode

In PFM mode, an automatic switchover to pulse-frequency modulation (PFM) takes place at light loads. This switchover is affected by a comparator that truncates the low-side switch on-time at the inductor current zero crossing. This mechanism causes the threshold between PFM and PWM operation to coincide with the boundary between continuous and discontinuous inductor-current operation (also known as the critical conduction point). The on-time of PFM is given by:

$$T_{ON-PFM} = \frac{1}{F_{SW}} \times \frac{V_{OUT}}{V_{IN}}$$

Where F_{SW} is the nominal switching frequency of the converter in PWM mode. Similarly, the on-time of ultrasonic mode is the same with PFM mode. The description of ultrasonic mode will be illustrated later.

The load current at handoff from PFM to PWM mode is given by:

$$\begin{aligned} I_{LOAD(PFM\ to\ PWM)} &= \frac{1}{2} \times \frac{V_{IN} - V_{OUT}}{L} \times T_{ON-PFM} \\ &= \frac{V_{IN} - V_{OUT}}{2L} \times \frac{1}{F_{SW}} \times \frac{V_{OUT}}{V_{IN}} \end{aligned}$$

Linear Regulator (LDO3 and LDO5)

The LDO3 and LDO5 regulators can supply up to 100mA for external loads. Bypass to GND with a minimum of 1uF ceramic capacitor for stability. For APW8822A, when ENLDO is enabled, the VLDO3 is fixed 3.33V and the VLDO5 is fixed 5V in standby mode. For APW8822C, When VIN reaches POR rising threshold, the VLDO3 is fixed 3.33V and the VLDO5 is fixed 5V in standby mode. Let us see the table2"Power-Up Control Logic" for the detail description about standby mode. For all of APW8822 series, When PWM1 output voltage is over whose bypass threshold (PWM1 is 4.7V), the internal LDO5 to VOUT1 switchover is active. These actions change the current path to power the loads from the PWM regulator voltage, rather than from the internal linear regulator.

Power -On-Reset

A Power-On-Reset (POR) function is designed to prevent wrong logic controls. The POR function continually monitors the supply voltage on the LDO5 pins. LDO5 POR circuitry inhibits wrong switching. When the rising VLDO5 voltage reaches the rising POR threshold (4.3V typical), the PWM output voltages begin to ramp up. When the LDO5 voltage is lower than 4.2V(typ.) or LDO3 voltage is lower than 2.374V(typ.), both switch power supplies are shut off. This is non-latch protection. LDO5 POR threshold could reset the under-voltage, over-voltage.

Function Description (Cont.)

Soft Start

The APW8822/A/B/C integrates soft-start circuit to ramp up the PWMx output voltage of the converter to the programmed regulation set point at a predictable slew rate. The slew rate of PWMx output voltage is internally controlled to limit the inrush current through the output capacitors during soft start process. When the ENx pin is pulled above the rising threshold voltage, the related PWM initiates a soft-start process to ramp up the output voltage. The soft-start interval is 1.4ms(typical) and independent of the UGATE switching frequency.

Enable Controls

The APW8822/A/B/C has two independent enable controls for PWM part. When the ENx pin is high (ENLIMx=1) at standby mode, the PWMx initiates a soft-start process to ramp up the output voltage. The PWM1 and PWM2 are controlled individually by EN1 and EN2. When EN1 and EN2 are both low, the chip is in its low-power standby state. The APW8822/B only consumes 80 μ A of current while in standby mode.

When the EN1 is high, the clock signal becomes available from VCLK pin. Both PWM outputs are discharged to low voltage by the soft stop method and both LDO outputs are discharged to 0V through a 50 Ω switch in soft stop state. Driving EN1 and EN2 (logic AND) below low threshold clears the over-voltage, and under-voltage fault latches.

Charge Pump

The condition of the 270kHz clock signal can be used is that the EN1 is high. When VOUT1 regulates at 5V and the clock signal uses VOUT1 as its power supply, the charge pump circuit can generate 15V DC voltage approximately. The example of charge pump circuit is shown in typical application circuit.

Soft-Stop (PWMs)

In the event of PWM under-voltage or shutdown, the chip enables the soft-stop function. The soft-stop function discharges the PWM output voltages to low voltage by the soft stop method. The reference remains active to provide an accurate threshold and to provide over-voltage protection.

Power Good Indicator (PWMs)

POK is actively held low in shutdown, standby, and soft-start. In the soft-start process, the POK is an open-drain output, and it is released with enable delay after the latest ENx goes high (about 2ms typ.). In normal operation, the POK window is from 90% to its OVP threshold of the converter reference voltage. Both of VOUT1 and VOUT2 have to stay within this window for POK to be high (AND gated). In order to prevent false POK drop, capacitors need to parallel at the output to confine the voltage deviation with severe load step transient.

Under-Voltage Protection (PWMs)

In the process of operation, if a short-circuit occurs, the output voltage will drop quickly. When load current is bigger than current limit threshold value, the output voltage will fall out of the required regulation range. The under-voltage continually monitors the setting output voltage after soft-start is completed. If a load step is strong enough to pull the output voltage lower than the under-voltage threshold for at least 25 μ s, the PWM controller starts a soft-stop process to shut down the output gradually. As long as either of PWM channels triggers under-voltage, both of PWM channels active under-voltage protection and latched off when the soft-stop process is completed. The under-voltage threshold is 70% of the nominal output voltage. Under-voltage protection is ignored for at least 2ms (typical) after a rising edge on EN. Re-toggling EN1 and EN2 (logic AND) signal will clear the latch and bring the chip back to operation.

Function Description (Cont.)

Over Voltage Protection (OVP)

Should the output voltage of VOUT1 and VOUT2 increase over 25% of the setting voltage due to the high-side MOSFET failure or for other reasons, the over voltage protection will active. As long as either of PWM channels triggers over voltage, the other PWM channel will be soft stop state. Over voltage protection will force the low-side MOSFET gate driver fully turn on. This action actively pulls down the output voltage. When the OVP occurs, the POK pin will pull down and latch-off the converter. This OVP scheme only clamps the voltage overshoot, and does not invert the output voltage when otherwise activated with a continuously high output from low-side MOSFET driver. It's a common problem for OVP schemes with a latch. Once an over-voltage fault condition is set, it can be reset by re-toggling EN1 and EN2 (logic AND) signal.

Over-Temperature Protection

When the junction temperature increases above the rising threshold temperature 160°C, the IC will enter the over temperature protection (OTP). When the OTP occurs, LDO and PWM controllers circuitry shuts down. It is non-latch protection.

Current Limit (PWMs)

The current limit circuit employs a "valley" current-sensing algorithm (See Figure 1). The APW8822/A/B/C uses the low-side MOSFET's $R_{DS(ON)}$ of the synchronous rectifier as a current-sensing element. If the magnitude of the current-sense signal at PHASE pin is above the current-limit threshold, the PWM is not allowed to initiate a new cycle. The actual peak current is greater than the current-limit threshold by an amount equal to the inductor ripple current. Therefore, the exact current-limit characteristic and maximum load capability are a function of the sense resistance, inductor value, and input voltage.

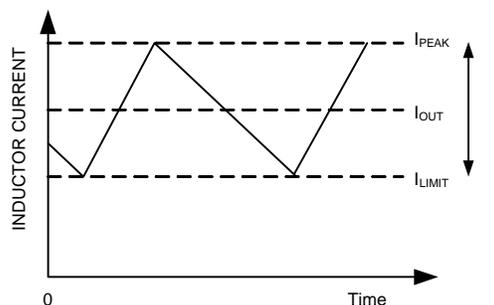

Figure 1. Current-Limit Algorithm

Both PWM controllers use the low-side MOSFETs on-resistance $R_{DS(ON)}$ to monitor the current for protection against shorted outputs. The MOSFET's $R_{DS(ON)}$ is varied by temperature and gate to source voltage, the user should determine the maximum $R_{DS(ON)}$ in manufacture's datasheet.

The current Limit threshold of APW8822/A/B/C is adjusted with an external resistor. For APW8822A, the ENILIMx pin adjustment range is from 515mV to 2V. In the adjustable mode, the current-limit threshold voltage is 1/8th the voltage at ILIMx pin. As shown in Figure 2, The ILIMx pin can source 10μA. The voltage at ILIMx pin is equal to 10μA x RILIM. The logic current limit threshold is default to 250mV value if voltage at ILIMx pin is above 2V(ENILIMx is 5V). The relationship between the sampled voltage VILIM and the current limit threshold ILIMIT is given by:

$$\frac{1}{8} \times V_{ILIMX} = I_{LIMIT} \times R_{DS(ON)} \quad \text{---APW8822/B/C}$$

$$\frac{1}{8} \times V_{ENILIMX} = I_{LIMIT} \times R_{DS(ON)} \quad \text{---APW8822A}$$

Where VILIMX is the voltage at the ILIMx pin. RDS(ON) is the low side MOSFETs conductive resistance. ILIMIT is the setting current limit threshold. ILIMIT can be expressed as IOUT minus half of peak-to-peak inductor current.

The PCB layout guidelines should ensure that noise and DC errors do not corrupt the current-sense signals at PHASE. Place the hottest power MOSEFTs as close to the IC as possible for best thermal coupling. When combined with the under-voltage protection circuit, this current-limit method is effective in almost every circumstance.

Function Description (Cont.)

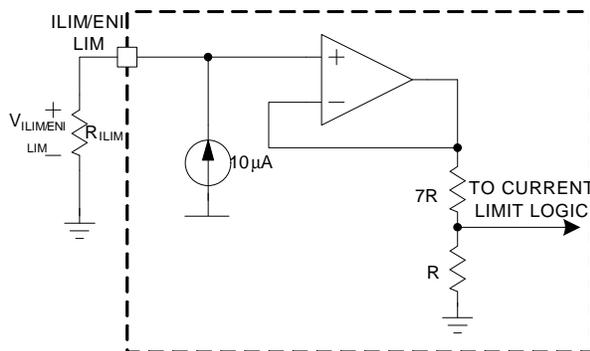

Figure 2. Current-Limit Setting Block Diagram

Table 1. Operating Mode Truth Table

MODE	CONDITION		COMMENT
Run	APW8822/B/C	ENx = 1	PWM is in normal operation.
	APW8822A	ENLDO = 1, ENILIMx = 1	
Standby & Soft Stop	APW8822/B	ENx = 0	PWMx is in shutdown with soft stop, and then LDO5 is also in shutdown with discharge function after soft stop function in PWMx is completed. LDO3 is active.
	APW8822C	ENx=0	PWMx is in shutdown with soft stop function. LDO3 and LDO5 are active.
	APW8822A	ENILIMx=0, ENLDO=1	PWMx is in shutdown with soft stop function. LDO3 and LDO5 are active.
Shutdown	APW8822/B/C	-	-
	APW8822A	ENLDO=0	PWMx is in shutdown with soft stop, and then LDOx is also in shutdown with discharge function after soft stop function in PWMx is completed. In this mode, all circuitry is off.
UVP	Either V_{OUT1} , or $V_{OUT2} < 70\%$ of nominal output voltage		The soft stop function will enable to pull low output voltage. LDOx is active. Reset by toggling EN1 and EN2 (logic AND). This action will re-start LDO5 at the same time. (For APW8822/B).
OVP	Either V_{OUT1} and $V_{OUT2} > 125\%$ of normal output voltage		LGATE of the PWM channel, which occurs OVP event is forced high, the other PWM channel is in shutdown with soft stop. LDOx is active. Reset by toggling EN1 and EN2 (logic AND). This action will re-start LDO5 at the same time. (For APW8822/B).
OTP	$T_J > +160^\circ C$		All circuitry off. It is non-latch protection after the junction temperature cools by $25^\circ C$.

Function Description (Cont.)

Table 2. Power-Up Control Logics

For APW8822/B

V _{EN1}	V _{EN2}	LDO5	LDO3	PWM1	PWM2	VCLK
Low	Low	OFF	ON	OFF	OFF	OFF
High	High	ON	ON	ON	ON	ON
High	Low	ON	ON	ON	OFF	ON
Low	High	ON	ON	OFF	ON	OFF

For APW8822C

V _{EN1}	V _{EN2}	LDO5	LDO3	PWM1	PWM2	VCLK
Low	Low	ON	ON	OFF	OFF	OFF
High	High	ON	ON	ON	ON	ON
High	Low	ON	ON	ON	OFF	ON
Low	High	ON	ON	OFF	ON	OFF

For APW8822A

V _{ENLDO}	V _{ENILIM1}	V _{ENILIM2}	LDO5	LDO3	PWM1	PWM2	VCLK
Low	Don't Care	Don't Care	OFF	OFF	OFF	OFF	OFF
0.8V~1.6V	Low	Low	ON	ON	OFF	OFF	OFF
0.8V~1.6V	High	High	ON	ON	ON	ON	OFF
0.8V~1.6V	High	Low	ON	ON	ON	OFF	OFF
0.8V~1.6V	Low	High	ON	ON	OFF	ON	OFF
>2.4V	Low	Low	ON	ON	OFF	OFF	OFF
>2.4V	High	High	ON	ON	ON	ON	ON
>2.4V	High	Low	ON	ON	ON	OFF	ON
>2.4V	Low	High	ON	ON	OFF	ON	OFF

Application Information

Output Voltage Selection

The output voltage of PWM1 can be adjusted from 2V to 5.5V with a resistor-driver at FB1 between V_{OUT1} and GND. Using 1% or better resistors for the resistive divider is recommended. The FB1 pin is the inverter input of the error amplifier, and the reference voltage is 2V. Take the example, the output voltage of PWM1 is determined by:

$$V_{OUT1} = 2 \times \left(1 + \frac{R_{TOP1}}{R_{GND1}} \right)$$

Where R_{TOP1} is the resistor connected from V_{OUT1} to V_{FB1} and R_{GND1} is the resistor connected from FB1 to GND. Similarly, the output voltage of PWM2 can be also adjusted from 2V to 5.5V.

Output Inductor Selection

The duty cycle of a buck converter is the function of the input voltage and output voltage. Once an output voltage is fixed, it can be written as:

$$D = \frac{V_{OUT}}{V_{IN}}$$

The inductor value determines the inductor ripple current and affects the load transient response. Higher inductor value reduces the inductor's ripple current and induces lower output ripple voltage. The ripple current can be approximated by:

$$I_{RIPPLE} = \frac{V_{IN} - V_{OUT}}{F_{SW} \times L} \times \frac{V_{OUT}}{V_{IN}}$$

Where F_{SW} is the switching frequency of the regulator. Increasing the inductor value and frequency will reduce the ripple current and voltage. However, there is a tradeoff between the inductor's ripple current and the regulator load transient response time.

A smaller inductor will give the regulator a faster load transient response at the expense of higher ripple current. Increasing the switching frequency (F_{SW}) also reduces the ripple current and voltage, but it will increase the switching loss of the MOSFETs and the power dissipation of the converter. The maximum

ripple current occurs at the maximum input voltage. A good starting point is to choose the ripple current to be approximately 30% of the maximum output current. Once the inductance value has been chosen, selecting an inductor is capable of carrying the required peak current without going into saturation. In some types of inductors, especially core that is made of ferrite, the ripple current will increase abruptly when it saturates. This will be result in a larger output ripple voltage.

Output Capacitor Selection

Output voltage ripple and the transient voltage deviation are factors that have to be taken into consideration when selecting an output capacitor. Higher capacitor value and lower ESR reduce the output ripple and the load transient drop. Therefore, selecting high performance low ESR capacitors is intended for switching regulator applications. In addition to high frequency noise related MOSFET turn-on and turn-off, the output voltage ripple includes the capacitance voltage drop and ESR voltage drop caused by the AC peak-to-peak current. These two voltages can be represented by:

$$\Delta V_{COUT} = \frac{I_{RIPPLE}}{8C_{OUT}F_{SW}}$$

$$\Delta V_{ESR} = I_{RIPPLE} \times R_{ESR}$$

These two components constitute a large portion of the total output voltage ripple. In some applications, multiple capacitors have to be paralleled to achieve the desired ESR value. If the output of the converter has to support another load with high pulsating current, more capacitors are needed in order to reduce the equivalent ESR and suppress the voltage ripple to a tolerable level. A small decoupling capacitor in parallel for bypassing the noise is also recommended, and the voltage rating of the output capacitors must also be considered.

To support a load transient that is faster than the switching frequency, more capacitors have to be used to reduce the voltage excursion during load step change. Another aspect of the capacitor selection is that the total AC current going through the capacitors has to be less than the rated RMS current specified on the capacitors to prevent the capacitor from over-heating.

Application Information (Cont.)

Input Capacitor Selection

The input capacitor is chosen based on the voltage rating and the RMS current rating. For reliable operation, select the capacitor voltage rating to be at least 1.3 times higher than the maximum input voltage. The maximum RMS current rating requirement is approximately $I_{OUT}/2$, where I_{OUT} is the load current. During power up, the input capacitors have to handle large amount of surge current. In low-duty notebook applications, ceramic capacitors are recommended. The capacitors must be connected between the drain of high-side MOSFET and the source of low-side MOSFET with very low-impedance PCB layout.

MOSFET Selection

The application for a notebook battery with a maximum voltage of 24V, at least a minimum 30V MOSFETs should be used. The design has to trade off the gate charge with the $R_{DS(ON)}$ of the MOSFET:

- For the low-side MOSFET, before it is turned on, the body diode has been conducted. The low-side MOSFET driver will not charge the miller capacitor of this MOSFET.
- In the turning off process of the low-side MOSFET, the load current will shift to the body diode first. The high dv/dt of the phase node voltage will charge the miller capacitor through the low-side MOSFET driver sinking current path. This results in much less switching loss of the low-side MOSFETs. The duty cycle is often very small in high battery voltage applications, and the low-side MOSFET will conduct most of the switching cycle; therefore, the less the $R_{DS(ON)}$ of the low-side MOSFET, the less the power loss. The gate charge for this MOSFET is usually a secondary consideration. The high-side MOSFET does not have this zero voltage switching condition, and because it conducts for less time compared to the low-side MOSFET, the switching loss tends to be dominant. Priority should be given to the MOSFETs with less gate charge, so that both the gate driver loss and switching loss will be minimized.

The selection of the N-channel power MOSFETs are determined by the $R_{DS(ON)}$, reversing transfer capacitance

(C_{RSS}) and maximum output current requirement. The losses in the MOSFETs have two components: conduction loss and transition loss. For the high-side and low-side MOSFETs, the losses are approximately given by the following equations:

$$P_{\text{high-side}} = I_{OUT}^2 (1+TC)(R_{DS(ON)})D + (0.5)(I_{OUT})(V_{IN})(t_{SW})F_{SW}$$

$$P_{\text{low-side}} = I_{OUT}^2 (1+TC)(R_{DS(ON)})(1-D)$$

Where

I_{OUT} is the load current

TC is the temperature dependency of $R_{DS(ON)}$

F_{SW} is the switching frequency

t_{SW} is the switching interval

D is the duty cycle

Note that both MOSFETs have conduction losses while the high-side MOSFET includes an additional transition loss. The switching interval, t_{SW} , is the function of the reverse transfer capacitance C_{RSS} . The (1+TC) term is to factor in the temperature dependency of the $R_{DS(ON)}$ and can be extracted from the " $R_{DS(ON)}$ vs Temperature" curve of the power MOSFET.

Layout Consideration

In any high switching frequency converter, a correct layout is important to ensure proper operation of the regulator. With power devices switching at higher frequency, the resulting current transient will cause voltage spike across the interconnecting impedance and parasitic circuit elements. As an example, consider the turn-off transition of the PWM MOSFET. Before turn-off condition, the MOSFET is carrying the full load current. During turn-off, current stops flowing in the MOSFET and is freewheeling by the lower MOSFET and parasitic diode. Any parasitic inductance of the circuit generates a large voltage spike during the switching interval. In general, using short and wide printed circuit traces should minimize interconnecting impedances and the magnitude of voltage spike. And signal and power grounds are to be kept separating and finally combined to use the ground plane construction or single point grounding. The best tie-point between the signal ground and the power ground is at the negative side of the output capacitor on each channel, where there is less noise. Noisy traces beneath the IC are not recommended. Below is a checklist for your layout:

Application Information (Cont.)

Layout Consideration (Cont.)

- Keep the switching nodes (UGATE_x, LGATE_x, BOOT_x, and PHASE_x) away from sensitive small signal nodes (ILIM_x, and FB_x) since these nodes are fast moving signals. Therefore, keep traces to these nodes as short as possible and there should be no other weak signal traces in parallel with these traces on any layer.
- The signals going through these traces have both high dv/dt and high di/dt, with high peak charging and discharging current. The traces from the gate drivers to the MOSFETs (UGATE_x and LGATE_x) should be short and wide.
- Place the source of the high-side MOSFET and the drain of the low-side MOSFET as close as possible. Minimizing the impedance with wide layout plane between the two pads reduces the voltage bounce of the node.
- Decoupling capacitor, the resistor dividers, boot capacitors, and current-limit setting resistor should be close to their pins. (For example, place the decoupling ceramic capacitor near the drain of the high-side MOSFET as close as possible. The bulk capacitors are also placed near the drain).
- The input capacitor should be near the drain of the upper MOSFET; the high quality ceramic decoupling capacitor can be put close to the VCC and GND pins; the output capacitor should be near the loads. The input capacitor GND should be close to the output capacitor GND and the lower MOSFET GND.
- The drain of the MOSFETs (V_{IN} and PHASE_x nodes) should be a large plane for heat sinking. And PHASE_x pin traces are also the return path for UGATE_x. Connect these pins to the respective converter's upper MOSFET source.
- The controller used ripple mode control. Build the resistor divider close to the FB1 pin so that the high impedance trace is shorter when the output voltage is in adjustable mode. And the FB1 pin traces can't be close to the switching signal traces (UGATE_x, LGATE_x, BOOT_x, and PHASE_x).
- The PGND trace should be a separate trace, and independently go to the source of the low-side MOSFETs for current-limit accuracy.

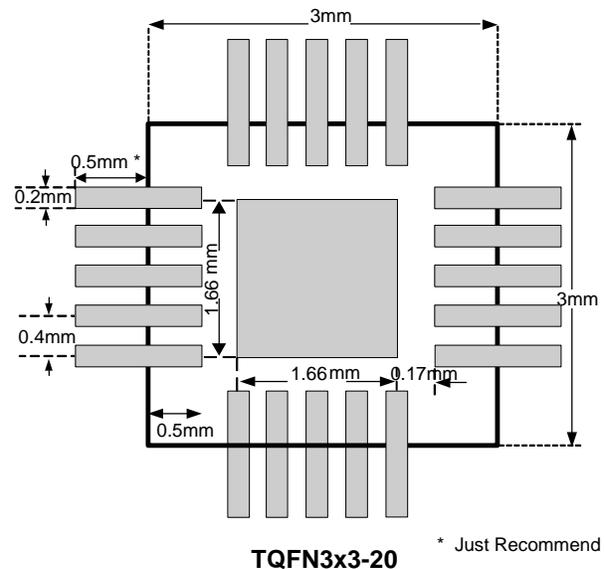

Package Information

TQFN3x3-20

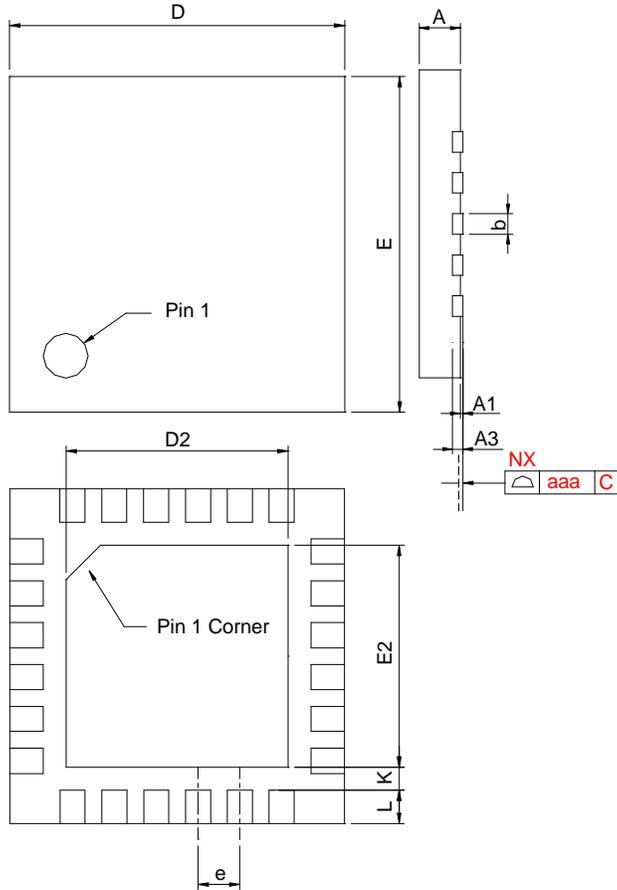

FORMER SYSTEM	TQFN3x3-20			
	MILLIMETERS		INCHES	
	MIN.	MAX.	MIN.	MAX.
A	0.70	0.80	0.028	0.031
A1	0.00	0.05	0.000	0.002
A3	0.20 REF		0.008 REF	
b	0.15	0.25	0.006	0.010
D	2.90	3.10	0.114	0.122
D2	1.50	1.80	0.059	0.071
E	2.90	3.10	0.114	0.122
E2	1.50	1.80	0.059	0.071
e	0.40 BSC		0.016 BSC	
L	0.30	0.50	0.012	0.020
K	0.20		0.008	
aaa	0.08		0.003	

Note : 1. Followed from JEDEC MO-220 WEEE

Carrier Tape & Reel Dimensions

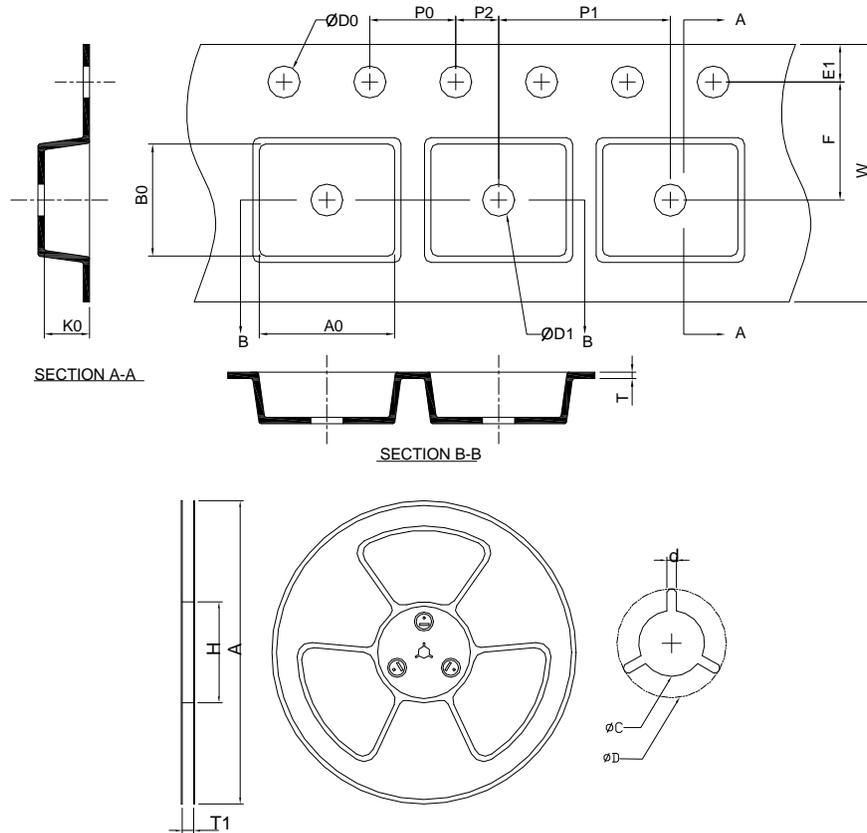

Application	A	H	T1	C	d	D	W	E1	F
TQFN3x3-20	330 ±0.00	50 MIN.	12.4+2.00 -0.00	13.0+0.50 -0.20	1.5 MIN.	20.2 MIN.	12.0 ±0.30	1.75 ±0.10	5.5 ±0.05
	P0	P1	P2	D0	D1	T	A0	B0	K0
	4.0 ±0.10	8.0 ±0.10	2.0 ±0.05	1.5+0.10 -0.00	1.5 MIN.	0.6+0.00 -0.40	3.30 ±0.20	3.30 ±0.20	1.30 ±0.20

(mm)

Devices Per Unit

Package Type	Unit	Quantity
TQFN3x3-20	Tape & Reel	3000

Taping Direction Information

TQFN3x3-20

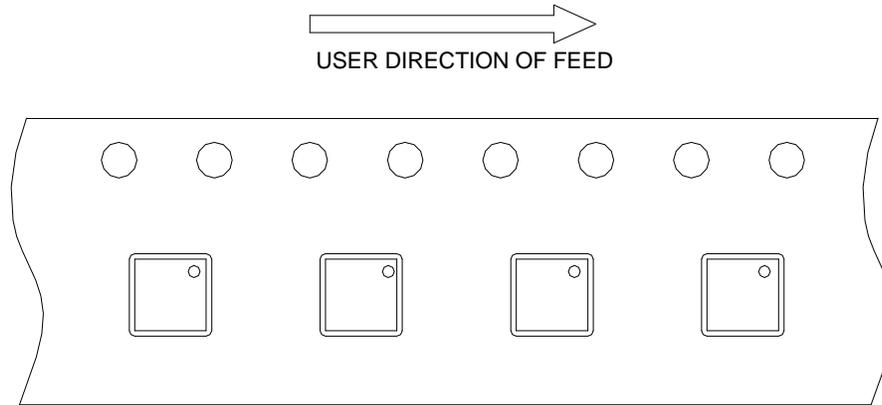

Classification Profile

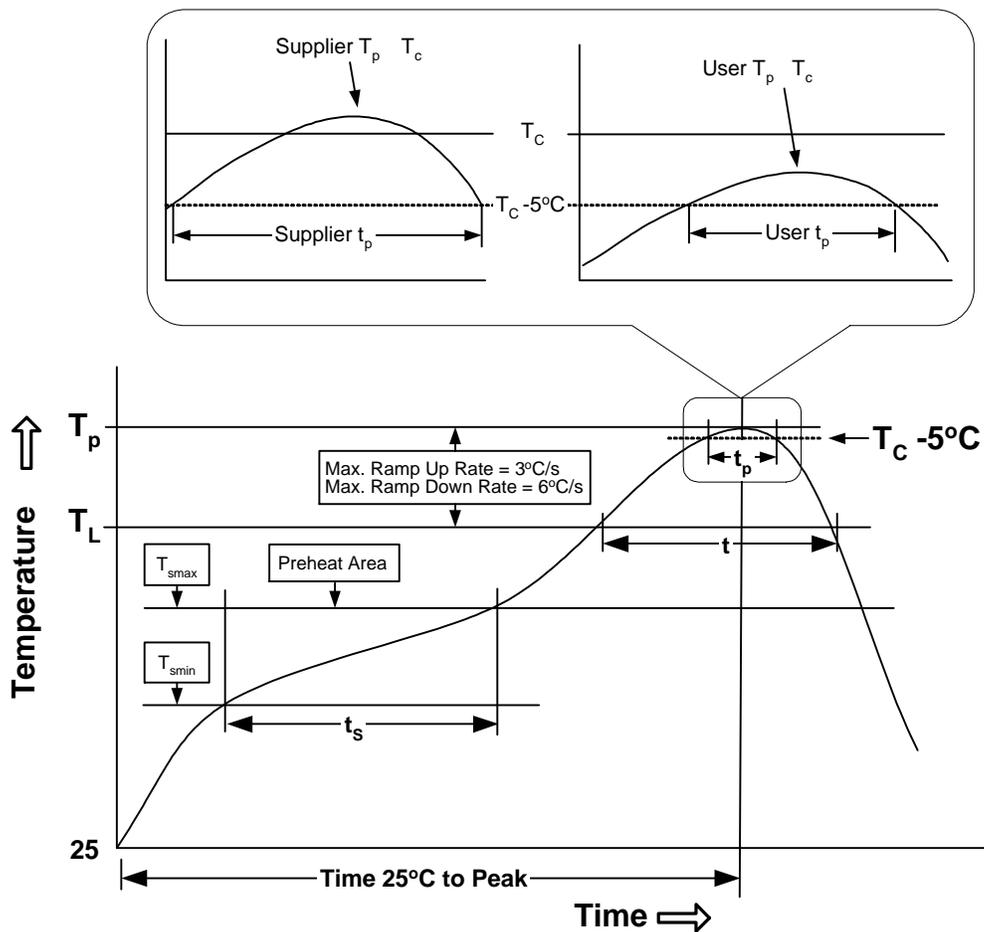

Classification Reflow Profiles

Profile Feature	Sn-Pb Eutectic Assembly	Pb-Free Assembly
Preheat & Soak		
Temperature min (T_{smin})	100 °C	150 °C
Temperature max (T_{smax})	150 °C	200 °C
Time (T_{smin} to T_{smax}) (t_s)	60-120 seconds	60-120 seconds
Average ramp-up rate (T_{smax} to T_p)	3 °C/second max.	3 °C/second max.
Liquidous temperature (T_L)	183 °C	217 °C
Time at liquidous (t_L)	60-150 seconds	60-150 seconds
Peak package body Temperature (T_p)*	See Classification Temp in table 1	See Classification Temp in table 2
Time (t_p)** within 5°C of the specified classification temperature (T_c)	20** seconds	30** seconds
Average ramp-down rate (T_p to T_{smax})	6 °C/second max.	6 °C/second max.
Time 25°C to peak temperature	6 minutes max.	8 minutes max.
* Tolerance for peak profile Temperature (T_p) is defined as a supplier minimum and a user maximum.		
** Tolerance for time at peak profile temperature (t_p) is defined as a supplier minimum and a user maximum.		

Classification Reflow Profiles (Cont.)

Table 1. SnPb Eutectic Process – Classification Temperatures (T_c)

Package Thickness	Volume mm ³ <350	Volume mm ³ ≥350
<2.5 mm	235 °C	220 °C
≥2.5 mm	220 °C	220 °C

Table 2. Pb-free Process – Classification Temperatures (T_c)

Package Thickness	Volume mm ³ <350	Volume mm ³ 350-2000	Volume mm ³ >2000
<1.6 mm	260 °C	260 °C	260 °C
1.6 mm – 2.5 mm	260 °C	250 °C	245 °C
≥2.5 mm	250 °C	245 °C	245 °C

Reliability Test Program

Test item	Method	Description
SOLDERABILITY	JESD-22, B102	5 Sec, 245°C
HOLT	JESD-22, A108	1000 Hrs, Bias @ $T_j=125^\circ\text{C}$
PCT	JESD-22, A102	168 Hrs, 100%RH, 2atm, 121°C
TCT	JESD-22, A104	500 Cycles, -65°C~150°C
HBM	MIL-STD-883-3015.7	VHBM 2KV
MM	JESD-22, A115	VMM 200V
Latch-Up	JESD 78	10ms, 1_{tr} 100mA

Customer Service

Anpec Electronics Corp.

Head Office :

No.6, Dusing 1st Road, SBIP,
Hsin-Chu, Taiwan, R.O.C.
Tel : 886-3-5642000
Fax : 886-3-5642050

Taipei Branch :

2F, No. 11, Lane 218, Sec 2 Jhongsing Rd.,
Sindian City, Taipei County 23146, Taiwan
Tel : 886-2-2910-3838
Fax : 886-2-2917-3838