



15N10

Power MOSFET

14.7A, 100V (D-S) N-CHANNEL POWER MOSFET

DESCRIPTION

The UTC **15N10** is an N-Channel enhancement MOSFET, it uses UTC's advanced technology to provide customers with a minimum on-state resistance, high switching speed and low gate charge.

The UTC **15N10** is suitable for high efficiency switching DC/DC converter, LCD display inverter and load switch.

FEATURES

- * $R_{DS(ON)}=0.08\Omega$ @ $V_{GS}=10V, I_D=8A$
- * Low gate charge (Typ=24nC)
- * Low C_{RSS} (Typ=23pF)
- * High switching speed

SYMBOL

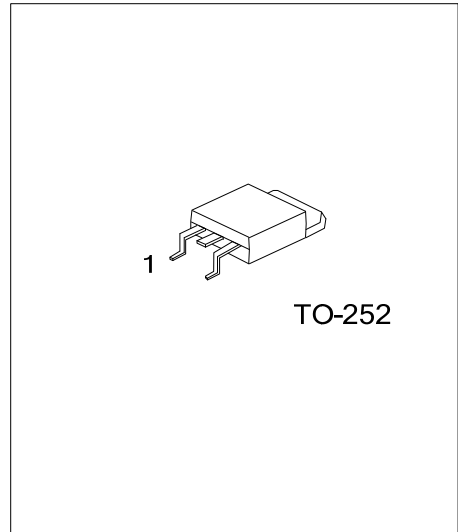
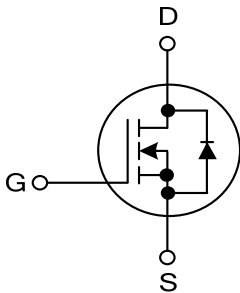

ORDERING INFORMATION

Ordering Number		Package	Pin Assignment			Packing
Lead Free	Halogen Free		1	2	3	
15N10L-TN3-T	15N10G-TN3-T	TO-252	G	D	S	Tube
15N10L-TN3-R	15N10G-TN3-R	TO-252	G	D	S	Tape Reel

Note: Pin Assignment: G: Gate D: Drain S: Source

<p>15N10L-TN3-R</p> <p>(1) Packing Type</p> <p>(2) Package Type</p> <p>(3) Lead Free</p>	<p>(1) T: Tube, R: Tape Reel</p> <p>(2) TN3: TO-252</p> <p>(3) L: Lead Free, G: Halogen Free</p>
--	--

■ ABSOLUTE MAXIMUM RATINGS ($T_A=25^\circ\text{C}$, unless otherwise noted)

PARAMETER		SYMBOL	RATINGS	UNIT	
Drain-Source Voltage		V_{DSS}	100	V	
Gate-Source Voltage		V_{GSS}	± 20	V	
Drain Current	Continuous	I_D	$T_C=25^\circ\text{C}, T_J=150^\circ\text{C}$	14.7	A
			$T_C=70^\circ\text{C}, T_J=150^\circ\text{C}$	13.6	A
Pulsed		I_{DM}	59	A	
Power Dissipation		P_D	$T_C=25^\circ\text{C}$	34.7	W
			$T_C=70^\circ\text{C}$	22.2	W
Operating Junction Temperature		T_J	-55~+150	$^\circ\text{C}$	

Note: Absolute maximum ratings are those values beyond which the device could be permanently damaged. Absolute maximum ratings are stress ratings only and functional device operation is not implied.

■ THERMAL CHARACTERISTICS ($T_A=25^\circ\text{C}$, unless otherwise noted)

PARAMETER	SYMBOL	RATINGS	UNIT
Junction to Case (Note)	θ_{JC}	3.6	$^\circ\text{C/W}$

Note: The device mounted on 1in² FR4 board with 2 oz copper.

■ ELECTRICAL CHARACTERISTICS ($T_A=25^\circ\text{C}$, unless otherwise specified)

PARAMETER	SYMBOL	TEST CONDITIONS	MIN	TYP	MAX	UNIT
OFF CHARACTERISTICS						
Drain-Source Breakdown Voltage	BV_{DSS}	$I_D=250\mu\text{A}, V_{GS}=0\text{V}$	100			V
Drain-Source Leakage Current	I_{DSS}	$V_{DS}=80\text{V}, V_{GS}=0\text{V}$			1	μA
Gate-Source Leakage Current	I_{GSS}	$V_{GS}=+20\text{V}, V_{DS}=0\text{V}$			+100	nA
		$V_{GS}=-20\text{V}, V_{DS}=0\text{V}$			-100	nA
ON CHARACTERISTICS						
Gate Threshold Voltage	$V_{GS(TH)}$	$V_{DS}=V_{GS}, I_D=250\mu\text{A}$	1		3	V
Drain-Source On-State Resistance (Note)	$R_{DS(ON)}$	$V_{GS}=10\text{V}, I_D=8\text{A}$		80	100	m Ω
DYNAMIC PARAMETERS						
Input Capacitance	C_{ISS}	$V_{GS}=0\text{V}, V_{DS}=15\text{V}, f=1\text{MHz}$		890		pF
Output Capacitance	C_{OSS}			58		pF
Reverse Transfer Capacitance	C_{RSS}			23		pF
SWITCHING PARAMETERS						
Total Gate Charge	Q_G	$V_{GS}=10\text{V}, V_{DS}=80\text{V}, I_D=10\text{A}$		24		nC
Total Gate Charge	Q_G	$V_{GS}=4.5\text{V}, V_{DS}=80\text{V}, I_D=10\text{A}$		13		nC
Gate to Source Charge	Q_{GS}			4.6		nC
Gate to Drain Charge	Q_{GD}			7.6		nC
Gate-Resistance	R_G	$V_{DS}=0\text{V}, V_{GS}=0\text{V}, f=1\text{MHz}$		0.9		Ω
Turn-ON Delay Time	$t_{D(ON)}$	$V_{DS}=50\text{V}, R_L=5\Omega, V_{GEN}=10\text{V}, R_G=1\Omega$		14		ns
Rise Time	t_R			33		ns
Turn-OFF Delay Time	$t_{D(OFF)}$			39		ns
Fall-Time	t_F			5		ns
SOURCE- DRAIN DIODE RATINGS AND CHARACTERISTICS						
Drain-Source Diode Forward Voltage	V_{SD}	$I_S=8\text{A}, V_{GS}=0\text{V}$		0.9	1.2	V

Note: Pulse test: pulse width $\leq 300\mu\text{s}$, duty cycle $\leq 2\%$, Guaranteed by design, not subject to production testing.

■ TEST CIRCUITS AND WAVEFORMS

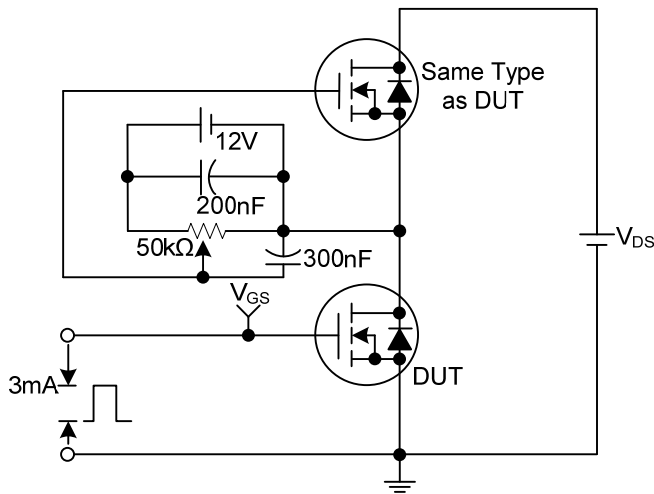

Gate Charge Test Circuit

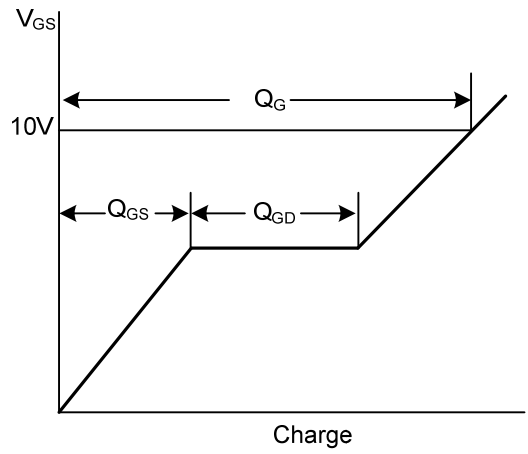

Gate Charge Waveforms

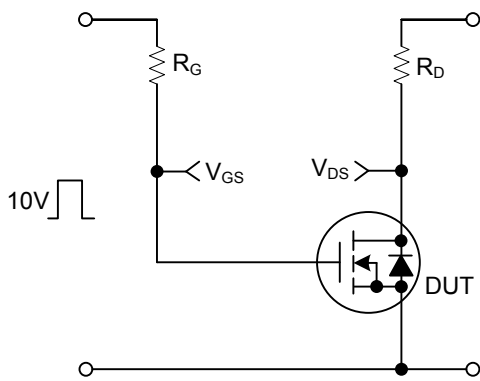

Resistive Switching Test Circuit

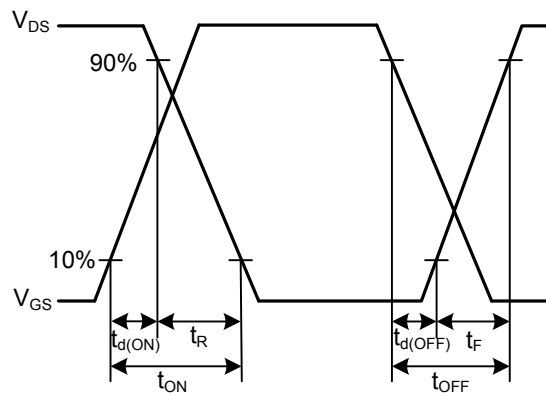

Resistive Switching Waveforms

■ TEST CIRCUITS AND WAVEFORMS

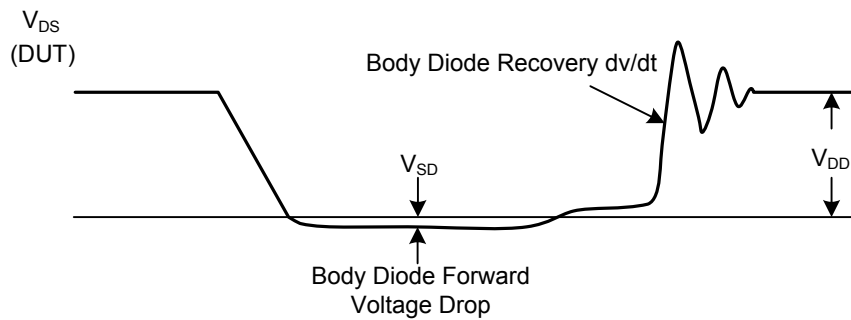
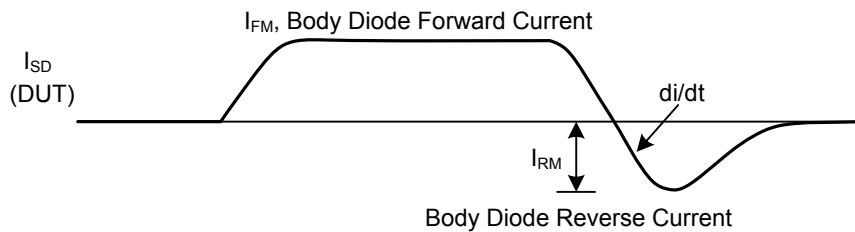
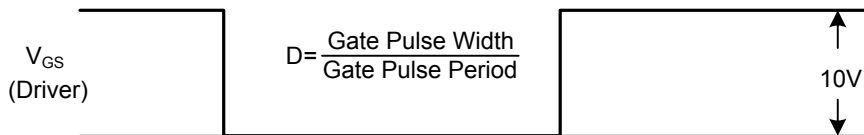
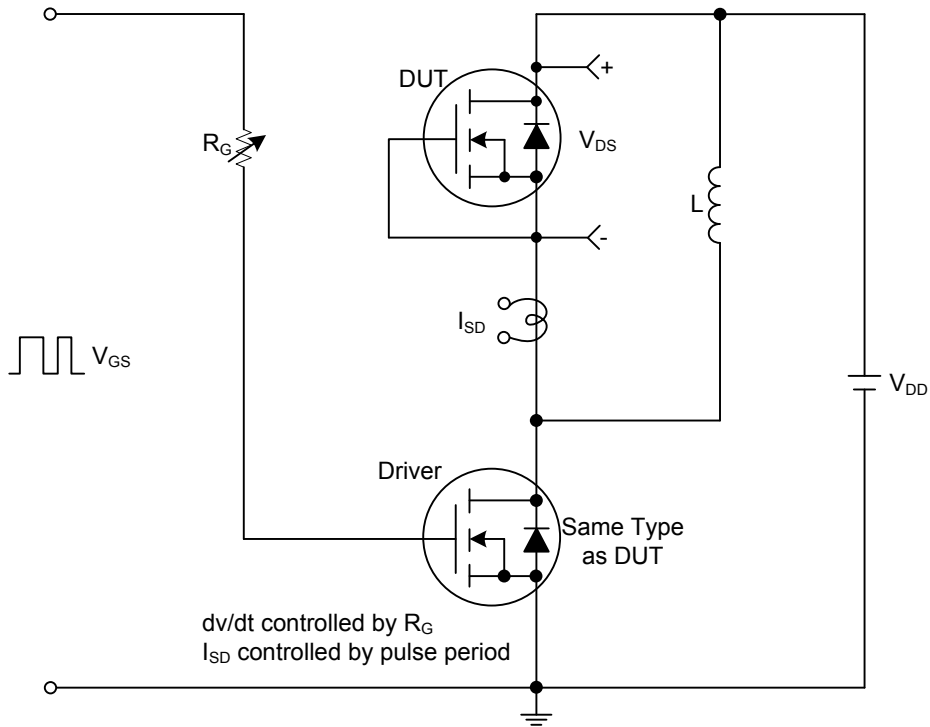

Peak Diode Recovery dv/dt Test Circuit and Waveforms

TYPICAL CHARACTERISTICS

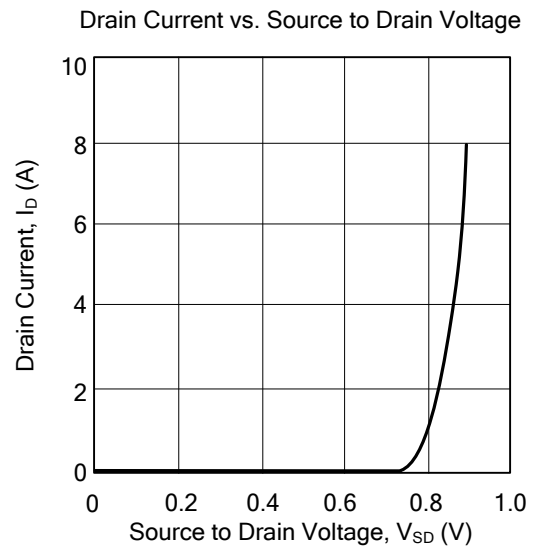
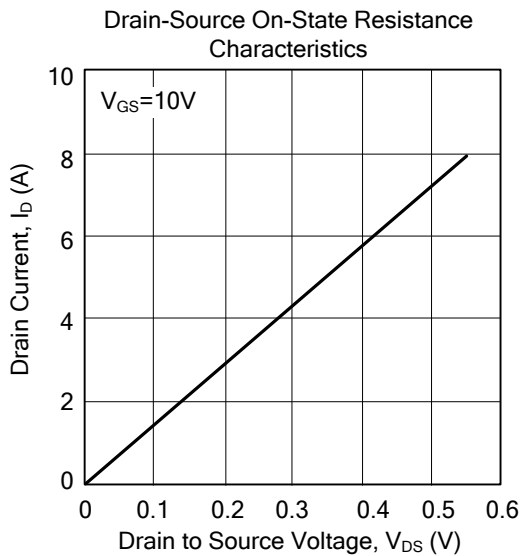
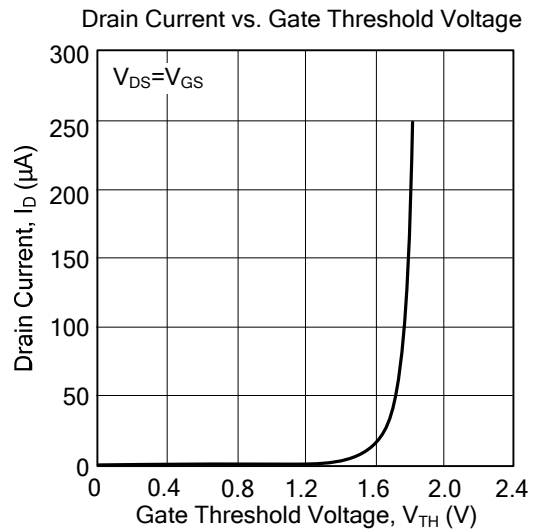
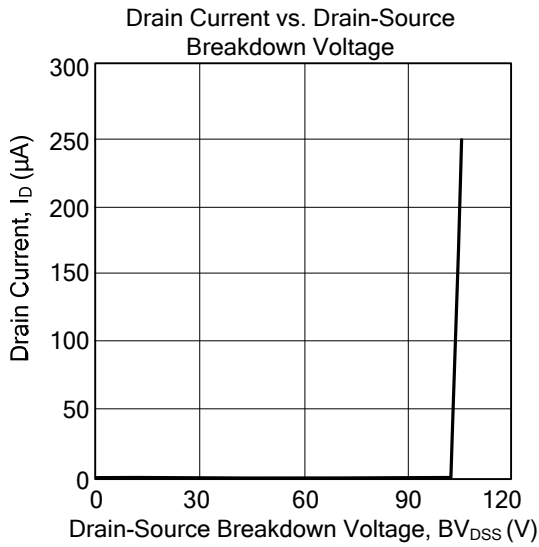

UTC assumes no responsibility for equipment failures that result from using products at values that exceed, even momentarily, rated values (such as maximum ratings, operating condition ranges, or other parameters) listed in products specifications of any and all UTC products described or contained herein. UTC products are not designed for use in life support appliances, devices or systems where malfunction of these products can be reasonably expected to result in personal injury. Reproduction in whole or in part is prohibited without the prior written consent of the copyright owner. The information presented in this document does not form part of any quotation or contract, is believed to be accurate and reliable and may be changed without notice.