

## 3V LOGIC OUTPUT TEMPERATURE SENSOR WITH PROGRAMMABLE HYSTERESIS

### FEATURES

- User Programmable Hysteresis and Temperature Set Point
- Easily Programs with Two External Resistors
- Wide Temperature Detection Range
  - TC07CxA ..... 0°C to +70°C
  - TC07ExA ..... -40°C to +85°C
  - TC07VxA ..... -40°C to +125°C
- Small 8-Pin MSOP and 8-Pin SOIC Packages
- Cost Effective

### APPLICATIONS

- Power Supply Over-Temperature Detection
- Consumer Equipment
- Temperature Regulators
- Computer Equipment

### ORDERING INFORMATION

Part No.	Package	Temp. Range
TC07COA	8-Pin SOIC	0°C to +70°C
TC07CUA	8-Pin MSOP	0°C to +70°C
TC07EOA	8-Pin SOIC	-40°C to +85°C
TC07EUA	8-Pin MSOP	-40°C to +85°C
TC07VOA	8-Pin SOIC	-40°C to +125°C
TC07VUA	8-Pin MSOP	-40°C to +125°C

### FUNCTIONAL BLOCK DIAGRAM

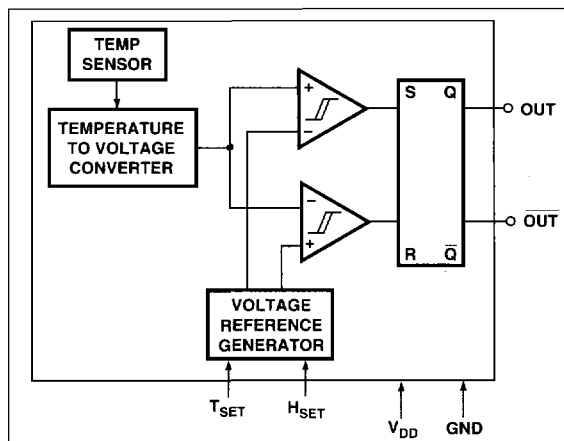

### GENERAL DESCRIPTION

The TC07 is a programmable, logic output temperature detector that operates from power supply levels as low as 2.7V. Programming is accomplished with external resistors connected from the temperature setpoint input ( $T_{SET}$ ) and the hysteresis control input ( $H_{SET}$ ) to  $V_{DD}$ .

Complimentary outputs ( $OUT$  and  $\overline{OUT}$ ) are driven active when temperature exceeds the temperature threshold programmed by the resistor on  $T_{SET}$ . The states of these outputs are maintained (latched) until temperature falls below threshold programmed by the resistor on  $H_{SET}$ .

The TC07 is useful over a maximum temperature range of -40°C to +125°C (TC07VxA). It features low (<130 $\mu$ A) supply current and small physical size 8-pin MSOP and 8-pin SOIC packages, making it suitable for a wide variety of applications.

### PIN CONFIGURATION

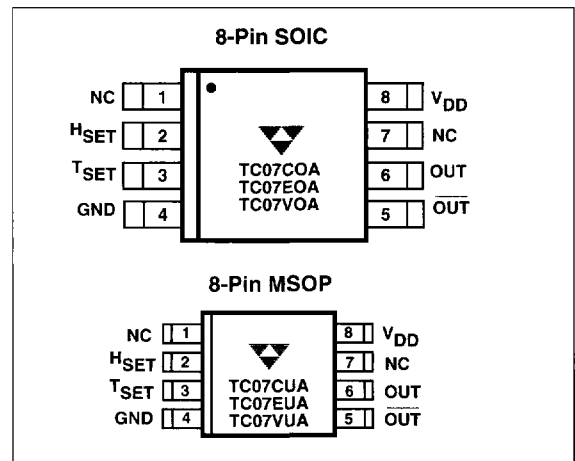

# 3V LOGIC OUTPUT TEMPERATURE SENSOR WITH PROGRAMMABLE HYSTERESIS

## TC07

### ABSOLUTE MAXIMUM RATINGS\*

Supply Voltage .....	7V
Input Voltage Any Input .....	(GND - 0.3V) to (V <sub>DD</sub> + 0.3V)
Operating Temperature .....	- 40°C to +125°C
Maximum Chip Temperature .....	+150°C
Storage Temperature .....	- 65°C to +150°C
Lead Temperature (Soldering, 10 sec) .....	+300°C

\* Stresses above those listed under "Absolute Maximum Ratings" may cause permanent damage to the device. These are stress ratings only and functional operation of the device at these or any other conditions above those indicated in the operation sections of the specifications is not implied. Exposure to absolute maximum rating conditions for extended periods may affect device reliability.

### ELECTRICAL CHARACTERISTICS: T<sub>A</sub> = Over Operational Temperature Range, unless otherwise specified.

Symbol	Parameter	Conditions	Min	Typ	Max	Unit
V <sub>DD</sub>	Supply Voltage Range		2.7	—	5.5	V
I <sub>DD</sub>	Supply Current	2.7V < V <sub>CC</sub> < 5.5V	—	130	300	μA
V <sub>OH</sub>	Output Voltage (High)	I <sub>OUT</sub> = 500μA	0.8 x V <sub>DD</sub>	—	—	V
V <sub>OL</sub>	Output Voltage (Low)	I <sub>OUT</sub> = 1mA	—	—	0.25 x V <sub>DD</sub>	V
H	Minimum Hysteresis	H <sub>SET</sub> < T <sub>SET</sub>	- 5	—	—	°C
T <sub>SET</sub>	Absolute Accuracy	T = Programmed Temperature	T - 3	T ± 1	T + 3	°C
H <sub>SET</sub>	Absolute Accuracy	T = Programmed Temperature	T - 5	T ± 1	T + 5	°C

### DETAILED DESCRIPTION

The TC07 programs with resistors connected from the T<sub>SET</sub> and H<sub>SET</sub> inputs to V<sub>DD</sub>. Output pins OUT and  $\overline{\text{OUT}}$  are driven active when temperature exceeds the setting determined by the programming resistor on T<sub>SET</sub>. The outputs are maintained (latched) in their active states until temperature drops below the setting determined by the programming resistor on H<sub>SET</sub> (Figure 1).

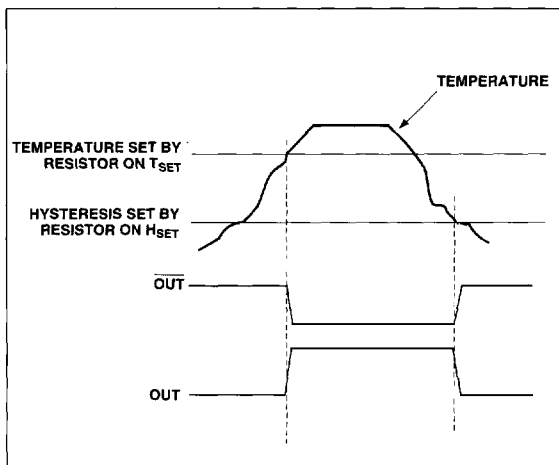

Figure 1. TC07 Output Waveforms

### APPLICATIONS

#### Trip Point Programming

The resistor values required to achieve the desired trip-point temperatures on T<sub>SET</sub> and H<sub>SET</sub> are calculated using the formula below:

$$R_{\text{TRIP}} = 0.6 \times T^{2.13}$$

Where:

R<sub>TRIP</sub> = Programming resistor value in Ohms  
 T = Desired trip point temperature in degrees Kelvin.

For example, to program the TC07 outputs to go active at 50°C and inactive at 30°C, the T<sub>SET</sub> and H<sub>SET</sub> programming resistors are calculated as follows:

$$T_{\text{SET}} = 0.6 \times ((50 + 273.15)^{2.13}) = 132.8\text{k}\Omega$$

$$H_{\text{SET}} = 0.6 \times ((30 + 273.15)^{2.13}) = 115.9\text{k}\Omega$$

Resistance values for T<sub>SET</sub> and H<sub>SET</sub> can be approximated using Figure 2. Care must be taken to ensure the H<sub>SET</sub> programming resistor is a smaller value than the T<sub>SET</sub> programming resistor. The temperature programmed on H<sub>SET</sub> must be at least 5°C lower than the temperature value programmed by T<sub>SET</sub>. That is: H<sub>SET</sub> ≤ T<sub>SET</sub> - 5°C.

# 3V LOGIC OUTPUT TEMPERATURE SENSOR WITH PROGRAMMABLE HYSTERESIS

TC07

2

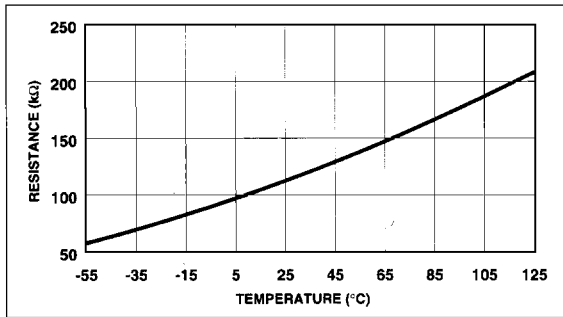

Figure 2. Programming Resistor Values vs. Temperature

## Cooling and Heating Applications

The TC07 can be used to control a DC fan as shown in Figure 3. The fan turns on when the sensed temperature rises above  $T_{SET}$  and remains on until the temperature falls below  $H_{SET}$ . The amount of "over-cooling" performed by the fan is dependent on the programmed hysteresis.

Figure 4 shows the TC07 acting as a heater thermostat. Circuit operation is identical to that of the cooling fan application.

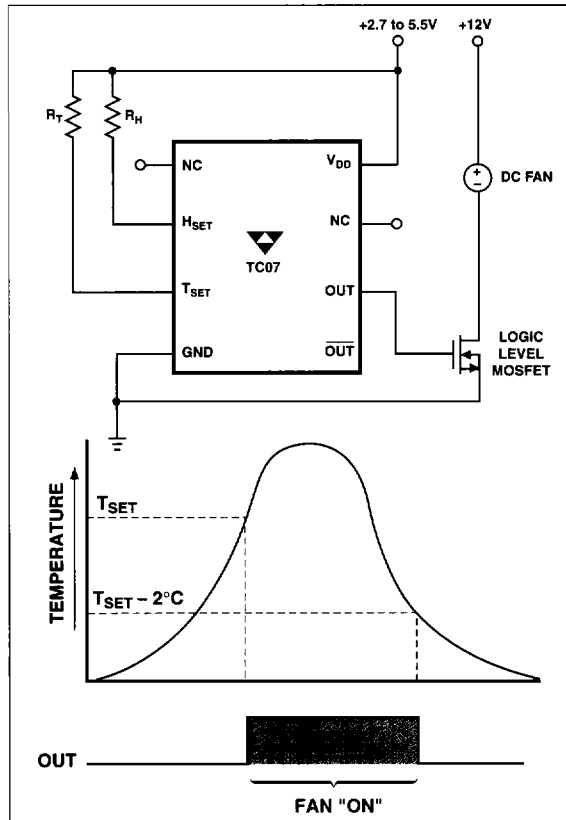

Figure 3. TC07 as a Fan Controller

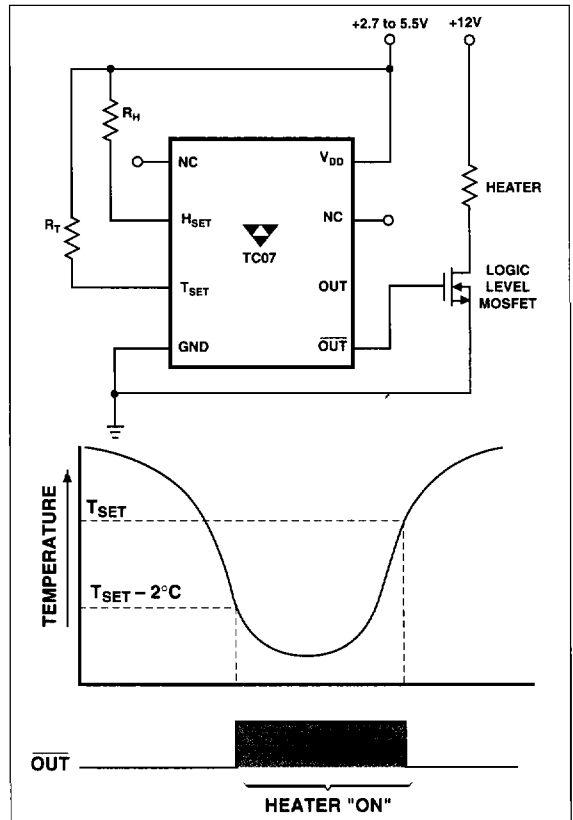

Figure 4. TC07 as a Heater Thermostat