



M95640, M95320 M95160, M95080

64/32/16/8 Kbit Serial SPI Bus EEPROM With High Speed Clock

PRELIMINARY DATA

- SPI Bus Compatible Serial Interface
- Supports Positive Clock SPI Modes
- 5 MHz Clock Rate (maximum)
- Single Supply Voltage:
 - 4.5V to 5.5V for M95xxx
 - 2.7V to 3.6V for M95xxx-V
 - 2.5V to 5.5V for M95xxx-W
 - 1.8V to 3.6V for M95xxx-S
- Status Register
- Hardware and Software Protection of the Status Register
- BYTE and PAGE WRITE (up to 32 Bytes)
- Self-Timed Programming Cycle
- Adjustable Size Read-Only EEPROM Area
- Enhanced ESD Protection
- More than 100,000 Erase/Write Cycles
- More than 40 Year Data Retention

DESCRIPTION

These SPI-compatible electrically erasable programmable memory (EEPROM) devices are organized as 8K x 8 bits and 4K x 8 bits (M95640, M95320) and 2K x 8 bits and 1K x 8 bits (M95160, M95080), and operate down to 2.5 V (for the -W

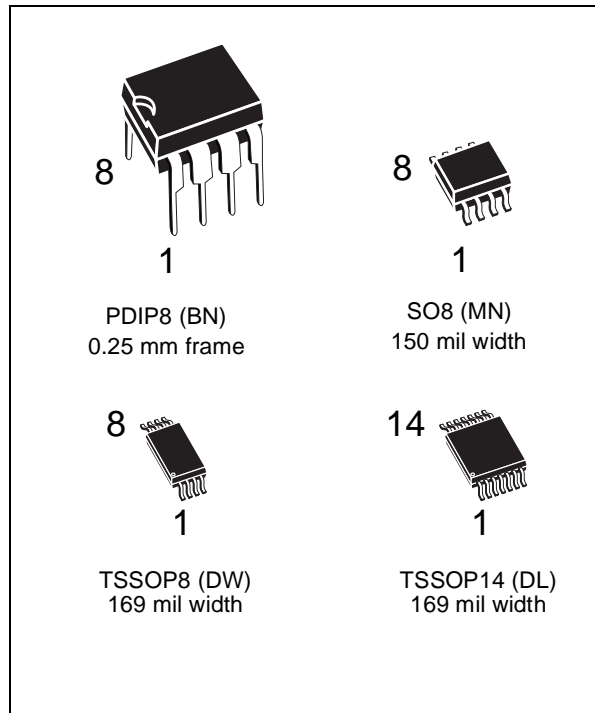
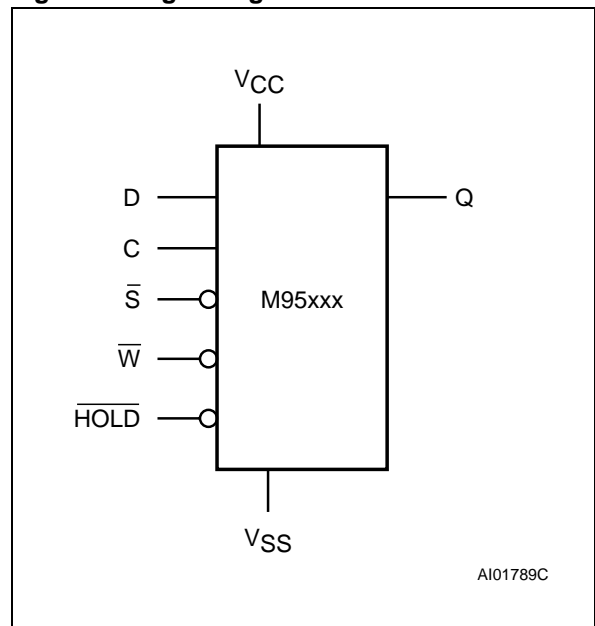

Table 1. Signal Names

C	Serial Clock
D	Serial Data Input
Q	Serial Data Output
\bar{S}	Chip Select
\bar{W}	Write Protect
\overline{HOLD}	Hold
V _{CC}	Supply Voltage
V _{SS}	Ground

Figure 1. Logic Diagram



M95640, M95320, M95160, M95080

Figure 2A. DIP Connections

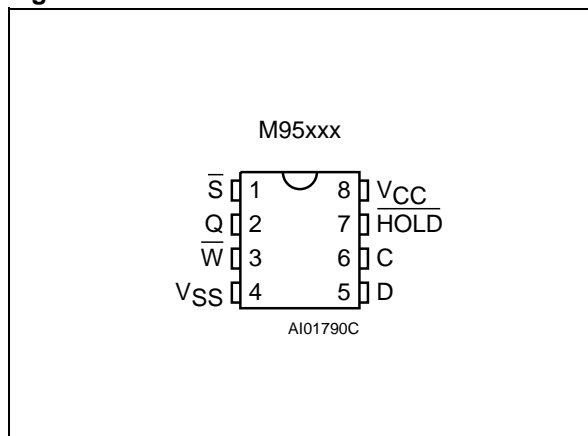
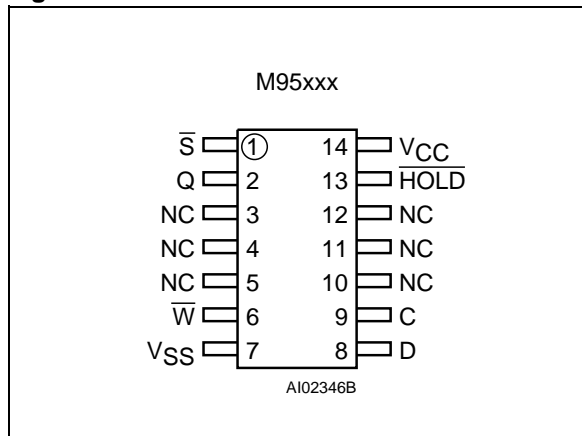
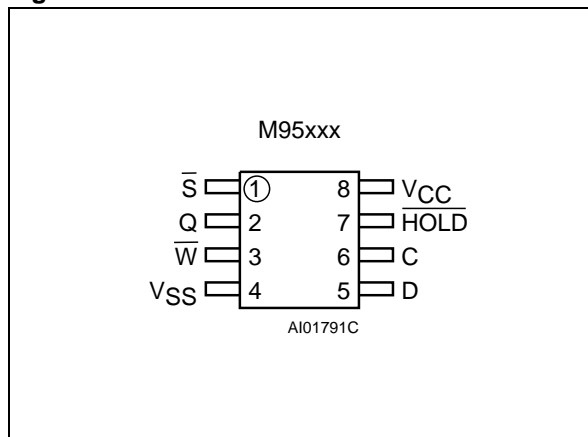

Figure 2C. TSSOP14 Connections



Note: 1. NC = Not Connected

Figure 2B. SO8 and TSSOP8 Connections



version of each device), and down to 1.8 V (for the -S version of each device).

The M95640, M95320 and M95160, M95080 are available in Plastic Dual-in-Line, Plastic Small Outline and Thin Shrink Small Outline packages.

Each memory device is accessed by a simple serial interface that is SPI bus compatible. The bus signals are C, D and Q, as shown in Table 1 and Figure 3.

The device is selected when the chip select input (\bar{S}) is held low. Communications with the chip can be interrupted using the hold input (HOLD).

Table 2. Absolute Maximum Ratings ¹

Symbol	Parameter	Value	Unit
T_A	Ambient Operating Temperature	-40 to 125	°C
T_{STG}	Storage Temperature	-65 to 150	°C
T_{LEAD}	Lead Temperature during Soldering	PDIP8: 10 seconds SO8: 20 seconds (max) ² TSSOP14: 20 seconds (max) ²	°C
V_O	Output Voltage	-0.3 to $V_{CC}+0.6$	V
V_I	Input Voltage	-0.3 to 6.5	V
V_{CC}	Supply Voltage	-0.3 to 6.5	V
V_{ESD}	Electrostatic Discharge Voltage (Human Body model) ³	4000	V

Note: 1. Except for the rating "Operating Temperature Range", stresses above those listed in the Table "Absolute Maximum Ratings" may cause permanent damage to the device. These are stress ratings only, and operation of the device at these or any other conditions above those indicated in the Operating sections of this specification is not implied. Exposure to Absolute Maximum Rating conditions for extended periods may affect device reliability. Refer also to the ST SURE Program and other relevant quality documents.

2. IPC/JEDEC J-STD-020A

3. JEDEC Std JESD22-A114A (C1=100 pF, R1=1500 Ω, R2=500 Ω)

Figure 3. Bus Master and Memory Devices on the SPI Bus

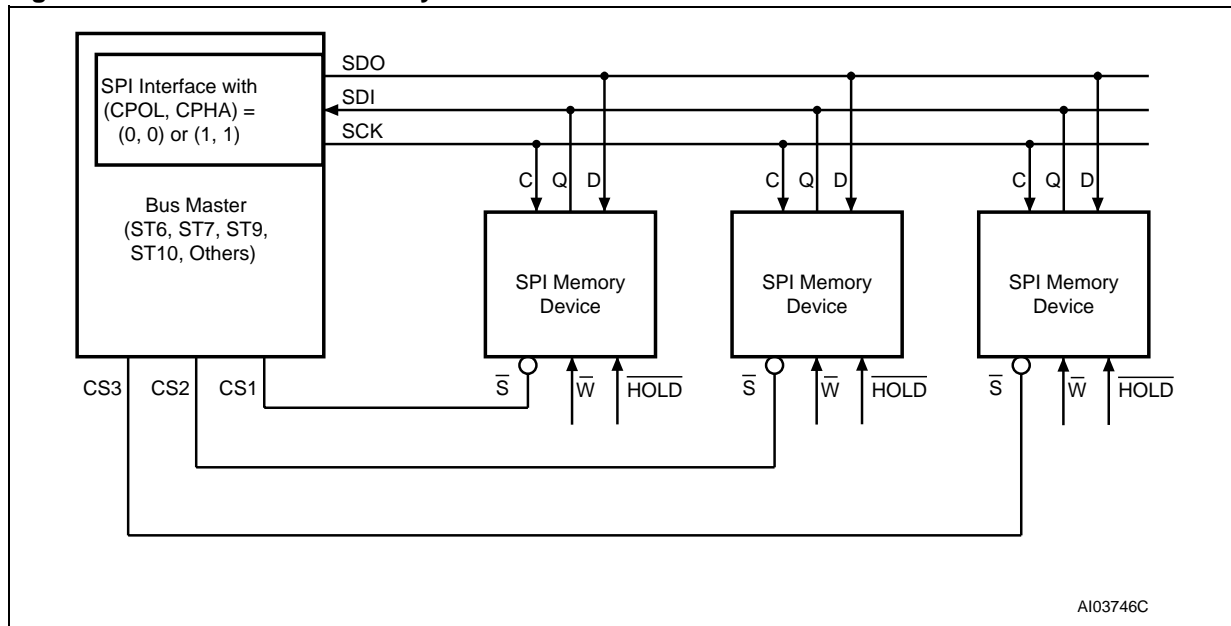

Note: 1. The Write Protect (\overline{W}) and Hold (\overline{HOLD}) signals should be driven, High or Low as appropriate.

SIGNAL DESCRIPTION

Serial Output (Q)

The output pin is used to transfer data serially out of the Memory. Data is shifted out on the falling edge of the serial clock.

Serial Input (D)

The input pin is used to transfer data serially into the device. Instructions, addresses, and the data to be written, are each received this way. Input is latched on the rising edge of the serial clock.

Serial Clock (C)

The serial clock provides the timing for the serial interface (as shown in Figure 4). Instructions, addresses, or data are latched, from the input pin, on the rising edge of the clock input. The output data on the Q pin changes state after the falling edge of the clock input.

Chip Select (\overline{S})

When \overline{S} is high, the memory device is deselected, and the Q output pin is held in its high impedance state. Unless an internal write operation is underway, the memory device is placed in its stand-by power mode.

After power-on, a high-to-low transition on \overline{S} is required prior to the start of any operation.

Write Protect (\overline{W})

The protection features of the memory device are summarized in Table 3.

The hardware write protection, controlled by the \overline{W} pin, restricts write access to the Status Register

(though not to the WIP and WEL bits, which are set or reset by the device internal logic).

Bit 7 of the status register (as shown in Table 5) is the Status Register Write Disable bit (SRWD). When this is set to 0 (its initial delivery state) it is possible to write to the status register if the WEL bit (Write Enable Latch) has been set by the WREN instruction (irrespective of the level being applied to the \overline{W} input).

When bit 7 (SRWD) of the status register is set to 1, the ability to write to the status register depends on the logic level being presented at pin \overline{W} :

- If \overline{W} pin is high, it is possible to write to the status register, after having set the WEL bit using the WREN instruction (Write Enable Latch).
- If \overline{W} pin is low, any attempt to modify the status register is ignored by the device, even if the WEL bit has been set. As a consequence, all the data bytes in the EEPROM area, protected by the BPn bits of the status register, are also hardware protected against data corruption, and appear as a Read Only EEPROM area for the microcontroller. This mode is called the Hardware Protected Mode (HPM).

It is possible to enter the Hardware Protected Mode (HPM) either by setting the SRWD bit after pulling low the \overline{W} pin, or by pulling low the \overline{W} pin after setting the SRWD bit.

The only way to abort the Hardware Protected Mode, once entered, is to pull high the \overline{W} pin.

Figure 4. Data and Clock Timing

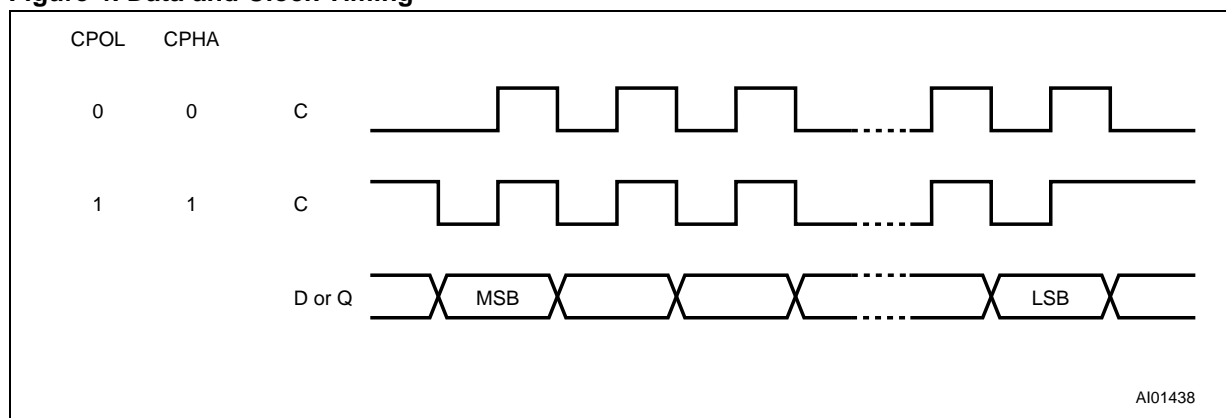

If \bar{W} pin is permanently tied to the high level, the Hardware Protected Mode is never activated, and the memory device only allows the user to protect a part of the memory, using the BPn bits of the status register, in the Software Protected Mode (SPM).

Hold (HOLD)

The $\overline{\text{HOLD}}$ pin is used to pause the serial communications between the SPI memory and controller, without losing bits that have already been decoded in the serial sequence. For a hold condition to occur, the memory device must already have been selected ($\bar{S} = 0$). The hold condition starts when the $\overline{\text{HOLD}}$ pin is held low while the clock pin (C) is also low (as shown in Figure 14).

During the hold condition, the Q output pin is held in its high impedance state, and the levels on the input pins (D and C) are ignored by the memory device.

It is possible to deselect the device when it is still in the hold state, thereby resetting whatever transfer had been in progress. The memory remains in the hold state as long as the $\overline{\text{HOLD}}$ pin

is low. To restart communication with the device, it is necessary both to remove the hold condition (by taking $\overline{\text{HOLD}}$ high) and to select the memory (by taking \bar{S} low).

OPERATIONS

All instructions, addresses and data are shifted serially in and out of the chip. The most significant bit is presented first, with the data input (D) sampled on the first rising edge of the clock (C) after the chip select (\bar{S}) goes low.

Every instruction starts with a single-byte code, as summarised in Table 4. This code is entered via the data input (D), and latched on the rising edge of the clock input (C). To enter an instruction code, the product must have been previously selected (\bar{S} held low). If an invalid instruction is sent (one not contained in Table 4), the chip automatically deselects itself.

Write Enable (WREN) and Write Disable (WRDI)

The write enable latch, inside the memory device, must be set prior to each WRITE and WRSR operation. The WREN instruction (write enable)

Table 3. Write Protection Control on the M95640, M95320, M95160, M95080

\bar{W}	SRWD Bit	Mode	Status Register	Data Bytes	
				Protected Area	Unprotected Area
0 or 1	0	Software Protected (SPM)	Writeable (if the WREN instruction has set the WEL bit)	The data write protection is defined by the BP1, BP0 bits. The BP1, BP0 bits can be modified by software (using WREN and WRSR)	Writeable (if the WREN instruction has set the WEL bit)
1	1				
0	1	Hardware Protected (HPM)	Hardware write protected	The data write protection is defined by the BP1, BP0 bits, which are, themselves, hardware write protected.	Writeable (if the WREN instruction has set the WEL bit)

Figure 5. Block Diagram

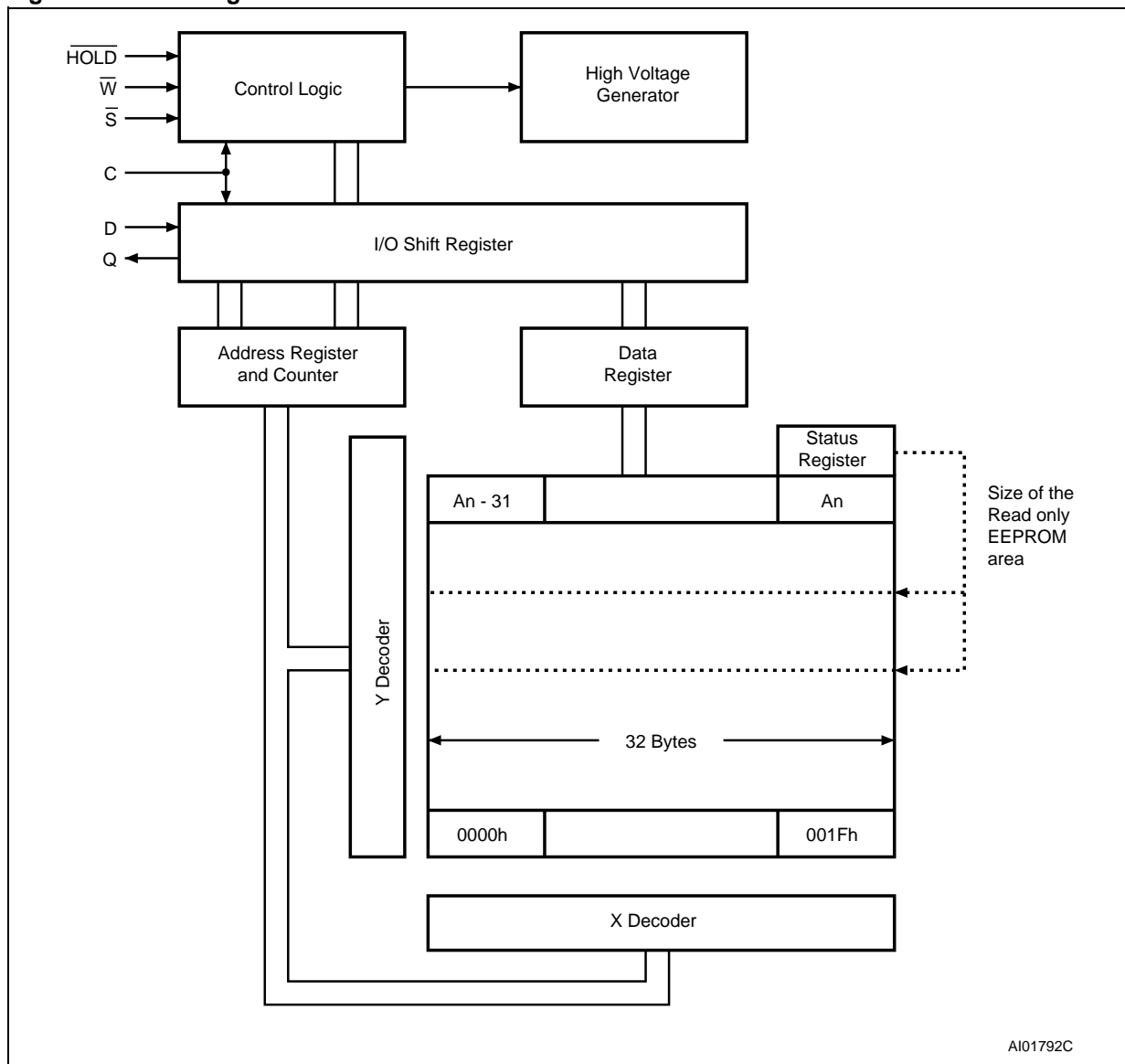

Note: 1. The cell A_n represents the byte at the highest address in the memory

sets this latch, and the WRDI instruction (write disable) resets it.

The latch becomes reset by any of the following events:

- Power on
- WRDI instruction completion
- WRSR instruction completion
- WRITE instruction completion.

As soon as the WREN or WRDI instruction is received, the memory device first executes the instruction, then enters a wait mode until the device is deselected.

Read Status Register (RDSR)

The RDSR instruction allows the status register to be read, and can be sent at any time, even during a Write operation. Indeed, when a Write is in progress, it is recommended that the value of the Write-In-Progress (WIP) bit be checked. The value in the WIP bit (whose position in the status register is shown in Table 5) can be continuously polled, before sending a new WRITE instruction. This can be performed in one of two ways:

- Repeated RDSR instructions (each one consisting of \bar{S} being taken low, C being clocked 8 times for the instruction and 8 times for the read operation, and \bar{S} being taken high)

Table 4. Instruction Set

Instruction	Description	Instruction Format
WREN	Set Write Enable Latch	0000 0110
WRDI	Reset Write Enable Latch	0000 0100
RDSR	Read Status Register	0000 0101
WRSR	Write Status Register	0000 0001
READ	Read Data from Memory Array	0000 0011
WRITE	Write Data to Memory Array	0000 0010

Table 5. Status Register Format

b7				b0			
SRWD	X	X	X	BP1	BP0	WEL	WIP

Note: 1. SRWD, BP0 and BP1 are Read and write bits.
 2. WEL and WIP are Read only bits.

- A single, prolonged RDSR instruction (consisting of \bar{S} being taken low, C being clocked 8 times for the instruction and kept running for repeated read operations), as shown in Figure 6.

The Write-In-Process (WIP) bit is read-only, and indicates whether the memory is busy with a Write operation. A '1' indicates that a write is in progress, and a '0' that no write is in progress.

The Write Enable Latch (WEL) bit indicates the status of the write enable latch. It, too, is read-only. Its value can only be changed by one of the events listed in the previous paragraph, or as a result of executing WREN or WRDI instruction. It cannot be changed using a WRSR instruction. A '1' indicates that the latch is set (the forthcoming Write instruction will be executed), and a '0' that it is

reset (and any forthcoming Write instructions will be ignored).

The Block Protect (BP0 and BP1) bits indicate the amount of the memory that is to be write-protected. These two bits are non-volatile. They are set using a WRSR instruction.

During a Write operation (whether it be to the memory area or to the status register), all bits of the status register remain valid, and can be read using the RDSR instruction. However, during a Write operation, the values of the non-volatile bits (SRWD, BP0, BP1) become frozen at a constant value. The updated value of these bits becomes available when a new RDSR instruction is executed, after completion of the write cycle. On the other hand, the two read-only bits (WEL, WIP) are dynamically updated during internal write cycles. Using this facility, it is possible to poll the WIP bit to detect the end of the internal write cycle.

Write Status Register (WRSR)

The format of the WRSR instruction is shown in Figure 7. After the instruction and the eight bits of the status register have been latched-in, the internal Write cycle is triggered by the rising edge of the \bar{S} line. This must occur after the falling edge of the 16th clock pulse, and before the rising edge of the 17th clock (as indicated in Figure 7), otherwise the internal write sequence is not performed.

The WRSR instruction is used for the following:

- to select the size of memory area that is to be write-protected
- to select between SPM (Software Protected Mode) and HPM (Hardware Protected Mode).

The size of the write-protection area applies equally in SPM and HPM. The BP1 and BP0 bits of the status register have the appropriate value (see Table 6) written into them after the contents

Figure 6. Read Status Register (RDSR) Sequence

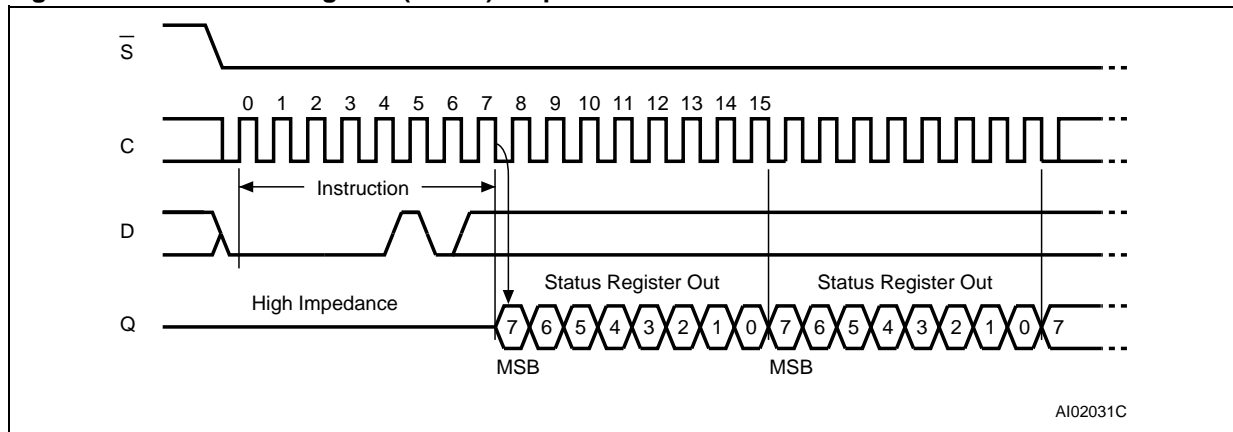

Table 6. Write Protected Block Size

Status Register Bits		Protected Block	Array Addresses Protected			
BP1	BP0		M95640	M95320	M95160	M95080
0	0	none	none	none	none	none
0	1	Upper quarter	1800h - 1FFFh	0C00h - 0FFFh	0600h - 07FFh	0300h - 03FFh
1	0	Upper half	1000h - 1FFFh	0800h - 0FFFh	0400h - 07FFh	0200h - 03FFh
1	1	Whole memory	0000h - 1FFFh	0000h - 0FFFh	0000h - 07FFh	0000h - 03FFh

of the protected area of the EEPROM have been written.

The initial delivery state of the BP1 and BP0 bits is 00, indicating a write-protection size of 0.

Software Protected Mode (SPM)

The act of writing a non-zero value to the BP1 and BP0 bits causes the Software Protected Mode (SPM) to be started. All attempts to write a byte or page in the protected area are ignored, even if the Write Enable Latch is set. However, writing is still allowed in the unprotected area of the memory array and to the SRWD, BP1 and BP0 bits of the status register, provided that the WEL bit is first set.

Hardware Protected Mode (HPM)

The Hardware Protected Mode (HPM) offers a higher level of protection, and can be selected by setting the SRWD bit after pulling down the \bar{W} pin or by pulling down the \bar{W} pin after setting the SRWD bit. The SRWD is set by the WSR instruction, provided that the WEL bit is first set. The setting of the SRWD bit can be made independently of, or at the same time as, writing a new value to the BP1 and BP0 bits.

Once the device is in the Hardware Protected Mode, the data bytes in the protected area of the memory array, *and* the content of the status register, are write-protected. The only way to re-enable writing new values to the status register is to pull the \bar{W} pin high. This causes the device to leave the Hardware Protected Mode, and to revert to being in the Software Protected Mode. (The value in the BP1 and BP0 bits will not have been changed).

Further details of the operation of Write Protect (\bar{W}) are given earlier, on page 3.

Typical Use of HPM and SPM

Write Protect (\bar{W}) can be driven by an output port of a microcontroller. It is important that Write Protect (\bar{W}) remains stable (permanently High, or permanently Low) throughout the duration of the Write Status Register sequence, shown in Figure 7).

It is also possible to connect it permanently to V_{SS} (by a solder connection, or through a pull-down resistor). The manufacturer of such a printed circuit board can take the memory device, still in its initial delivery state, and can solder it directly on to the board. After power on, the microcontroller can

Figure 7. Write Status Register (WRSR) Sequence

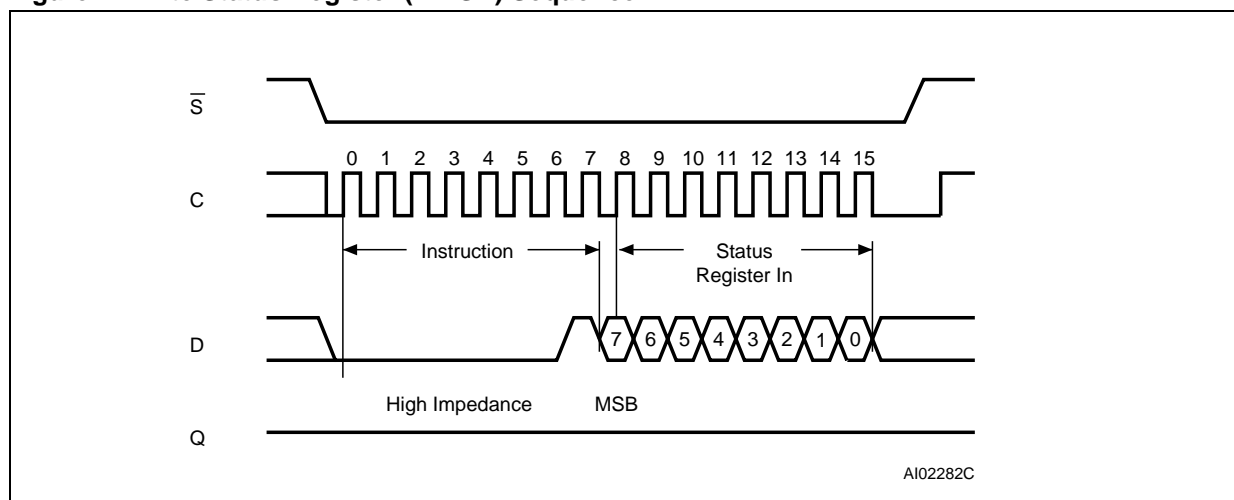
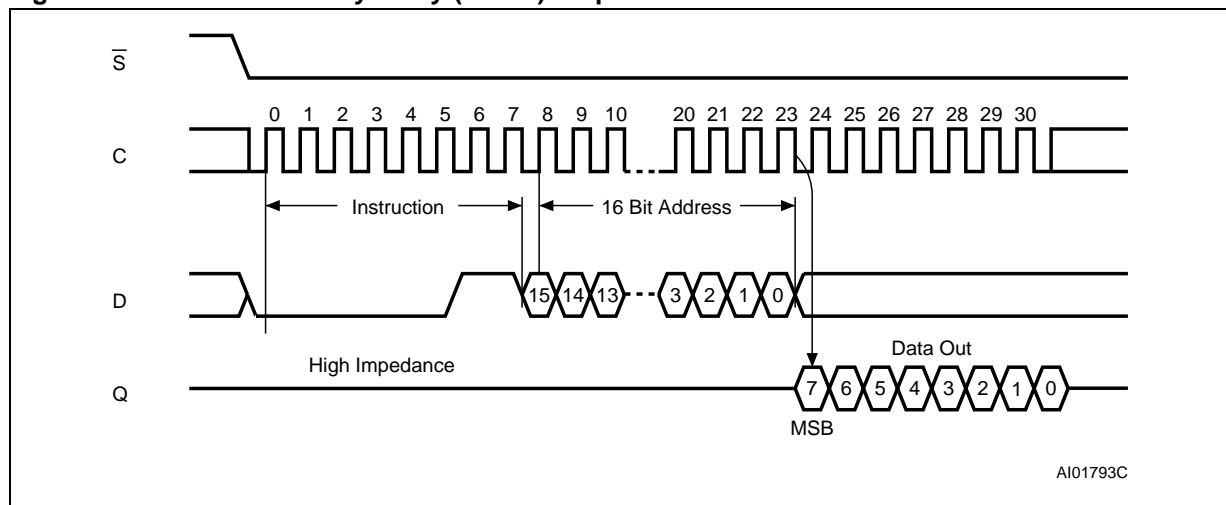

Figure 8. Read from Memory Array (READ) Sequence



Note: 1. Depending on the memory size, as shown in Table 7, the most significant address bits are Don't Care.

be instructed to write the protected data into the appropriate area of the memory. When it has finished, the appropriate values are written to the BP1, BP0 and SRWD bits, thereby putting the device in the hardware protected mode.

An alternative method is to write the protected data, and to set the BP1, BP0 and SRWD bits, before soldering the memory device to the board. Again, this results in the memory device being placed in its hardware protected mode.

If the \bar{W} pin has been connected to V_{SS} by a pull-down resistor, the memory device can be taken out of the hardware protected mode by driving the \bar{W} pin high, to override the pull-down resistor.

If the \bar{W} pin has been directly soldered to V_{SS} , there is only one way of taking the memory device out of the hardware protected mode: the memory device must be de-soldered from the board, and connected to external equipment in which the \bar{W} pin is allowed to be taken high.

Table 7. Address Range Bits

Device	M95640	M95320	M95160	M95080
Address Bits	A12-A0	A11-A0	A10-A0	A9-A0

Note: 1. Other address bits up to b15 are treated as Don't Care.

Read Operation

The chip is first selected by holding \bar{S} low. The serial one byte read instruction is followed by a two byte address (A15-A0), each bit being latched-in during the rising edge of the clock (C).

The data stored in the memory, at the selected address, is shifted out on the Q output pin. Each bit is shifted out during the falling edge of the clock (C) as shown in Figure 8. The internal address counter is automatically incremented to the next higher address after each byte of data has been shifted out. The data stored in the memory, at the next address, can be read by successive clock

Figure 9. Write Enable (WREN) Sequence

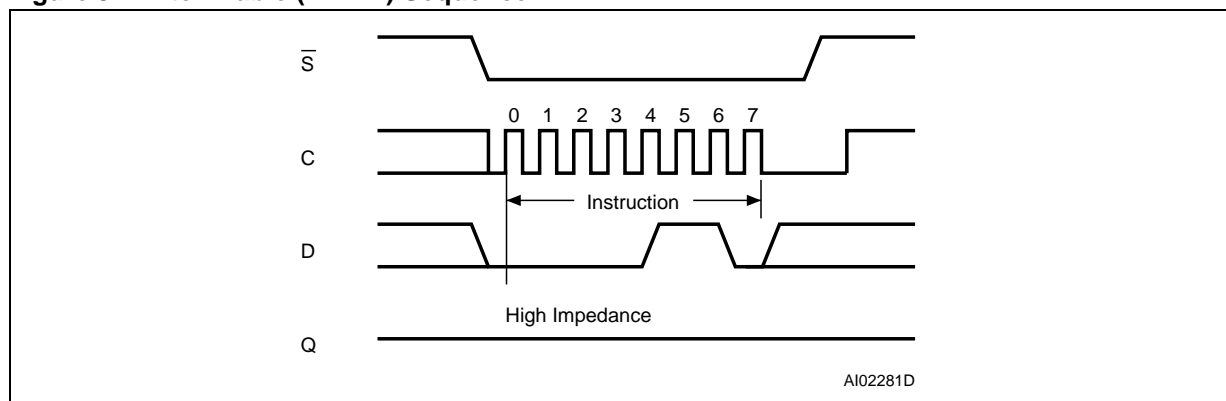
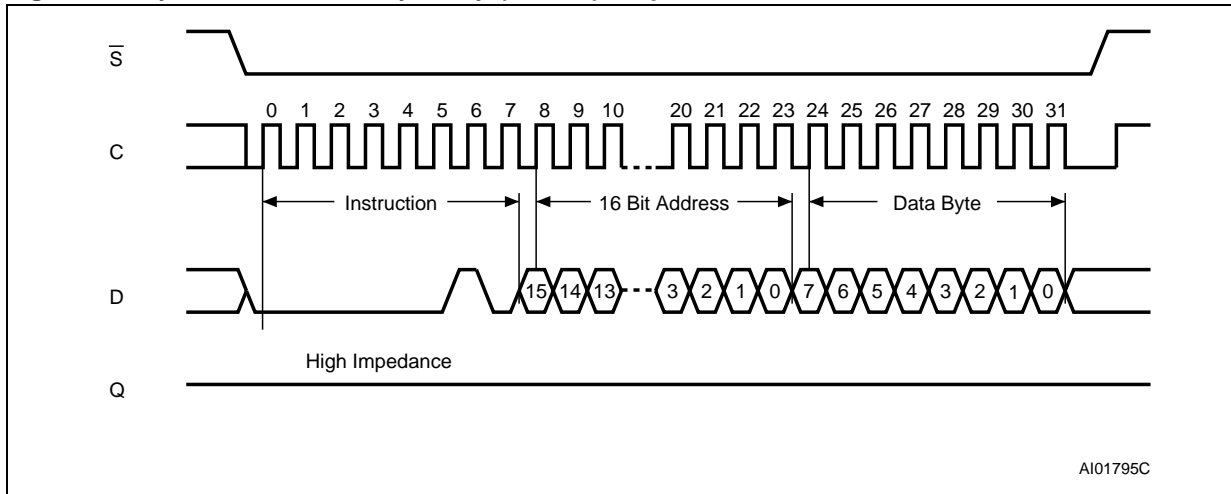

Figure 10. Byte Write to Memory Array (WRITE) Sequence



Note: 1. Depending on the memory size, as shown in Table 7, the most significant address bits are Don't Care.

pulses. When the highest address is reached, the address counter rolls over to "0000h", allowing the read cycle to be continued indefinitely. The read operation is terminated by deselection of the chip. The chip can be deselected at any time during data output. If a read instruction is received during

a write cycle, it is rejected, and the memory device deselects itself.

Byte Write Operation

Before any write can take place, the WEL bit must be set, using the WREN instruction. The write state is entered by selecting the chip, issuing three

Figure 11. Page Write to Memory Array (WRITE) Sequence

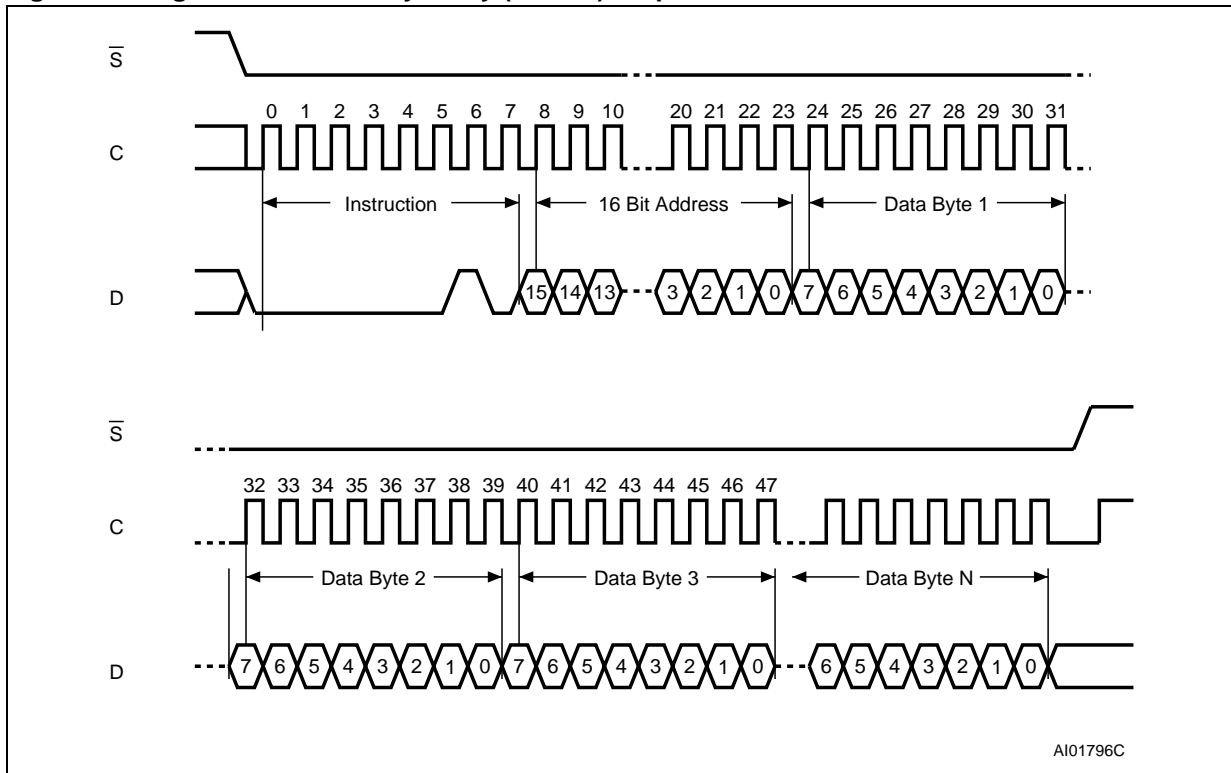

Note: 1. Depending on the memory size, as shown in Table 7, the most significant address bits are Don't Care.

bytes of instruction and address, and one byte of data. Chip Select (\overline{S}) must remain low throughout the operation, as shown in Figure 10. The product must be deselected just after the eighth bit of the data byte has been latched in, as shown in Figure 10, otherwise the write process is cancelled. As soon as the memory device is deselected, the self-timed internal write cycle is initiated. While the write is in progress, the status register may be read to check the status of the SRWD, BP1, BP0, WEL and WIP bits. In particular, WIP contains a '1' during the self-timed write cycle, and a '0' when the cycle is complete, (at which point the write enable latch is also reset).

Page Write Operation

A maximum of 32 bytes of data can be written during one Write time, t_W , provided that they are all to the same page (see Figure 5). The Page Write operation is the same as the Byte Write operation, except that instead of deselecting the device after the first byte of data, up to 31 additional bytes can be shifted in (and then the device is deselected after the last byte).

Any address of the memory can be chosen as the first address to be written. If the address counter reaches the end of the page (an address of the form xxxx xxxx xxx1 1111) and the clock continues, the counter rolls over to the first address of the same page (xxxx xxxx xxx0 0000) and over-writes any previously written data.

As before, the Write cycle only starts if the \overline{S} transition occurs just after the eighth bit of the last data byte has been received, as shown in Figure 11.

DATA PROTECTION AND PROTOCOL SAFETY

To protect the data in the memory from inadvertent corruption, the memory device only responds to correctly formulated commands. The main security measures can be summarised as follows:

- The WEL bit is reset at power-up.
- \overline{S} must rise after the eighth clock count (or multiple thereof) in order to start a non-volatile write cycle (in the memory array or in the status register).
- Accesses to the memory array are ignored during the non-volatile programming cycle, and the programming cycle continues unaffected.

- After execution of a WREN, WRDI, or RDSR instruction, the chip enters a wait state, and waits to be deselected.
- Invalid \overline{S} and \overline{HOLD} transitions are ignored.

POWER ON STATE

After power-on, the memory device is in the following state:

- low power stand-by state
- deselected (after power-on, a high-to-low transition is required on the \overline{S} input before any operations can be started).
- not in the hold condition
- the WEL bit is reset
- the SRWD, BP1 and BP0 bits of the status register are unchanged from the previous power-down (they are non-volatile bits).

Table 8. Initial Status Register Format

b7								b0
0	0	0	0	0	0	0	0	0

INITIAL DELIVERY STATE

The device is delivered with the memory array in a fully erased state (all data set at all 1s, FFh). The status register bits are initialized to 00h, as shown in Table 8.

Table 9. Input Parameters¹ ($T_A = 25\text{ }^\circ\text{C}$, $f = 5\text{ MHz}$)

Symbol	Parameter	Test Condition	Min.	Max.	Unit
C_{OUT}	Output Capacitance (Q)			8	pF
C_{IN}	Input Capacitance (other pins)			6	pF

Note: 1. Sampled only, not 100% tested.



Table 10. DC Characteristics(T_A = 0 to 70 °C, -40 to 85 °C or -40 to 125 °C; V_{CC} = 4.5 to 5.5 V)(T_A = 0 to 70 °C or -40 to 85 °C; V_{CC} = 2.7 to 3.6 V)(T_A = 0 to 70 °C or -40 to 85 °C; V_{CC} = 2.5 to 5.5 V)(T_A = 0 to 70 °C or -20 to 85 °C; V_{CC} = 1.8 to 3.6 V)

Symbol	Parameter	Voltage Range	Temp. Range	Test Condition	Min.	Max.	Unit
I _{LI}	Input Leakage Current	all	all	V _{IN} = V _{SS} or V _{CC}		± 2	μA
I _{LO}	Output Leakage Current	all	all	All inputs driven to V _{SS} or V _{CC}		± 2	μA
I _{CC}	Supply Current	4.5-5.5	6	C = 0.1V _{CC} /0.9V _{CC} , at 5 MHz, V _{CC} = 5 V, Q = open		4	mA
		4.5-5.5	3	C = 0.1V _{CC} /0.9V _{CC} , at 2 MHz, V _{CC} = 5 V, Q = open		4	mA
		2.7-3.6	6	C = 0.1V _{CC} /0.9V _{CC} , at 5 MHz, V _{CC} = 2.7 V, Q = open		3	mA
		2.5-5.5	6	C = 0.1V _{CC} /0.9V _{CC} , at 2 MHz, V _{CC} = 2.5 V, Q = open		2	mA
		1.8-3.6	5	C = 0.1V _{CC} /0.9V _{CC} , at 1 MHz, V _{CC} = 1.8 V, Q = open		2	mA
I _{CC1}	Supply Current (Stand-by)	4.5-5.5	6	$\bar{S} = V_{CC}$, V _{IN} = V _{SS} or V _{CC} , V _{CC} = 5 V		10	μA
		4.5-5.5	3	$\bar{S} = V_{CC}$, V _{IN} = V _{SS} or V _{CC} , V _{CC} = 5 V		10	μA
		2.7-3.6	6	$\bar{S} = V_{CC}$, V _{IN} = V _{SS} or V _{CC} , V _{CC} = 2.7 V		2	μA
		2.5-5.5	6	$\bar{S} = V_{CC}$, V _{IN} = V _{SS} or V _{CC} , V _{CC} = 2.5 V		2	μA
		1.8-3.6	5	$\bar{S} = V_{CC}$, V _{IN} = V _{SS} or V _{CC} , V _{CC} = 1.8 V		1	μA
V _{IL}	Input Low Voltage	all	all		- 0.3	0.3 V _{CC}	V
V _{IH}	Input High Voltage	all	all		0.7 V _{CC}	V _{CC} +1	V
V _{OL} ¹	Output Low Voltage	4.5-5.5	6	I _{OL} = 2 mA		0.4	V
		4.5-5.5	3	I _{OL} = 2 mA		0.4	V
		2.7-3.6	6	I _{OL} = 1.5 mA		0.4	V
		2.5-5.5	6	I _{OL} = 1.5 mA		0.4	V
		1.8-3.6	5	I _{OL} = 0.15 mA		0.3	V
V _{OH} ¹	Output High Voltage	4.5-5.5	6	I _{OH} = -2 mA	0.8 V _{CC}		V
		4.5-5.5	3	I _{OH} = -2 mA	0.8 V _{CC}		V
		2.7-3.6	6	I _{OH} = -0.4 mA	0.8 V _{CC}		V
		2.5-5.5	6	I _{OH} = -0.4 mA	0.8 V _{CC}		V
		1.8-3.6	5	I _{OH} = -0.1 mA	0.8 V _{CC}		V

Note: 1. For all 5V range devices, the device meets the output requirements for both TTL and CMOS standards.

Table 11A. AC Characteristics

Symbol	Alt.	Parameter	M95640, M95320, M95160, M95080				Unit
			V _{CC} =4.5 to 5.5 V T _A =0 to 70°C or -40 to 85°C		V _{CC} =4.5 to 5.5 V T _A =-40 to 125°C		
			Min	Max	Min	Max	
f _C	f _{SCK}	Clock Frequency	D.C.	5	D.C.	2	MHz
t _{SLCH}	t _{CSS1}	\overline{S} Active Setup Time	90		200		ns
t _{SHCH}	t _{CSS2}	\overline{S} Not Active Setup Time	90		200		ns
t _{SHSL}	t _{CS}	\overline{S} Deselect Time	100		200		ns
t _{CHSH}	t _{CSH}	\overline{S} Active Hold Time	90		200		ns
t _{CHSL}		\overline{S} Not Active Hold Time	90		200		ns
t _{CH} ¹	t _{CLH}	Clock High Time	90		200		ns
t _{CL} ¹	t _{CLL}	Clock Low Time	90		200		ns
t _{CLCH} ²	t _{RC}	Clock Rise Time		1		1	μs
t _{CHCL} ²	t _{FC}	Clock Fall Time		1		1	μs
t _{DVCH}	t _{DSU}	Data In Setup Time	20		40		ns
t _{CHDX}	t _{DH}	Data In Hold Time	30		50		ns
t _{HHCH}	t _{CD}	Clock Low Hold Time after \overline{HOLD} not Active	70		140		ns
t _{HLCH}		Clock Low Hold Time after \overline{HOLD} Active	40		90		ns
t _{CLHL}		Clock Low Set-up Time before \overline{HOLD} Active	0		0		ns
t _{CLHH}		Clock Low Set-up Time before \overline{HOLD} not Active	0		0		ns
t _{SHQZ} ²	t _{DIS}	Output Disable Time		100		250	ns
t _{CLQV}	t _V	Clock Low to Output Valid		60		150	ns
t _{CLQX}	t _{HO}	Output Hold Time	0		0		ns
t _{QLQH} ²	t _{RO}	Output Rise Time		50		100	ns
t _{QHQL} ²	t _{FO}	Output Fall Time		50		100	ns
t _{HHQX} ²	t _{LZ}	\overline{HOLD} High to Output Low-Z		50		100	ns
t _{HLQZ} ²	t _{HZ}	\overline{HOLD} Low to Output High-Z		100		250	ns
t _w	t _{wc}	Write Time		10		10	ms

Note: 1. t_{CH} + t_{CL} ≥ 1 / f_C.

2. Value guaranteed by characterization, not 100% tested in production.

Table 11B. AC Characteristics

Symbol	Alt.	Parameter	M95xxx-V		M95xxx-W		M95xxx-R		Unit
			V _{CC} =2.7 to 3.6 V T _A =0 to 70°C or -40 to 85°C		V _{CC} =2.5 to 5.5 V T _A =0 to 70°C or -40 to 85°C		V _{CC} =1.8 to 3.6 V T _A =0 to 70°C or -20 to 85°C		
			Min	Max	Min	Max	Min	Max	
f _c	f _{SCK}	Clock Frequency	D.C.	5	D.C.	2	D.C.	1	MHz
t _{SLCH}	t _{CS1}	\overline{S} Active Setup Time	90		200		400		ns
t _{SHCH}	t _{CS2}	\overline{S} Not Active Setup Time	90		200		400		ns
t _{SHSL}	t _{CS}	\overline{S} Deselect Time	100		200		300		ns
t _{CHSH}	t _{CSH}	\overline{S} Active Hold Time	90		200		400		ns
t _{CHSL}		\overline{S} Not Active Hold Time	90		200		400		ns
t _{CH} ¹	t _{CLH}	Clock High Time	90		200		400		ns
t _{CL} ¹	t _{CLL}	Clock Low Time	90		200		400		ns
t _{CLCH} ²	t _{RC}	Clock Rise Time		0.05		1		1	μs
t _{CHCL} ²	t _{FC}	Clock Fall Time		0.05		1		1	μs
t _{DVCH}	t _{DSU}	Data In Setup Time	20		40		60		ns
t _{CHDX}	t _{DH}	Data In Hold Time	30		50		100		ns
t _{HHCH}	t _{CD}	Clock Low Hold Time after \overline{HOLD} not Active	70		140		350		ns
t _{HLCH}		Clock Low Hold Time after \overline{HOLD} Active	40		90		200		ns
t _{CLHL}		Clock Low Set-up Time before \overline{HOLD} Active	0		0		0		ns
t _{CLHH}		Clock Low Set-up Time before \overline{HOLD} not Active	0		0		0		ns
t _{SHQZ} ²	t _{DIS}	Output Disable Time		100		250		500	ns
t _{CLQV}	t _V	Clock Low to Output Valid		60		150		380	ns
t _{CLQX}	t _{HO}	Output Hold Time	0		0		0		ns
t _{QLQH} ²	t _{RO}	Output Rise Time		50		100		200	ns
t _{QHQL} ²	t _{FO}	Output Fall Time		50		100		200	ns
t _{HHQX} ²	t _{LZ}	\overline{HOLD} High to Output Low-Z		50		100		250	ns
t _{HLQZ} ²	t _{HZ}	\overline{HOLD} Low to Output High-Z		100		250		500	ns
t _w	t _{wc}	Write Time		10		10		10	ms

Note: 1. t_{CH} + t_{CL} ≥ 1 / f_c.

2. Value guaranteed by characterization, not 100% tested in production.

Table 12. AC Measurement Conditions

Input Rise and Fall Times	≤ 50 ns
Input Pulse Voltages	0.2V _{CC} to 0.8V _{CC}
Input and Output Timing Reference Voltages	0.3V _{CC} to 0.7V _{CC}
Output Load	C _L = 100 pF

Note: 1. Output Hi-Z is defined as the point where data is no longer driven.

Figure 12. AC Testing Input Output Waveforms

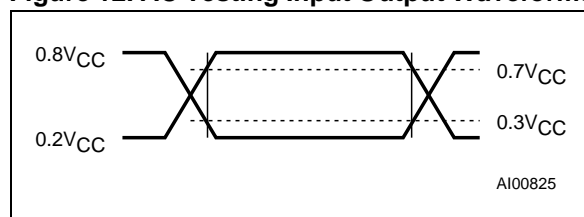

Figure 13. Serial Input Timing

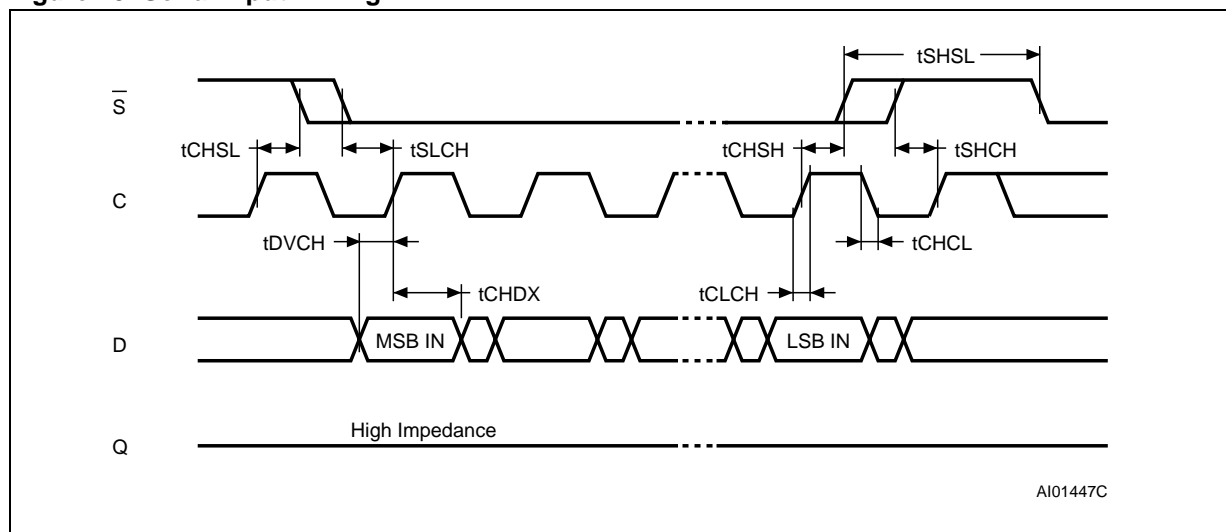

Figure 14. Hold Timing

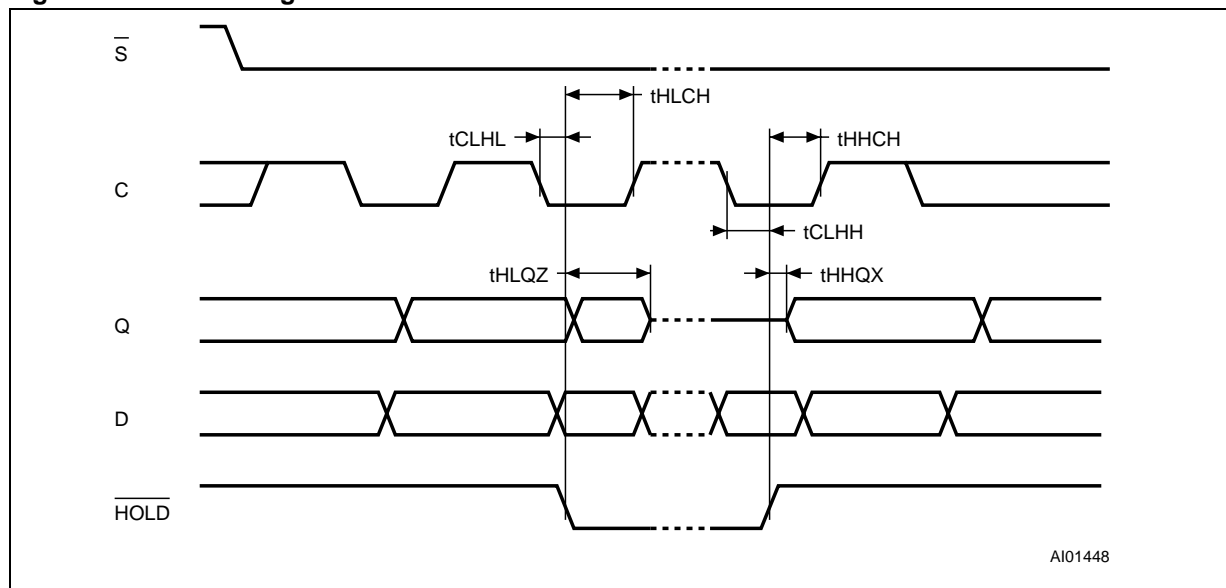
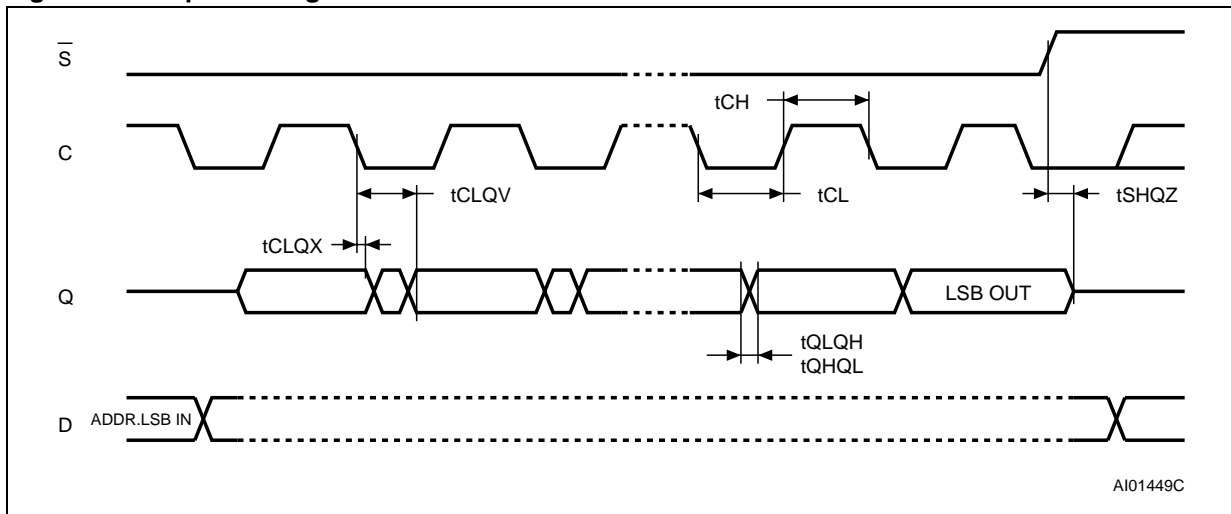

Figure 15. Output Timing



ORDERING INFORMATION

The notation used for the device number is as shown in Table 13. For a list of available options

(speed, package, etc.) or for further information on any aspect of this device, please contact your nearest ST Sales Office.

Table 13. Ordering Information Scheme

Example:

M95640 - W MN 6 T

Memory Capacity³		Option	
640	64 Kbit (8K x 8) with positive clock strobe	T	Tape and Reel Packing
320	32 Kbit (4K x 8) with positive clock strobe	Temperature Range	
160	16 Kbit (2K x 8) with positive clock strobe	5	-20 °C to 85 °C
080	8 Kbit (1K x 8) with positive clock strobe	6	-40 °C to 85 °C
Operating Voltage		3 ¹	-40 °C to 125 °C
blank	4.5 V to 5.5 V	Package	
V	2.7 V to 3.6 V	BN	PDIP8 (0.25 mm frame)
W	2.5 V to 5.5 V	MN	SO8 (150 mil width)
S ²	1.8 V to 3.6 V	DL ⁴	TSSOP14 (169 mil width)
		DW ⁵	TSSOP8 (169 mil width)

- Note: 1. Produced with High Reliability Certified Flow (HRCF), in V_{CC} range 4.5 V to 5.5 V only.
 2. The -S version (V_{CC} range 1.8 V to 3.6 V) only available in temperature ranges 5 or 1.
 3. All devices use a positive clock strobe: Data In is strobed on the rising edge of the clock (C) and Data Out is synchronised from the falling edge of the clock.
 4. TSSOP14, 169 mil width, package is available for the M95640 series only.
 5. Not available on all products. Please contact your ST Sales Office for further information.



M95640, M95320, M95160, M95080

PDIP8 – 8 pin Plastic DIP, 0.25mm lead frame

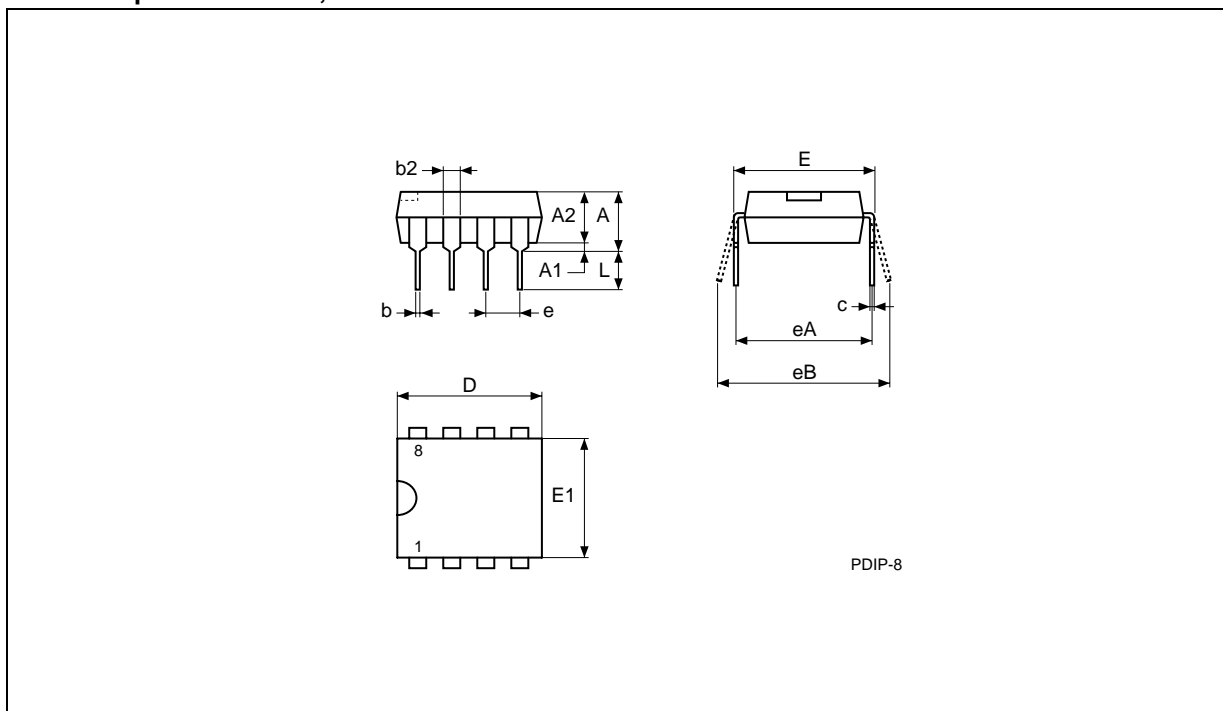

Note: 1. Drawing is not to scale.

PDIP8 – 8 pin Plastic DIP, 0.25mm lead frame

Symb.	mm			inches		
	Typ.	Min.	Max.	Typ.	Min.	Max.
A			5.33			0.210
A1		0.38			0.015	
A2	3.30	2.92	4.95	0.130	0.115	0.195
b	0.46	0.36	0.56	0.018	0.014	0.022
b2	1.52	1.14	1.78	0.060	0.045	0.070
c	0.25	0.20	0.36	0.010	0.008	0.014
D	9.27	9.02	10.16	0.365	0.355	0.400
E	7.87	7.62	8.26	0.310	0.300	0.325
E1	6.35	6.10	7.11	0.250	0.240	0.280
e	2.54	–	–	0.100	–	–
eA	7.62	–	–	0.300	–	–
eB			10.92			0.430
L	3.30	2.92	3.81	0.130	0.115	0.150
N	8			8		

SO8 narrow – 8 lead Plastic Small Outline, 150 mils body width

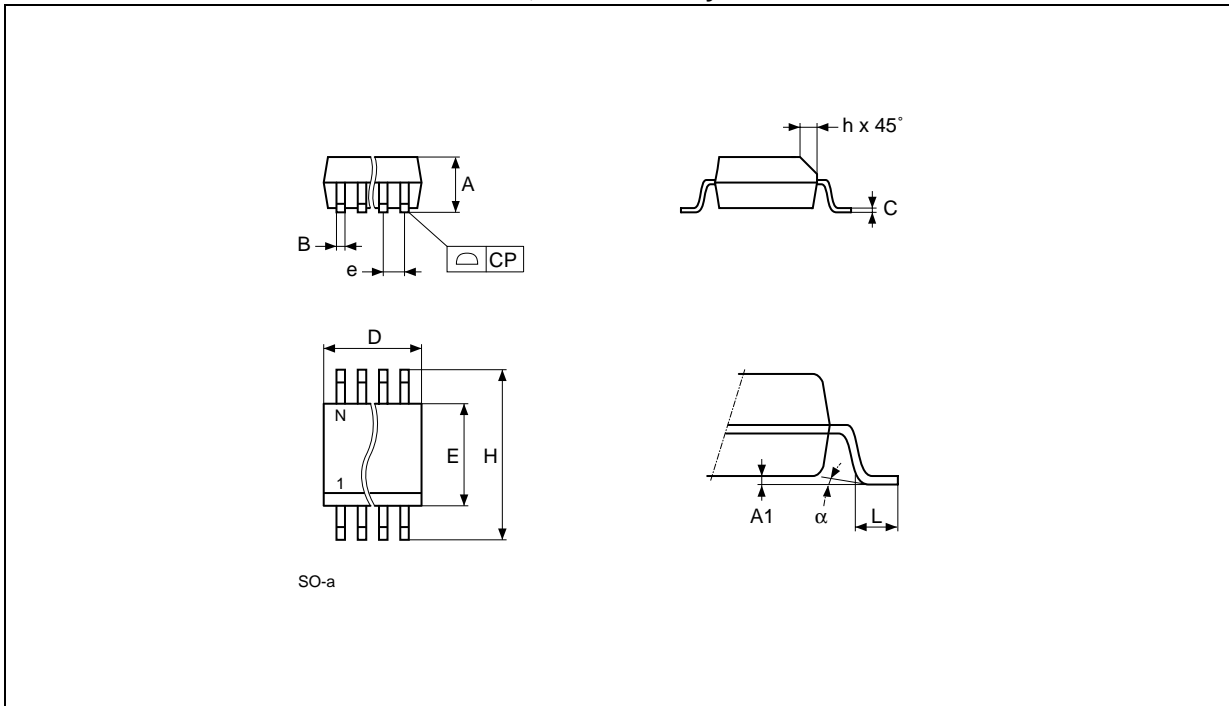

Note: Drawing is not to scale.

SO8 narrow – 8 lead Plastic Small Outline, 150 mils body width

Symb.	mm			inches		
	Typ.	Min.	Max.	Typ.	Min.	Max.
A		1.35	1.75		0.053	0.069
A1		0.10	0.25		0.004	0.010
B		0.33	0.51		0.013	0.020
C		0.19	0.25		0.007	0.010
D		4.80	5.00		0.189	0.197
E		3.80	4.00		0.150	0.157
e	1.27	–	–	0.050	–	–
H		5.80	6.20		0.228	0.244
h		0.25	0.50		0.010	0.020
L		0.40	0.90		0.016	0.035
α		0°	8°		0°	8°
N	8			8		
CP			0.10			0.004

TSSOP8 – 8 lead Thin Shrink Small Outline

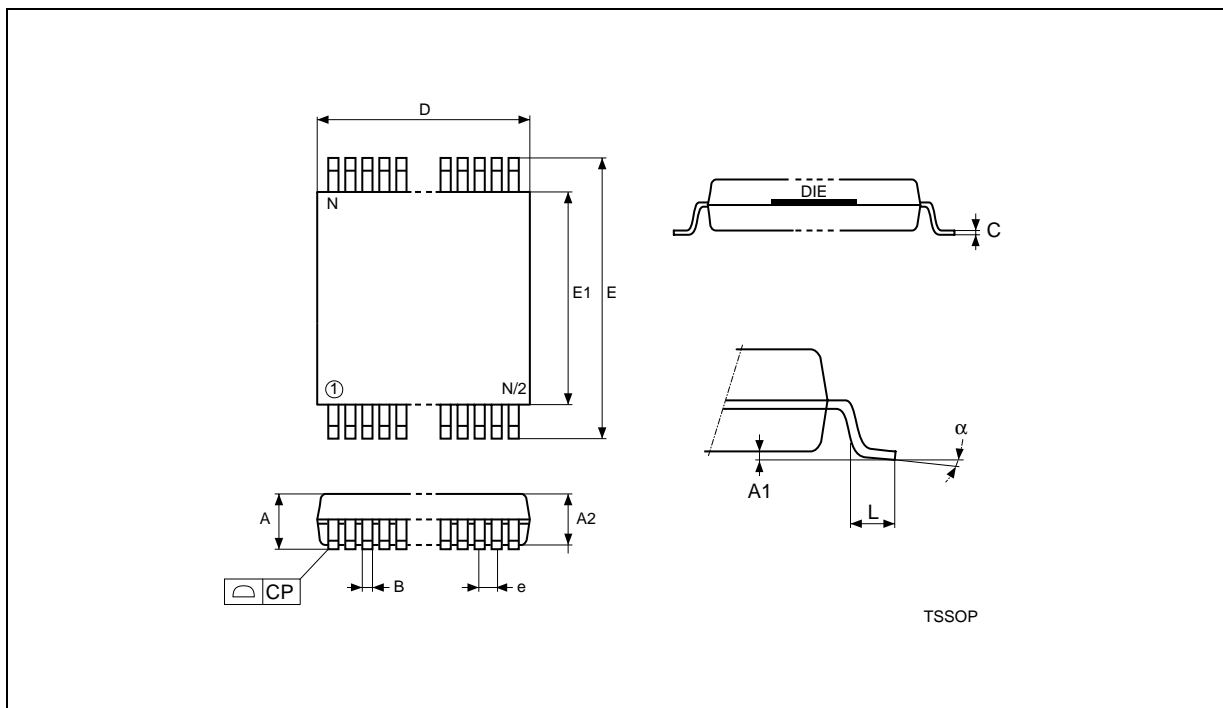

Note: 1. Drawing is not to scale.

TSSOP8 – 8 lead Thin Shrink Small Outline

Symb.	mm			inches		
	Typ.	Min.	Max.	Typ.	Min.	Max.
A			1.10			0.043
A1		0.05	0.15		0.002	0.006
A2		0.85	0.95		0.033	0.037
B		0.19	0.30		0.007	0.012
C		0.09	0.20		0.004	0.008
D		2.90	3.10		0.114	0.122
E		6.25	6.50		0.246	0.256
E1		4.30	4.50		0.169	0.177
e	0.65	–	–	0.026	–	–
L		0.50	0.70		0.020	0.028
alpha		0°	8°		0°	8°
N	8			8		
CP			0.08			0.003

TSSOP14 - 14 lead Thin Shrink Small Outline

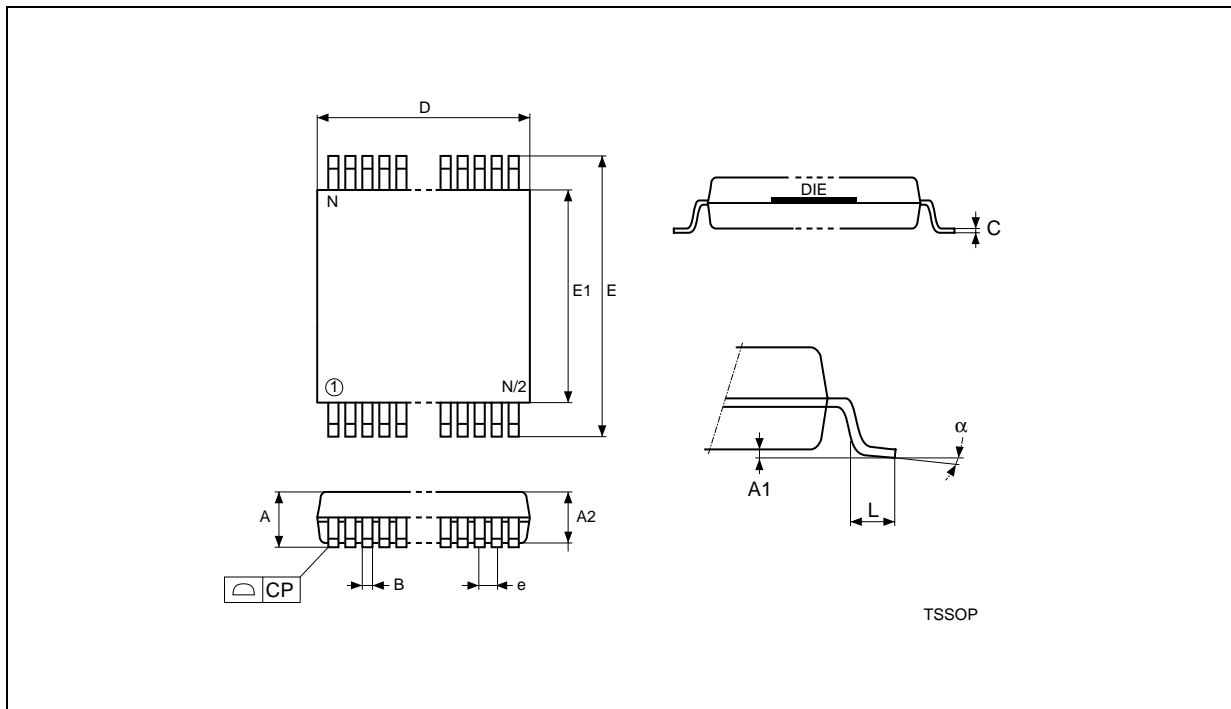

Note: 1. Drawing is not to scale.

TSSOP14 - 14 lead Thin Shrink Small Outline

Symb.	mm			inches		
	Typ.	Min.	Max.	Typ.	Min.	Max.
A			1.10			0.043
A1		0.05	0.15		0.002	0.006
A2		0.85	0.95		0.033	0.037
B		0.19	0.30		0.007	0.012
C		0.09	0.20		0.004	0.008
D		4.90	5.10		0.193	0.197
E		6.25	6.50		0.246	0.256
E1		4.30	4.50		0.169	0.177
e	0.65	—	—	0.026	—	—
L		0.50	0.70		0.020	0.028
alpha		0°	8°		0°	8°
N	14			14		
CP			0.08			0.003

Table 14. Revision History

Date	Description of Revision
13-Jul-2000	Human Body Model meets JEDEC std (Table 2). Minor adjustments on pp 1,11,15. New clause on p7. Addition of TSSOP8 package on pp 1, 2, Ordering Info, Mechanical Data
16-Mar-2001	Test condition added I _{LI} and I _{LO} , and specification of t _{DLDH} and t _{DHDL} removed. t _{CLCH} , t _{CHCL} , t _{DLDH} and t _{DHDL} changed to 50ns for the -V range. “-V” Voltage range changed to “2.7V to 3.6V” throughout. Maximum lead soldering time and temperature conditions updated. Instruction sequence illustrations updated. “Bus Master and Memory Devices on the SPI bus” illustration updated. Package Mechanical data updated.

Information furnished is believed to be accurate and reliable. However, STMicroelectronics assumes no responsibility for the consequences of use of such information nor for any infringement of patents or other rights of third parties which may result from its use. No license is granted by implication or otherwise under any patent or patent rights of STMicroelectronics. Specifications mentioned in this publication are subject to change without notice. This publication supersedes and replaces all information previously supplied. STMicroelectronics products are not authorized for use as critical components in life support devices or systems without express written approval of STMicroelectronics.

The ST logo is registered trademark of STMicroelectronics
All other names are the property of their respective owners

© 2001 STMicroelectronics - All Rights Reserved

STMicroelectronics GROUP OF COMPANIES
Australia - Brazil - China - Finland - France - Germany - Hong Kong - India - Italy - Japan - Malaysia - Malta - Morocco -
Singapore - Spain - Sweden - Switzerland - United Kingdom - U.S.A.

www.st.com

