

SHARP SERVICE MANUAL

SY8A725WG3///

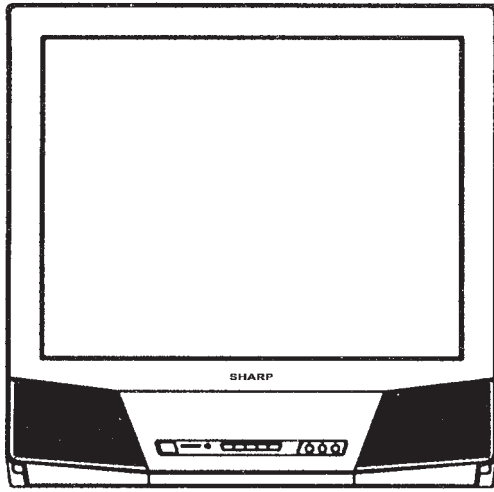

COLOUR TELEVISION
Chassis No. SS-1

MODEL 25WG3

In the interests of user-safety (Required by safety regulations in some countries) the set should be restored to its original condition and only parts identical to those specified be used.

CONTENTS

	Page		Page
• FEATURE	2	• WAVEFORMS	15
• SPECIFICATIONS	2	• DESCRIPTION OF SCHEMATIC DIAGRAM	15
• IMPORTANT SERVICE NOTES	3	• BLOCK DIAGRAM	16
• ADJUSTMENT PRECAUTIONS	3	• CHASSIS LAYOUT	22
• SERVICE MODE	4	• SCHEMATIC DIAGRAM	24
• SERVICE ADJUSTMENT	7	• PRINTED WIRING BOARD ASSEMBLIES	32
• TROUBLESHOOTING	13	• PARTS LIST	37
• SOLID STATE DEVICE BASE DIAGRAM	14		

WARNING

The chassis in this receiver is partially hot. Use an isolation transformer between the line cord plug and power receptacle, when servicing this chassis.
To prevent electric shock, do not remove cover. No user-serviceable parts inside. Refer servicing to qualified service personnel.

SHARP CORPORATION

SERVICE MANUAL
COLOUR TELEVISION
MODEL 25WG3

FEATURE

- PAL B/G, AV NTSC System
- Auto Search Tuning System
- 100-CH Program Memory
- AV Stereo sound
- High Contrast Picture (Black Stretch Circuit)
- CATV (Hyper Band) Ready<Used Frequency Synthesizer Tuner>
- 7 Mode Surround system
- Picture Signal Improvement Circuit
- 2 Language OSD
- On Timer/ Sleep Timer/ Reminder Timer
- Picture Noise Reduction Circuit
- Blue Back Noise Mute
- Front AV-In & Rear AV-In/Out Terminals

SPECIFICATIONS

Convergence	Self Convergence System
Focus	Bi-Potential, Uni-Potential Electrostatic
Sweep Deflection	Magnetic
Intermediate Frequency	
Picture IF Carrier	38.9 MHz
Sound IF Carrier	33.16/33.4 MHz
Colour Sub-Carrier	34.47 MHz
Power Input	AC 110-240V, 50/60Hz (Auto)
Power Consumption	130W
Audio Power Output Rating	7.5 W x 2(Max)
Speaker	
Size	10 cm Round x 2pcs.
Voice Coil Impedance	8 ohm at 400 Hz
Aerial Input Impedance	75 ohm Unbalanced
Receiving Channels	
PAL-B/G	
VHF	E2(44.25MHz) thru E12(463.25 MHz)
UHF	E21(471.25 MHz) thru E69(863.25 MHz)
Dimensions (Approx.)	574.0 (W) x 564.5 (H) x 499.0 (D) mm
Weight (Approx.)	28 kg
Cabinet Material	Plastics

Specifications are subject to change without notice.

ADJUSTMENT PRECAUTIONS

This model's setting are adjusted in two different ways: through the I²C bus control and in the conventional analog manner. The adjustments via the I²C bus control include preset-only items and variable data.

1. Calling the service mode by the microprocessor.

- (1) Set the switch S1006 to the service mode position, and the microprocessor is put service mode. (Adjustment through the I²C bus control)
- (2) Press the CH UP key on the remote controller to get ready to select the mode one by one.
- (3) Press the CH DOWN key on the remote controller to select the modes reversely one by one.
- (4) Using the VOLUME UP/ VOLUME DOWN key on the remote controller, the data can be modified.
- (5) Set the switch S1006 to the normal mode (OFF) position, and the microprocessor is put out of the service mode.

2. Factory Presettings.

- (1) Set the switch S1006 to the service mode position and turn on the main power switch. Initial values are automatically preset only when a new E²PROM is used (judgement with the first 4 bytes).
- (2) The initial data are preset as listed in page 5-6.
- (3) Make sure the data need modify or not (Initial data).

IMPORTANT

Note: Once the chassis has been put together and ready to be POWER ON for the FIRST TIME, make sure to set the switch S1006 to the service mode position first and then turn on the main power switch (See 2-(1) above).

IMPORTANT SERVICE NOTES

Maintenance and repair of this receiver should be done by qualified service personnel only.

SERVICING OF HIGH VOLTAGE SYSTEM AND PICTURE TUBE

When servicing the high voltage system, remove static charge from it by connecting a 10k ohm Resistor in series with an insulated wire (such as a test probe) between picture tube dag and 2nd anode lead. (AC line cord should be disconnected from AC outlet.)

1. Picture tube in this receiver employs integral implosion protection.
2. Replace with tube of the same type number for continued safety.
3. Do not lift picture tube by the neck.
4. Handle the picture tube only when wearing shatterproof goggles and after discharging the high voltage completely.

X-RAY

This receiver is designed so that any X-Ray radiation is kept to an absolute minimum. Since certain malfunctions or servicing many produce potentially hazardous radiation with prolonged exposure at close range, the following precautions should be observed:

1. When repairing the circuit, be sure not to increase the high voltage to more than 32.0 kV (at beam 0 μ A) for the set.
2. To keep the set in a normal operation, be sure to make it function on 29.0 \pm 1.5kV (at beam 1300 μ A) in the case of the set. The set has been factory-Adjusted to the above mentioned high voltage.
3. Do not substitute a picture tube with unauthorized types and/or brands which may cause excess X-Ray radiation.

BEFORE RETURNING THE RECEIVER

Before returning the receiver to the user, perform the following safety checks.

1. Inspect all lead dress to make certain that the leads are not pinched or that hardware is not lodged between the chassis and other metal parts in the receiver.
2. Inspect all protective device such as non-metallic control knobs, insulating fishpapers, cabinet backs, adjustment and compartment covers or shields, isolation resistor-capacity networks, mechanical insulators etc.

SERVICE MODE

1.) In the Service Mode, Key is used to select the mode in the following order.

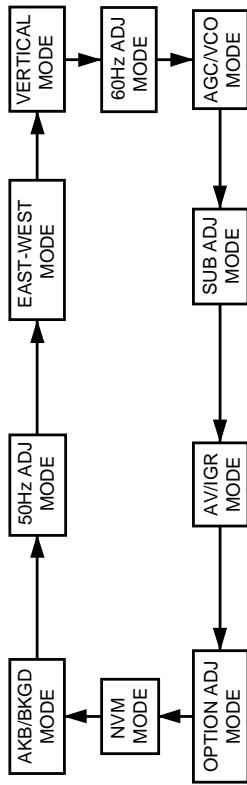

FORWARD: CH UP
REVERSE: CH DOWN

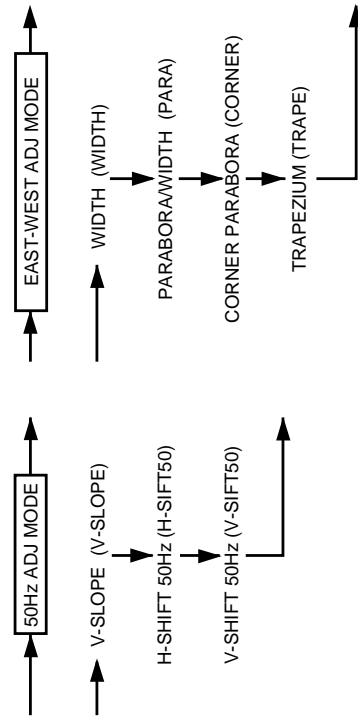

In the direction of arrow: CH UP key
In the opposite direction : CH DOWN key
* The character in parentheses appear on the on-screen display.

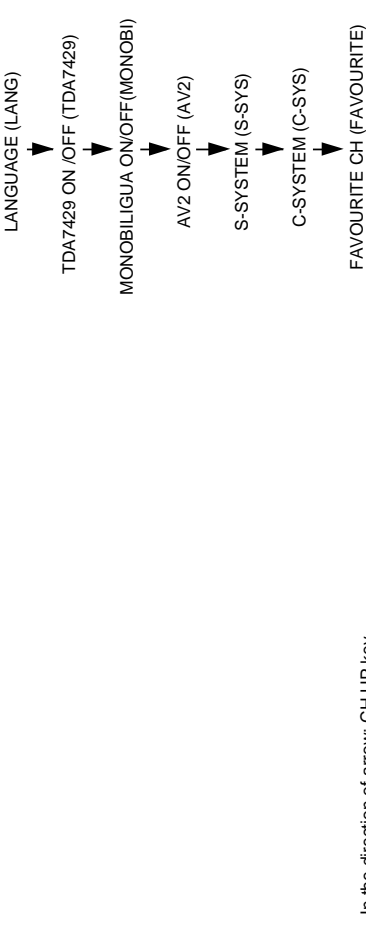
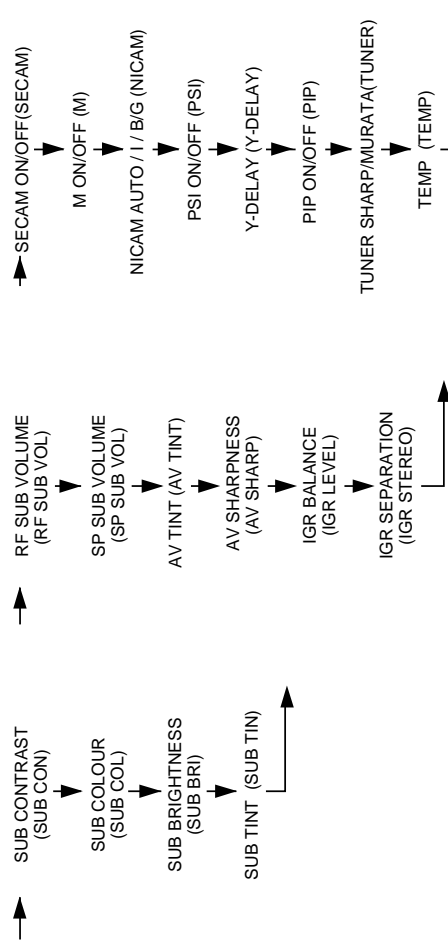
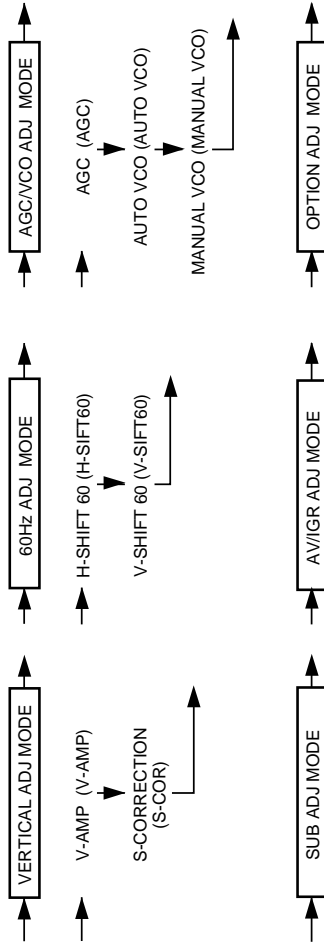

In the direction of arrow: CH UP key
In the opposite direction: CH DOWN key
* The character in parentheses appear on the on-screen display.

INITIAL SETTING OF E²PROM

E ² PROM ITEMS	DATA LENGTH	INITIAL DATA	REMARK
AKB	ON/OFF	ON	
WHITE POINT (R)	0~ 63	32	
WHITE POINT (G)	0~ 63	32	
WHITE POINT (B)	0~ 63	32	
V-SLOPE	0~ 63	25	
H-SHIFT 50Hz	0~ 63	25(TV)	
V-SHIFT 50Hz	0~ 63	32 (TV)	
WIDTH	0~ 63	48	
PARA	0~ 63	36	
CORNER	0~ 63	28	
TRAP	0~ 63	32	
V-AMP	0~ 63	17	
S-COR	0~ 63	15	
H-SHIFT 60Hz	0~ 63	31(TV)	
V-SHIFT 60Hz	0~ 63	26(TV)	
AGC	0~ 63	15	
AUTO VCO	0~127	NG.55	
MANUAL VCO	0~127	55	
SUB-CONTRAST	0~ 63	63	
SUB COLOUR	0~ 63	19	
SUB BRIGHT	0~ 63	31	
SUB TINT	0~ 63	27	
RF SUB VOLUME	0~ 63	35	
SP SUB VOLUME	0~ 63	55	
AV TINT	0~ 63	00	
AV SHARP	0~ 63	00	
IGR LEVEL	0~10	05	
IGR STEREO	0~ 31	24	
SECAM	ON/OFF	ON	
M	ON/OFF	ON	
NICAM	AUTO/BG/I	AUTO	
PSI	ON/OFF	ON	
Y-DELAY	0~ 15	09(TV), 09(AV)	
PIP	ON/OFF	OFF	
TUNER	SHARP/MURATA	SHARP	
TEMP	0~1	0	
LANG	ON/OFF	ON	
TDA7429	ON/OFF	ON	
MONOBI	ON/OFF	ON	
AV2	ON/OFF	ON	
S-SYS	ON/OFF	ON	
C-SYS	ON/OFF	ON	
FAVOURITE CH	ON/OFF	ON	
NVM	-	-	

MCL1 & MCL2 CHANNEL SETTING

1). In service mode, After execute select POS 1, setting the following data in E²PROM.

CH-NO	MCL1 (R/C CODE =117)			MCL2 (R/C CODE=169)		
	Fv (MHz)	SOUND SYS	CH-NO	Fv (MHz)	SOUND SYS	CH-NO
1	48.25	AUTO	1	46.25	AUTO	
2	62.25	AUTO	2	64.25	AUTO	
3	77.25	AUTO	3	86.25	AUTO	
4	175.25	AUTO	4	95.25	AUTO	
5	182.25	AUTO	5	138.25	AUTO	
6	183.25	AUTO	6	175.25	AUTO	
7	191.25	AUTO	7	182.25	AUTO	
8	196.25	AUTO	8	189.25	AUTO	
9	210.25	AUTO	9	196.25	AUTO	
10	224.25	AUTO	10	209.25	AUTO	
11	471.25	AUTO	11	216.25	AUTO	
12	487.25	AUTO	12		SKIP OFF FREE	
13	503.25	AUTO	13		SKIP OFF FREE	
14	575.25	AUTO	14		SKIP OFF FREE	
15	599.25	AUTO	15		SKIP OFF FREE	
16	621.25	4.5 M	16		SKIP OFF FREE	
17	639.25	AUTO	17		SKIP OFF FREE	
18	703.25	AUTO	18	527.25	AUTO	
19	735.25	AUTO	19	847.25	AUTO	
20	767.25	AUTO	20	48.25	AUTO	
21	815.25	AUTO	21	175.25	AUTO	
22	855.25	AUTO	22	210.25	AUTO	
23	855.25	AUTO	23	224.25	AUTO	
24	55.25	4.5 M	24	575.25	AUTO	
25	83.25	4.5 M	25	599.25	AUTO	
26	183.25	4.5 M	26	767.25	AUTO	
27	193.25	4.5 M	27	183.25	4.5 M	
28	217.25	4.5 M	28	193.25	4.5 M	
29	471.25	4.5 M	29	112.25	AUTO	
30	477.25	4.5 M	30	168.25	AUTO	
31	693.25	4.5 M	31		SKIP OFF FREE	
32		SKIP OFF FREE	32	294.25	AUTO	
33	112.25	AUTO	33	463.25	AUTO	
34	169.25	AUTO	34	174.95	AUTO	
35		SKIP OFF FREE	35	175.55	AUTO	
36	294.25	AUTO	36		SKIP OFF FREE	
37	463.25	AUTO	37		SKIP OFF FREE	
38		SKIP OFF FREE	38		SKIP OFF FREE	
39	647.25	AUTO	39		SKIP OFF FREE	

SHIPPING SETTING IX3097CEN2

MCL1 (R/C CODE =117)		MCL2 (R/C CODE=169)	
CH-NO	Fv (MHz)	CH-NO	Fv (MHz)
40	663.25	40	SKIP OFF FREE
41	679.25	41	SKIP OFF FREE
42	174.95	42	SKIP OFF FREE
43	175.55	43	SKIP OFF FREE
44	SKIP OFF FREE	44	SKIP OFF FREE
45	SKIP OFF FREE	45	SKIP OFF FREE
↓	SKIP OFF FREE	↓	SKIP OFF FREE
99	SKIP OFF FREE	99	SKIP OFF FREE

NO	ITEMS	SETTING 1	SETTING 2
1	SKIP POS 0	ON	->
2	SKIP POS 1 ~99	OFF	->
3	AFT	ON	->
4	COLOUR SYSTEM	AUTO	->
5	SOUND SYSTEM	BG	BG
6	IGR FORCE FM	OFF	->
7	IGR STEREO	STEREO	->
8	IGR BILINGUAL	MAIN	->
9	NICAM FORCE FM	OFF	->
10	NICAM BILINGUAL	M1	->
11	LAST POWER	ON	->
12	LAST TV/AV	TV	->
13	DIGIT	2 DIGIT	->
14	LANGUAGE	ENGLISH	THAI
15	BLUE BACK	ON	->
16	AV SELECT ON/OFF	OFF	->
17	AV SELECT STD/GAME	STD	->
18	LAST POSITION	1	->
19	LAST FB POSITION	1	->
20	VOLUME	0 (MIN)	->
21	BALANCE	0 (L,R)	->
22	BASS	0	->
23	MIDDLE	0	->
24	TREBLE	0	->
25	SURROUND	OFF	->
26	CONTRAST	63	->
27	COLOUR	31	->
28	BRIGHTNESS	31	->
29	TINT	31	->
30	SHARPNESS	31	->
31	TIMER	CLEAR	->
32	SAVE	OFF	->
33	PICTURE NR	OFF	->
34	INSET TINT	31	->
35	PIP DISPLAY POS	SE	->
36	PIP SIZE	L	->
37	PIP LAST POS	1	->
38	PIP LAST TV/AV	TV	->
39	FREEZE	OFF	->
40	MONORAL BILINGUAL	S 1	->

SERVICE ADJUSTMENT

VCO, AND AGC ADJUSTMENT

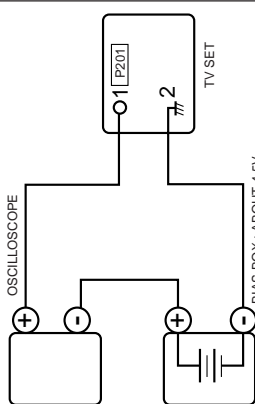
NO	ADJUSTMENT POINT	ADJUSTMENT CONDITION/PROCEDURE	WAVEFORM OR OTHERS
1	VCO ADJUSTMENT (I ² C BUS CONTROL)	<ol style="list-style-type: none"> 1. Receive E-10CH (210.25MHz) "PAL COLOUR BAR" signal. 2. Call "AUTO VCO" in SERVICE mode. If the Channel frequency displays on screen is 210.20MHz, skip (3), (4) & (5) steps. 3. Press FUNCTION button to call "DIRECT FREQ IN". 4. Push "2", "1", "0", "2", "0". 5. Then Press FUNCTION again. 6. Press Volume UP to run "AUTO VCO". Once finishing, "OK" message display on screen. 	Signal Strength: 60 ~ 70 dB
2	AGC ADJUSTMENT (I ² C BUS CONTROL)	<ol style="list-style-type: none"> 7. Receive E-12CH (PAL COLOR BAR) signal. Signal strength : 57 ± 1 dB (75ohm open) 8. Connect the oscilloscope to P201 (Tuner's AGC Terminal) as shown in Figure 1.  <p style="text-align: center;">Figure 1</p>	
		<ol style="list-style-type: none"> 9. Call "AGC" in SERVICE mode. 10. Increase or decrease "AGC" by using Volume so that obtain the highest Voltage. 11. Press Volume slowly in the opposite direction until the voltage drops 0.1V ~ 0.3V lower than the highest level. 12. Change the antenna input signal to 63 ~ 67dBμV, and make sure there is no noise. 13. Turn up the input signal to 90 ~ 95 dBμV to be sure that there is no cross modulation beat. 	



SOUND ADJUSTMENT

NO	ADJUSTMENT POINT	ADJUSTMENT CONDITION/PROCEDURE	WAVEFORM OR OTHERS
1	RF SUB VOLUME (I ² C BUS CONTROL)	<ol style="list-style-type: none"> 1. Receive "PAL COLOUR BAR" signal. Audio signal: 400 Hz, 100% modulated (50kHz dev.) 2. Connect the Oscilloscope to the Audio Out (L or R) terminal. (Terminate with 10k ohm impedance). 3. Call the "RF SUB VOL" in SERVICE mode. 4. Increase or decrease "RF SUB VOL" by using Volume UP/DOWN key, so that the 400Hz sine wave be 1.76Vp-p. Tolerance: 1.76 Vp-p ± 0.10 Vp-p. 	
2	SP SUB VOLUME (I ² C BUS CONTROL)	<ol style="list-style-type: none"> 5. Receive "COLOUR BAR" signal. Audio signal: 400Hz, 100% modulation. (50kHz dev.) 6. Connect Dummy load* to P3304. 7. Connect VTVM's probe to the P3304. (1 R, 2 GND, 3 GND, 4 L, 5 NIL, 6 NIL, 7 NIL, 8 NIL) 8. Call the "SP SUB VOL" in the SERVICE mode. 9. Increase or decrease "SP SUB VOL" by using Volume UP/DOWN key, so that the VTVM should read the value*. 	*Note : Terminated 8 ohm to get 7.75 ± 0.1Vrms. (L Channel)
3	NOISE MUTE CHECKING	<ol style="list-style-type: none"> 10. Receive the 400Hz modulated signal. 11. Turn up the volume control to Maximum and make sure the sound is heard from the speakers. Then put the unit in the no-signal state. 12. Be sure that the sound mute is effective. 13. Finally turn down the volume control to minimum. 	

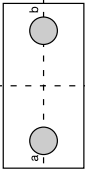
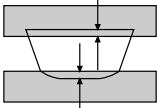
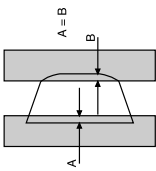
PURITY ADJUSTMENT

NO	ADJUSTMENT POINT	ADJUSTMENT CONDITION/PROCEDURE	WAVEFORM OR OTHERS
1	PURITY ADJ.	<ol style="list-style-type: none"> 1. Receive the GREEN -ONLY signal. Adjust the beam current to ~800µA. 2. Orient the raster rotation to 0 eastward. 3. Degauss the CRT enough with the degaussing coil. 4. Maintain the purity magnet at the zero magnetic field and keep the static convergence roughly adjusted. 5. Observe the points a, b, as shown in Fig.2-1 through the microscope. Adjust the landings to A rank requirement. 6. Tighten up the deflection coil screws. Tightening torque : 108N ± 20N (11Kgf ± 2Kgf) 7. Make sure the CRT corners landing meet the A rank requirements. If not, stick the magnet sheet to correct it. <p>Note: This adjustment must be done after warming up the unit for 30 minutes or longer with a beam current over 1000µA.</p> <p>Note: Set the service mode by service switch (S 1006) then press factory process R/C RGB key to change to green only.</p> <p>* For the following colour press colour key to change.</p> <pre> graph TD A[GREEN ONLY] --> B[BLUE ONLY] B --> C[RED ONLY] C --> D[COLOUR ABSORBED] D --> A </pre> <p>Text Key "R.G.Cy" Key can be directly use to change to other colours screen.</p>	 <p>Figure 2-1</p>  <p>Figure 2-2 Rank A (On the right of CRT)</p>  <p>Figure 2-3 Rank A (On the left of CRT)</p>

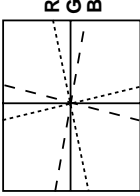
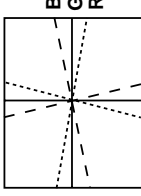
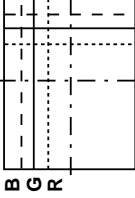
CONVERGENCE ADJUSTMENT

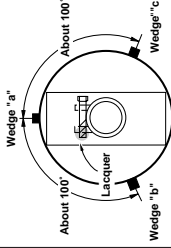
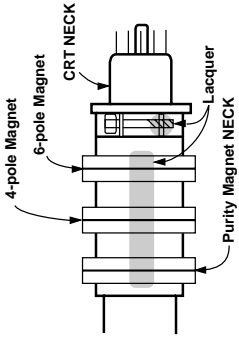
NO	ADJUSTMENT POINT	ADJUSTMENT CONDITION/PROCEDURE	WAVEFORM OR OTHERS
1	CONVERGENCE ADJ. (To be done after the purity adjustment.)	<ol style="list-style-type: none"> 1. Receive the "CROSSHATCH PATTERN" signal. 2. Using the remote controller, call NORMAL mode. (Static convergence) 1. Turn the 4 - pole magnet to a proper opening angle in order to superpose the blue and red colours. 2. Turn the 6 - pole magnet to a proper opening angle in order to superpose the green colour over the blue and red colours. <p>(Dynamic convergence)</p> <ol style="list-style-type: none"> 1. Adjust the convergence on the fringes of the screen in the following steps. <ol style="list-style-type: none"> a) Fig. a : Drive the wedge at point "a" and swing the deflection coil upward. b) Fig. b : Drive the wedge at point "a" and "b" and swing the deflection coil downward. c) Fig. c : Drive the "c" wedge deeper and swing the deflection coil rightward. d) Fig. d : Drive the "b" wedge deeper and swing the deflection coil leftward. 2. Fix all the wedges on the CRT and apply glass tape over them. 3. Apply lacquer to the deflection yoke lock screw, magnet unit (purity 4 - pole, 6 - pole magnets) and magnet unit lock screw. <p>Finally received the Red - only and Blue - only signals to make sure there is no other colours on the screen.</p>	 <p>Figure a</p>  <p>Figure b</p>  <p>Figure c</p>  <p>Figure d</p>  <p>Figure 3</p>  <p>Figure 4</p>

CUT OFF , WHITE BALANCE, SUB - BRIGHT, & FOCUS ADJUSTMENT.

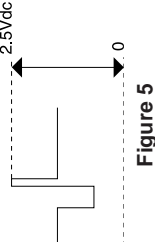
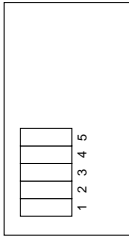
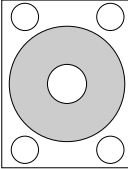
NO	ADJUSTMENT POINT	ADJUSTMENT CONDITION/PROCEDURE	WAVEFORM OR OTHERS
1	CRT Cut - OFF ADJ. (fC BUS CONTROL)	<ol style="list-style-type: none"> Switch TV to VIDEO MODE, Blue Back: OFF, Without Video Signal. Connect the oscilloscope to TP851. (Use a 10:1 probe) Range: 500mV/div Sweep Time: 5ms/div Press "DC" mode Using the remote controller, call NORMAL mode. Adjust Screen VR so that the tip of signal reach 2.5Vdc \pm 0.1Vdc. 	<p>* Before adjustment , make sure that this adjustment with the initial bus data "White Point (G)" & "White Point (B)" are 32.</p>  <p>Figure 5</p>
2	White Balance ADJ. (fC BUS CONTROL)	<ol style="list-style-type: none"> Receive the MONOSCOPE PATTERN signal. Call the "BKGD" in SERVICE mode. Adjust "White Point (G)", "White Point (B)" data to have a colour temperature of 12300k (White) Note. 	<p>Note : White Point (G) UP " 2 " KEY DOWN " 5 " KEY White Point (B) UP " 3 " KEY DOWN " 6 " KEY As the above data can be UP / DOWN.</p> <p>*12300k x=272 y=275 (Minolta Colour Analyzer CA-100)</p>
3	SUB- BRIGHT ADJ. (fC BUS CONTROL)	<ol style="list-style-type: none"> Receive the "CROSSHATCH PATTERN" Signal. Call the "SUB BR1" in SERVICE mode. Adjust the "SUB-BR1" bus data, so that the No. 2 line inside the window area will disappear. <p>Note: Before starting this adjustment, warm up the unit for 30 minutes or longer at a beam current of 1200 ~ 1300μA.</p>	 <p>Figure 6</p>
4	BEAM CURRENT CHECK	<ol style="list-style-type: none"> Receive the "MONOSCOPE PATTERN" Signal. Press P-NORMAL key. Connect the DC Milliammeter between TP601 (-) and TP602 (+). (Full Scale: 3.0 mA Range). Beam current Must be 1200 \pm 100μA. 	
5	FOCUS ADJ.	<ol style="list-style-type: none"> Receive the "MONOSCOPE PATTERN" signal. Using the remote control, call NORMAL mode. Adjust the FOCUS control so that the shaded area of screen be in optimal focus. 	 <p>Figure 7</p>

HORIZONTAL, VERTICAL, DEFLECTION LOOP ADJUSTMENT.

NO	ADJUSTMENT POINT	ADJUSTMENT CONDITION/PROCEDURE	WAVEFORM OR OTHERS
1	V-SLOPE ADJ. (fC BUS CONTROL)	<ol style="list-style-type: none"> Receive the "MONOSCOPE PATTERN" signal. Call the "V-SLOPE" in SERVICE mode. Increase or decrease "V-SLOPE" by using Volume key so that the center line of picture matches with the edge of blanking line. 	SPEC: \pm 1 SCANNING LINE
2	V-SHIFT 50 (fC BUS CONTROL)	<ol style="list-style-type: none"> Receive the 50Hz "MONOSCOPE PATTERN" signal. Call the "V-SIFT 50" in SERVICE mode. Increase or decrease the "V-SIFT 50" by using Volume UP/DOWN key to adjust or align the screen center with the CRT's geometrical center. 	SPEC: \pm 2mm
	V-SHIFT 60 (fC BUS CONTROL)	<ol style="list-style-type: none"> Receive the 60 Hz "MONOSCOPE PATTERN" signal. Call the "V-SIFT 60" in SERVICE mode. Increase or decrease the "V-SIFT 60" by using Volume UP/DOWN key to adjust or align the screen center with the CRT's geometrical center. 	
3	V-AMP (fC BUS CONTROL)	<ol style="list-style-type: none"> Receive the "MONOSCOPE PATTERN" signal. Call the "V-AMP" in SERVICE mode. Increase or decrease the "V-AMP" by using the volume UP/DOWN key to adjust the Vertical size until it is 8.5% overscan. 	OVER SCAN: 8.5% \pm 1.5 %
4	H-SHIFT 50 (fC BUS CONTROL)	<ol style="list-style-type: none"> Receive the 50Hz "MONOSCOPE PATTERN" signal. Call the "H-SIFT 50" IN SERVICE MODE. Increase or decrease the "H-SIFT 50" by using the Volume UP/DOWN key to adjust or align the left, and right sides of screen are equal overscan size. 	SPEC: \pm 2mm
	H-SHIFT 60 (fC BUS CONTROL)	<ol style="list-style-type: none"> Receive the 60Hz "MONOSCOPE PATTERN" signal. Call the "H-SIFT 60" IN SERVICE MODE. Increase or decrease the "H-SIFT 60" by using the Volume UP/DOWN key to adjust or align the left and right sides of screen are equal overscan size. 	

HORIZONTAL, VERTICAL, DEFLECTION LOOP ADJUSTMENT.

NO	ADJUSTMENT POINT	ADJUSTMENT CONDITION/PROCEDURE	WAVEFORM OR OTHERS
5	S-COR (I ² C BUS CONTROL)	<ol style="list-style-type: none"> 1. Receive the "CROSSHATCH PATTERN" signal. 2. Call the "S-COR" IN SERVICE mode. 3. Increase or decrease the "S-COR" by using the Volume UP/DOWN key to get the best LINEARITY. 4. Adjustment with S-COR: OVERALL VERTICAL LINEARITY. 5. Readjust the "V-AMP" to make the overscan 8.5%. Readjust or align "V-SIFT" to match the screen center with the CRT's geometrical center. 	V-LINEARITY: ± 5% Max

Y DELAY ADJUSTMENT

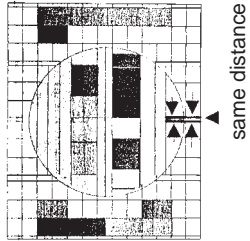
NO	ADJUSTMENT POINT	ADJUSTMENT CONDITION/PROCEDURE	WAVEFORM OR OTHERS
1	Y DELAY (I ² C DATA)	<ol style="list-style-type: none"> (1) Receive the PAL B/G PHILIPS pattern signal. (2) Switch on service mode then press channel up/down key to select Y DELAY mode. (3) Press volume up/down key to select a suitable number so that luminance delay similar to color delay, shown as fig. 10. (4) The Y DELAY data is between 6~8. (5) Switch off the service mode. 	 <p style="text-align: center;">same distance Figure 10</p>

PAL CHROMA ADJUSTMENT

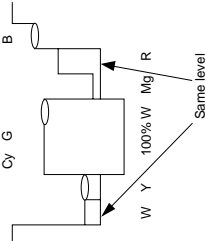
NO	ADJUSTMENT POINT	ADJUSTMENT CONDITION/PROCEDURE	WAVEFORM OR OTHERS
1	SUB COLOUR ADJ. (I ² C BUS CONTROL)	<ol style="list-style-type: none"> 1. Receive the "PAL Color Bar" signal. 2. Using remote controller, call NORMAL mode. 3. Connect the oscilloscope to TP852 (Red cathode). Range: 20 V/Div (Using 10:1 Probe) Sweep: 20 μ sec/Div 4. Using the R/C call "SUB COL" adjustment mode. Adj SUB-COL bus data, so that the 75% White & Red portions of PAL Color Bar be at the same level. 5. Clear the adjustment mode. 	 <p style="text-align: center;">Figure 8</p>

NTSC CHROMA ADJUSTMENT

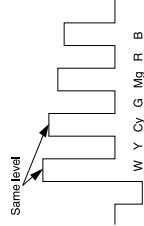
NO	ADJUSTMENT POINT	ADJUSTMENT CONDITION/PROCEDURE	WAVEFORM OR OTHERS
1	AV-TINT (I ² C BUS CONTROL)	<ol style="list-style-type: none"> 1. Receive the AV NTSC 3.58 Colour Bar signal. 2. Connect the oscilloscope to TP853. Range: 500mV/Div Sweep time: 20 μ sec/Div 3. Set the "SUB-TIN" mode at service mode. Adjust the "SUB TIN" bus data so that the FIRST AND SECOND portions of the colour Bar are SAME level shown in Figure 9. 	 <p style="text-align: center;">Figure 9 Note: Be sure that AV TINT set to 00 at SERVICE mode.</p>

OPTION ADJUSTMENT

NO	ADJUSTMENT POINT	ADJUSTMENT CONDITION/PROCEDURE	WAVEFORM OR OTHERS
1	SECAM SETTING	<ol style="list-style-type: none"> 1. Call "SECAM" in SERVICE mode. 2. Switch the "SECAM" by using the Volume UP/DOWN key to "OFF". 	
2	M SETTING	<ol style="list-style-type: none"> 1. Call "M" in SERVICE mode. 2. Switch the "M" by using the Volume UP/DOWN key to "OFF". 	
3	S-SYS SETTING	<ol style="list-style-type: none"> 1. Call "S-SYS" in SERVICE mode. 2. Switch the "S-SYS" by using the Volume UP/DOWN key to "OFF". 	
4	C-SYS SETTING	<ol style="list-style-type: none"> 1. Call "C-SYS" in SERVICE mode. 2. Switch the "C-SYS" by using the Volume UP/DOWN key to "OFF". 	

CHECKING OPERATION (VIDEO & AUDIO)

NO	CHECKING POINT	SETTING CONDITION	WAVEFORM OR OTHERS
1	CONTRAST	<ol style="list-style-type: none"> 1. Receive the "MONOSCOPE PATTERN" signal. 2. Press the CH UP/DOWN key for PICTURE control setting with R/C, select the CONTRAST. 3. Increase or decrease the CONTRAST by using the VOLUME UP / DOWN key. 4. Check whether the CONTRAST is OK or not. 	
2	COLOUR	<ol style="list-style-type: none"> 1. Receive the "COLOUR BAR PATTERN" signal. 2. Press the CH UP / DOWN key for PICTURE control setting with the R/C, select the COLOUR. 3. Increase or decrease the COLOUR by using the VOLUME UP / DOWN key. 4. Check whether the COLOUR is OK or not. 	
3	BRIGHTNESS	<ol style="list-style-type: none"> 1. Receive the "MONOSCOPE PATTERN" signal. 2. Press the CH UP / DOWN key for PICTURE control setting with the R/C, select the BRIGHTNESS . 3. Increase or decrease the BRIGHTNESS by using the VOLUME UP / DOWN key. 4. Check whether the BRIGHTNESS is OK or not. 	
4	SHARPNESS	<ol style="list-style-type: none"> 1. Receive the "MONOSCOPE PATTERN" signal. 2. Press the CH UP / DOWN key for PICTURE control setting with the R/C, select the SHARPNESS. 3. Increase or decrease the SHARPNESS by using the VOLUME UP / DOWN key. 4. Check whether the SHARPNESS is OK or not. 	
5	WHITE TEMP	<ol style="list-style-type: none"> 1. Receive the "MONOSCOPE PATTERN" signal. 2. Press the CH UP / DOWN key for PICTURE control setting with the R/C, select WHITE TEMP. 3. Increase or decrease the WHITE TEMP by using the VOLUME UP / DOWN key. 4. Check whether the WHITE TEMP is OK or not. 	

AV INPUT/OUTPUT CHECKING

NO	ADJUSTMENT POINT	ADJUSTMENT CONDITION/PROCEDURE	WAVEFORM OR OTHERS
1	VIDEO & AUDIO OUTPUT CHECKING	<ol style="list-style-type: none"> 1. Receive the "PAL COLOUR BAR" signal (100% White Color Bar Sound 400 Hz 100% Modulation) 2. Terminate the Video output with a 75 ohm impedance. Make sure the output is as specified (1.0 Vp-p ± 3 dB) 3. Terminate the Audio output with a 10 Kohm impedance. Make sure the O/P is as specified (1.76 Vp-p ± 3 dB). 	
2	VIDEO & AUDIO INPUT CHECKING	<ol style="list-style-type: none"> 1. Using the TV/AV key on the remote controller, make sure that the modes change in order of TV, AV1, AV2 & TV again and that the video & audio output are according to the input terminal for each mode. 	
3	AUTO SELECT	<ol style="list-style-type: none"> 1. Connect Video signal to FRONT AV (AV2). 2. Make sure Channel switch from other channel to AV2 automatically. 	

PROTECTOR OPERATION CHECKING

NO	ADJUSTMENT POINT	ADJUSTMENT CONDITION/PROCEDURE	WAVEFORM OR OTHERS
1	BEAM PROTECTOR	<ol style="list-style-type: none"> 1. Receive the "MONOSCOPE PATTERN" signal. 2. Set CONTRAST MAX. 3. Set BRIGHT MAX. 4. While the R or B or G Cathode short to ground, make sure the protector ON and switch to standby mode. 	

PROTECTOR OPERATION CHECKING

NO	ADJUSTMENT POINT	ADJUSTMENT CONDITION/PROCEDURE	WAVEFORM OR OTHERS
2	H, V PROTECTOR	<ol style="list-style-type: none"> 1. Receive the "MONOSCOPE PATTERN" signal. 2. Connect output of Bias Box to D601 cathode (D608). 3. Set voltage of Bias Box to 20V and make sure the protector is work. 	
3	OTHER PROTECTOR	<ol style="list-style-type: none"> 1. Once finish rectified Electrolytic Capacitor short testing in + B line, check all possible damaged components on +B line. 	

CHECKING OPERATION (VIDEO & AUDIO)

NO	CHECKING POINT	SETTING CONDITION	WAVEFORM OR OTHERS
6	NORMAL	<ol style="list-style-type: none"> 1. Receive the "COLOUR BAR PATTERN" signal. 2. Press NORMAL key to set the picture condition to normal . When the NORMAL key is pressed, all the initial picture control settings will be preset to normal setting as listed below: Contrast: MAX. Colour: CENTER Brightness: CENTER Tint: CENTER Sharpness: CENTER 	If nothing is display mean contrast, colour, bright, tint, sharpness are all in normal setting.
7	CH COLOUR DISPLAY	All Ch (1~99) will have an OSD display of the channel number in green colour under AFT ON condition.	
8	BASS	<ol style="list-style-type: none"> 1. Receive the MUSIC SOUND SIGNAL. 2. Press the CH UP / DOWN key for SOUND control setting with the R/C, select the BASS. 3. Increase or decrease the BASS by using the VOLUME UP / DOWN key. 4. Check whether the BASS (low frequency) is OK or not. 	
9	MIDDLE	<ol style="list-style-type: none"> 1. Receive the MUSIC SOUND SIGNAL. 2. Press the CH UP / DOWN key for SOUND control setting with the R/C, select the MIDDLE. 3. Increase or decrease the MIDDLE by using the VOLUME UP / DOWN key. 4. Check whether the MIDDLE (MIDDLE frequency) is OK or not. 	
10	TREBLE	<ol style="list-style-type: none"> 1. Receive the MUSIC SOUND SIGNAL. 2. Press the CH UP / DOWN key for SOUND control setting with the R/C, select the TREBLE. 3. Increase or decrease the TREBLE by using the VOLUME UP / DOWN key. 4. Check whether the TREBLE (HIGH frequency) is OK or not. 	
11	BALANCE	<ol style="list-style-type: none"> 1. Receive the MUSIC SOUND SIGNAL. 2. Press the CH UP / DOWN key for SOUND control setting with the R/C, select the BALANCE. 3. Increase or decrease the left or right speaker BALANCE by using the VOLUME UP / DOWN key. 4. Check whether the BALANCE of left and right speakers is OK or not. 	
12	NORMAL	<ol style="list-style-type: none"> 1. Receive the MUSIC SOUND SIGNAL. 2. Press NORMAL key to set the sound condition to normal . When the NORMAL key is pressed, all the initial sound control settings will be preset to normal setting as listed below: BASS: CENTER MIDDLE: CENTER TREBLE: CENTER BALANCE: CENTER 	If nothing is display mean contrast, colour, bright, tint, sharpness are all in normal setting.
13	SURROUND	<ol style="list-style-type: none"> 1. Receive the MUSIC SOUND SIGNAL. 2. Press the CH UP / DOWN key for SURROUND control setting with the R/C. 3. Press Volume Up to switch Surround Mode as follows; MOVIE/DISCO/POP/ROCK/CLASSIC/SPORTS/SIMULATED/OFF. 4. Make sure each mode is working properly. 	
14	COLOUR SYSTEM	<ol style="list-style-type: none"> 1. Receive the "PAL COLOUR BAR PATTERN" signal. Press the SYSTEM key to set the COLOUR SYSTEM MODE to AUTO mode. Check whether the colour of the PAL Colour Bar signal is OK or not. 2. Receive the "NTSC 4.43 COLOUR BAR" signal. Press the SYSTEM key to set the COLOUR SYSTEM mode to AUTO mode. Check whether the colour of the N4.43 Colour Bar signal is OK or not. 3. Receive the "NTSC 3.58 COLOUR BAR" signal. Press the SYSTEM key to set the COLOUR SYSTEM mode to AUTO mode. Check whether the colour of the N3.58 Colour Bar signal is OK or not. 	
15	FUNCTION	<ol style="list-style-type: none"> 1. Press FUNCTION key to select each mode as follows, SAVE/ AV SELECT/NR/ BLUE BACK/OSD. 2. Press Volume Up to switch each mode, make sure each mode is working properly. 	
16	NOISE MUTE CHECKING	<ol style="list-style-type: none"> 1. Receive "PAL COLOUR BAR" signal. 2. Turn up the volume control to maximum, make sure the sound is heard from the speakers. Then put the unit in no signal state. 3. Be sure that the sound mute is effective. 4. Finally turn down the volume of CTV to minimum. 	
17	BILINGUAL	<ol style="list-style-type: none"> 1. Receive "DUAL SOUND" signal. 2. Press CH UP/DOWN key for SOUND control setting with the R/C, select BILINGUAL. 3. Press VOLUME UP/DOWN to select SOUND 1 & SOUND 2. 4. Check whether SOUND 1 & SOUND 2 are okay separately or not. 	

TROUBLESHOOTING

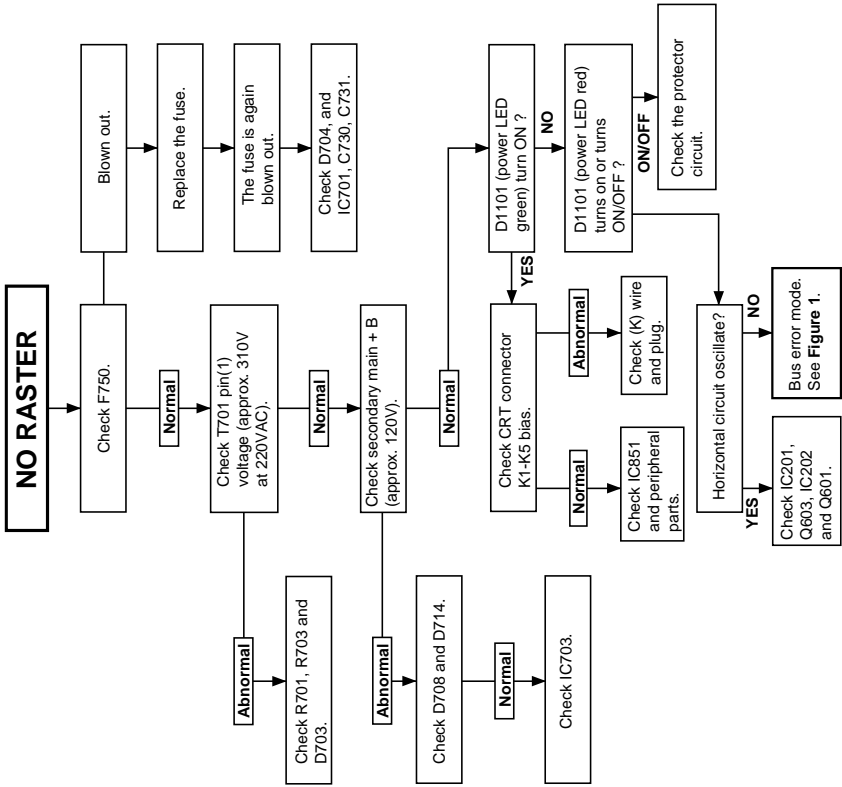

If bus error happen, the LED RED (pin (30) of IC1001 low) indicator starts flashing and the power is turned off. The power key is still effective.

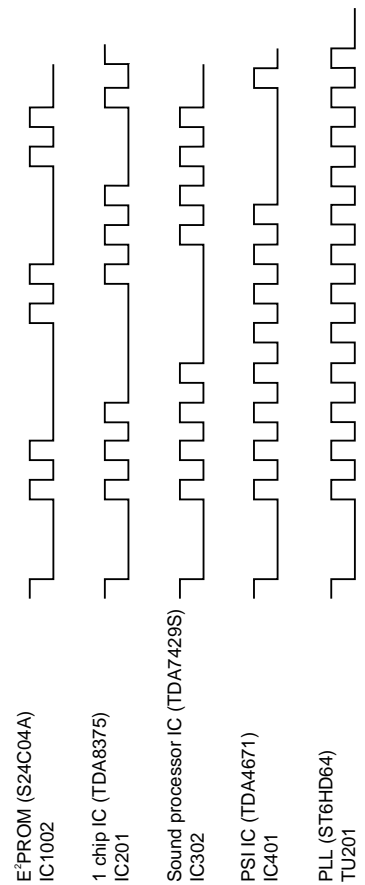
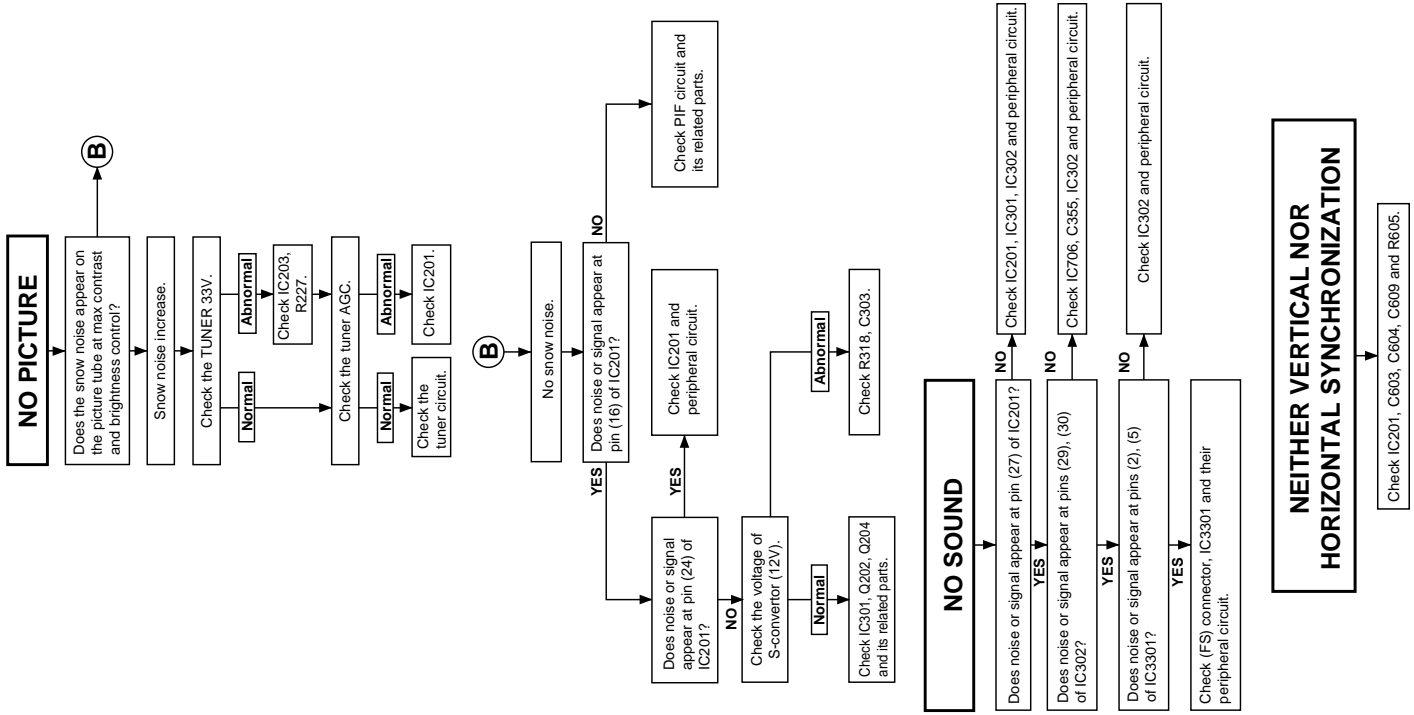
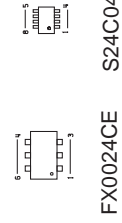
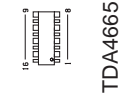
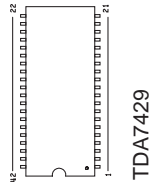
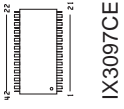
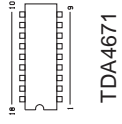
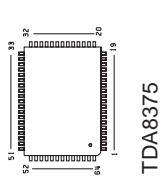

Figure 1



SOLID STATE DEVICE BASE DIAGRAM

TOP VIEW



SIDE VIEW

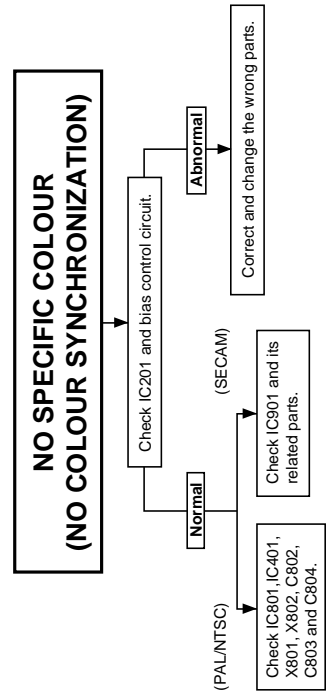
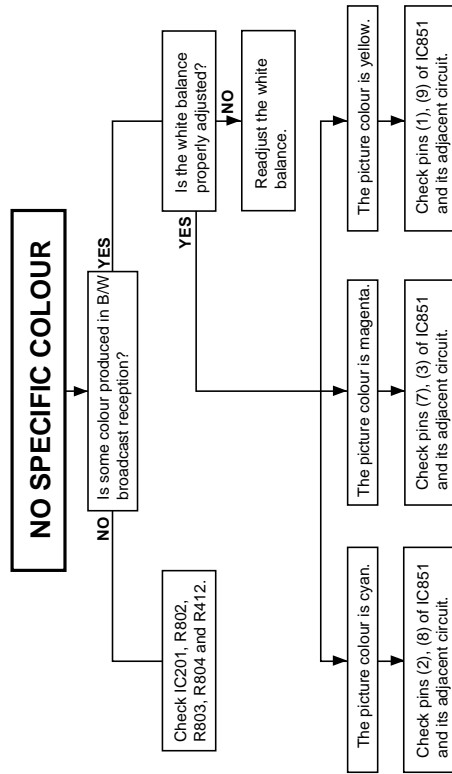
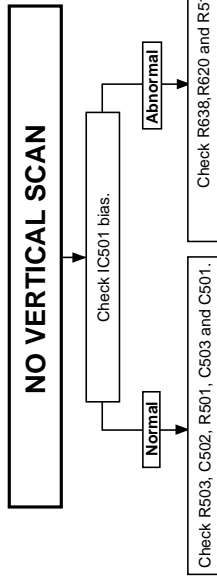
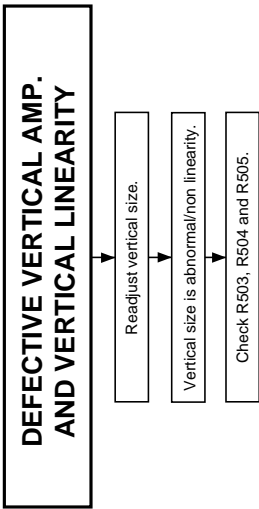
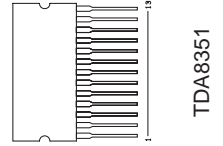
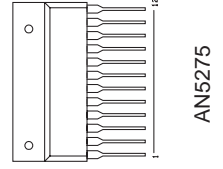
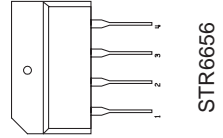
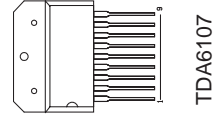
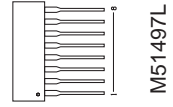
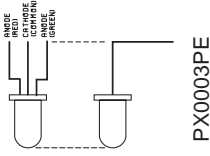
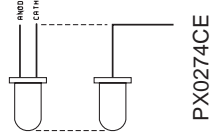
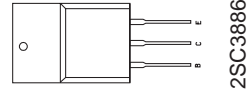
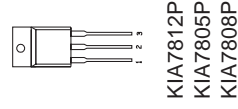
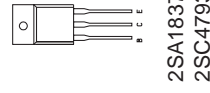
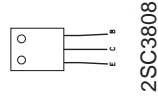
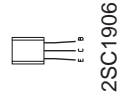
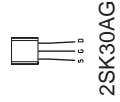
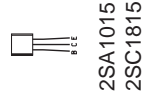

WAVEFORMS

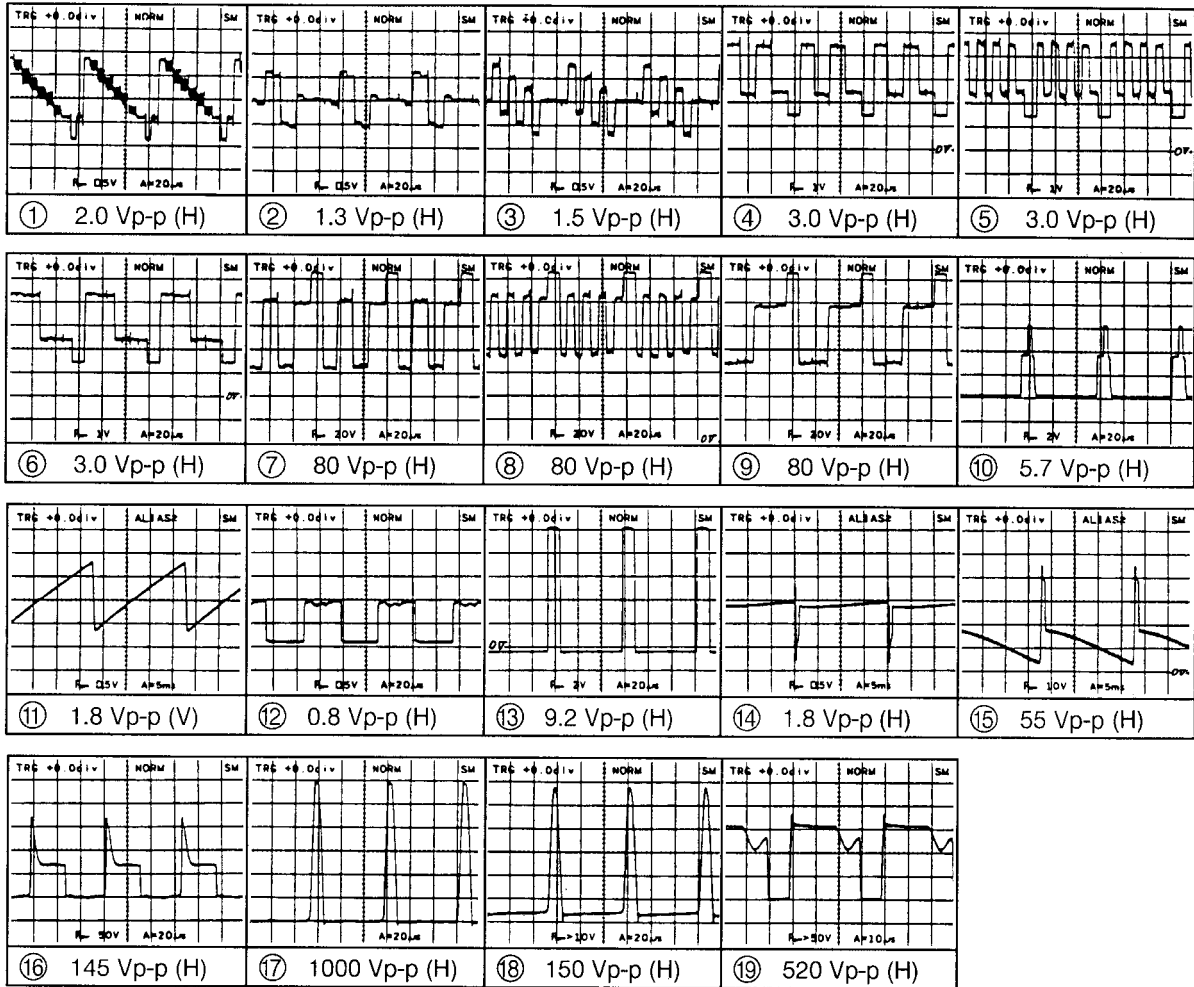

DESCRIPTION OF SCHEMATIC DIAGRAM

SAFETY NOTES:

1. DISCONNECT THE AC PLUG FROM THE AC OUTLET BEFORE REPLACING PARTS.
2. SEMICONDUCTOR HEAT SINKS SHOULD BE REGARDED AS POTENTIAL SHOCK HAZARDS WHEN THE CHASSIS IS OPERATING.

IMPORTANT SAFETY NOTICE:

PARTS MARKED WITH "▲" () ARE IMPORTANT FOR MAINTAINING THE SAFETY OF THE SET. BE SURE TO REPLACE THESE PARTS WITH SPECIFIED ONES FOR MAINTAINING THE SAFETY AND PERFORMANCE OF THE SET.

SERVICE PRECAUTION:

THE AREA ENCLOSED BY THIS LINE () IS DIRECTLY CONNECTED WITH AC MAINS VOLTAGE. WHEN SERVICING THE AREA, CONNECT AN ISOLATING TRANSFORMER BETWEEN TV RECEIVER AND AC LINE TO ELIMINATE HAZARD OF ELECTRIC SHOCK.

NOTES:

1. The unit of resistance "ohm" is omitted (K: 1000 ohms M = Meg ohm).
2. All resistors are 1/8 watt, unless otherwise noted.
3. All capacitors μF , unless otherwise noted. ($P = \mu\mu F$)

VOLTAGE MEASUREMENT CONDITIONS:

1. Voltage in parenthesis measured with no Signal.
2. Voltages without parenthesis measured with 3mV B & W or colour-Signal.
3. All the voltages in each point are measured with VTVM.

WAVEFORM MEASUREMENT CONDITIONS:

1. Colour bar generator signal of 1.0V peak to peak applied pin (24) of IC201.
2. Approximately 4.0 V AGC bias.

BLOCK DIAGRAM MAIN 1 UNIT BLOCK DIAGRAM

PWB-A (MA

DUNTK9482WET9

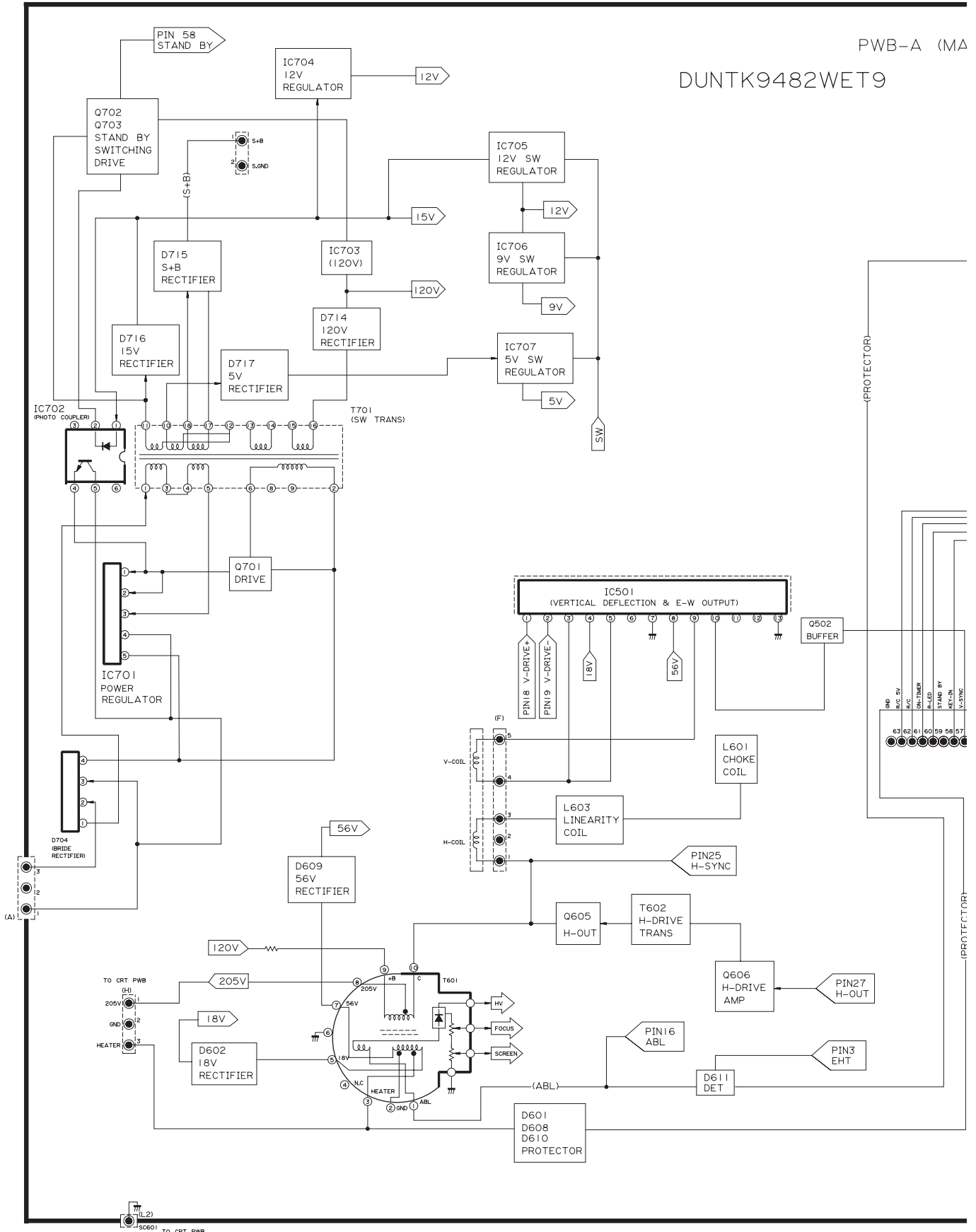

PWB-A (MAIN UNIT)

WET9

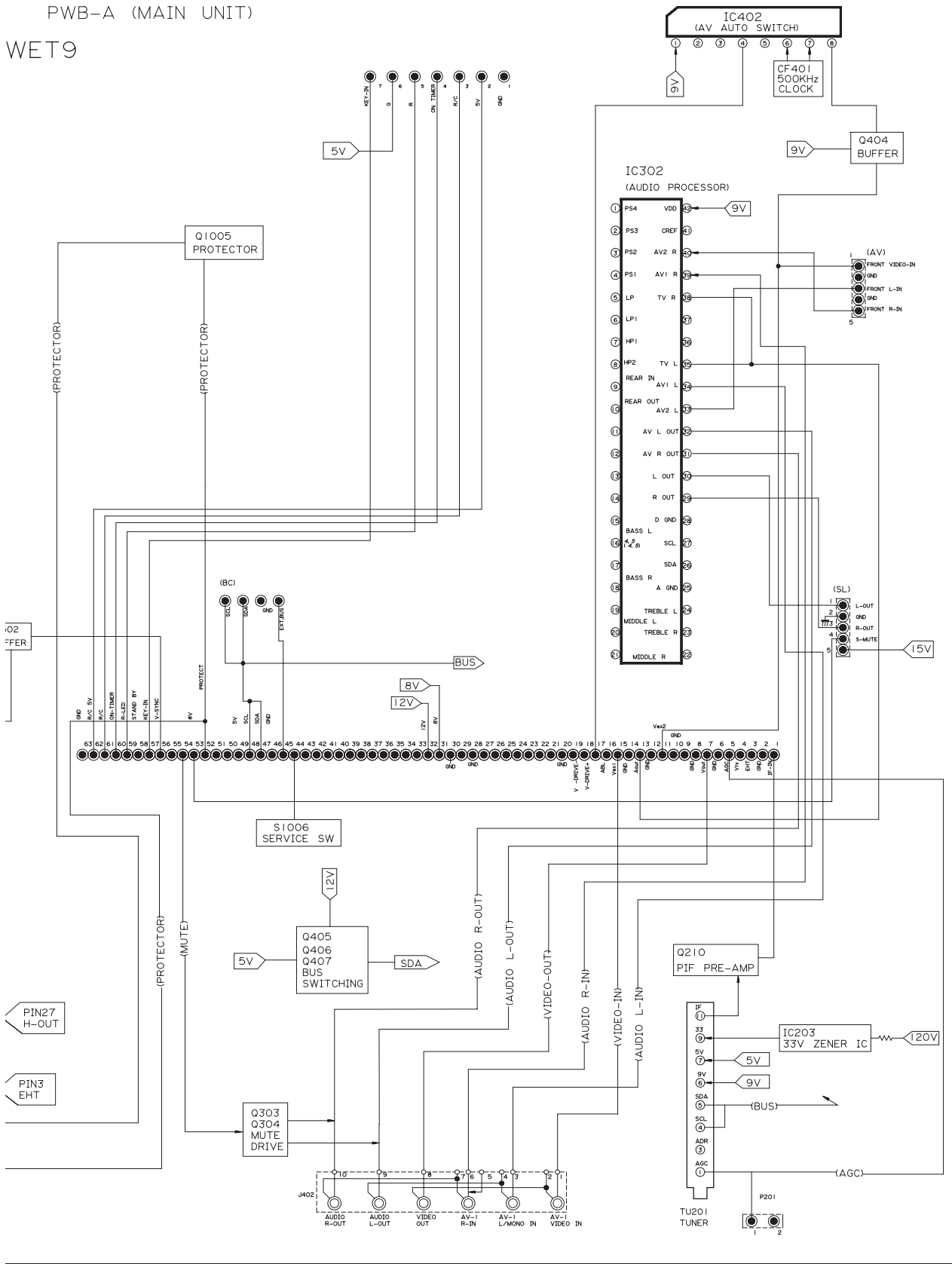

MAIN 2 UNIT BLOCK DIAGRAM

MAIN2
PWB-B (MAIN2 UNIT)
RUNTK003PEZZ
(A3TX003SS)

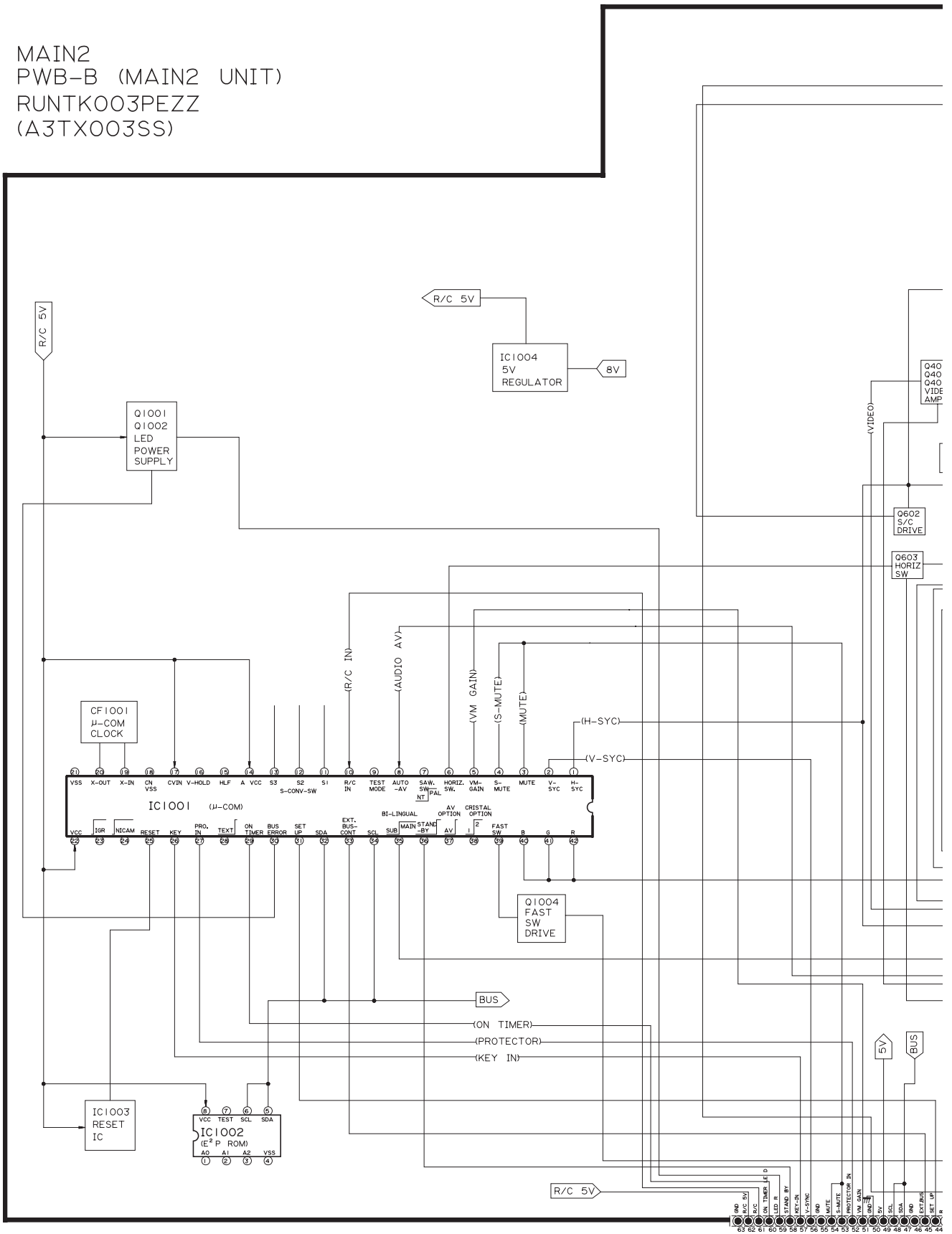

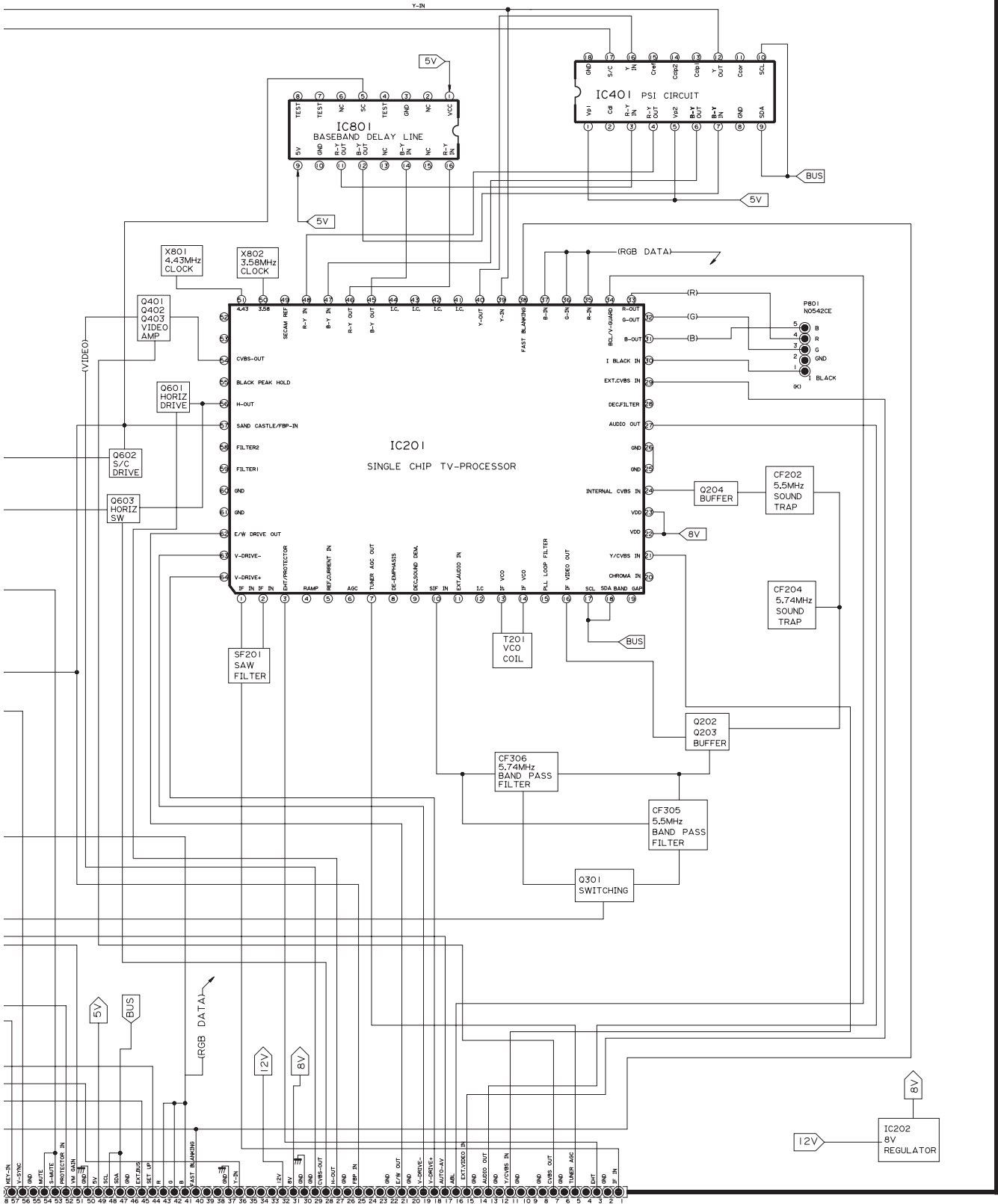

CRT/FRONT/S-OUT UNIT BLOCK DIAGRAM

PWB-C (CRT UNIT)
DUNTK9486WET4

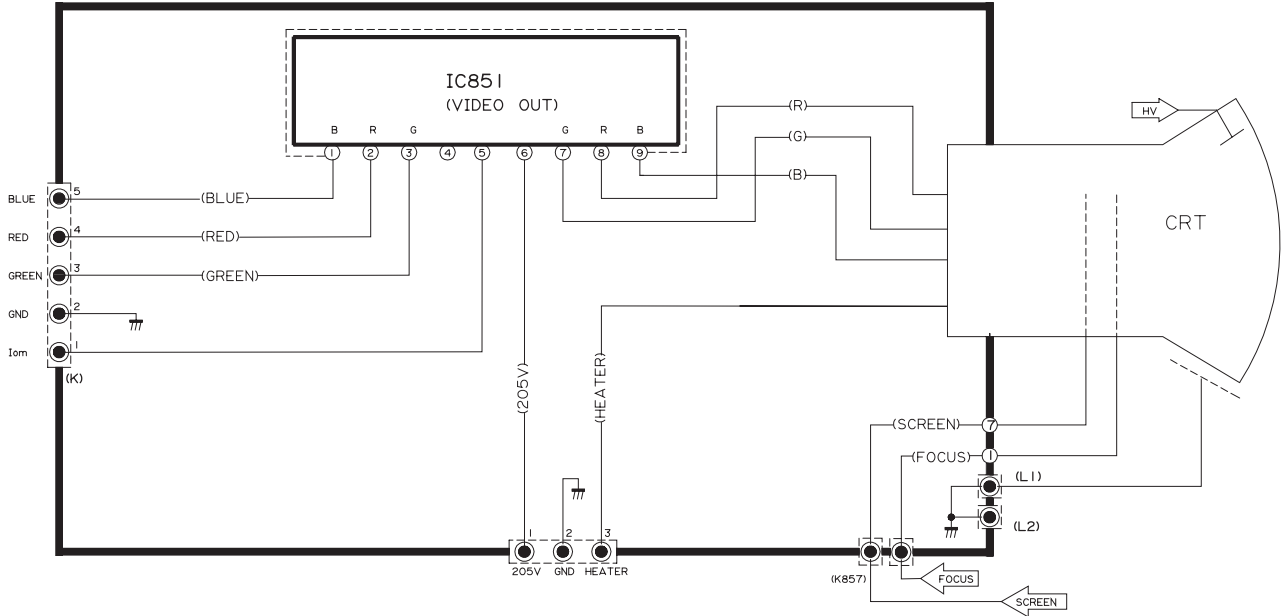

PWB-D (FRONT UNIT)
DUNTK9809WETO

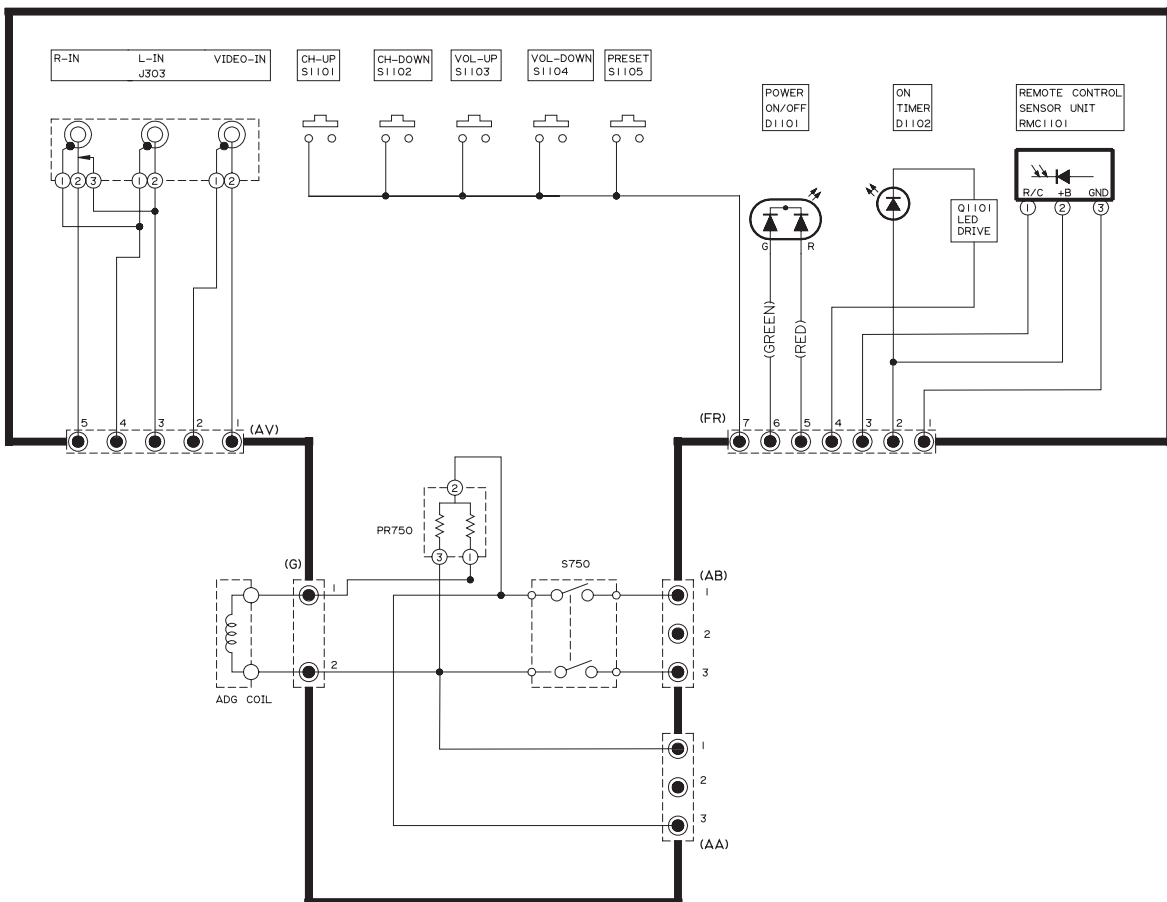

PWB-E (S-OUT UNIT)
DUNTK9481WET3

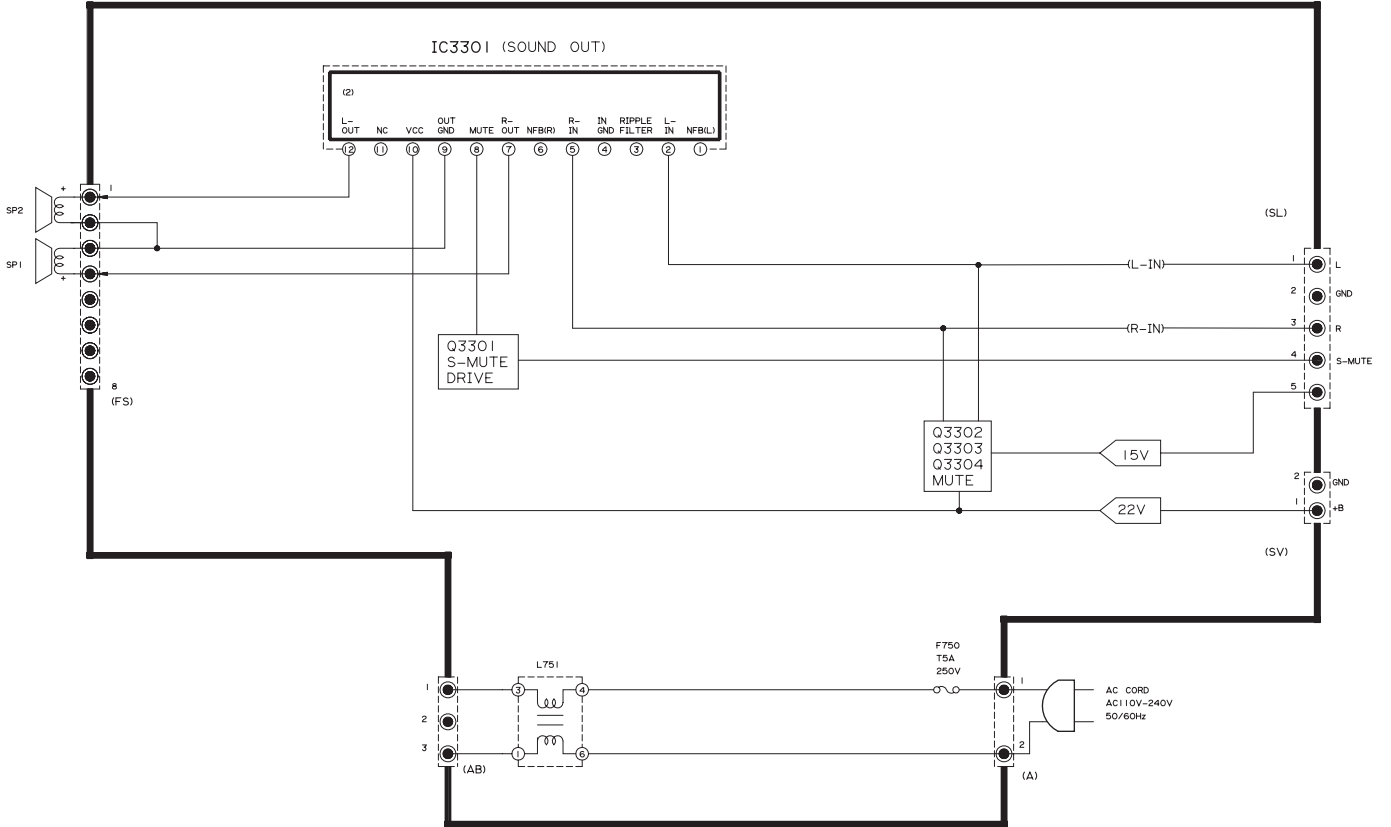

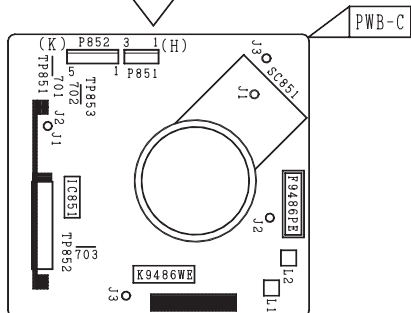
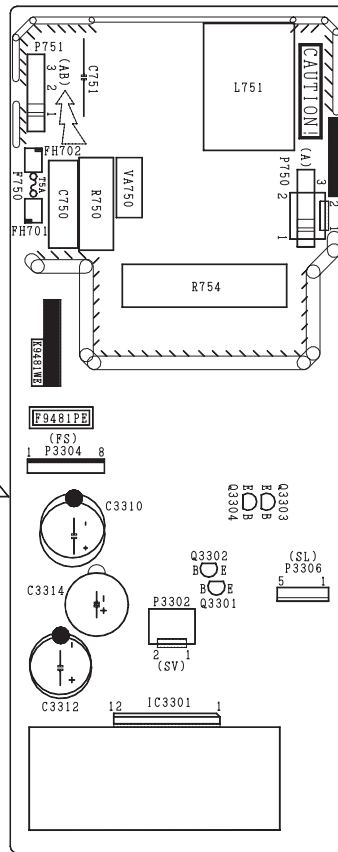
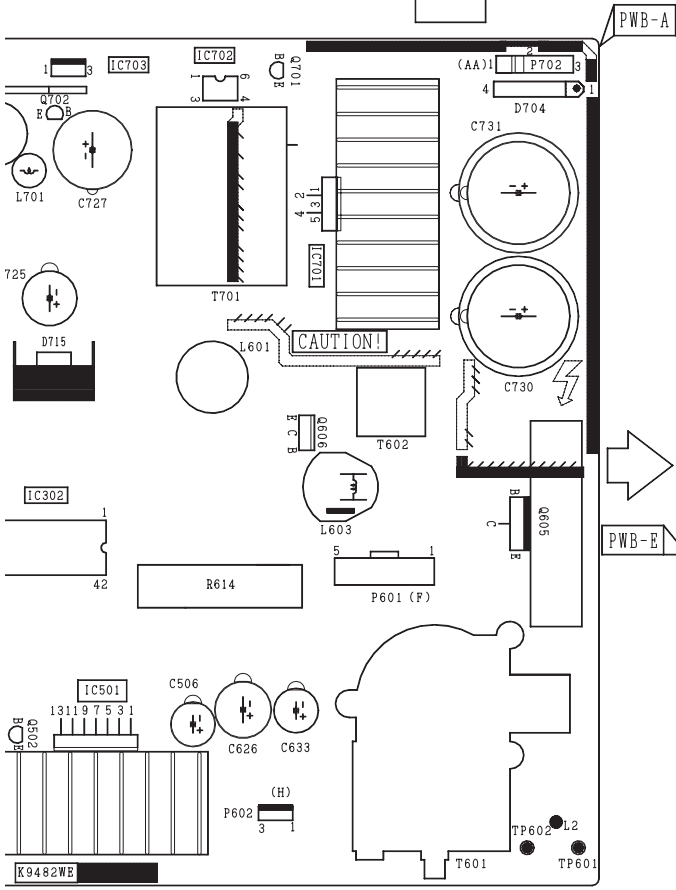
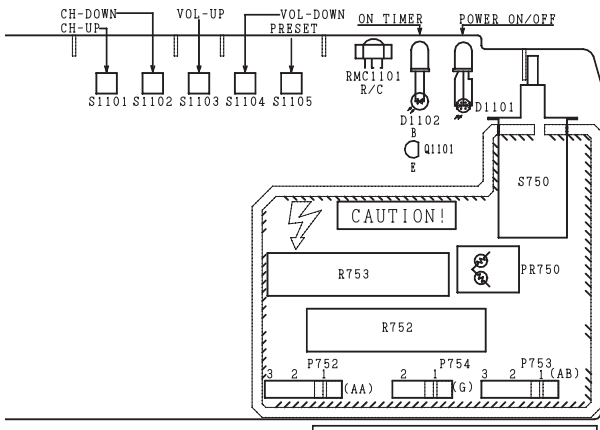

7	8	9	10	11	12	13
---	---	---	----	----	----	----

SCHEMATIC DIAGRAM MAIN 1 UNIT SCHEMATIC DIAGRAM

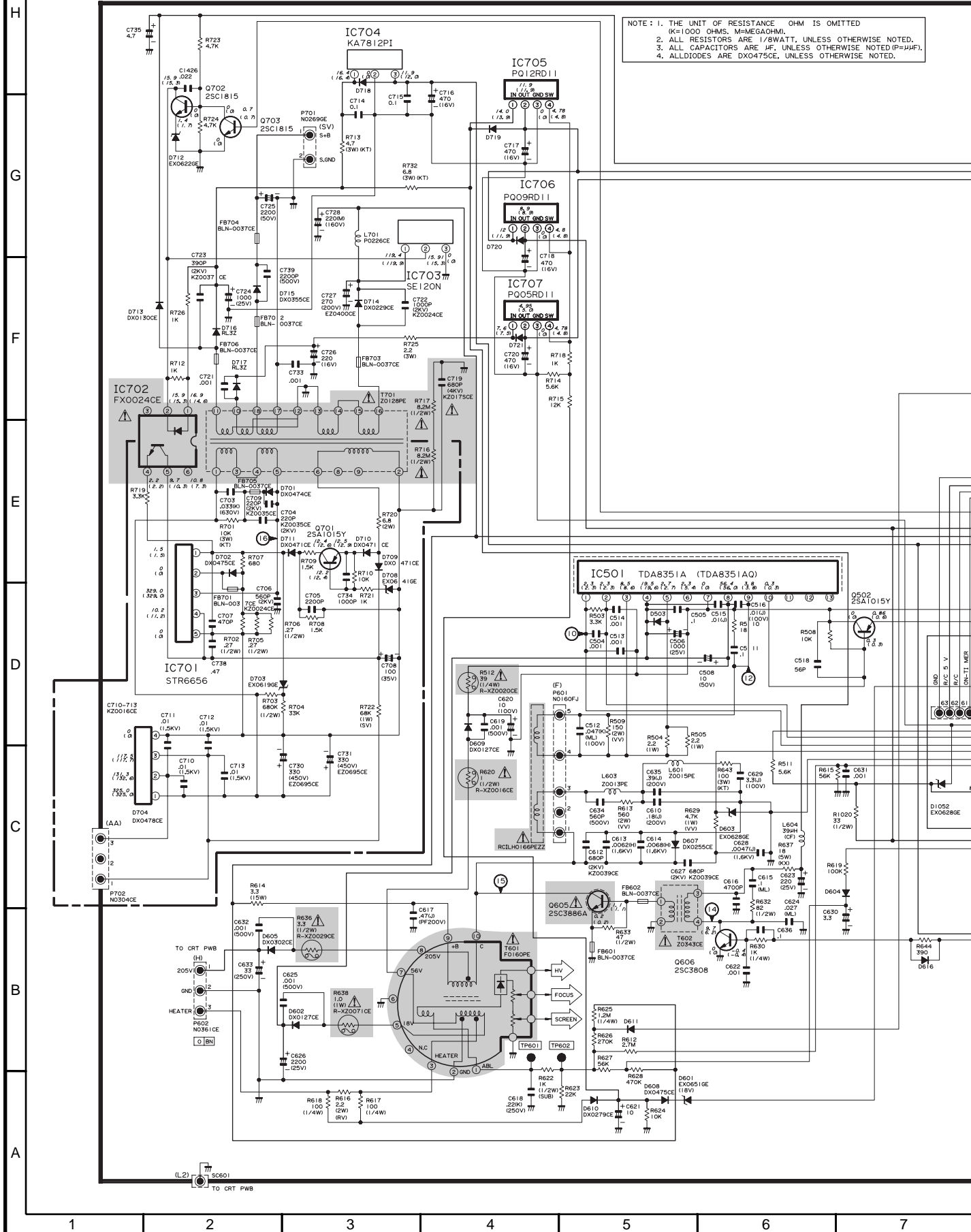

NOTE: 1. THE UNIT OF RESISTANCE OHM IS OMITTED (K=1000 OHMS, M=MEGAOHM).
2. ALL RESISTORS ARE 1/8WATT, UNLESS OTHERWISE NOTED.
3. ALL CAPACITORS ARE .UF, UNLESS OTHERWISE NOTED (P=PF).
4. ALL DIODES ARE DX0475CE, UNLESS OTHERWISE NOTED.

NOT FITTED
OTHERWISE NOTED.
RWISE NOTED (P=HJF).
ERWISE NOTED.

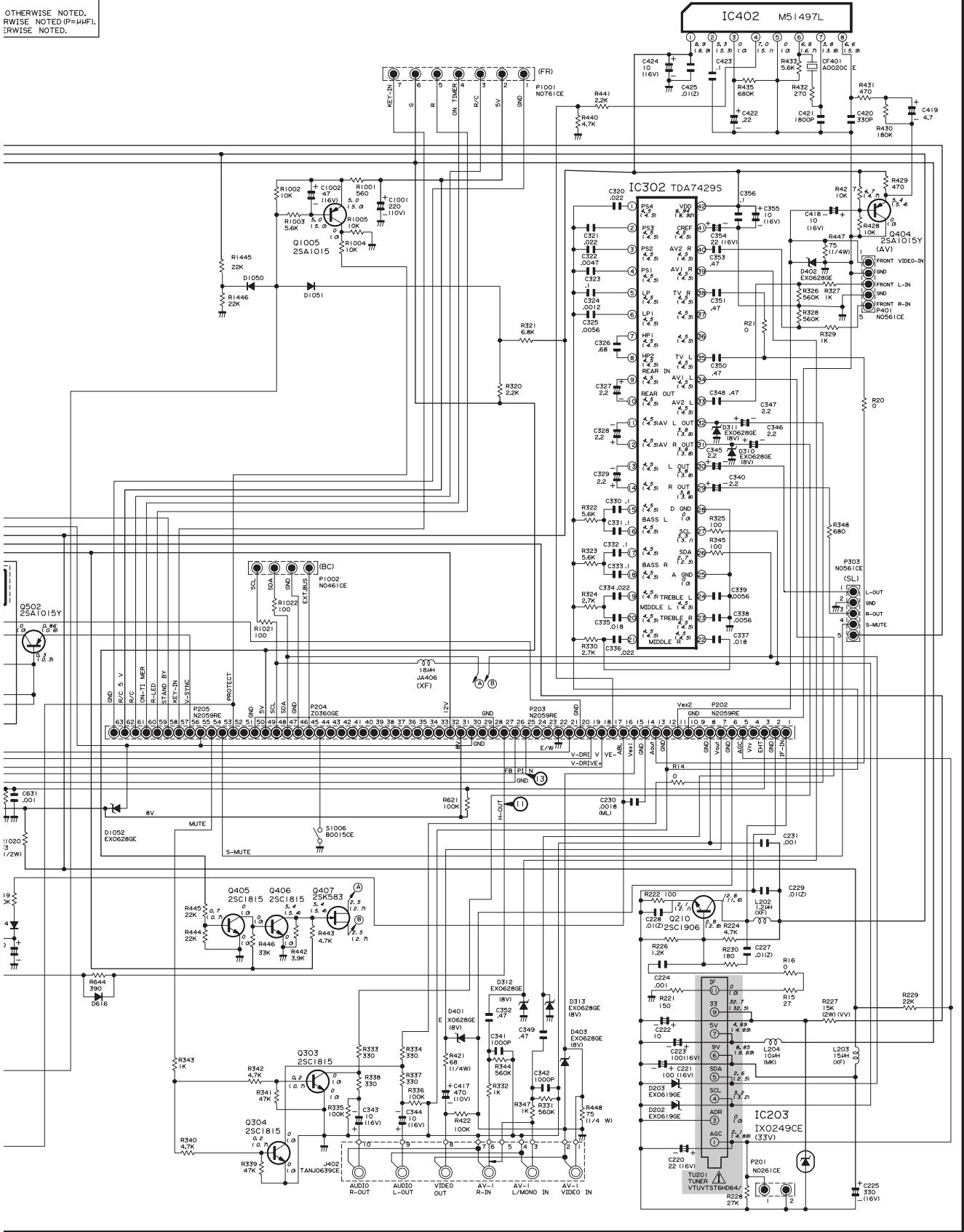

7	8	9	10	11	12	13
---	---	---	----	----	----	----

MAIN 2 UNIT SCHEMATIC DIAGRAM

- NOTE 1. THE UNIT OF RESISTANCE OHM IS OMITTED.
 (K=1000 OHMS, M=MEGA OHM).
 2. ALL RESISTORS ARE 1/8WATT, UNLESS OTHERWISE NOTED.
 3. ALL CAPACITORS ARE MF, UNLESS OTHERWISE NOTED (P=µMF).
 4. ALL DIODES ARE DX0475CE, UNLESS OTHERWISE NOTED.
 5. ALL TRANSISTORS ARE 25C2412KG, UNLESS OTHERWISE NOTED.

PWB-B (MAIN2 UNIT)
 RUNTK003PEZZ
 (A3TX003SS)

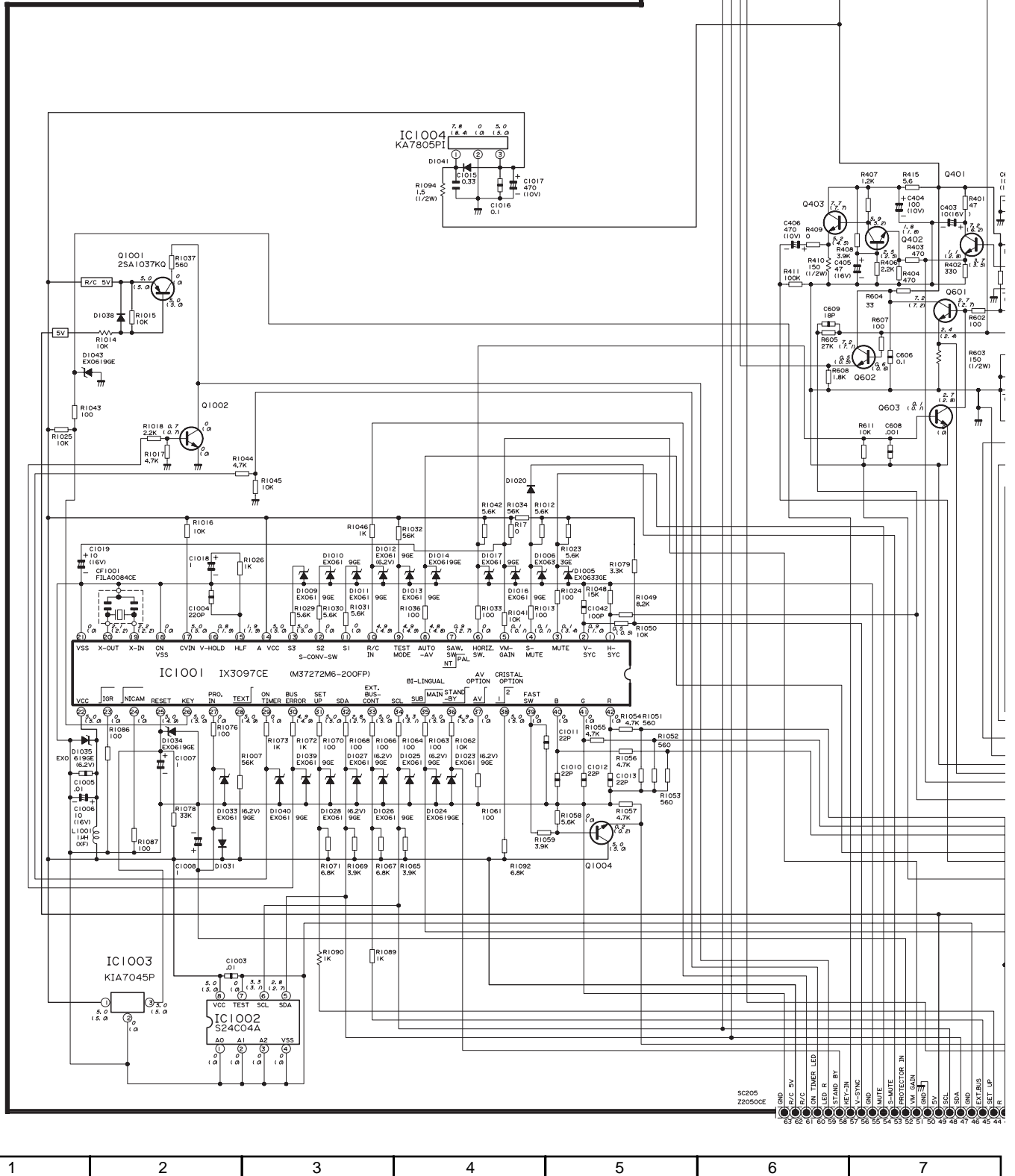

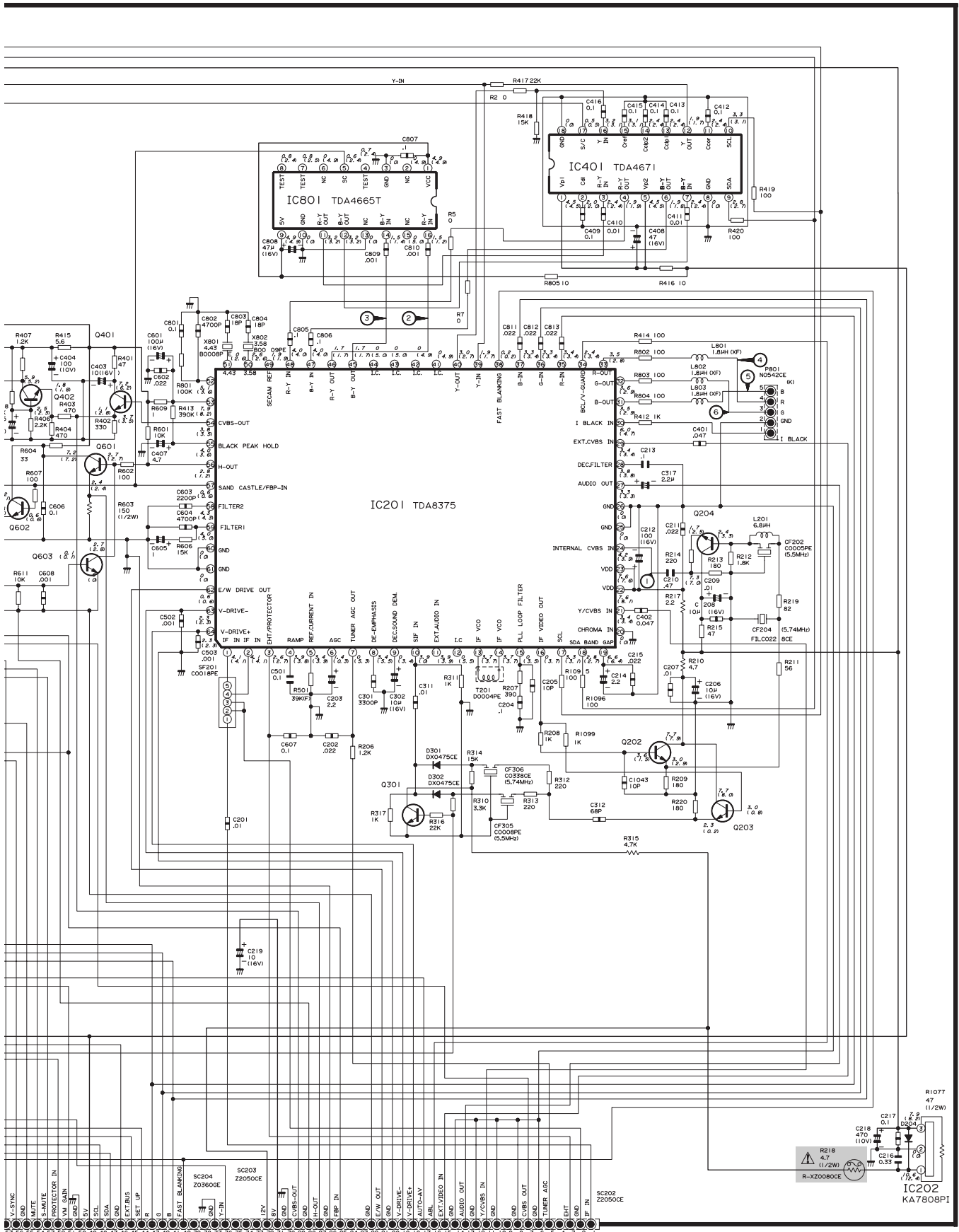

7	8	9	10	11	12	13
---	---	---	----	----	----	----

TUNER SCHEMATIC DIAGRAM

VTUVTST6HD64/

NOTE: The parts here shown are supplied as an assembly but not independently.

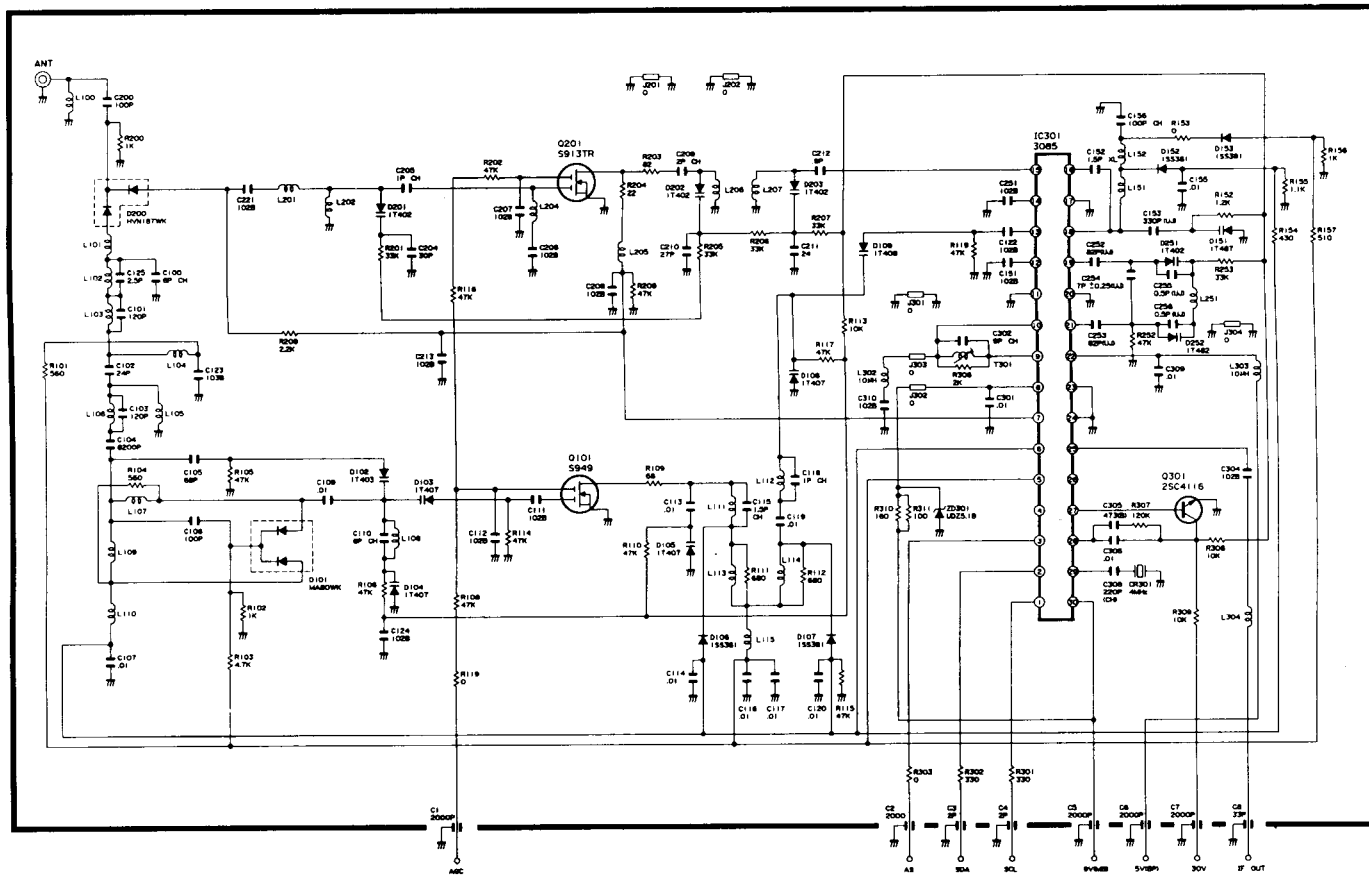

REMOTE CONTROL UNIT SCHEMATIC DIAGRAM

NOTE: The parts here shown are supplied as an assembly but not independently.

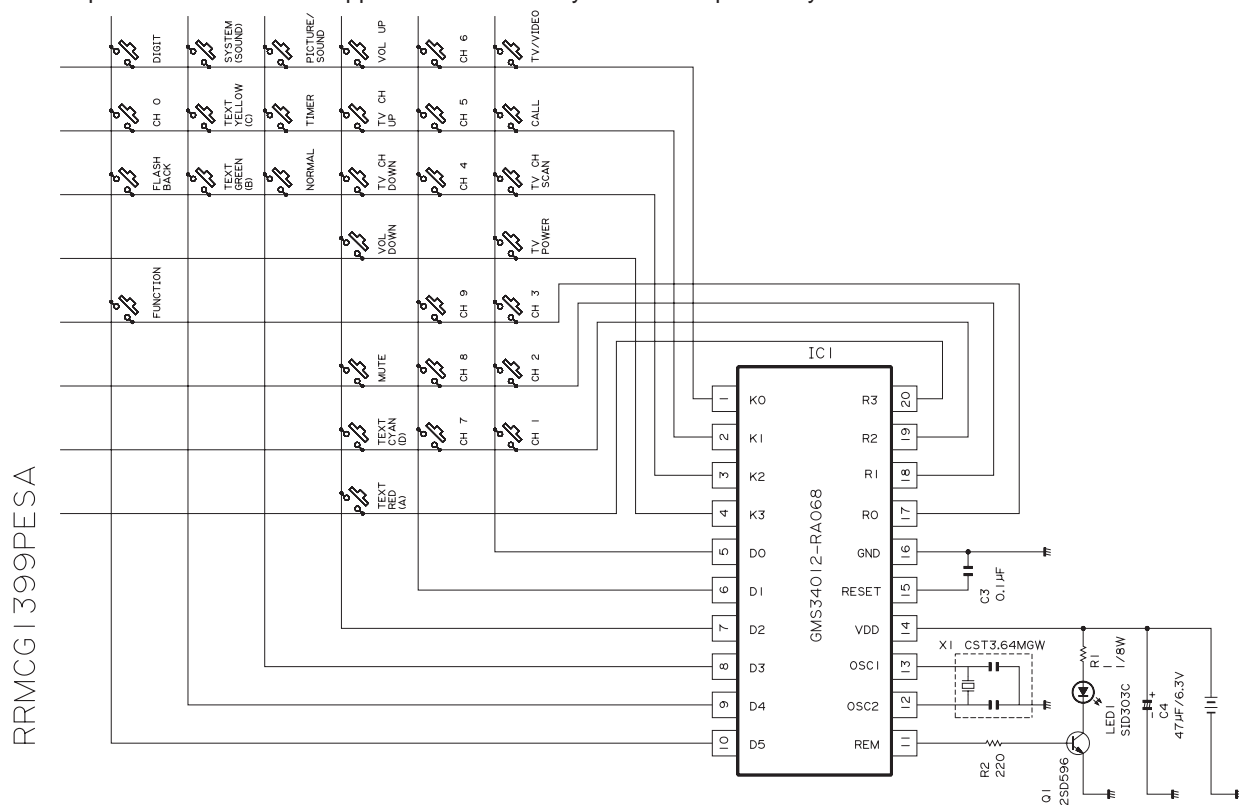

RRMCG1399PESA

PRINTED WIRING BOARD ASSEMBLIES MAIN 1 UNIT

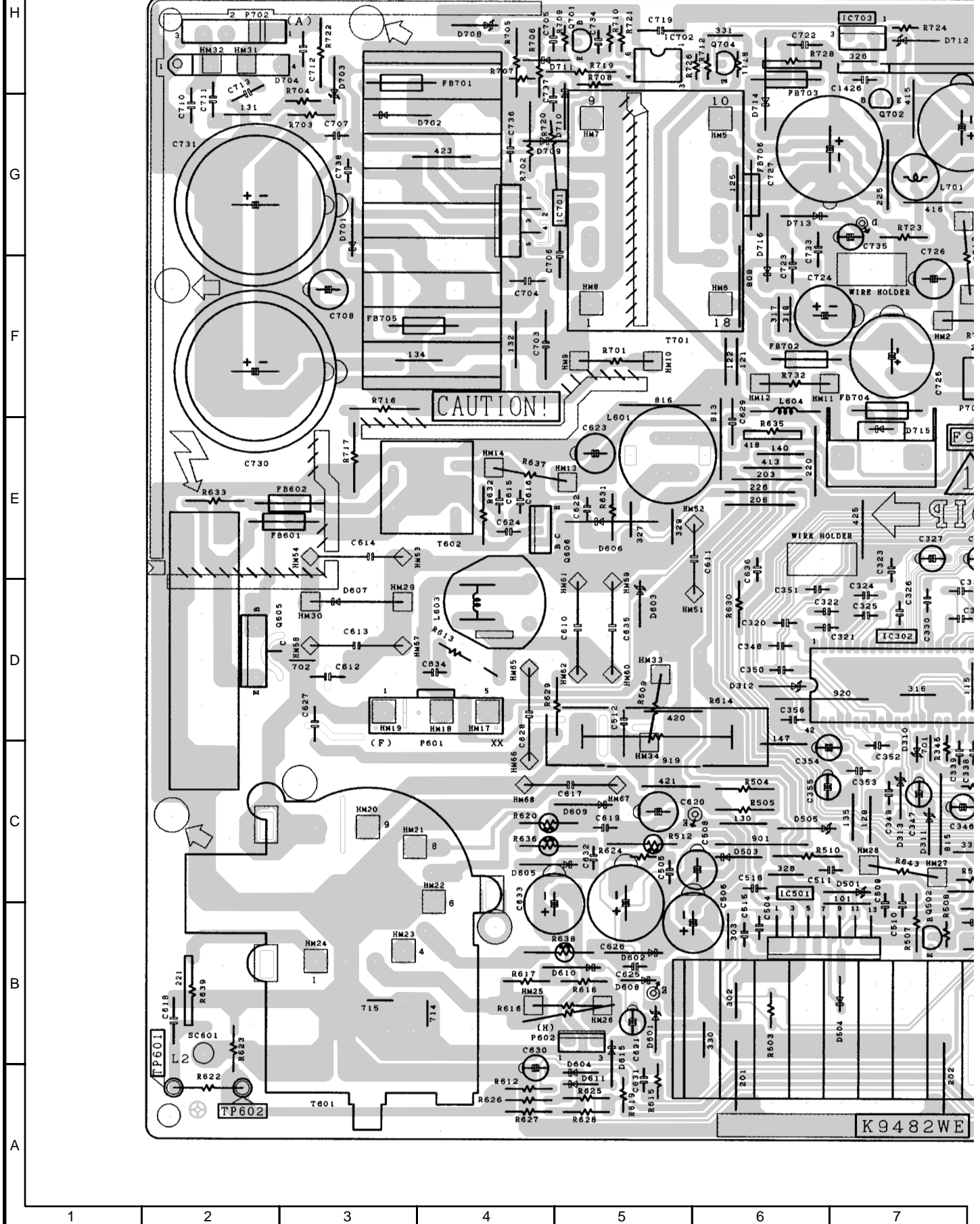

FRONT UNIT

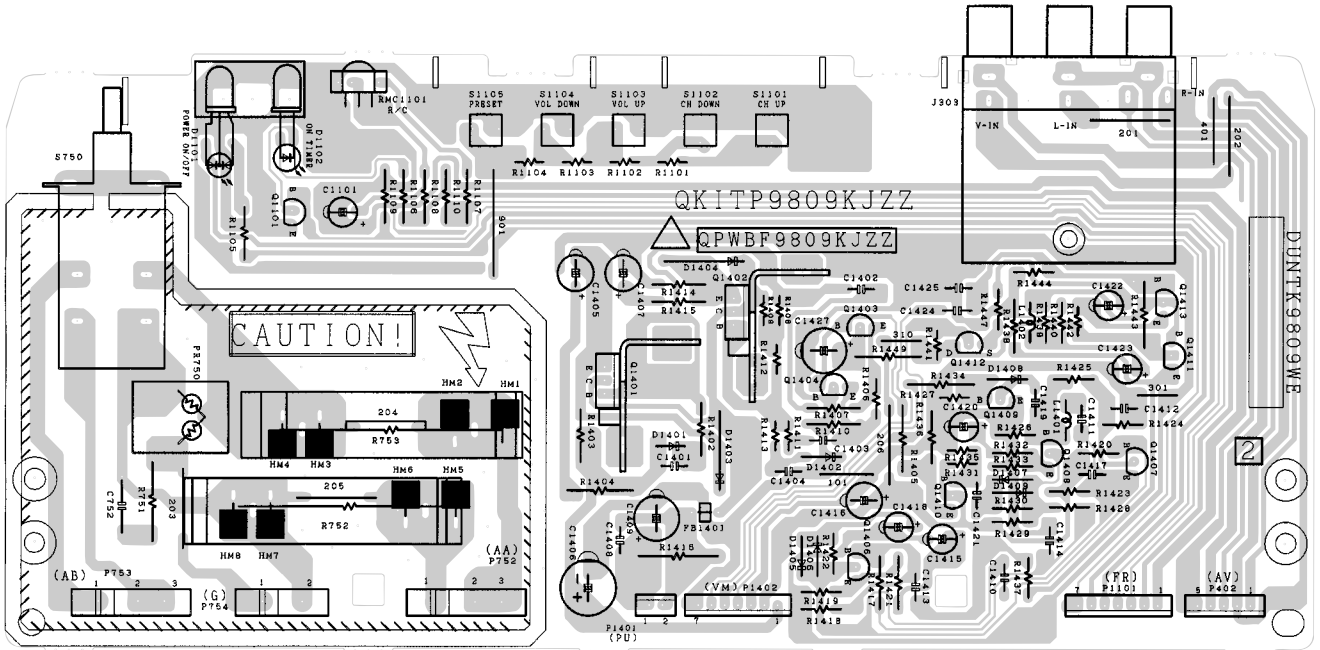

S-OUT UNIT

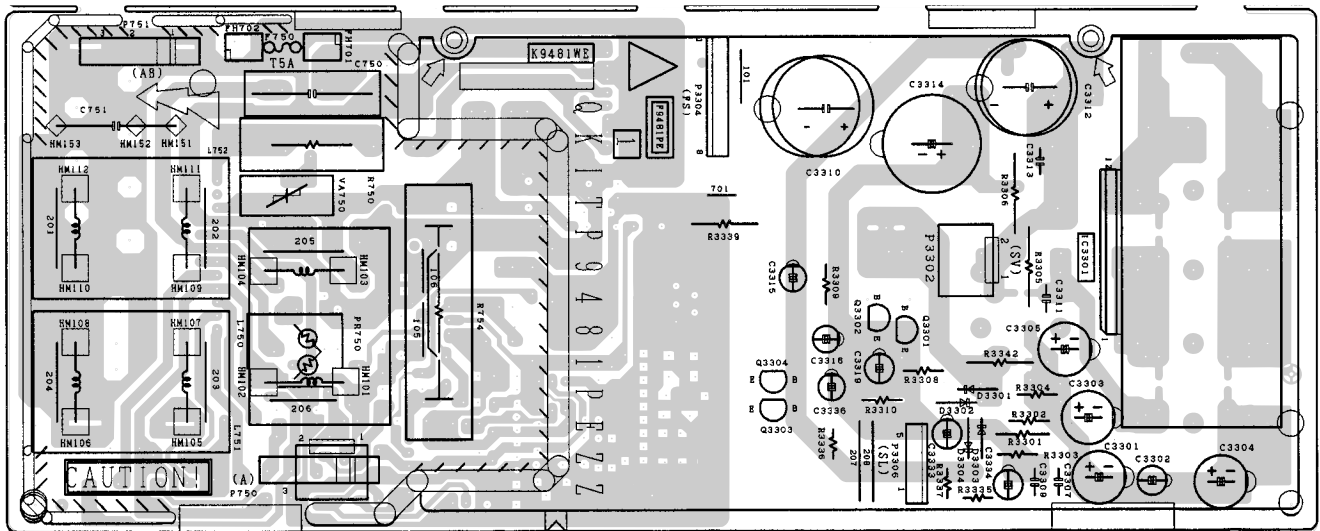

7	8	9	10	11	12
---	---	---	----	----	----

PARTS LIST

PARTS REPLACEMENT

Replacement parts which have these special safety characteristics are identified this manual; electrical components having such features are identified by "△" in the Replacement Parts Lists. The use a substitute replacement part which does not have the same safety characteristics as the factory recommended replacement parts shown in this service manual may create shock, fire or other hazards.

" HOW TO ORDER REPLACEMENT PARTS "

To have your order filled promptly and correctly, please furnish the following informations.

- | | |
|------------------------|-----------------------|
| 1. MODEL NUMBER | 2. REF. NO. |
| 3. PART NO. | 4. DESCRIPTION |

MARK★: SAFETY PARTS-DELIVERY SECTION.

Ref. No.	Part No.	★	Description	Code
----------	----------	---	-------------	------

PICTURE TUBE

△ V1	VB59LGV10X/1E	R	Picture Tube	CR
△	RCiLG0044PEZZ	R	Degaussing Coil	AX
△	RCiLH0166PEZZ	R	Deflection Yoke	BQ
	PMAGF3003CEZZ	R	P-Magnet	AK
	PMAGG3002CEZZ	R	Magnet, x2	AC
	PSPAG0003PEZZ	R	Wedge(Gum), x3	AD
	QEARC2501KJZZ		Ground Strap	
	LHLDW0003PEKZ	R	ADG Coil Holder, x4	AB

PRINTED WIRING BOARD ASSEMBLIES (NOT REPLACEMENT ITEM)

DUNTK9809WET0	-	Front Unit	—
DUNTK9481WET3	-	S-Out Unit	—
DUNTK9482WET9	-	Main 1 Unit	—
DUNTK9483WEW4	-	Main 2 Unit	—
DUNTK9486WET4	-	CRT Unit	—

DUNTK9809WET0 FRONT UNIT

TRANSISTOR

Q1101	VS2SC1815GW-1	R	2SC1815GW	AB
-------	---------------	---	-----------	----

DIODES

D1101	RH-PX0003PEZZ	R	LED, Power ON/OFF	AF
D1102	RH-PX0274CEZZ	R	LED, ON Timer	AC
PR750	RMPTP0084CEZZ	R	Packaged Circuit	AM

CAPACITORS

C752	VCFYSB2EB224K	R	0.22 250V	AD
C1101	VCEAGA1HW475M	R	4.7 50V Electrolytic	AB

RESISTORS

R751	VRD-RM2HD391J	R	390 1/2W Carbon	AA
R752	VRW-KP41CR82K	R	0.82 15W Cement	AG
R753	VRW-KP41CR82K	R	0.82 15W Cement	AG
R1101	VRD-RA2BE273J	R	27k 1/8W Carbon	AA
R1102	VRD-RA2BE822J	R	8.2k 1/8W Carbon	AA
R1103	VRD-RA2BE472J	R	4.7k 1/8W Carbon	AA
R1104	VRD-RA2BE222J	R	2.2k 1/8W Carbon	AA
R1105	VRD-RA2BE391J	R	390 1/8W Carbon	AA
R1106	VRD-RA2BE122J	R	1.2k 1/8W Carbon	AA
R1108	VRD-RA2BE331J	R	330 1/8W Carbon	AA
R1109	VRD-RA2BE103J	R	10k 1/8W Carbon	AA

Ref. No.	Part No.	★	Description	Code
R1110	VRD-RA2BE223J	R	22k 1/8W Carbon	AA

SWITCHES

△ S750	QSW-P0588CEZZ	R	Switch, Power	AP
S1101	QSW-K0079GEZZ	R	Switch, CH-Up	AB
S1102	QSW-K0079GEZZ	R	Switch, CH-Down	AB
S1103	QSW-K0079GEZZ	R	Switch, VOL-Up	AB
S1104	QSW-K0079GEZZ	R	Switch, VOL-Down	AB
S1105	QSW-K0079GEZZ	R	Switch, Preset	AB

MISCELLANEOUS PARTS

J303	QTANJ0336CEZZ		Jack	
P402	QPLGN0561CEZZ	R	Plug, 5 Pin	AB
P752	QPLGN0304CEZZ	R	Plug, 3 Pin	AB
P753	QPLGN0304CEZZ	R	Plug, 3 Pin	AB
P754	QPLGN0207CEZZ	R	Plug, 2 Pin	AA
P1101	QPLGN0761CEZZ	R	Plug, 7 Pin	AD
RMC1101	RRMCU0227CEZZ	R	Remote Control Sensor Unit	AK

DUNTK9481WET3 S-OUT UNIT

INTEGRATED CIRCUIT

IC3301	VHiAN5275//-1	R	AN5275	AP
--------	---------------	---	--------	----

TRANSISTORS

Q3301	VS2SC1815GW-1	R	2SC1815GW	AB
Q3302	VS2SC1815GW-1	R	2SC1815GW	AB
Q3303	VSKRC102M//-1	R	KRC102M	AA
Q3304	VSKRC102M//-1	R	KRC102M	AA

DIODES AND VARISTOR

D3301	RH-DX0475CEZZ	R	DX0475CE	AB
D3302	RH-DX0475CEZZ	R	DX0475CE	AB
D3303	RH-DX0475CEZZ	R	DX0475CE	AB
D3304	RH-DX0475CEZZ	R	DX0475CE	AB
△ VA750	RH-VX0048CEZZ	R	Varistor, VX0048CE	AE

COIL

△ L751	RCiLF0031PEZZ	R	Coil	AR
--------	---------------	---	------	----

CAPACITORS

△ C750	RC-FZ012SGEZZ	R	0.22 AC250V	AE
△ C751	RC-FZ008SCEZZ	R	0.1 AC250V	AE
C3301	VCEAGA1HW107M	R	100 50V Electrolytic	AC
C3302	VCEAGA1HW105M	R	1 50V Electrolytic	AC
C3303	VCEAGA1HW336M	R	33 50V Electrolytic	AB
C3304	VCEAGA1HW105M	R	1 50V Electrolytic	AC
C3305	VCEAGA1HW107M	R	100 50V Electrolytic	AC
C3307	VCKYPA1HB562K	R	5600p 50V Ceramic	AA
C3309	VCKYPA1HB562K	R	5600p 50V Ceramic	AA
C3310	VCEAGH1HW108M	R	1000 50V Electrolytic	AE
C3311	VCQYTA1HM104J	R	0.1 50V Mylar	AA
C3312	VCEAGH1HW108M	R	1000 50V Electrolytic	AE
C3313	VCQYTA1HM104J	R	0.1 50V Mylar	AA
C3314	VCEAGH1HW108M	R	1000 50V Electrolytic	AE
C3315	VCEAGA1HW107M	R	100 50V Electrolytic	AC
C3316	VCEAGA1HW225M	R	2.2 50V Electrolytic	AB
C3319	VCEAGA1HW335M	R	3.3 50V Electrolytic	AB
C3333	VCEAGA1HW225M	R	2.2 50V Electrolytic	AB
C3334	VCEAGA1HW225M	R	2.2 50V Electrolytic	AB
C3336	VCEAGA1HW225M	R	2.2 50V Electrolytic	AB

RESISTORS

△ R750	VRC-UA2HG395K	R	3.9M 1/2W Solid	AA
△ R754	VRW-KQ41C1R8K	R	1.8 15W Cement	AG
R3301	VRD-RA2BE102J	R	1k 1/8W Carbon	AA
R3302	VRD-RA2BE103J	R	10k 1/8W Carbon	AA
R3303	VRD-RA2BE102J	R	1k 1/8W Carbon	AA
R3304	VRD-RA2BE103J	R	10k 1/8W Carbon	AA
R3305	VRD-RA2EE2R2J	R	2.2 1/4W Carbon	AA
R3306	VRD-RA2EE2R2J	R	2.2 1/4W Carbon	AA
R3308	VRD-RA2BE223J	R	22k 1/8W Carbon	AA

Ref. No.	Part No.	★	Description	Code	Ref. No.	Part No.	★	Description	Code
DUNTK9481WET3 S-OUT UNIT (Continue)									
R3309	VRD-RA2BE103J	R	10k 1/8W Carbon	AA	D604	RH-DX0475CEZZ	R	DX0475CE	AB
R3310	VRD-RA2BE103J	R	10k 1/8W Carbon	AA	D605	RH-DX0302CEZZ	R	DX0302CE	AC
R3335	VRD-RA2BE681J	R	680 1/8W Carbon	AA	D607	RH-DX0255CEZZ	R	DX0255CE	AC
R3336	VRD-RA2BE472J	R	4.7k 1/8W Carbon	AA	D608	RH-DX0475CEZZ	R	DX0475CE	AB
R3337	VRD-RA2BE472J	R	4.7k 1/8W Carbon	AA	D609	RH-DX0127CEZZ	R	DX0127CE	AC
R3339	VRD-RA2EE103J	R	10k 1/4W Carbon	AA	D610	RH-DX0279CEZZ	R	DX0279CE	AB
R3342	VRD-RA2BE101J	R	100 1/8W Carbon	AB	D611	RH-DX0475CEZZ	R	DX0475CE	AB
MISCELLANEOUS PARTS									
⚠ ACC701	QACCZ3008PEZZ	R	AC Power Cord	AN	D616	RH-DX0475CEZZ	R	DX0475CE	AB
⚠ FH751	QFSDH1013CEZZ	R	Fuse Holder	AC	D701	RH-DX0474CEZZ	R	DX0474CE	AE
⚠ FH752	QFSDH1014CEZZ	R	Fuse Holder	AC	D702	RH-DX0475CEZZ	R	DX0475CE	AB
⚠ F750	QFS-C5026CEZZ	R	Fuse, T5A 250V	AE	D703	RH-EX0619GEZZ	R	Zener, EX0619GE	AA
P750	QPLGN0269GEZZ	R	Plug, 2 Pin	AB	D704	RH-DX0478CEZZ	R	DX0478CE	AL
P751	QPLGN0304CEZZ	R	Plug, 3 Pin	AB	D708	RH-EX0641GEZZ	R	Zener, EX0641GE	AA
P3302	QPLGN0269GEZZ	R	Plug, 2 Pin	AB	D709	RH-DX0471CEZZ	R	DX0471CE	AE
P3304	QPLGN0861CEZZ	R	Plug, 8 Pin	AC	D710	RH-DX0471CEZZ	R	DX0471CE	AE
P3306	QPLGN0561CEZZ	R	Plug, 5 Pin	AB	D711	RH-DX0471CEZZ	R	DX0471CE	AE
SP1	VSP0010PBX18A		Speaker		D712	RH-EX0622GEZZ	R	Zener, EX0622GE	AA
SP2	VSP0010PBX18A		Speaker		D713	RH-DX0130CEZZ	R	DX0130CE	AE
	PRDAR0266PEFW		Heat Sink, for IC3301		D714	RH-DX0229CEZZ	R	DX0229CE	AF
DUNTK9482WET9 MAIN 1 UNIT									
TUNER									
NOTE: THE PARTS HERE SHOWN ARE SUPPLIED AS AN ASSEMBLY BUT INDEPENDENTLY.									
⚠ TU201	VTUVTST6HD64/	R	Tuner	BF	D715	RH-DX0355CEZZ	R	DX0355CE	AF
INTEGRATED CIRCUITS									
IC203	RH-iX0249CEZZ	R	IX0249CE	AE	D716	VHDRL3Z///-1	R	RL3Z	AE
IC302	VHiTDA7429S-1	R	TDA7429S	AG	D717	VHDRL3Z///-1	R	RL3Z	AE
IC402	VHiM51497L/-1	R	M51497L	AL	D718	RH-DX0475CEZZ	R	DX0475CE	AB
IC501	VHiTDA8351A-1	R	TDA8351A	AT	D719	RH-DX0475CEZZ	R	DX0475CE	AB
IC701	VHiSTR6656/-1	R	STR6656	AZ	D720	RH-DX0475CEZZ	R	DX0475CE	AB
IC703	VHiSE120N//1	R	SE120N	AG	D721	RH-DX0475CEZZ	R	DX0475CE	AB
IC704	VHiKA7812PI-1	R	KA7812PI	AE	D1050	RH-DX0475CEZZ	R	DX0475CE	AB
IC705	VHiPQ12RD11-1	R	PQ12RD11	AG	D1051	RH-DX0475CEZZ	R	DX0475CE	AB
IC706	VHiPQ09RD11-1	R	PQ09RD11	AG	D1052	RH-EX0628GEZZ	R	Zener, EX0628GE	AB
IC707	VHiPQ05RD11-1	R	PQ05RD11	AG	⚠ IC702	RH-FX0024CEZZ	R	PC113L	AG
TRANSISTORS					COILS AND TRANSFORMERS				
Q210	VS2SC1906//1E	R	2SC1906	AC	CF401	RFILA0020CEZZ	R	Filter	AD
Q303	VS2SC1815GW-1	R	2SC1815	AB	JA406	VP-XF180K0000	R	Peaking 18μH	AB
Q304	VS2SC1815GW-1	R	2SC1815	AB	L202	VP-XF1R2K0000	R	Peaking 1.2μH	AB
Q404	VS2SA1015Y/1E	R	2SA1015Y	AC	L203	VP-XF150K0000	R	Peaking 15μH	AB
Q405	VS2SC1815GW-1	R	2SC1815	AB	L204	VP-MK100K0000	R	Peaking 10μH	AB
Q406	VS2SC1815GW-1	R	2SC1815	AB	L601	RCiLZ0015PEZZ	R	Coil	AL
Q407	VS2SK583///-1	R	2SK583	AE	L603	RCiLZ0013PEZZ	R	Coil	AM
Q502	VS2SA1015Y/1E	R	2SA1015Y	AC	L604	VP-CF390K0000	R	Peaking 39μH	AB
⚠ Q605	VS2SC3886A/1E	R	2SC3886A	AP	L701	RCLP0226CEZZ	R	Coil	AD
Q606	VS2SC3808//1	R	2SC3808	AH	⚠ T601	RTRNF0160PEZZ	R	H-Volt Transformer	BE
Q701	VS2SA1015Y/1E	R	2SA1015Y	AC	⚠ T602	RTRNZ0343CEZZ	R	Transformer	AG
Q702	VS2SC1815GW-1	R	2SC1815	AB	⚠ T701	RTRNZ0128PEZZ	R	Transformer	AX
Q703	VS2SC1815GW-1	R	2SC1815	AB	CAPACITORS				
Q1005	VS2SA1015Y/1E	R	2SA1015Y	AC	<i>(M-Poly.Film : Metalized Polypro Film)</i>				
DIODES					C220	VCEAGA1CW226M	R	22 16V Electrolytic	AB
D202	RH-EX0619GEZZ	R	Zener, EX0619GE	AA	C221	VCEAGA1CW107M	R	100 16V Electrolytic	AB
D203	RH-EX0619GEZZ	R	Zener, EX0619GE	AA	C222	VCEAGA1HW106M	R	10 50V Electrolytic	AC
D310	RH-EX0628GEZZ	R	Zener, EX0628GE	AC	C223	VCEAGA1CW107M	R	100 16V Electrolytic	AB
D311	RH-EX0628GEZZ	R	Zener, EX0628GE	AC	C224	VCKYPA1HB102K	R	1000p 50V Ceramic	AA
D312	RH-EX0628GEZZ	R	Zener, EX0628GE	AC	C225	VCEAGA1CW337M	R	330 16V Electrolytic	AC
D313	RH-EX0628GEZZ	R	Zener, EX0628GE	AC	C227	VCKYPA1HF103Z	R	0.01 50V Ceramic	AA
D401	RH-EX0628GEZZ	R	Zener, EX0628GE	AC	C228	VCKYPA1HF103Z	R	0.01 50V Ceramic	AA
D402	RH-EX0628GEZZ	R	Zener, EX0628GE	AC	C229	VCKYPA1HF103Z	R	0.01 50V Ceramic	AA
D403	RH-EX0628GEZZ	R	Zener, EX0628GE	AC	C230	VCQYTA1HM182J	R	1800p 50V Mylar	AA
D503	RH-DX0475CEZZ	R	DX0475CE	AB	C231	VCKYD41HB102K	R	1000p 50V Ceramic	AA
D601	RH-EX0651GEZZ	R	Zener, EX0651GE	AB	C320	VCQYTA1HM223J	R	0.022 50V Mylar	AA
D602	RH-DX0127CEZZ	R	DX0127CE	AC	C321	VCQYTA1HM223J	R	0.022 50V Mylar	AA
D603	RH-EX0628GEZZ	R	Zener, EX0628GE	AC	C322	VCQYTA1HM472J	R	4700p 50V Mylar	AB
					C323	VCFYFA1HA104J	R	0.1 50V M. Polypro	AA
					C324	VCQYTA1HM122J	R	1200p 50V Mylar	AA
					C325	VCQYTA1HM562J	R	5600p 50V Mylar	AA
					C326	VCFYFA1HA684J	R	0.68 50V M. Polypro	AD
					C327	VCEAGA1HW225M	R	2.2 50V Electrolytic	AB
					C328	VCEAGA1HW225M	R	2.2 50V Electrolytic	AB
					C329	VCEAGA1HW225M	R	2.2 50V Electrolytic	AB
					C330	VCFYFA1HA104J	R	0.1 50V M. Polypro	AA
					C331	VCFYFA1HA104J	R	0.1 50V M. Polypro	AA
					C332	VCFYFA1HA104J	R	0.1 50V M. Polypro	AA
					C333	VCFYFA1HA104J	R	0.1 50V M. Polypro	AA
					C334	VCQYTA1HM223J	R	0.022 50V Mylar	AA
					C335	VCQYTA1HM183J	R	0.018 50V Mylar	AA
					C336	VCQYTA1HM223J	R	0.022 50V Mylar	AA

Ref. No.	Part No.	★	Description	Code	Ref. No.	Part No.	★	Description	Code					
DUNTK9482WET9 MAIN 1 UNIT (Continue)														
C337	VCQYTA1HM183J	R	0.018 50V Mylar	AB	C710	RC-KZ0016CEZZ	R	0.01 1.5kV Ceramic	AC					
C338	VCQYTA1HM562J	R	5600p 50V Mylar	AA	C711	RC-KZ0016CEZZ	R	0.01 1.5kV Ceramic	AC					
C339	VCQYTA1HM562J	R	5600p 50V Mylar	AA	C712	RC-KZ0016CEZZ	R	0.01 1.5kV Ceramic	AC					
C340	VCEAGA1HW225M	R	2.2 50V Electrolytic	AB	C713	RC-KZ0016CEZZ	R	0.01 1.5kV Ceramic	AC					
C341	VCKYPA1HB102K	R	1000p 50V Ceramic	AA	C714	VCFYFA1HA104J	R	0.1 50V M. Polypro	AA					
C342	VCKYPA1HB102K	R	1000p 50V Ceramic	AA	C715	VCFYFA1HA104J	R	0.1 50V M. Polypro	AA					
C343	VCEAGA1CW106M	R	10 16V Electrolytic	AA	C716	VCEAGA1CW477M	R	470 16V Electrolytic	AC					
C344	VCEAGA1CW106M	R	10 16V Electrolytic	AA	C717	VCEAGA1CW477M	R	470 16V Electrolytic	AC					
C345	VCEAGA1HW225M	R	2.2 50V Electrolytic	AB	C718	VCEAGA1CW477M	R	470 16V Electrolytic	AC					
C346	VCEAGA1HW225M	R	2.2 50V Electrolytic	AB	△ C719	RC-KZ017SCEZZ	R	680p 4kV Special	AD					
C347	VCEAGA1HW225M	R	2.2 50V Electrolytic	AB	C720	VCEAGA1CW477M	R	470 16V Electrolytic	AC					
C348	VCFYFA1HA474J	R	0.47 50V M. Polypro	AC	C721	VCKYPA2HB102K	R	1000p 500V Ceramic	AA					
C349	VCFYFA1HA474J	R	0.47 50V M. Polypro	AC	C722	RC-KZ0024CEZZ	R	1000p 2kV Ceramic	AC					
C350	VCFYFA1HA474J	R	0.47 50V M. Polypro	AC	C723	RC-KZ0037CEZZ	R	390p 2kV Ceramic	AB					
C351	VCFYFA1HA474J	R	0.47 50V M. Polypro	AC	C724	VCEAGA1EW108M	R	1000 25V Electrolytic	AD					
C352	VCFYFA1HA474J	R	0.47 50V M. Polypro	AC	C725	VCEAGH1HW228M	R	2200 50V Electrolytic	AG					
C353	VCFYFA1HA474J	R	0.47 50V M. Polypro	AC	C726	VCEAGA1CW227M	R	220 16V Electrolytic	AC					
C354	VCEAGA1CW226M	R	22 16V Electrolytic	AB	C727	RC-EZ0400CEZZ	R	270 200V Electrolytic	AM					
C355	VCEAGA1CW106M	R	10 16V Electrolytic	AA	C728	VCEAGW2CW227M	R	220 160V Electrolytic	AK					
C356	VCFYFA1HA104J	R	0.1 50V M. Polypro	AA	C730	RC-EZ0695CEZZ	R	330 450V Electrolytic	AW					
C417	VCEAGA1AW477M	R	470 10V Electrolytic	AC	C731	RC-EZ0695CEZZ	R	330 450V Electrolytic	AW					
C418	VCEAGA1CW106M	R	10 16V Electrolytic	AA	C733	VCKYD41HB102K	R	1000p 50V Ceramic	AA					
C419	VCEAGA1HW475M	R	4.7 50V Electrolytic	AB	C734	VCKYPA1HB102K	R	1000p 50V Ceramic	AA					
C420	VCKYPA1HB331K	R	330p 50V Ceramic	AA	C735	VCEAGA1HW475M	R	4.7 50V Electrolytic	AB					
C421	VCKYPA1HB182K	R	1800p 50V Ceramic	AA	C738	VCFYFA1HA474J	R	0.47 50V M. Polypro	AC					
C422	VCEAGA1HW224M	R	0.22 50V Electrolytic	AA	C739	VCKYPA2HB222K	R	2200p 500V Ceramic	AA					
C423	VCFYFA1HA104J	R	0.1 50V M. Polypro	AA	C1001	VCEAGA1AW227M	R	220 10V Electrolytic	AB					
C424	VCEAGA1CW106M	R	10 16V Electrolytic	AA	C1002	VCEAGA1CW476M	R	47 16V Electrolytic	AB					
C425	VCKYPA1HF103Z	R	0.01 50V Ceramic	AA	C1426	VCQYTA1HM223J	R	0.022 50V Mylar	AA					
C504	VCKYPA1HB102K	R	1000p 50V Ceramic	AA	RESISTORS									
C505	VCFYFA1HA104J	R	0.1 50V M. Polypro	AA	R15	VRD-RA2BE270J	R	27 1/8W Carbon	AA					
C506	VCEAGA1EW108M	R	1000 25V Electrolytic	AD	R221	VRD-RA2BE151J	R	150 1/8W Carbon	AA					
C508	VCEAGA1HW106M	R	10 50V Electrolytic	AC	R222	VRD-RA2BE101J	R	100 1/8W Carbon	AB					
C511	VCFYFA1HA104J	R	0.1 50V M. Polypro	AA	R224	VRD-RA2BE472J	R	4.7k 1/8W Carbon	AA					
C512	VCQYSG2AA473K	R	0.047 100V Mylar	AC	R226	VRD-RA2BE122J	R	1.2k 1/8W Carbon	AA					
C513	VCKYPA1HB102K	R	1000p 50V Ceramic	AA	R227	VRS-VV3DB153J	R	15k 2W Metal Oxide	AA					
C514	VCKYPA1HB102K	R	1000p 50V Ceramic	AA	R228	VRD-RA2BE273J	R	27k 1/8W Carbon	AA					
C515	VCQYTA1HM103J	R	0.01 50V Mylar	AA	R229	VRD-RA2BE223J	R	22k 1/8W Carbon	AA					
C516	VCFYAA2AA103J	R	0.01 100V	AF	R230	VRD-RA2BE181J	R	180 1/8W Carbon	AA					
C518	VCCCPA1HH560J	R	56p 50V Ceramic	AA	R320	VRD-RA2BE222J	R	2.2k 1/8W Carbon	AA					
C610	VCFPPC2DB184J	R	0.18 200V M-Poly.Film	AD	R321	VRD-RA2BE682J	R	6.8k 1/8W Carbon	AA					
C612	RC-KZ0039CEZZ	R	680p 2kV Ceramic	AB	R322	VRD-RA2BE562J	R	5.6k 1/8W Carbon	AA					
C613	VCFPPD3CA622H	R	6200p 1600V M-Poly.Film	AE	R323	VRD-RA2BE562J	R	5.6k 1/8W Carbon	AA					
C614	VCFPPD3CA682H	R	6800p 1600V M-Poly.Film	AE	R324	VRD-RA2BE272J	R	2.7k 1/8W Carbon	AA					
C615	VCFYFA1HA104J	R	0.1 50V M. Polypro	AA	R325	VRD-RA2BE101J	R	100 1/8W Carbon	AB					
C616	VCKYPA1HB472K	R	4700p 50V Ceramic	AA	R326	VRD-RA2BE564J	R	560k 1/8W Carbon	AA					
C617	VCFPPD2DB474J	R	0.47 200V M-Poly.Film	AE	R327	VRD-RA2BE102J	R	1k 1/8W Carbon	AA					
C618	VCFYSB2EB224K	R	0.22 250V	AD	R328	VRD-RA2BE564J	R	560k 1/8W Carbon	AA					
C619	VCKYPA2HB102K	R	1000p 500V Ceramic	AA	R329	VRD-RA2BE102J	R	1k 1/8W Carbon	AA					
C620	VCEAGA2AW106M	R	10 100V Electrolytic	AC	R330	VRD-RA2BE272J	R	2.7k 1/8W Carbon	AA					
C621	VCEAGA1HW106M	R	10 50V Electrolytic	AC	R331	VRD-RA2BE564J	R	560k 1/8W Carbon	AA					
C622	VCKYPA1HB102K	R	1000p 50V Ceramic	AA	R332	VRD-RA2BE102J	R	1k 1/8W Carbon	AA					
C623	VCEAGA1EW227M	R	220 25V Electrolytic	AC	R333	VRD-RA2BE331J	R	330 1/8W Carbon	AA					
C624	VCQYTA1HM273J	R	0.027 50V Mylar	AB	R334	VRD-RA2BE331J	R	330 1/8W Carbon	AA					
C625	VCKYPA2HB102K	R	1000p 500V Ceramic	AA	R335	VRD-RA2BE104J	R	100k 1/8W Carbon	AA					
C626	VCEAGH1EW228M	R	2200 25V Electrolytic	AE	R336	VRD-RA2BE104J	R	100k 1/8W Carbon	AA					
C627	RC-KZ0039CEZZ	R	680p 2kV Ceramic	AB	R337	VRD-RA2BE331J	R	330 1/8W Carbon	AA					
C628	VCFPPD3CA472J	R	4700p 1600V M-Poly.Film	AD	R338	VRD-RA2BE331J	R	330 1/8W Carbon	AA					
C629	VCFYAB2AA335J	R	3.3 100V	AL	R339	VRD-RA2BE473J	R	47k 1/8W Carbon	AA					
C630	VCEAGA1HW335M	R	3.3 50V Electrolytic	AB	R340	VRD-RA2BE472J	R	4.7k 1/8W Carbon	AA					
C631	VCKYPA1HB102K	R	1000p 50V Ceramic	AA	R341	VRD-RA2BE473J	R	47k 1/8W Carbon	AA					
C632	VCKYPA2HB102K	R	1000p 500V Ceramic	AA	R342	VRD-RA2BE472J	R	4.7k 1/8W Carbon	AA					
C633	VCEAGA2EW336M	R	33 250V Electrolytic	AD	R343	VRD-RA2BE102J	R	1k 1/8W Carbon	AA					
C634	VCKYPA2HB561K	R	560p 500V Ceramic	AA	R344	VRD-RA2BE564J	R	560k 1/8W Carbon	AA					
C635	VCFPPD2DB394J	R	0.39 200V M-Poly.Film	AE	R345	VRD-RA2BE101J	R	100 1/8W Carbon	AB					
C636	VCFYFA1HA104J	R	0.1 50V M. Polypro	AA	R347	VRD-RA2BE102J	R	1k 1/8W Carbon	AA					
C703	VCQPSC2JA333K	R	0.033 630V	AB	R348	VRD-RA2BE681J	R	680 1/8W Carbon	AA					
C704	RC-KZ0035CEZZ	R	220p 2kV Ceramic	AB	R421	VRD-RA2EE680J	R	68 1/4W Carbon	AA					
C705	VCKYPA1HB222K	R	2200p 50V Ceramic	AA	R422	VRD-RA2BE104J	R	100k 1/8W Carbon	AA					
C706	VCKYPH3DB561K	R	560p 2000V Ceramic	AC	R427	VRD-RA2BE103J	R	10k 1/8W Carbon	AA					
C707	VCKYPA1HB471K	R	470p 50V Ceramic	AA	R428	VRD-RA2BE103J	R	10k 1/8W Carbon	AA					
C708	VCEAGA1VW107M	R	100 35V Electrolytic	AC	R429	VRD-RA2BE471J	R	470 1/8W Carbon	AA					
C709	RC-KZ0035CEZZ	R	220p 2kV Ceramic	AB	R430	VRD-RA2BE184J	R	180k 1/8W Carbon	AA					
					R431	VRD-RA2BE471J	R	470 1/8W Carbon	AA					

Ref. No.	Part No.	★	Description	Code	Ref. No.	Part No.	★	Description	Code
DUNTK9482WET9 MAIN 1 UNIT (Continue)									
R432	VRD-RA2BE271J	R 270	1/8W Carbon	AA	R1002	VRD-RA2BE103J	R 10k	1/8W Carbon	AA
R433	VRD-RA2BE562J	R 5.6k	1/8W Carbon	AA	R1003	VRD-RA2BE562J	R 5.6k	1/8W Carbon	AA
R435	VRD-RA2BE684J	R 680k	1/8W Carbon	AA	R1004	VRD-RA2BE103J	R 10k	1/8W Carbon	AA
R440	VRD-RA2BE472J	R 4.7k	1/8W Carbon	AA	R1005	VRD-RA2BE103J	R 10k	1/8W Carbon	AA
R441	VRD-RA2BE222J	R 2.2k	1/8W Carbon	AA	R1020	VRD-RM2HD330J	R 33	1/2W Carbon	AA
R442	VRD-RA2BE392J	R 3.9k	1/8W Carbon	AA	R1021	VRD-RA2BE101J	R 100	1/8W Carbon	AB
R443	VRD-RA2BE472J	R 4.7k	1/8W Carbon	AA	R1022	VRD-RA2BE101J	R 100	1/8W Carbon	AB
R444	VRD-RA2BE223J	R 22k	1/8W Carbon	AA	R1445	VRD-RA2BE223J	R 22k	1/8W Carbon	AA
R445	VRD-RA2BE223J	R 22k	1/8W Carbon	AA	R1446	VRD-RA2BE223J	R 22k	1/8W Carbon	AA
R446	VRD-RA2BE333J	R 33k	1/8W Carbon	AA	MISCELLANEOUS PARTS				
R447	VRD-RA2EE750J	R 75	1/4W Carbon	AA	FB601	RBLN-0037CEZZ	R	Balun	AB
R448	VRD-RA2EE750J	R 75	1/4W Carbon	AA	FB602	RBLN-0037CEZZ	R	Balun	AB
R503	VRD-RA2BE332J	R 3.3k	1/8W Carbon	AA	FB701	RBLN-0037CEZZ	R	Balun	AB
R504	VRN-VV3AB2R2J	R 2.2	1W Metal Film	AA	FB702	RBLN-0037CEZZ	R	Balun	AB
R505	VRN-VV3AB2R2J	R 2.2	1W Metal Film	AA	FB703	RBLN-0037CEZZ	R	Balun	AB
R508	VRD-RA2BE103J	R 10k	1/8W Carbon	AA	FB704	RBLN-0037CEZZ	R	Balun	AB
R509	VRS-VV3DB151J	R 150	2W Metal Oxide	AA	FB705	RBLN-0037CEZZ	R	Balun	AB
R510	VRD-RA2BE180J	R 18	1/8W Carbon	AA	FB706	RBLN-0037CEZZ	R	Balun	AB
R511	VRD-RA2BE562J	R 5.6k	1/8W Carbon	AA	J402	QTANJ0639CEZZ	R	Terminal, Audio/Video	AL
⚠ R512	RR-XZ0020CEZZ	R 39	1/4W Fuse Resistor	AB	P201	QPLGN0261CEZZ	R	Plug, 2 Pin	AB
R612	VRD-RA2BE275J	R 2.7M	1/8W Carbon	AA	P202	QPLGN2059REZZ	R	Plug, 20 Pin	AE
R613	VRS-VV3DB561J	R 560	2W Metal Oxide	AA	P203	QPLGN2059REZZ	R	Plug, 20 Pin	AE
R614	VRW-KQ41C3R3K	R 3.3	15W Cement	AG	P204	QPLGZ0360GEZZ	R	Plug, 3 Pin	AB
R615	VRD-RA2BE563J	R 56k	1/8W Carbon	AA	P205	QPLGN2059REZZ	R	Plug, 20 Pin	AE
R616	VRN-RV3DB2R2J	R 2.2	2W Metal Film	AB	P303	QPLGN0561CEZZ	R	Plug, 5 Pin	AB
R617	VRD-RA2EE101J	R 100	1/4W Carbon	AA	P401	QPLGN0561CEZZ	R	Plug, 5 Pin	AB
R618	VRD-RA2EE101J	R 100	1/4W Carbon	AA	P601	QPLGN0160FJZZ	R	Plug, 5 Pin	AD
R619	VRD-RA2BE104J	R 100k	1/8W Carbon	AA	P602	QPLGN0361CEZZ	R	Plug, 3 Pin	AB
⚠ R620	RR-XZ0016CEZZ	R 1	1/2W Fuse Resistor	AB	P701	QPLGN0269GEZZ	R	Plug, 2 Pin	AB
R621	VRD-RA2BE104J	R 100k	1/8W Carbon	AA	P702	QPLGN0304CEZZ	R	Plug, 3 Pin	AB
R622	VRS-SU2HB102J	R 1k	1/2W Metal Oxide	AA	P1001	QPLGN0761CEZZ	R	Plug, 7 Pin	AD
R623	VRD-RA2BE223J	R 22k	1/8W Carbon	AA	P1002	QPLGN0461CEZZ	R	Plug, 4 Pin	AB
R624	VRD-RA2BE103J	R 10k	1/8W Carbon	AA	S1006	QSW-B0015CEZZ	R	Switch, Normal/Service	AC
R625	VRD-RA2EE125J	R 1.2M	1/4W Carbon	AA	SC601	QTiPM0083CEZZ	R	Tip	AB
R626	VRD-RA2BE274J	R 270k	1/8W Carbon	AA	PRDAR0244PEFW	R	Heat Sink, for IC501	AN	
R627	VRD-RA2BE563J	R 56k	1/8W Carbon	AA	PRDAR0245PEFW	R	Heat Sink, for Q605	AH	
R628	VRD-RA2BE474J	R 470k	1/8W Carbon	AA	PRDAR0246PEFW	R	Heat Sink, for IC701	AN	
R629	VRS-VV3AB472J	R 4.7k	1W Metal Oxide	AA	PRDAR0250PEFW	R	Heat Sink, for IC704/705/706/707	AM	
R630	VRD-RA2EE102J	R 1k	1/4W Carbon	AA	PRDAR0253PEFW	R	Heat Sink, for D715	AE	
R632	VRD-RM2HD820J	R 82	1/2W Carbon	AA	DUNTK9483WEW4 MAIN 2 UNIT				
R633	VRD-RM2HD470J	R 47	1/2W Carbon	AA	INTEGRATED CIRCUITS				
⚠ R636	RR-XZ0029CEZZ	R 3.3	1/2W Fuse Resistor	AB	IC201	VHITDA8375A-3	R	TDA8375	BA
R637	VRW-KX3HC180J	R 18	5W Cement	AE	IC202	VHiKA7808Pi-1	R	KA7808PI	AF
⚠ R638	RR-XZ0071CEZZ	R 1	1W Fuse Resistor	AC	IC401	VHITDA4671/-1	R	TDA4671	AZ
R643	VRS-KT3LB101J	R 100	3W Metal Oxide	AC	IC801	VHITDA4665T-1	R	TDA4665T	AN
R644	VRD-RA2BE391J	R 390	1/8W Carbon	AA	IC1001	RH-iX3097CEN2	R	IX3097CE	BA
R701	VRS-KT3LB103J	R 10k	3W Metal Oxide	AF	IC1002	VHiS24C04A/-1	R	S24C04A	AL
R702	VRN-SV2HBR27J	R 0.27	1/2W Metal Film	AB	IC1003	VHiKiA7045P-1	R	KIA7045P	AD
R703	VRD-RM2HD684J	R 680k	1/2W Carbon	AA	IC1004	VHiKA7805Pi-1	R	KA7805PI	AE
R704	VRD-RA2BE333J	R 33k	1/8W Carbon	AA	TRANSISTORS				
R705	VRN-SV2HBR27J	R 0.27	1/2W Metal Film	AB	Q202	VS2SC2412KQ-1	R	2SC2412KQ	AA
R706	VRN-SV2HBR27J	R 0.27	1/2W Metal Film	AB	Q203	VS2SC2412KQ-1	R	2SC2412KQ	AA
R707	VRD-RA2BE681J	R 680	1/8W Carbon	AA	Q204	VS2SC2412KQ-1	R	2SC2412KQ	AA
R708	VRD-RA2BE152J	R 1.5k	1/8W Carbon	AA	Q301	VS2SC2412KQ-1	R	2SC2412KQ	AA
R709	VRD-RA2BE152J	R 1.5k	1/8W Carbon	AA	Q401	VS2SC2412KQ-1	R	2SC2412KQ	AA
R710	VRD-RA2BE103J	R 10k	1/8W Carbon	AA	Q402	VS2SC2412KQ-1	R	2SC2412KQ	AA
R712	VRD-RA2BE102J	R 1k	1/8W Carbon	AA	Q403	VS2SC2412KQ-1	R	2SC2412KQ	AA
R713	VRN-KT3LB4R7J	R 4.7	3W Metal Film	AG	Q601	VS2SC2412KQ-1	R	2SC2412KQ	AA
R714	VRD-RA2BE562J	R 5.6k	1/8W Carbon	AA	Q602	VS2SC2412KQ-1	R	2SC2412KQ	AA
R715	VRD-RA2BE123J	R 12k	1/8W Carbon	AA	Q603	VS2SC2412KQ-1	R	2SC2412KQ	AA
⚠ R716	VRC-UA2HG825K	R 8.2M	1/2W Solid	AA	Q1001	VS2SA1037KQ-1	R	2SA1037KQ	AA
⚠ R717	VRC-UA2HG825K	R 8.2M	1/2W Solid	AA	Q1002	VS2SC2412KQ-1	R	2SC2412KQ	AA
R718	VRD-RA2BE102J	R 1k	1/8W Carbon	AA	Q1004	VS2SC2412KQ-1	R	2SC2412KQ	AA
R719	VRD-RA2BE332J	R 3.3k	1/8W Carbon	AA	DIODES				
R720	VRN-VV3DB6R8J	R 6.8	2W Metal Film	AB	D204	RH-DX0475CEZZ	R	DX0475CE	AB
R721	VRD-RA2BE102J	R 1k	1/8W Carbon	AA	D301	RH-DX0475CEZZ	R	DX0475CE	AB
R722	VRS-SV3AB683J	R 68k	1W Metal Oxide	AA	D302	RH-DX0475CEZZ	R	DX0475CE	AB
R723	VRD-RA2BE472J	R 4.7k	1/8W Carbon	AA					
R724	VRD-RA2BE472J	R 4.7k	1/8W Carbon	AA					
R725	VRN-KT3LB2R2J	R 2.2	3W Metal Film	AF					
R726	VRD-RA2BE102J	R 1k	1/8W Carbon	AA					
R732	VRN-KT3LB6R8J	R 6.8	3W Metal Film	AG					
R1001	VRD-RA2BE561J	R 560	1/8W Carbon	AA					

Ref. No.	Part No.	★	Description	Code	Ref. No.	Part No.	★	Description	Code
DUNTK9483WEW4 MAIN 2 UNIT (Continue)									
R310	VRS-CY1JF332J	R 3.3k	1/16W Metal Oxide	AA	R1052	VRS-CY1JF561J	R 560	1/16W Metal Oxide	AA
R311	VRS-CY1JF102J	R 1k	1/16W Metal Oxide	AA	R1053	VRS-CY1JF561J	R 560	1/16W Metal Oxide	AA
R312	VRS-CY1JF221J	R 220	1/16W Metal Oxide	AA	R1054	VRS-CY1JF472J	R 4.7k	1/16W Metal Oxide	AA
R313	VRS-CY1JF221J	R 220	1/16W Metal Oxide	AA	R1055	VRS-CY1JF472J	R 4.7k	1/16W Metal Oxide	AA
R314	VRS-CY1JF153J	R 15k	1/16W Metal Oxide	AA	R1056	VRS-CY1JF472J	R 4.7k	1/16W Metal Oxide	AA
R315	VRD-RA2BE472J	R 4.7k	1/8W Carbon	AA	R1057	VRS-CY1JF472J	R 4.7k	1/16W Metal Oxide	AA
R316	VRS-CY1JF223J	R 22k	1/16W Metal Oxide	AA	R1058	VRS-CY1JF562J	R 5.6k	1/16W Metal Oxide	AA
R317	VRS-CY1JF102J	R 1k	1/16W Metal Oxide	AA	R1059	VRS-CY1JF392J	R 3.9k	1/16W Metal Oxide	AA
R401	VRS-CY1JF470J	R 47	1/16W Metal Oxide	AA	R1061	VRS-CY1JF101J	R 100	1/16W Metal Oxide	AA
R402	VRS-CY1JF331J	R 330	1/16W Metal Oxide	AA	R1062	VRS-CY1JF103J	R 10k	1/16W Metal Oxide	AA
R403	VRS-CY1JF471J	R 470	1/16W Metal Oxide	AA	R1063	VRS-CY1JF101J	R 100	1/16W Metal Oxide	AA
R404	VRS-CY1JF471J	R 470	1/16W Metal Oxide	AA	R1064	VRS-CY1JF101J	R 100	1/16W Metal Oxide	AA
R406	VRS-CY1JF222J	R 2.2k	1/16W Metal Oxide	AA	R1065	VRS-CY1JF392J	R 3.9k	1/16W Metal Oxide	AA
R407	VRS-CY1JF122J	R 1.2k	1/16W Metal Oxide	AA	R1066	VRS-CY1JF101J	R 100	1/16W Metal Oxide	AA
R408	VRS-CY1JF392J	R 3.9k	1/16W Metal Oxide	AA	R1067	VRS-CY1JF682J	R 6.8k	1/16W Metal Oxide	AA
R409	VRS-CY1JF000J	R 0	1/16W Metal Oxide	AA	R1068	VRS-CY1JF101J	R 100	1/16W Metal Oxide	AA
R410	VRD-RM2HD151J	R 150	1/2W Carbon	AA	R1069	VRS-CY1JF392J	R 3.9k	1/16W Metal Oxide	AA
R411	VRS-CY1JF104J	R 100k	1/16W Metal Oxide	AA	R1070	VRS-CY1JF101J	R 100	1/16W Metal Oxide	AA
R412	VRS-CY1JF102J	R 1k	1/16W Metal Oxide	AA	R1071	VRS-CY1JF682J	R 6.8k	1/16W Metal Oxide	AA
R413	VRS-CY1JF394J	R 390k	1/16W Metal Oxide	AA	R1072	VRS-CY1JF102J	R 1k	1/16W Metal Oxide	AA
R414	VRS-CY1JF101J	R 100	1/16W Metal Oxide	AA	R1073	VRS-CY1JF102J	R 1k	1/16W Metal Oxide	AA
R415	VRS-CY1JF5R6J	R 5.6	1/16W Metal Oxide	AA	R1076	VRS-CY1JF101J	R 100	1/16W Metal Oxide	AA
R416	VRS-CY1JF100J	R 10	1/16W Metal Oxide	AA	R1077	VRD-RM2HD470J	R 47	1/2W Carbon	AA
R417	VRS-CY1JF223J	R 22k	1/16W Metal Oxide	AA	R1078	VRS-CY1JF333J	R 33k	1/16W Metal Oxide	AA
R418	VRS-CY1JF153J	R 15k	1/16W Metal Oxide	AA	R1079	VRS-CY1JF332J	R 3.3k	1/16W Metal Oxide	AA
R419	VRS-CY1JF101J	R 100	1/16W Metal Oxide	AA	R1086	VRS-CY1JF101J	R 100	1/16W Metal Oxide	AA
R420	VRS-CY1JF101J	R 100	1/16W Metal Oxide	AA	R1087	VRS-CY1JF101J	R 100	1/16W Metal Oxide	AA
R501	VRS-CY1JF393F	R 39k	1/16W Metal Oxide	AA	R1089	VRS-CY1JF102J	R 1k	1/16W Metal Oxide	AA
R601	VRS-CY1JF103J	R 10k	1/16W Metal Oxide	AA	R1090	VRD-RA2BE102J	R 1k	1/8W Carbon	AA
R602	VRS-CY1JF101J	R 100	1/16W Metal Oxide	AA	R1092	VRS-CY1JF682J	R 6.8k	1/16W Metal Oxide	AA
R603	VRD-RM2HD151J	R 150	1/2W Carbon	AA	R1094	VRD-RM2HD1R5J	R 1.5	1/2W Carbon	AA
R604	VRS-CY1JF330J	R 33	1/16W Metal Oxide	AA	R1095	VRS-CY1JF101J	R 100	1/16W Metal Oxide	AA
R605	VRS-CY1JF273J	R 27k	1/16W Metal Oxide	AA	R1096	VRS-CY1JF101J	R 100	1/16W Metal Oxide	AA
R606	VRS-CY1JF153J	R 15k	1/16W Metal Oxide	AA	R1099	VRS-CY1JF102J	R 1k	1/16W Metal Oxide	AA
R607	VRS-CY1JF101J	R 100	1/16W Metal Oxide	AA	MISCELLANEOUS PARTS				
R608	VRS-CY1JF182J	R 1.8k	1/16W Metal Oxide	AA	P801	QPLGN0542CEZZ	R Plug, 5 Pin		AB
R609	VRS-CY1JF1R0J	R 1	1/16W Metal Oxide	AA	SC202	QSOCZ2050CEZZ	R Socket, 20 Pin		AF
R611	VRS-CY1JF103J	R 10k	1/16W Metal Oxide	AA	SC203	QSOCZ2050CEZZ	R Socket, 20 Pin		AF
R801	VRS-CY1JF104J	R 100k	1/16W Metal Oxide	AA	SC204	QSOCZ0360GEZZ	R Socket, 20 Pin		AC
R802	VRS-CY1JF101J	R 100	1/16W Metal Oxide	AA	SC205	QSOCZ2050CEZZ	R Socket, 3 Pin		AF
R803	VRS-CY1JF101J	R 100	1/16W Metal Oxide	AA	SLD201	PSLDM0254PEFW	R Shield		AE
R804	VRS-CY1JF101J	R 100	1/16W Metal Oxide	AA	SLD202	PSLDM0255PEFW	R Shield		AD
R805	VRS-CY1JF100J	R 10	1/16W Metal Oxide	AA	SLD1001	PSLDM0244PEFW	R Shield		AD
R1007	VRS-CY1JF563J	R 56k	1/16W Metal Oxide	AA	SLD1002	PSLDM0245PEFW	R Shield		AD
R1012	VRS-CY1JF562J	R 5.6k	1/16W Metal Oxide	AA	DUNTK9486WET4 CRT UNIT				
R1013	VRS-CY1JF101J	R 100	1/16W Metal Oxide	AA	INTEGRATED CIRCUIT				
R1014	VRD-RA2BE103J	R 10k	1/8W Carbon	AA	IC851	VHITDA6107Q-1	R TDA6107Q		AP
R1015	VRS-CY1JF103J	R 10k	1/16W Metal Oxide	AA	DIODES AND VARISTORS				
R1016	VRS-CY1JF103J	R 10k	1/16W Metal Oxide	AA	D851	RH-EX0623GEZZ	R Zener, EX0623GE		AA
R1017	VRS-CY1JF472J	R 4.7k	1/16W Metal Oxide	AA	D852	VHD1SS244/-1	R 1SS244		AB
R1018	VRS-CY1JF222J	R 2.2k	1/16W Metal Oxide	AA	D853	VHD1SS244/-1	R 1SS244		AB
R1023	VRS-CY1JF562J	R 5.6k	1/16W Metal Oxide	AA	D854	VHD1SS244/-1	R 1SS244		AB
R1024	VRS-CY1JF101J	R 100	1/16W Metal Oxide	AA	VA851	RH-VX0050CEZZ	R Varistor, VX0050CE		AE
R1025	VRS-CY1JF103J	R 10k	1/16W Metal Oxide	AA	VA852	RH-VX0050CEZZ	R Varistor, VX0050CE		AE
R1026	VRS-CY1JF102J	R 1k	1/16W Metal Oxide	AA	COIL				
R1029	VRS-CY1JF562J	R 5.6k	1/16W Metal Oxide	AA	L851	VP-CF681K0000	R Peaking 680µH		AB
R1030	VRS-CY1JF562J	R 5.6k	1/16W Metal Oxide	AA	CAPACITORS				
R1031	VRS-CY1JF562J	R 5.6k	1/16W Metal Oxide	AA	C852	VCFYSB2EB224K	R 0.22 250V		AD
R1032	VRS-CY1JF563J	R 56k	1/16W Metal Oxide	AA	△ C854	RC-KZ0153CEZZ	R 0.001 1.5kV		AB
R1033	VRS-CY1JF101J	R 100	1/16W Metal Oxide	AA	C855	VCEAGA2EW106M	R 10 250V Electrolytic		AC
R1034	VRS-CY1JF563J	R 56k	1/16W Metal Oxide	AA	C857	VCKYPA1HB391K	R 390p 50V Ceramic		AA
R1036	VRS-CY1JF101J	R 100	1/16W Metal Oxide	AA	C858	VCKYPA1HB391K	R 390p 50V Ceramic		AA
R1037	VRS-CY1JF561J	R 560	1/16W Metal Oxide	AA	C859	VCKYPA1HB391K	R 390p 50V Ceramic		AA
R1041	VRS-CY1JF103J	R 10k	1/16W Metal Oxide	AA	C866	VCEAGA2EW106M	R 10 250V Electrolytic		AC
R1042	VRS-CY1JF562J	R 5.6k	1/16W Metal Oxide	AA					
R1043	VRS-CY1JF101J	R 100	1/16W Metal Oxide	AA					
R1044	VRS-CY1JF472J	R 4.7k	1/16W Metal Oxide	AA					
R1045	VRS-CY1JF103J	R 10k	1/16W Metal Oxide	AA					
R1046	VRS-CY1JF102J	R 1k	1/16W Metal Oxide	AA					
R1048	VRS-CY1JF153J	R 15k	1/16W Metal Oxide	AA					
R1049	VRS-CY1JF822J	R 8.2k	1/16W Metal Oxide	AA					
R1050	VRS-CY1JF103J	R 10k	1/16W Metal Oxide	AA					
R1051	VRS-CY1JF561J	R 560	1/16W Metal Oxide	AA					

Ref. No.	Part No.	★	Description	Code
DUNTK9486WET4 CRT UNIT (Continude)				
RESISTORS				
R851	VRD-RA2BE101J	R 100	1/8W Carbon	AB
R852	VRD-RA2BE101J	R 100	1/8W Carbon	AB
R853	VRD-RA2BE101J	R 100	1/8W Carbon	AB
R855	VRD-RM2HD272J	R 2.7k	1/2W Carbon	AA
R861	VRD-RM2HD272J	R 2.7k	1/2W Carbon	AA
R867	VRD-RM2HD272J	R 2.7k	1/2W Carbon	AA
R875	VRD-RA2BE560J	R 56	1/8W Carbon	AA
R876	VRD-RA2BE560J	R 56	1/8W Carbon	AA
R877	VRD-RA2BE560J	R 56	1/8W Carbon	AA

MISCELLANEOUS PARTS				
P851	QPLGN0361CEZZ	R	Plug, 3 Pin	AB
P852	QPLGN0561CEZZ	R	Plug, 5 Pin	AB
△ SC851	QSOCV0919CEZZ	R	Socket, 9 Pin	AH
TP851	QTIPM0083CEZZ	R	Tip	AB
TP852	QTIPM0083CEZZ	R	Tip	AB
TP853	QTIPM0083CEZZ	R	Tip	AB
	PRDAR0248PEFW	R	Heat Sink, for IC851	AF

MISCELLANEOUS PARTS				
CN402	QCNW-0024PEZZ		Connecting Cord	
CN752	QCNW-0022PEZZ		Connecting Cord	
CN753	QCNW-0023PEZZ		Connecting Cord	
CN851	QCNW-2187PEZZ	R	Connecting Cord	AG
CN852	QCNW-0020PEZZ		Connecting Cord	
CN1101	QCNW-0025PEZZ	R	Connecting Cord	AF
CN3302	QCNW-2222PEZZ	R	Connecting Cord	AK
CN3306	QCNW-2224PEZZ	R	Connecting Cord	AH

SUPPLIED ACCESSORIES				
	QACCZ3008PEZZ	R	AC Cord	AN
	QCNW-2193PEZZ	R	Connecting Cord	AK
	RRMCG1399PESA		Infrared R-C	
	TINS-0096KJZZ		Instruction Book	

PACKING PARTS (NOT REPLACEMENT ITEM)				
	SPAKC0090KJZZ	-	Packing Case	—
	SPAKP0008KJZZ	-	Wrapping Paper	—
	SPAKX0061KJZZ	-	Packing Add.	—
	SPAKX0062KJZZ	-	Packing Add.	—
	SSAKA0230CEZZ	-	Polyethylene Bag	—

CABINET PARTS				
1	CCABA0060WEA0		Front Cabinet Ass'y	
1-1	<i>Not Available</i>	-	Front Cabinet	—
			(Not Replacement Item)	
1-2	HBDGB3119CESA	R	Badge, SHARP	AG
1-3	HDECQ0025KJSA		LED Cover, R/C	
1-4	JBTN-0032KJSA		Power Button	
1-5	JBTN-0033KJSA		Control Button	
2	CCABB0039WEA0		Rear Cabinet Ass'y	
2-1	<i>Not Available</i>	-	Rear Cabinet	—
			(Not Replacement Item)	
2-2	HiNDP0014KJZZ		A/V Indicator	

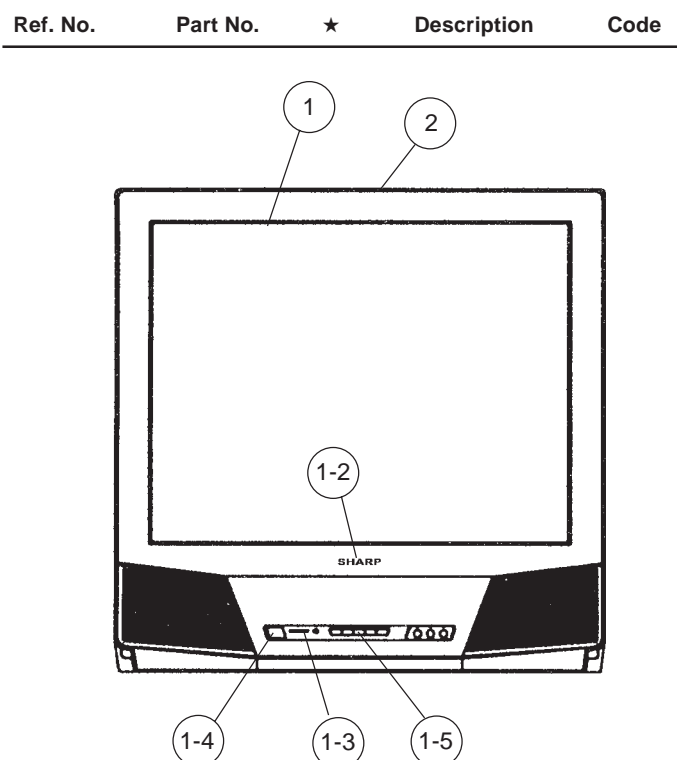

SHARP

COPYRIGHT © 1998 BY SHARP CORPORATION

ALL RIGHTS RESERVED.

No part of this publication may be reproduced, stored in a retrieval system, or transmitted in any form or by any means, electronic, mechanical, photocopying, recording, or otherwise, without prior written permission of the publisher.