

4

3

2

1

THIS DRAWING IS UNPUBLISHED.

RELEASED FOR PUBLICATION

AUG ,2006.

© COPYRIGHT BY TYCO ELECTRONICS CORPORATION.

ALL RIGHTS RESERVED.

LOC DW DIST

REVISIONS

P	LTR	DESCRIPTION	DATE	DWN	APVD
		SEE SHEET 1.			

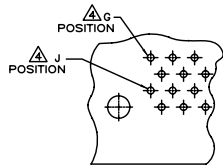

FOR 50, AND 130 POSITIONS ONLY

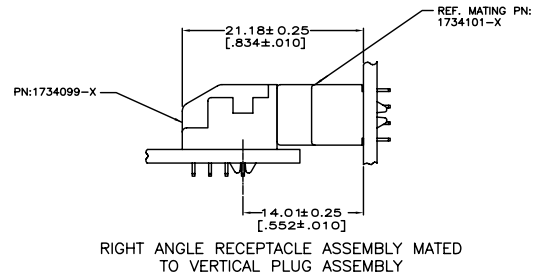
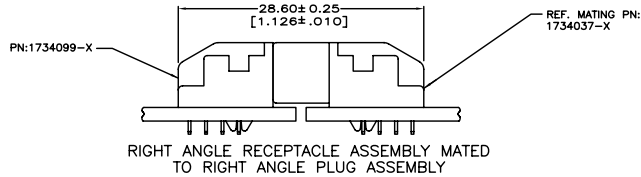
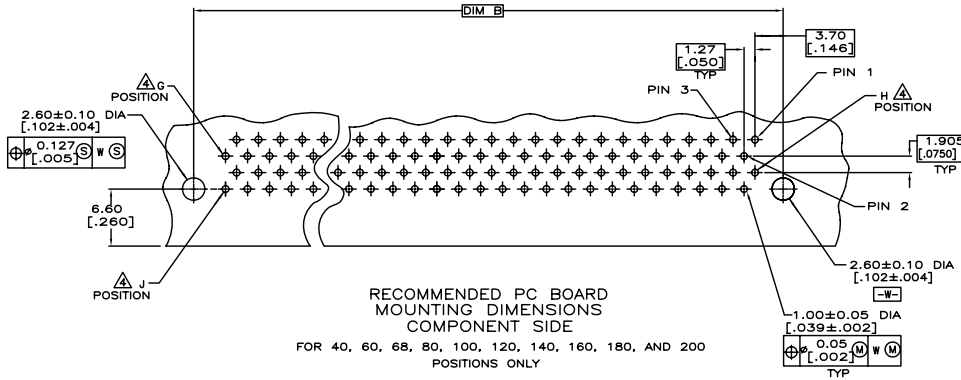

THIS DRAWING IS A CONTROLLED DOCUMENT.		DWN		Tyco Electronics Corporation Taipei, Taiwan	
DIMENSIONS: MM		TOLERANCES UNLESS OTHERWISE SPECIFIED:		NAME	
		0 PLC ± - 1 PLC ± - 2 PLC ± - 3 PLC ± - 4 PLC ± - ANGLES ± -		PRODUCT SPEC APPLICATION SPEC WEIGHT	
MATERIAL		FINISH		SIZE A3 CAGE CODE 00779 DRAWING NO G=1734099	
CUSTOMER DRAWING				RESTRICTED TO SCALE - SHEET 2 OF 4 REV D	

4

3

2

1

THIS DRAWING IS UNPUBLISHED.

RELEASED FOR PUBLICATION

AUG, 2006.

© COPYRIGHT BY TYCO ELECTRONICS CORPORATION. ALL RIGHTS RESERVED.

LOC DW

DIST

REVISIONS

P	LTR	DESCRIPTION	DATE	DWN	APVD
		SEE SHEET 1.			

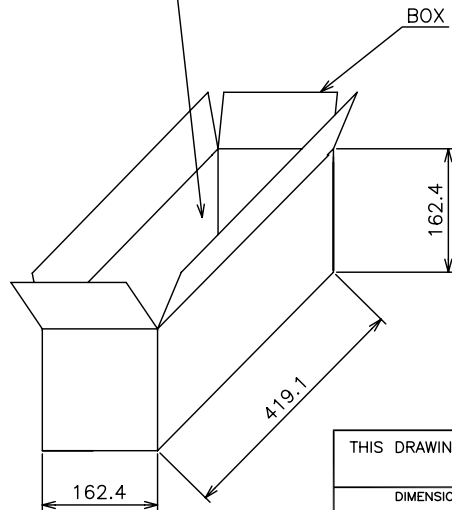
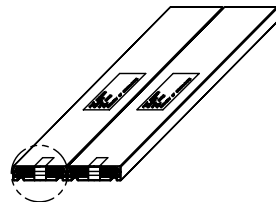
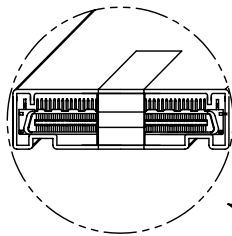
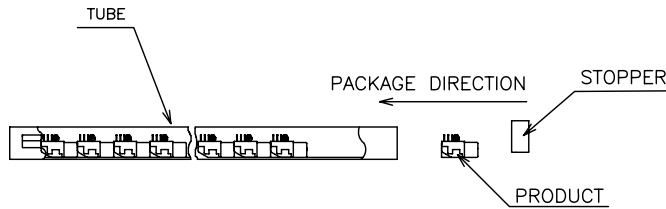

POS.	Q'TY/TUBE	TUBE/BOX	Q'TY/BOX	N/W (KG)	G/W (KG)	PART NUMBER
100	21	16	336	2.60	3.44	5-1734099-0
						3-1734099-0
						1-1734099-0
80	21	16	336	2.15	3.00	4-1734099-8
						2-1734099-8
						1734099-8

THIS DRAWING IS A CONTROLLED DOCUMENT.

Tyco Electronics Tyco Electronics Corporation
Taipei, Taiwan

PLUG ASSEMBLY, R/A,
BTB, CHAMP .050, SERIES I

SIZE: A3 CAGE CODE: 00779 G=1734099

CUSTOMER DRAWING SCALE: SHEET 3 OF 4 REV D

DIMENSIONS: MM	TOLERANCES UNLESS OTHERWISE SPECIFIED:	0 PLC ± -	1 PLC ± -	2 PLC ± -	3 PLC ± -	4 PLC ± -	ANGLES ± -
MATERIAL	FINISH	-					

4

3

2

1

THIS DRAWING IS UNPUBLISHED.

RELEASED FOR PUBLICATION

AUG, 2006.

© COPYRIGHT BY TYCO ELECTRONICS CORPORATION.

ALL RIGHTS RESERVED.

LOC DW DIST

REVISIONS

P	LTR	DESCRIPTION	DATE	DWN	APVD
		SEE SHEET 1.			

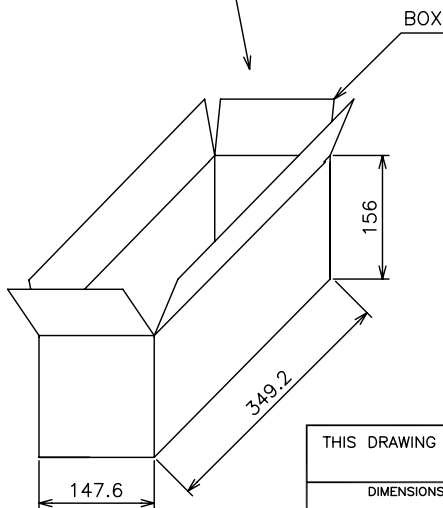
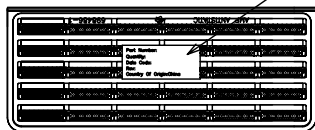
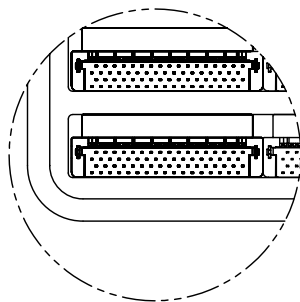
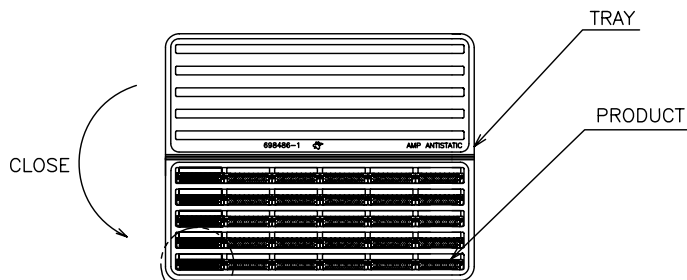

POS.	Q'TY/ TRAY	TRAY/ BOX	Q'TY/ BOX	N/W (KG)	G/W (KG)	PART NUMBER
200	10	10	100	1.40KG	2.35KG	5-1734099-8 3-1734099-8 1-1734099-8
160	10	10	100	1.18KG	2.13KG	5-1734099-6 3-1734099-6 1-1734099-6
140	15	10	150	1.59KG	2.46KG	5-1734099-4 3-1734099-4 1-1734099-4
120	15	10	150	1.20KG	2.15KG	5-1734099-2 3-1734099-2 1-1734099-2
68	30	10	300	1.69KG	2.64KG	4-1734099-7 2-1734099-7 1734099-7
60	30	10	300	1.53KG	2.48KG	4-1734099-6 2-1734099-6 1734099-6
50	35	10	350	1.58KG	2.56KG	4-1734099-5 2-1734099-5 1734099-5
40	45	10	450	1.71KG	2.66KG	4-1734099-4 2-1734099-4 1734099-4

THIS DRAWING IS A CONTROLLED DOCUMENT.

DIMENSIONS: MM	TOLERANCES UNLESS OTHERWISE SPECIFIED:	DWN	Tyco Electronics Corporation Taipei, Taiwan		
	0 PLC ± -	CHK	NAME		
	1 PLC ± -	APVD	PLUG ASSEMBLY, R/A, BTB, CHAMP .050, SERIES I		
	2 PLC ± -	PRODUCT SPEC	SIZE	CAGE CODE	DRAWING NO
	3 PLC ± -	APPLICATION SPEC	A3	00779	G=1734099
	4 PLC ± -	WEIGHT	RESTRICTED TO		
	ANGLES ± -	CUSTOMER DRAWING	SCALE	SHEET	REV
MATERIAL	FINISH			4 OF 4	D