

REVISONS		DATE	BY	APPV
L3	REVISED PER ECO-11-004587	11MAR11	RK	HMR

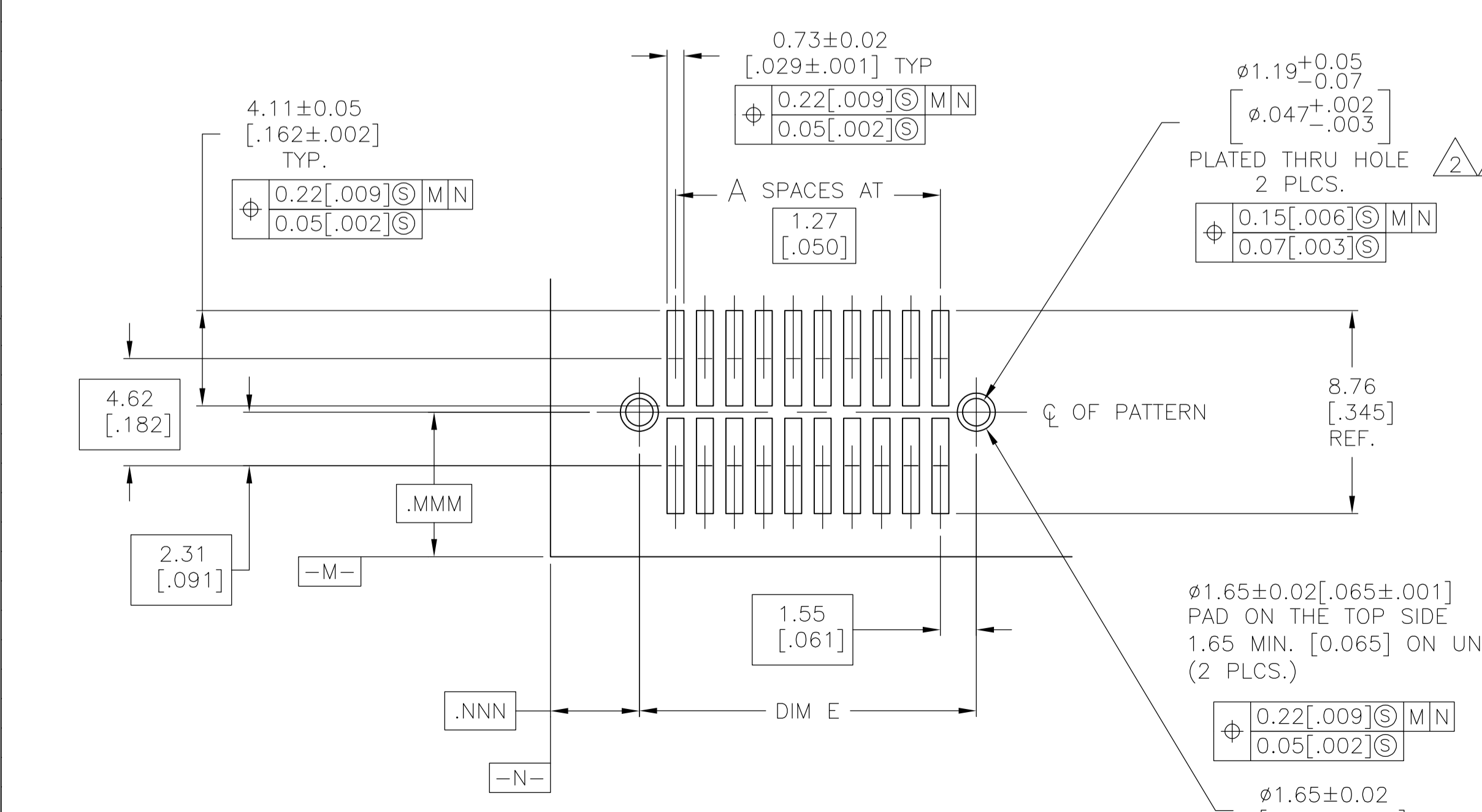
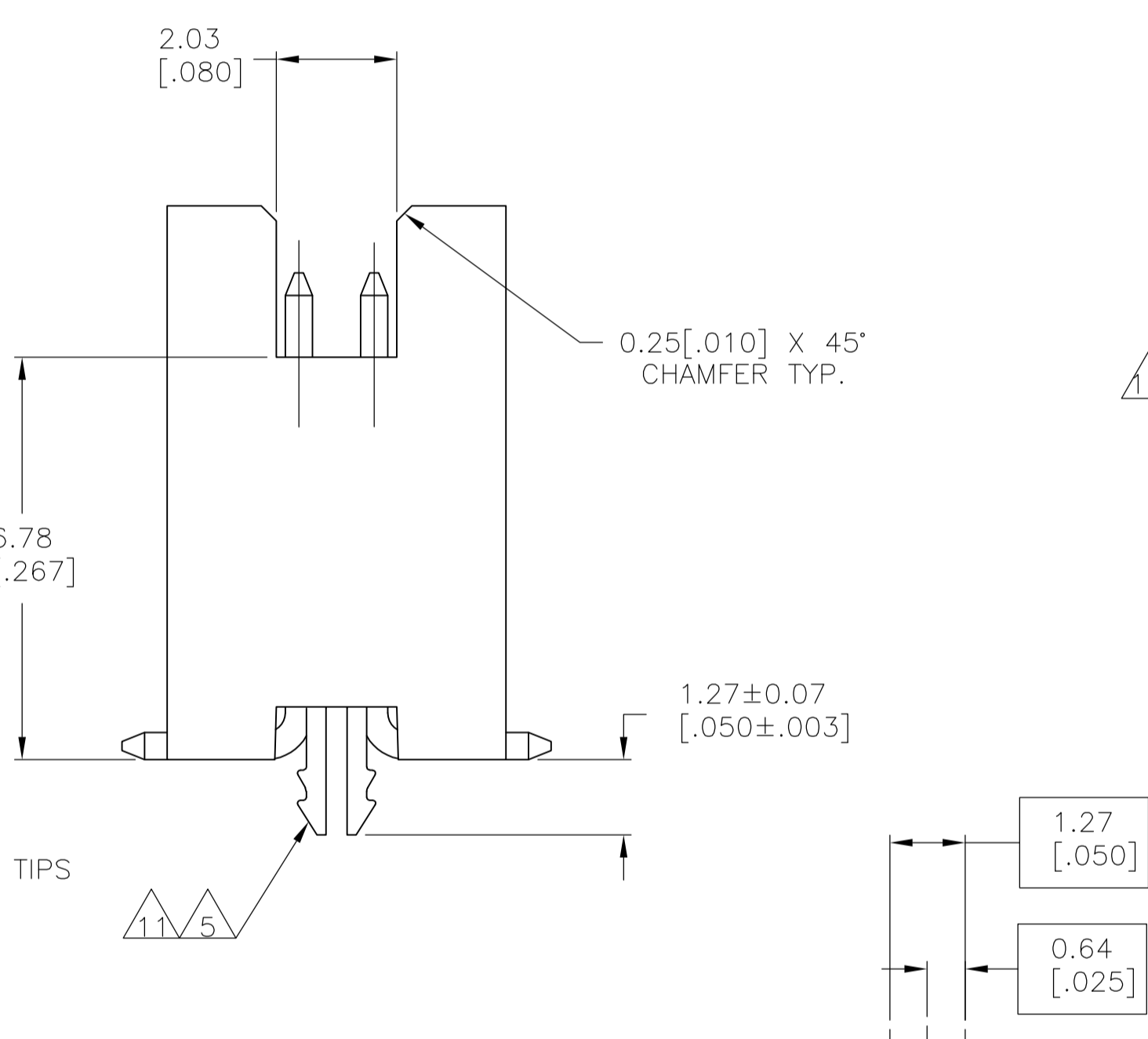
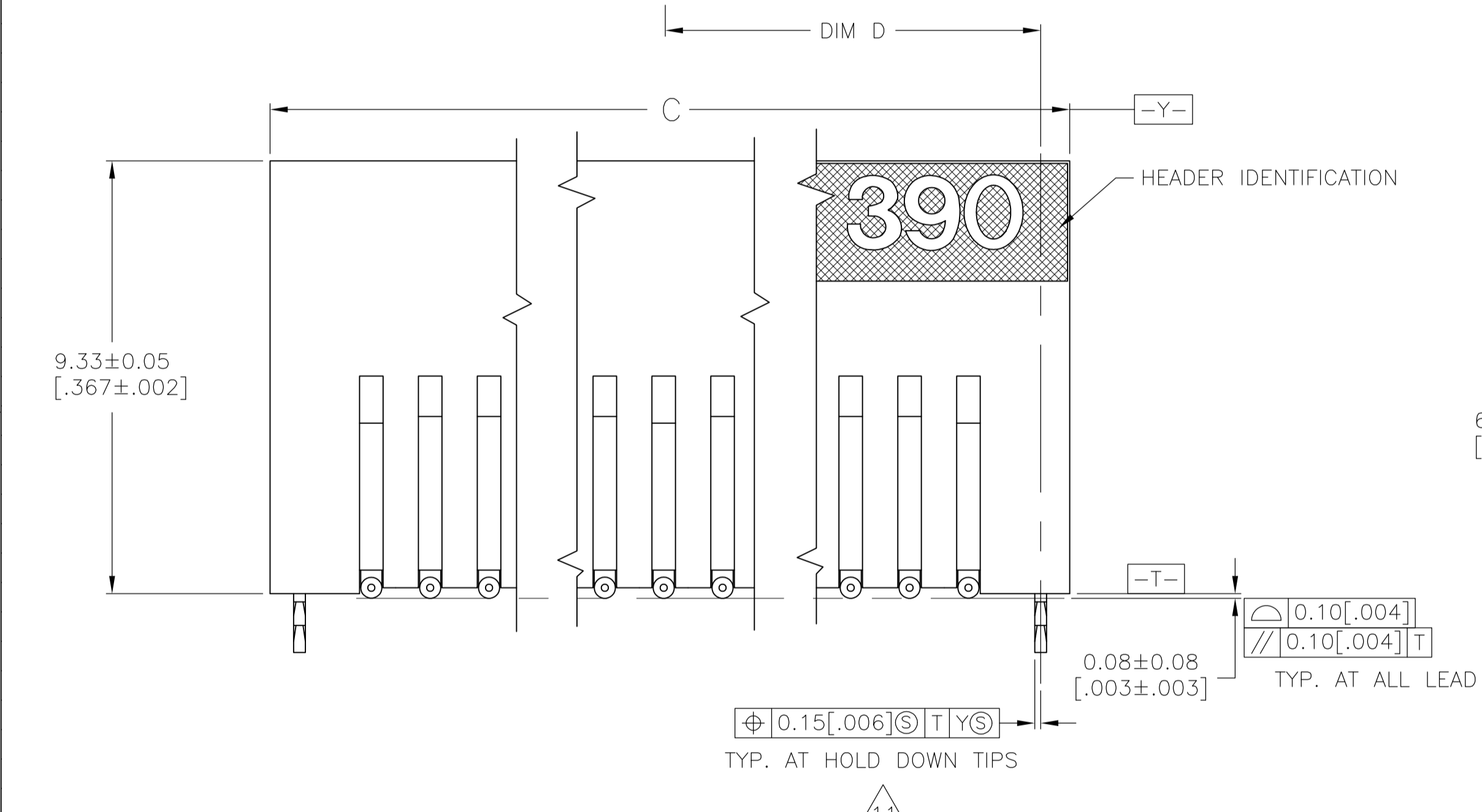
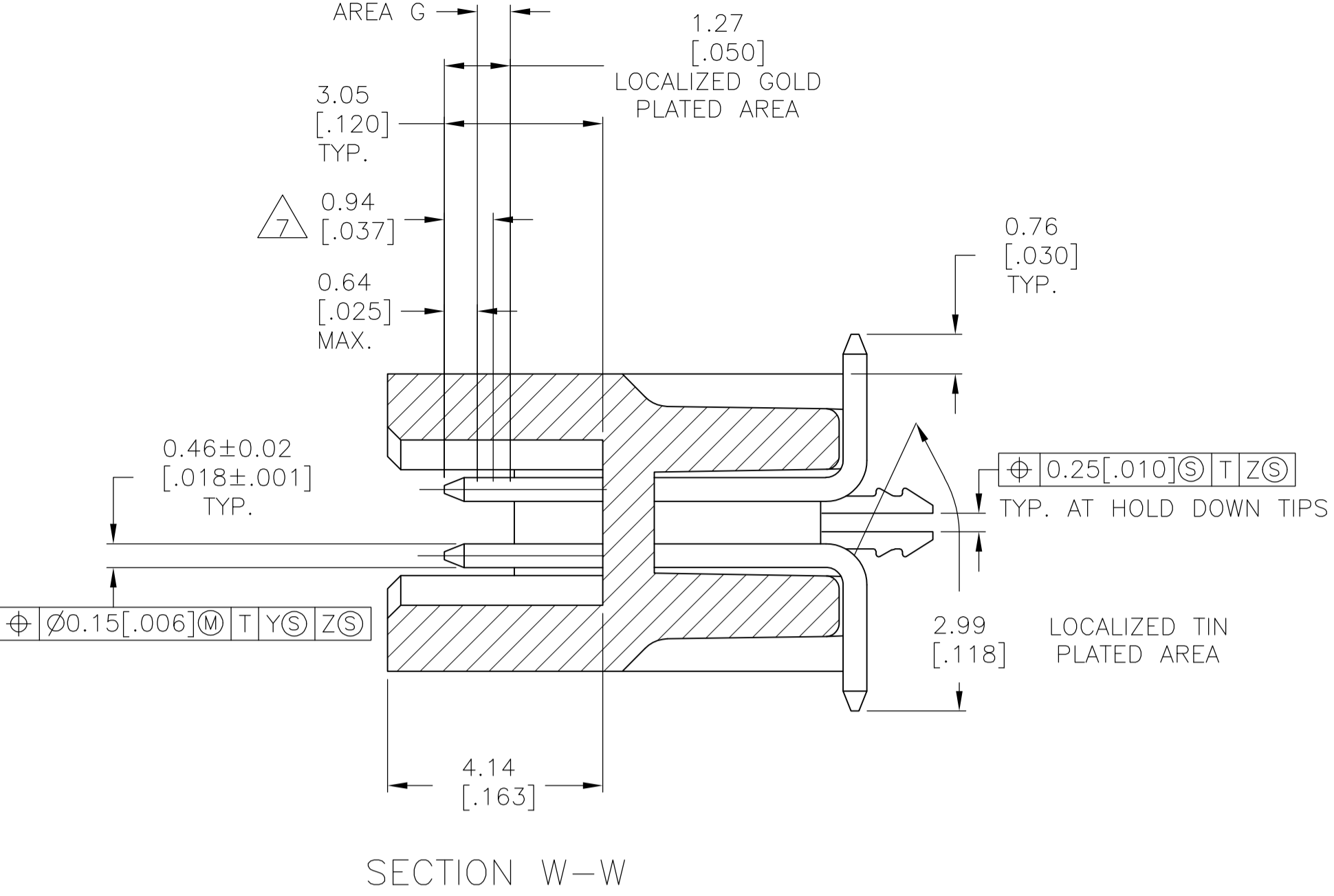
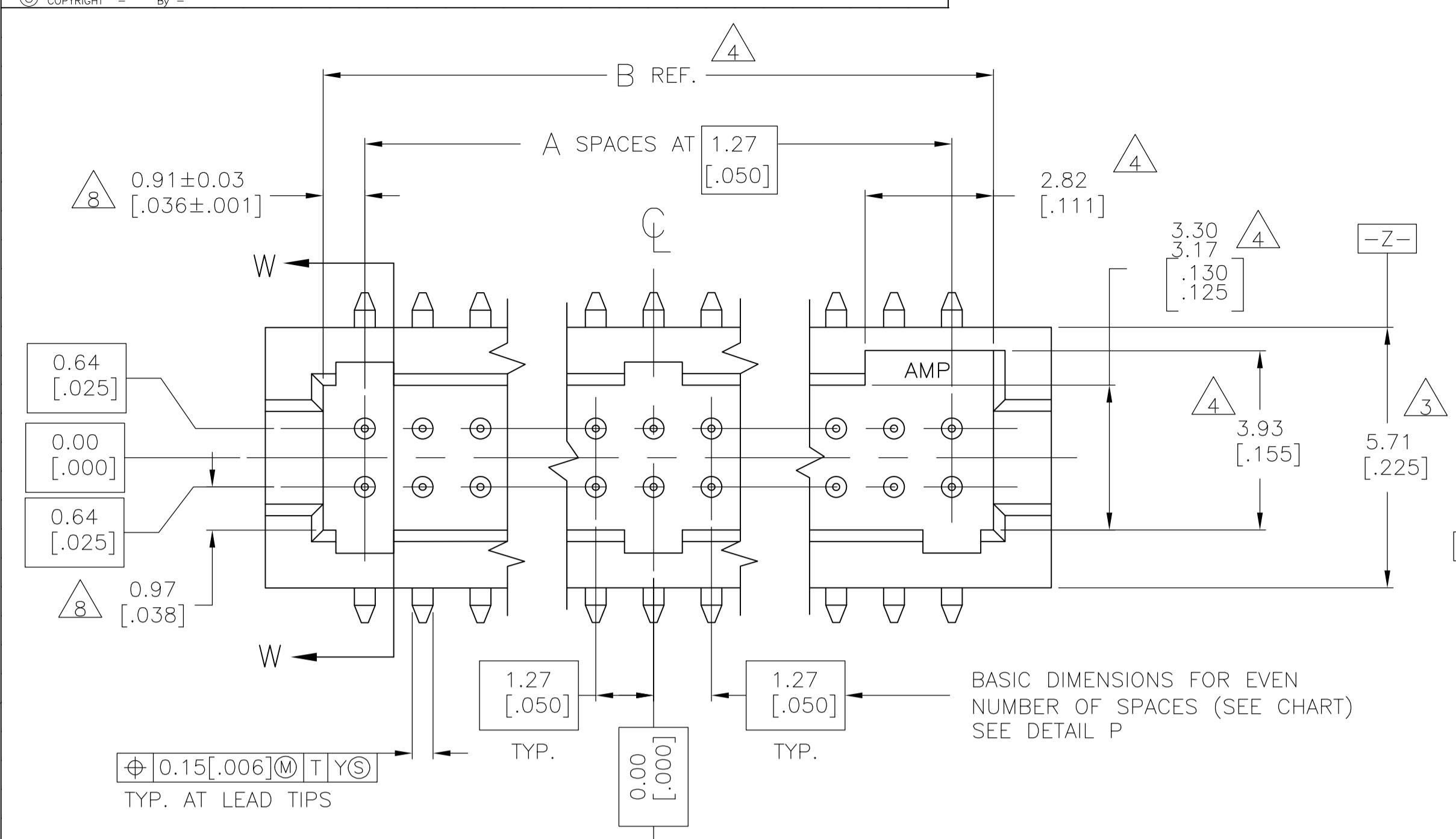

- 1 0.00076(.000030) GOLD AT POINT OF MEASUREMENT, 0.00051(.000020) MIN AT THE END POINTS OF AREA G, (LOCALIZED GOLD PLATE AREA), 0.0038(.000150) TIN-LEAD ON LOCALIZED TIN PLATED AREA, ALL OVER 0.0013(.000050) NICKEL
- 2 USE 1.32±0.02(.0520±.0010) DRILLED HOLE (#55 DRILL). FINISH TO BE TIN-LEAD OVER 0.02 [.001] MIN COPPER.
- 3 DIMENSION APPLIES AT BASE OF SHROUD.
- 4 THE NOTED DIMENSIONS APPLY AT THE MATING FACE OF THE HOUSING.
- 5 0.0038 [.000150] TIN-LEAD ON HOLD DOWN, ALL OVER 0.0013 [.000050] NICKEL.
- 6 IF PLANNING TO USE MORE THAN ONE MATING PAIR OF CONNECTORS TO INTERCONNECT 2 BOARDS, PLEASE REFER TO SPACING PARAGRAPH IN APPLICATION SPEC, #114-7010
- 7 POINT OF MEASUREMENT
- 8 DIMENSIONS NOTED APPLY FROM THE BASIC DIMENSION LINE (NOT THE CIRCUIT CAVITY CENTER LINE) TO THE SURFACE INDICATED.
- 9 0.00076 (.000030) GOLD AT POINT OF MEASUREMENT, 0.00051(.000020) MIN AT THE END POINTS OF AREA G (LOCALIZED GOLD PLATE AREA), 0.0038(.000150) TIN ON LOCALIZED TIN PLATED AREA, ALL OVER 0.0013(.000050) NICKEL.
- 10 USE 1.32±0.02(.0520±.0010) DRILLED HOLE (#55 DRILL) FINISH TO BE TIN OVER 0.02(.001) MIN COPPER.
- 11 0.0038 (.000150) TIN ON HOLDDOWN, ALL OVER 0.0013 (.000050) NICKEL
- 12 ROHS 2002/95/EC COMPLIANT.
- 13 OBSOLETE PARTS: OBSOLETE CIS STREAMLINING PER D.RENAUD/D.SINISI

FINISH	E	D	C	B	A	NUMBER OF POSITIONS	PART NUMBER	
								9
OBSOLETE	9	11	65.33 [2.572]	32.66 [1.286]	66.59 [2.622]	64.05 [2.522]	49 100 6-104693-0	
	9	11	58.98 [2.322]	29.48 [1.161]	60.24 [2.372]	57.70 [2.272]	44 90 5-104693-9	
	9	11	52.63 [2.072]	26.31 [1.036]	53.89 [2.122]	51.35 [2.022]	39 80 5-104693-8	
	9	11	46.28 [1.822]	23.13 [0.911]	47.54 [1.872]	45.00 [1.772]	34 70 5-104693-7	
	9	11	39.93 [1.572]	19.96 [0.786]	41.19 [1.622]	38.65 [1.522]	29 60 5-104693-6	
	9	11	33.58 [1.322]	16.78 [0.661]	34.84 [1.372]	32.30 [1.272]	24 50 5-104693-5	
	9	11	27.23 [1.072]	13.61 [0.536]	28.49 [1.122]	25.95 [1.022]	19 40 5-104693-4	
	9	11	20.88 [0.822]	10.43 [0.411]	22.14 [0.872]	19.60 [0.772]	14 30 5-104693-3	
	9	11	14.53 [0.572]	7.26 [0.286]	15.79 [0.622]	13.25 [0.522]	9 20 5-104693-2	
	9	11	8.18 [0.322]	4.08 [0.161]	9.44 [0.372]	6.90 [0.272]	4 10 5-104693-1	
	OBSOLETE	1	5	65.33 [2.572]	32.66 [1.286]	66.59 [2.622]	64.05 [2.522]	49 100 1-104693-0
		1	5	58.98 [2.322]	29.48 [1.161]	60.24 [2.372]	57.70 [2.272]	44 90 1-04693-9
		1	5	52.63 [2.072]	26.31 [1.036]	53.89 [2.122]	51.35 [2.022]	39 80 104693-8
1		5	46.28 [1.822]	23.13 [0.911]	47.54 [1.872]	45.00 [1.772]	34 70 104693-7	
1		5	39.93 [1.572]	19.96 [0.786]	41.19 [1.622]	38.65 [1.522]	29 60 104693-6	
1		5	33.58 [1.322]	16.78 [0.661]	34.84 [1.372]	32.30 [1.272]	24 50 104693-5	
1		5	27.23 [1.072]	13.61 [0.536]	28.49 [1.122]	25.95 [1.022]	19 40 104693-4	
1		5	20.88 [0.822]	10.43 [0.411]	22.14 [0.872]	19.60 [0.772]	14 30 104693-3	
1		5	14.53 [0.572]	7.26 [0.286]	15.79 [0.622]	13.25 [0.522]	9 20 104693-2	
1		5	8.18 [0.322]	4.08 [0.161]	9.44 [0.372]	6.90 [0.272]	4 10 104693-1	
FINISH		E	D	C	B	A	NUMBER OF POSITIONS	PART NUMBER

RECOMMENDED BOARD LAYOUT SCALE 5:1

THIS DRAWING IS A CONTROLLED DOCUMENT.

DIMENSIONS: mm (INCHES)

TOLERANCES UNLESS OTHERWISE SPECIFIED:

0 PL	±	-
1 PL	±	-
2 PL	±	0.13 [.005]
3 PL	±	-
4 PL	±	-
ANGLES	±	-

MATERIAL: INDUSTRY SPEC. ALUMINUM BRASS. HOLD-DOWN: COPPER ALLOY.

FINISH: SEE TABLE.

THIS DRAWING IS A CONTROLLED DOCUMENT. KATE HELM 01AUG08 8/12/91. D. GORENC 8/12/91. D. GORENC 8/12/91. NAME: PRODUCT SPEC. 108-1332. APPLICATION SPEC. 114-7010. WEIGHT: -. SIZE: A1. CASE CODE: DRAWING NO. 104693. RESTRICTED TO: CUSTOMER DRAWING. SCALE: 10:1. SHEET: 1 OF 1. REV: L3.

STE TE Connectivity

HEADER ASSEMBLY, SURFACE MOUNT, AMPMODU 50/50 GRID (9.90 [.390] MATED HEIGHT)