

Verpackt in Gurtverpackung
 Tape on Reel Packaging
 Verpackungseinheit: 420 Stück
 Packaging unit: 420 pcs

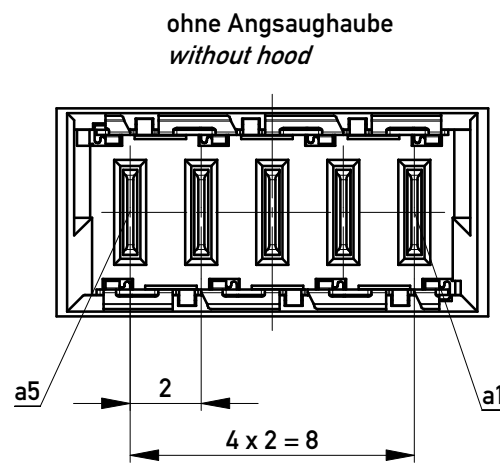

Abspulrichtung - Reel off Direction

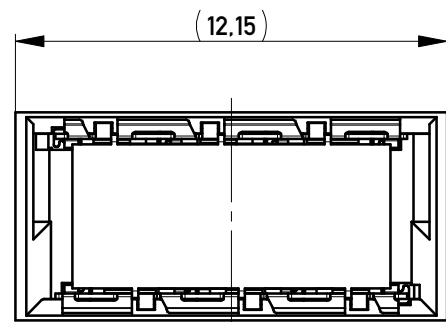
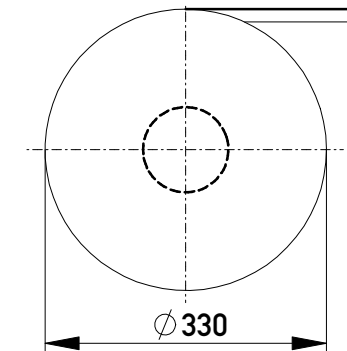
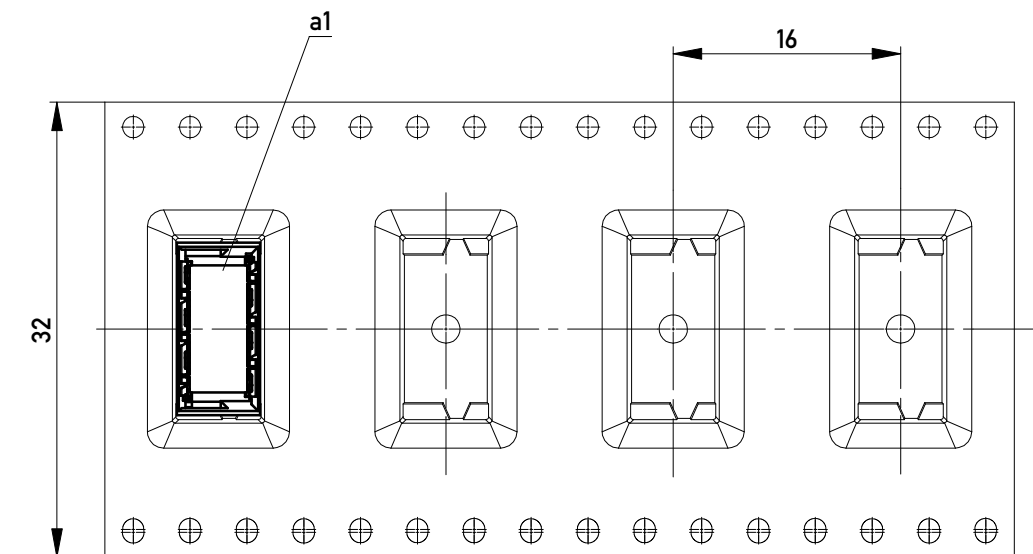

Leiterplatten-Layout Vorschlag / PCB-Layout Proposal

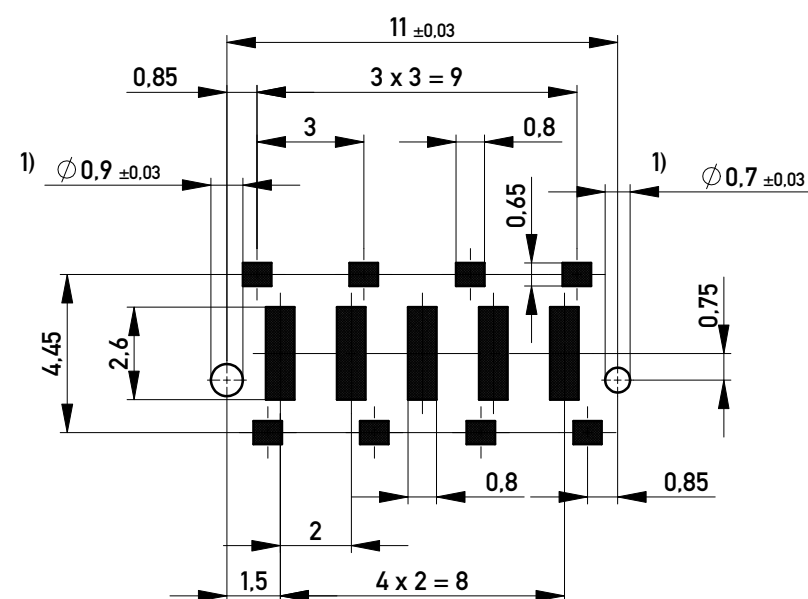

1) Durchmesser des Bohrers / Drill tool

Anforderungsstufe 1
 Performance Level 1

Kontaktbereich vergoldet
 Mating Area gold plating

Anschlussbereich verzinkt 4-6 µm
 Terminal Area 4-6 µm tin plating

Koplanarität der Anschlüsse ≤ 0,1 mm
 Coplanarity Area of Termination ≤ 0,1 mm

Copyright by ERNI GmbH Proprietary notice pursuant to ISO 16016 to be observed.	Information:	Tolerances	 All Dimensions in mm	Scale	5:1
	All rights reserved. Only for Information. To ensure that this is the latest version of this drawing, please contact one of the ERNI companies before using.	Subject to modification without prior notice. Drawing will not be updated.	 www.ERNI.com	Designation Messerleiste SMD, Powerm. 1mm Male Con. SMD, Powerm. 1mm	100103020001
k	05.02.2013	Date		Class	MSPEED